

SYN4375 Dual-Band Wi-Fi™ + Bluetooth™ Combo SoC with RSDB

Product Brief



The Synaptics SYN4375 system on chip (SoC) combines a dual-band (2.4 GHz, 5 GHz) Wi-Fi 2x2 MAC/baseband/radio with integrated Bluetooth 5.3 to reduce the space, cost, power, complexity, and time to market of wirelessly enabled IoT devices.

Features

- Supports Wi-Fi 2.4/5 GHz with best CMOS RF, including integrated power amplifiers (PAs) and low-noise amplifiers (LNAs) (external PA and LNA optional) with highest transmit (Tx) power level and receive (Rx) sensitivity; capable of 1024 QAM over 10 meters.
- IEEE 802.11ax compliant with legacy support for 802.11a/b/g/n/ac.
- Supports real-time simultaneous dual-band (RSDB) operation at 2.4 and 5 GHz.
- 20/40/80 MHz channels for the main (Main) 2x2 Wi-Fi core (1024-QAM modulation), and 20/40 MHz channels for the auxiliary (Aux) 2x2 Wi-Fi core (256-QAM modulation).
- 2x2 Wi-Fi antenna array.
- Zero wait dynamic frequency selection (DFS); background channel availability check (CAC) scan for immediate switch to candidate DFS channel.
- Supports three antennas with one dedicated to Bluetooth and two to Wi-Fi.
- Integrated Bluetooth 5.3 with support for Bluetooth Low Energy (BLE).
- Internal Bluetooth PA supports two modes: Normal Output Power Mode (14 dBm) and High Output Power Mode (20 dBm).
- Synaptics Smart Co-Ex for best-in-class coexistence of Wi-Fi and Bluetooth radios in the 2.4 GHz band.

Benefits

- High integration reduces footprint, cost, power, complexity, and time to market.
- Operates in 2.4 GHz and 5GHz bands simultaneously with up to 1200 Mbps throughput.
- RSDB allows the 2.4 GHz and 5 GHz radios to connect and stream multimedia content at the same time for optimum performance and more robust connectivity.
- Allows multiple concurrent Bluetooth connections and audio streams.
- Advanced Wi-Fi/Bluetooth radio co-existence capability for high quality of service (QoS) and robust connections.
- Secure.
- Seamless interoperability across multiple heterogeneous wireless networks.

Applications

- Multimedia streaming for the smart home
- Automotive in-cabin entertainment
- Personal area networks
- Security
- Smart factories/Industry 4.0

SYN4375 Dual-Band Wi-Fi™ + Bluetooth™ Combo SoC with RSDB

Product Brief

System Block Diagram

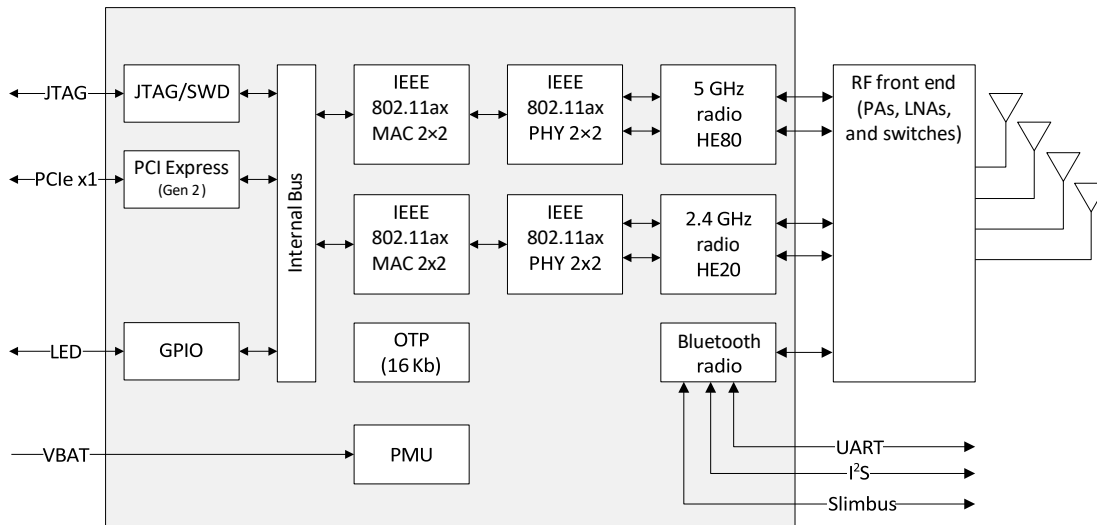

Trademarks

Synaptics and the Synaptics logo are trademarks or registered trademarks of Synaptics Incorporated or its affiliates in the United States and/or other countries. All other marks are the property of their respective owners.

Notice

Use of the materials may require a license of intellectual property from a third party or from Synaptics. This document conveys no express or implied licenses to any intellectual property rights belonging to Synaptics or any other party. Synaptics may, from time to time and at its sole option, update the information contained in this document without notice.

INFORMATION CONTAINED IN THIS DOCUMENT IS PROVIDED "AS-IS," WITH NO EXPRESS OR IMPLIED WARRANTIES, INCLUDING ANY IMPLIED WARRANTIES OF MERCHANTABILITY AND FITNESS FOR A PARTICULAR PURPOSE, AND ANY WARRANTIES OF NON-INFRINGEMENT OF ANY INTELLECTUAL PROPERTY RIGHTS. IN NO EVENT SHALL SYNAPTICS BE LIABLE FOR ANY DIRECT, INDIRECT, INCIDENTAL, SPECIAL, PUNITIVE, OR CONSEQUENTIAL DAMAGES ARISING OUT OF OR IN CONNECTION WITH THE USE OF THE INFORMATION CONTAINED IN THIS DOCUMENT, HOWEVER CAUSED AND BASED ON ANY THEORY OF LIABILITY, WHETHER IN AN ACTION OF CONTRACT, NEGLIGENCE OR OTHER TORTIOUS ACTION, AND EVEN IF SYNAPTICS WAS ADVISED OF THE POSSIBILITY OF SUCH DAMAGE. IF A TRIBUNAL OF COMPETENT JURISDICTION DOES NOT PERMIT THE DISCLAIMER OF DIRECT DAMAGES OR ANY OTHER DAMAGES, SYNAPTICS' TOTAL CUMULATIVE LIABILITY TO ANY PARTY SHALL NOT EXCEED ONE HUNDRED U.S. DOLLARS.