

# SYN4382 "Triple Combo 2" Wi-Fi™, Bluetooth™, IEEE 802.15.4 (Zigbee/Thread) SoC

## Product Brief

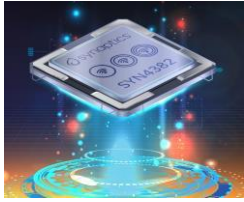

The SYN4382 "Triple Combo 2" integrates Wi-Fi 6/6E, Bluetooth 5.3, and IEEE 802.15.4 radios on a single state-of-the-art system-on-chip (SoC) to reduce the space, cost, power, complexity, and time to market of wirelessly enabled IoT devices. With applications ranging from multimedia streaming for the smart home to automotive entertainment, security, and the smart factory, the SYN4382 is Matter compliant

for secure, seamless interoperability in a heterogeneous, multi-platform wireless environment.

The Wi-Fi radio is IEEE 802.11ax compliant with legacy support for 802.11a/b/g/n, has a 2 x 2 antenna arrangement for a throughput of up to 1200 Mbps, and features real-time simultaneous dual-band (RSDB) capability to allow the 2.4 GHz and either the 5 or 6 GHz radios to connect and stream multimedia content at the same time for optimum performance and more robust connectivity. The Bluetooth 5.3 radio features LE Audio for multiple concurrent Bluetooth audio streaming connections, as well as Bluetooth Channel Sounding for accurate positioning. Built-in support for the Thread networking protocol allows devices using the SYN4382 to connect to a smart home's secure, low-power mesh network while acting as a Thread Router node including advanced mesh networking and security features.

Other features include on-chip power amplifiers (PAs) and low-noise amplifiers (LNAs), with support for external PAs and LNAs and Synaptics Smart Co-Ex technology for best-in-class coexistence of Wi-Fi and Bluetooth radios in the 2.4 GHz band.

## Features

- Supports Wi-Fi 2.4/5/6/6E with best CMOS RF, including integrated PAs and LNAs (external PA and LNA optional) with highest transmit (Tx) power level and receive (Rx) sensitivity.
- Supports real-time simultaneous dual-band (RSDB) operation with 2.4 GHz radio and either 5 or 6 GHz radio.
- 2x2 antenna array.
- Integrated Bluetooth 5.3 with support for Bluetooth Low Energy (BLE) and BLE Channel Sounding (HADM: high-accuracy distance measurement).
- LE Audio support.
- IEEE 802.15.4 physical layer (PHY) for Zigbee and Thread support.
- Application-layer support for Matter-compliant security and interoperability.
- Synaptics Smart Co-Ex for best-in-class coexistence of Wi-Fi and Bluetooth radios in the 2.4 GHz band.

## Benefits

- High integration reduces footprint, cost, power, complexity, and time to market.
- Operates in 2.4 GHz and 5 or 6 GHz bands simultaneously with up to 1200 Mbps throughput.
- Allows multiple concurrent Bluetooth connections and audio streams.
- Enables highly accurate positioning.
- Advanced Wi-Fi/Bluetooth radio co-existence capability for high quality of service (QoS) and robust connections.

- Secure
- Seamless interoperability across multiple heterogeneous wireless networks.

## Applications

- Multimedia streaming for the smart home
- Automotive in-cabin entertainment
- Position tracking
- Personal area networks
- Security
- Smart factories/Industry 4.0

### System Block Diagram

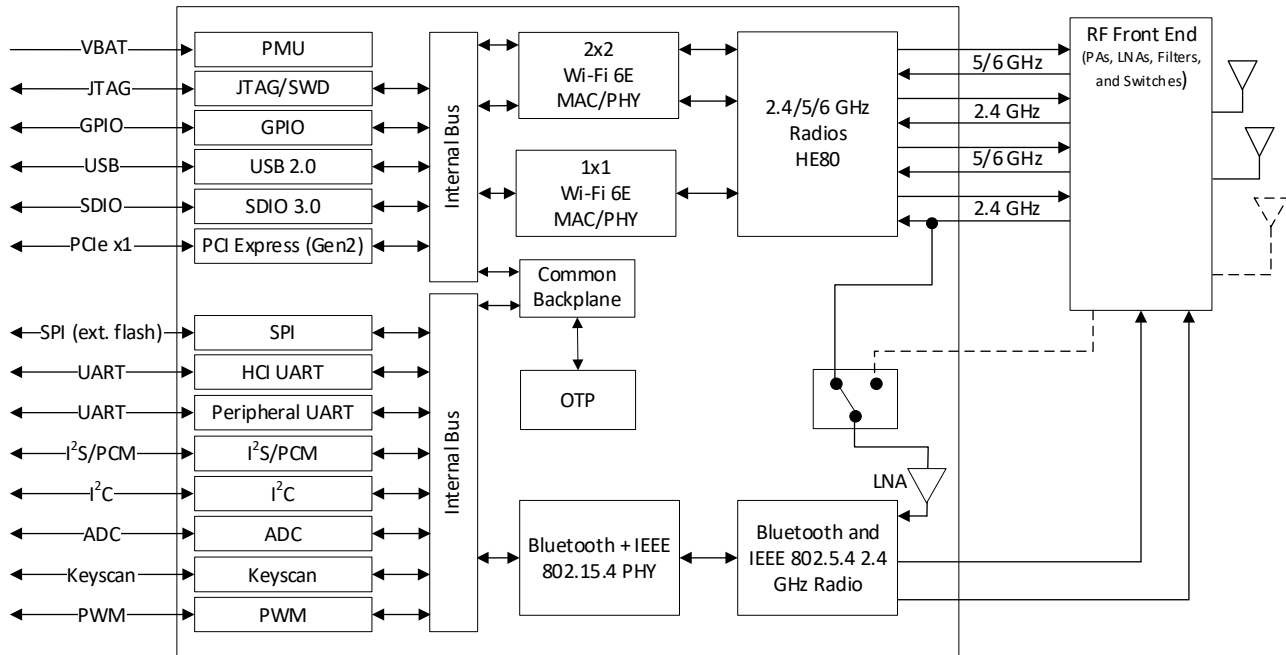

### Trademarks

Synaptics and the Synaptics logo are trademarks or registered trademarks of Synaptics Incorporated or its affiliates in the United States and/or other countries. All other marks are the property of their respective owners.

### Notice

Use of the materials may require a license of intellectual property from a third party or from Synaptics. This document conveys no express or implied licenses to any intellectual property rights belonging to Synaptics or any other party. Synaptics may, from time to time and at its sole option, update the information contained in this document without notice.

INFORMATION CONTAINED IN THIS DOCUMENT IS PROVIDED "AS-IS," WITH NO EXPRESS OR IMPLIED WARRANTIES, INCLUDING ANY IMPLIED WARRANTIES OF MERCHANTABILITY AND FITNESS FOR A PARTICULAR PURPOSE, AND ANY WARRANTIES OF NON-INFRINGEMENT OF ANY INTELLECTUAL PROPERTY RIGHTS. IN NO EVENT SHALL SYNAPTICS BE LIABLE FOR ANY DIRECT, INDIRECT, INCIDENTAL, SPECIAL, PUNITIVE, OR CONSEQUENTIAL DAMAGES ARISING OUT OF OR IN CONNECTION WITH THE USE OF THE INFORMATION CONTAINED IN THIS DOCUMENT, HOWEVER CAUSED AND BASED ON ANY THEORY OF LIABILITY, WHETHER IN AN ACTION OF CONTRACT, NEGLIGENCE OR OTHER TORTIOUS ACTION, AND EVEN IF SYNAPTICS WAS ADVISED OF THE POSSIBILITY OF SUCH DAMAGE. IF A TRIBUNAL OF COMPETENT JURISDICTION DOES NOT PERMIT THE DISCLAIMER OF DIRECT DAMAGES OR ANY OTHER DAMAGES, SYNAPTICS' TOTAL CUMULATIVE LIABILITY TO ANY PARTY SHALL NOT EXCEED ONE HUNDRED U.S. DOLLARS.