



Application Note

# Astra™ Machina Foundation Series MIPI CSI Camera Module Hardware Connection

Abstract: This application note details the MIPI CSI Camera Module connection for core modules containing the SL1680 SoC

# Contents

1.	Overview .....	5
1.1.	Scope .....	5
1.2.	Hardware Accessory Items Needed for 5MP Camera Support .....	6
1.2.1.	Setting a Document's Properties .....	6
1.3.	Hardware Accessory Items Needed for 8MP Camera Support .....	8
1.4.	Hardware Accessory Items Needed for External MIPI–CSI Adapter .....	10
1.5.	Connection Block Diagram .....	11
1.6.	Making the Connection for the External MIPI CSI Camera Module .....	12
1.7.	Basic Information of MIPI CSI Camera Adapter .....	14
2.	References .....	15
3.	Revision History .....	16

## List of Figures

Figure 1. Overview of Astra Machina Foundation Series.....	5
Figure 2. OV5647 5MP Camera Module interface to SL1680 .....	6
Figure 3. SL1680 MIPI-CSII connector pinout.....	7
Figure 4. IMX415 8MP Camera Module interface to SL1680 .....	8
Figure 5. SL1680 MIPI-CSIO connector pinout.....	9
Figure 6. Connection block diagram for MIPI CSI Camera Module .....	11
Figure 7. Connector Actuator Status & FFC cable side (Type 1).....	12
Figure 8. Connector Actuator Status & FFC cable side (Type 2) .....	12
Figure 9. Connector connection with IMX258 module adapter.....	13
Figure 10. Complete connection with converter & IMX258 adapter .....	13

## List of Tables

Table 1. SL1680 MIPI-CSII Connector Pin Definition .....	7
Table 2. SL1680 MIPI-CSIO Connector Pin Definition.....	9

# 1. Overview

The Astra™ Machina Foundation Series offers evaluation-ready kits that facilitate quick and straightforward prototyping with the Synaptics SL-Series of embedded Linux® and Android™ processors. Featuring a modular design, these kits include interchangeable core compute modules, a standard I/O board and variety of daughter cards for connectivity, debugging, and various I/O configurations.

## 1.1. Scope

This document offers a MIPI CSI Camera Module connection diagram specifically for core modules containing the SL1680 SoC. It is designed to connect popular Image Sensor Modules using the Synaptics CSI Camera adapter board and connector converter.

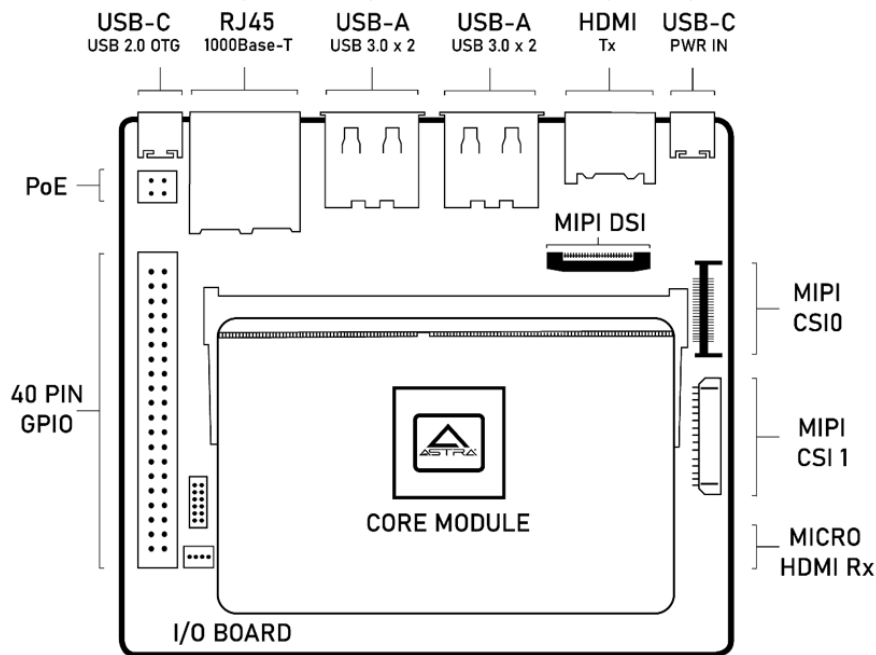

Figure 1. Overview of Astra Machina Foundation Series

## 1.2. Hardware Accessory Items Needed for 5MP Camera Support

### 1.2.1. Setting a Document's Properties

- [a] Synaptics Astra Machina SL1680 evaluation board.
- [b] OV5647 5MP HiLetgo Camera Module with 1.00mm 15-pin FFC/FPC cable.
- [c] OV5647 5MP HiLetgo Camera Module details can be found in link:  
<http://www.hiletgo.com/ProductDetail/1949787.html>

- Camera Module Brand: HiLetgo
- Model Name: OV5647 5MP Camera Module
- Sensor: OV5647 (5MPixel)
- Video Capture Resolution: up to 1080p30
- Camcorder Type: Video Camera
- MIPI Channels: 2-CH
- Connector: 15-pin 1.00mm FFC/FPC cable
- Control Interface: I2C

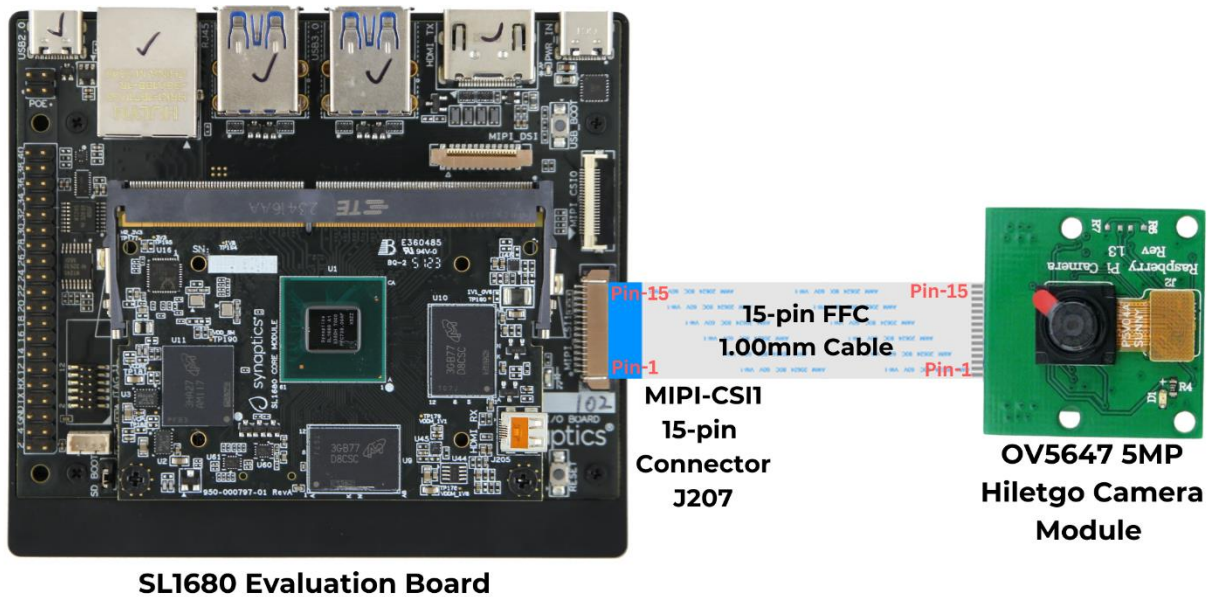

Figure 2. OV5647 5MP Camera Module interface to SL1680

Table 1. SL1680 MIPI-CSI1 Connector Pin Definition

Pin #	Name	Description
1	GND	Ground
2	CAM_DO_N	MIPI Data Lane 0 Negative
3	CAM_DO_P	MIPI Data Lane 0 Positive
4	GND	Ground
5	CAM_D1_N	MIPI Data Lane 1 Negative
6	CAM_D1_P	MIPI Data Lane 1 Positive
7	GND	Ground
8	CAM_CK_N	MIPI Clock Lane Negative
9	CAM_CK_P	MIPI Clock Lane Positive
10	GND	Ground
11	CAM_IO0	Power Enable
12	CAM_IO1	LED Indicator
13	CAM_SCL	I2C SCL
14	CAM_SDA	I2C SDA
15	CAM_3V3	3.3V Power Input

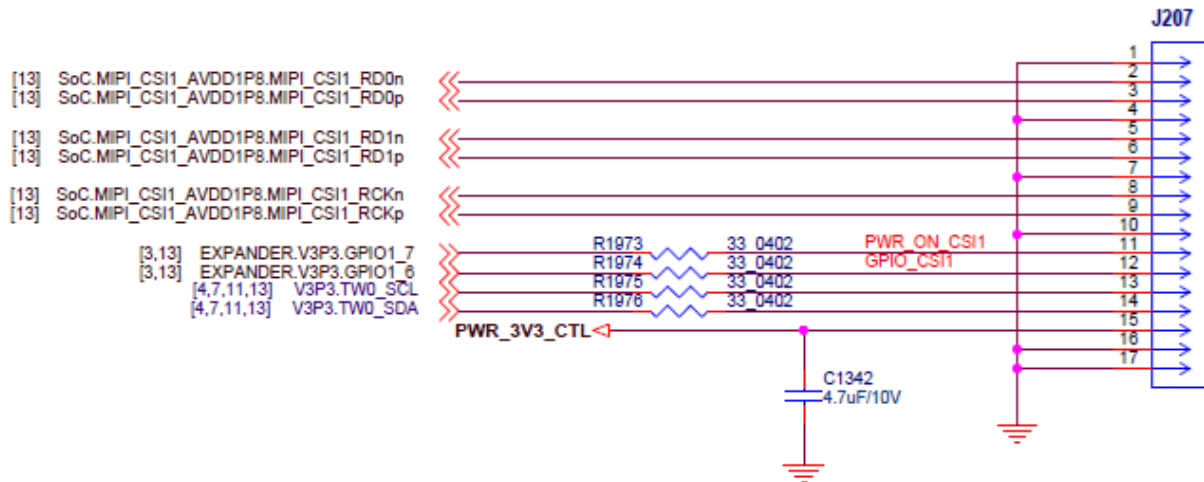

Figure 3. SL1680 MIPI-CSI1 connector pinout

### 1.3. Hardware Accessory Items Needed for 8MP Camera Support

- [a] Synaptics Astra Machina SL1680 evaluation board.
- [b] IMX415 8MP Waveshare Camera Module with 0.5mm 22-pin FFC/FPC cable.
- [c] IMX415 8MP Waveshare Camera Module details can be found in link: <https://www.waveshare.com/imx415-98-ir-cut-camera.htm>

- Camera Module Brand: Waveshare
- Model Name: IMX415-98 IR-CUT Camera
- Sensor: IMX415 (8MPixel)
- Video Capture Resolution: up to 3840x2160 @ 90 FPS
- Camcorder Type: Video Camera
- MIPI Channels: 4-CH or 2-CH
- Connector: 22-pin 0.5mm FFC/FPC cable
- Control Interface: I2C

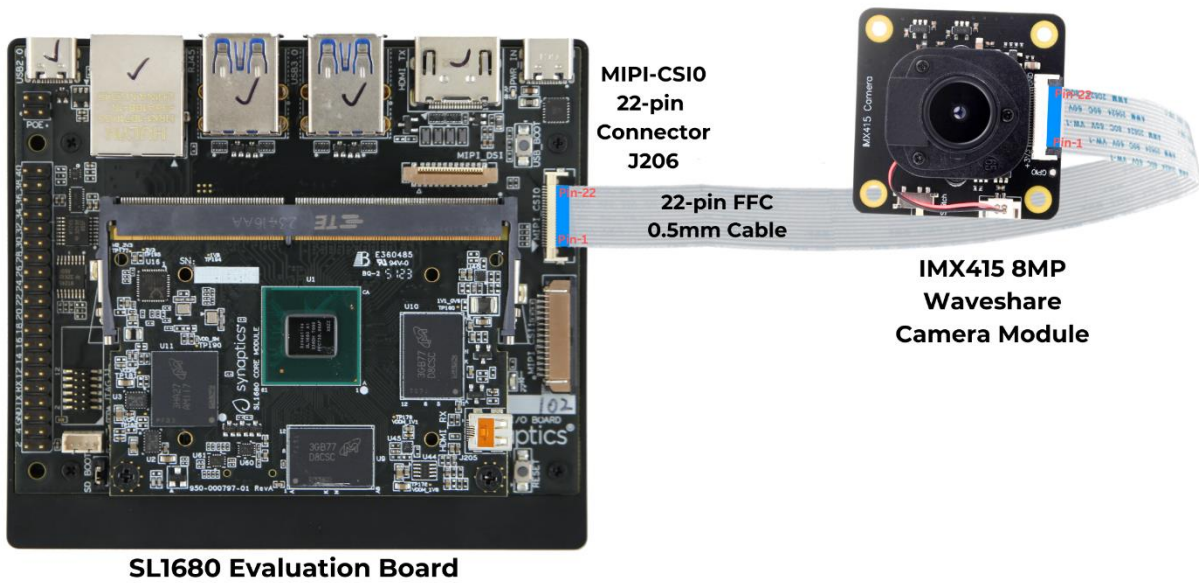

Figure 4. IMX415 8MP Camera Module interface to SL1680



Table 2. SL1680 MIPI-CSIO Connector Pin Definition

Pin #	Name	Description
22	GND	Power Ground
21	CAM_DO_N	Pixel Data Lane 0 Negative
20	CAM_DO_P	Pixel Data Lane 0 Positive
19	GND	Power Ground
18	CAM_D1_N	Pixel Data Lane 1 Negative
17	CAM_D1_P	Pixel Data Lane 1 Positive
16	GND	Power Ground
15	CAM_CK_N	Pixel Clock Output Form Sensor Negative
14	CAM_CK_P	Pixel Clock Output Form Sensor Positive
13	GND	Power Ground
12	CAM_D2_N	Pixel Data Lane 2 Negative
11	CAM_D2_P	Pixel Data Lane 2 Positive
10	GND	Power Ground
9	CAM_D3_N	Pixel Data Lane 3 Negative
8	CAM_D3_P	Pixel Data Lane 3 Positive
7	GND	Power Ground
6	POWER-EN	Power Enable
5	LED-EN	LED Enable/XCLK
4	GND	Power Ground
3	SCL	SCCB Serial Interface Clock Input
2	SDA	SCCB Serial Interface Data I/O
1	VCC	3.3V Power Supply

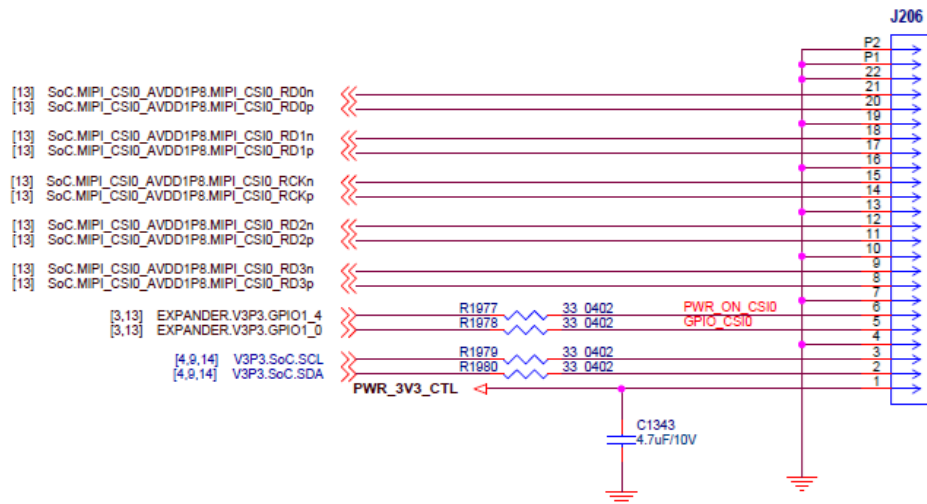

Figure 5. SL1680 MIPI-CSIO connector pinout

## 1.4. Hardware Accessory Items Needed for External MIPI–CSI Adapter

- [a] Synaptics Astra Machina Foundation Series.
- [b] Synaptics CSI Camera Adapter Board for Sony IMX258 Module (PN: RD–CSI–IMX–258–R1) or for IMX415 Module (PN: RD–CSI–IMX–415–R1).
- [c] Synaptics FFC type to QTH type Connector Converter Board (PN: 730–C01089–01) for Astra Machina fits.
- [d] 50Mm length of 22pin/0.5mm pitch FFC cable.
- [e] Standard USB type A to Micro B cable.
- [f] The auxiliary 5V power supply can be provided by a standard mobile USB charger or a device port sourced by a host, such as a PC.

## 1.5. Connection Block Diagram

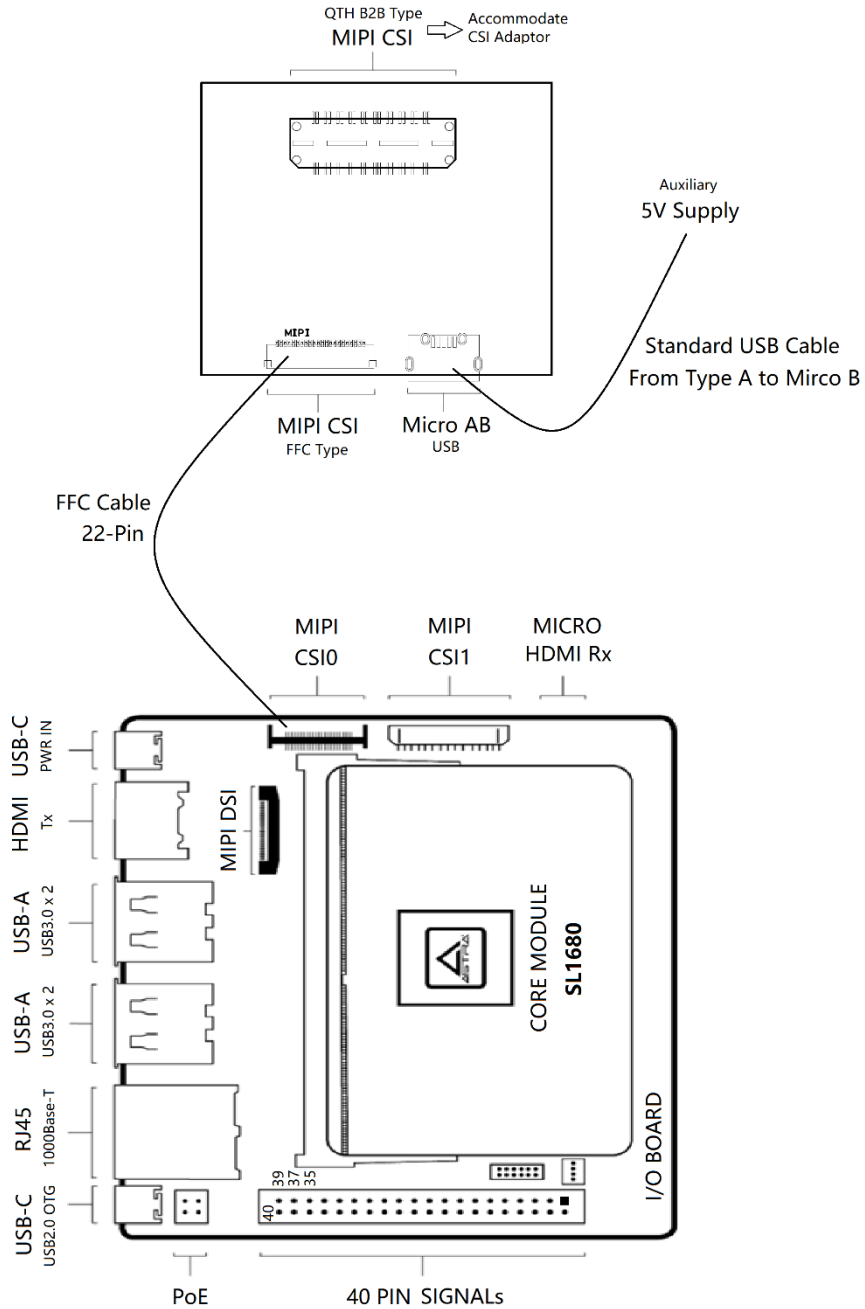

Figure 6. Connection block diagram for MIPI CSI Camera Module

## 1.6. Making the Connection for the External MIPI CSI Camera Module

- [a] Obtain the SL1680 core module that is equipped with the Astra I/O board.
- [b] Connect a 51mm FFC cable between the MIPI CSIO connector on the Astra I/O board and the FFC connector on the connector converter board as illustrated in **Error! Reference source not found.**. Ensure the actuator of the FFC connector on both the I/O and converter boards is open before inserting the cable. The stiffener film should face upwards, as depicted in Figure 7 and Figure 8.

Additionally, the Astra I/O board uses two types of FFC connectors:

- Type 1 features an edge-rotate actuator
- Type 2 features a pull-push actuator

Refer to Figure 7 or Figure 8 to connect the standard USB-A to Micro B cable with Micro AB connector of connector converter board and USB 5V power supply, as shown in **Error! Reference source not found.**

- [c] Connect CSI Camera adapter board with B2B QTH type connector of connector converter board. Note that the D-shaped design ensures seamless alignment and connection, as shown in Figure 9.

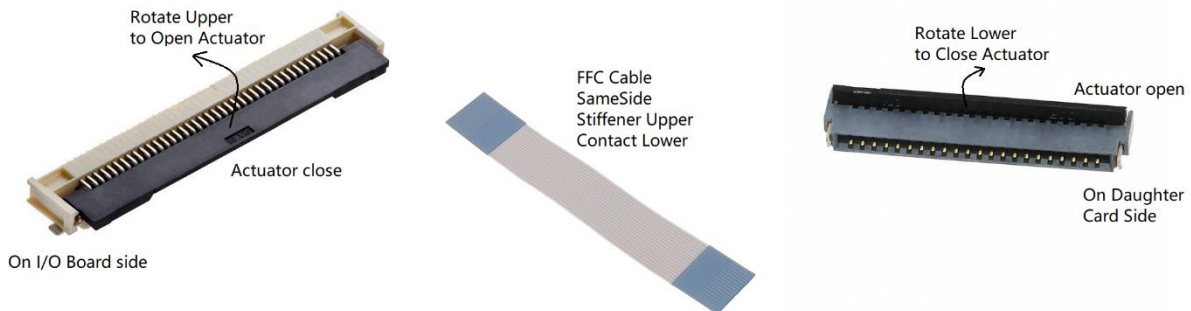

Figure 7. Connector Actuator Status & FFC cable side (Type 1)

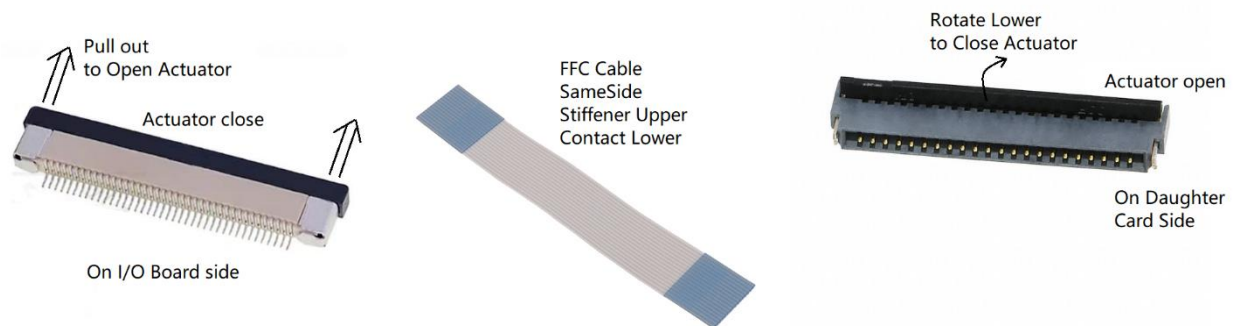

Figure 8. Connector Actuator Status & FFC cable side (Type 2)



Figure 9. Connector connection with IMX258 module adapter

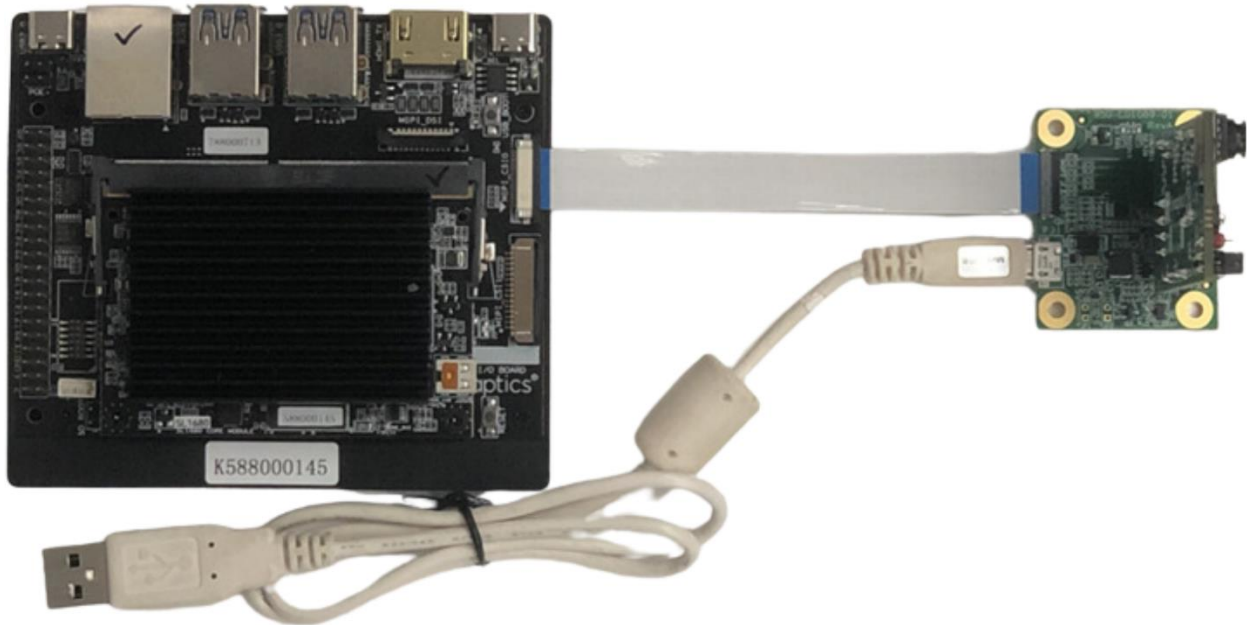

Figure 10. Complete connection with converter & IMX258 adapter

## 1.7. Basic Information of MIPI CSI Camera Adapter

The Synaptics-designed CSI Camera adapter board is compatible with the KLT-K7MF-IMX258 Camera module or the LI-IMX415-MIPI-M12.

The CSI x4 Lane supports resolutions up to 4K2K at 30fps or 1080p at 60fps.

## 2. References

---

- *Astra Machina Foundation Series Quick Start Guide* (PN: 511-001404-01)
- *Astra Machina SL1620 Developer Kit User Guide* (PN: 511-001407-01)
- *Astra Machina SL1640 Developer Kit User Guide* (PN: 511-001405-01)
- *Astra Machina SL1680 Developer Kit User Guide* (PN: 511-001403-01)
- *Synaptics CSI Camera Adapter Board for Sony IMX258 Module* (PN: RD-CSI-IMX-258-R1)
- *Synaptics CSI Camera Adapter Board for Sony IMX415 Module* (PN: RD-CSI-IMX-415-R1)
- *Synaptics FFC type to QTH type Connector Converter Board* (PN: 730-C01089-01)

### 3. Revision History

Revision	Description
A	Initial release.
B	Corrected cross-references in section 1.6 (Making the Connection).
C	Updated the following figures: <ul style="list-style-type: none"> <li>• Figure 6. Connection block diagram for MIPI CSI Camera Module</li> <li>• Figure 7. Connector Actuator Status &amp; FFC cable side (Type 1)</li> <li>• Figure 8. Connector Actuator Status &amp; FFC cable side (Type 2)</li> <li>• Figure 9. Connector connection with IMX258 module adapter</li> <li>• Figure 10. Complete connection with converter &amp; IMX258 adapter</li> </ul>
D	Updated to latest document template. No change to the technical content.



#### Copyright

Copyright © 2024–2025 Synaptics Incorporated. All Rights Reserved.

#### Trademarks

Synaptics, the Synaptics logo, Astra Machina, and SyNAP are trademarks or registered trademarks of Synaptics Incorporated in the United States and/or other countries.

Android is a trademark of Google LLC. Linux is the registered trademark of Linus Torvalds in the U.S. and other countries. All other trademarks are the properties of their respective owners.

#### Contact Us

Visit our website at [www.synaptics.com](http://www.synaptics.com) to locate the Synaptics office nearest you.

PN: 506-001522-01 Rev D

#### Notice

Use of the materials may require a license of intellectual property from a third party or from Synaptics. This document conveys no express or implied licenses to any intellectual property rights belonging to Synaptics or any other party. Synaptics may, from time to time and at its sole option, update the information contained in this document without notice.

INFORMATION CONTAINED IN THIS DOCUMENT IS PROVIDED "AS-IS," AND SYNAPTICS HEREBY DISCLAIMS ALL EXPRESS OR IMPLIED WARRANTIES, INCLUDING BUT NOT LIMITED TO ANY IMPLIED WARRANTIES OF MERCHANTABILITY AND FITNESS FOR A PARTICULAR PURPOSE, AND ANY WARRANTIES OF NON-INFRINGEMENT OF ANY INTELLECTUAL PROPERTY RIGHTS. IN NO EVENT SHALL SYNAPTICS BE LIABLE FOR ANY DIRECT, INDIRECT, INCIDENTAL, SPECIAL, PUNITIVE, OR CONSEQUENTIAL DAMAGES ARISING OUT OF OR IN CONNECTION WITH THE USE OF THE INFORMATION CONTAINED IN THIS DOCUMENT, HOWEVER CAUSED AND BASED ON ANY THEORY OF LIABILITY, WHETHER IN AN ACTION OF CONTRACT, NEGLIGENCE OR OTHER TORTIOUS ACTION, AND EVEN IF SYNAPTICS WAS ADVISED OF THE POSSIBILITY OF SUCH DAMAGE. IF A TRIBUNAL OF COMPETENT JURISDICTION DOES NOT PERMIT THE DISCLAIMER OF DIRECT DAMAGES OR ANY OTHER DAMAGES, SYNAPTICS' TOTAL CUMULATIVE LIABILITY TO ANY PARTY SHALL NOT EXCEED ONE HUNDRED U.S. DOLLARS.