

# certinia



## PSA Direct for Jira

Whether used by a technical team doing development as part of a project or by a project team working in an agile fashion, Atlassian Jira is often key to the success of services organizations. While Certinia PS Cloud is the system of record to manage the sales to delivery process holistically—including the financial view of a project—some resources spend all their time in Jira.

### One team serving the customer

The Certinia-to-Jira connector allows you to seamlessly connect Certinia PS Cloud and Jira to streamline your processes, ensuring that resources who use Jira can stay in sync with the Project and enter critical information such as time worked.

This connector allows resources to work in the tool best suited for their role, stay fully aligned around the work to be done, and enter critical data only once. The project manager and practice lead can see one comprehensive view of the project, allowing them to monitor health, manage change, and ensure billing and revenue forecasting remain current. As a result, your organization can more successfully deliver projects on time and increase customer satisfaction.

Timecard	
TCH-09-19-2019-000015	
Cost Rate Exchange Rate ⓘ	Billed
1.000000	<input type="checkbox"/>
Bill Rate Defaulted from Milestone ⓘ	Invoiced
<input type="checkbox"/>	<input type="checkbox"/>
▼ Hours and Notes	
Sunday Hours	Sund
0.00	
Monday Hours	Mon
8.00	[25]
Tuesday Hours	Tues
8.00	[25]
Wednesday Hours	Wed
8.00	[25]
Thursday Hours	Thur
4.00	[25]
Friday Hours	Frida
0.00	

# Jira to PS Cloud Connector Flow (Task level)

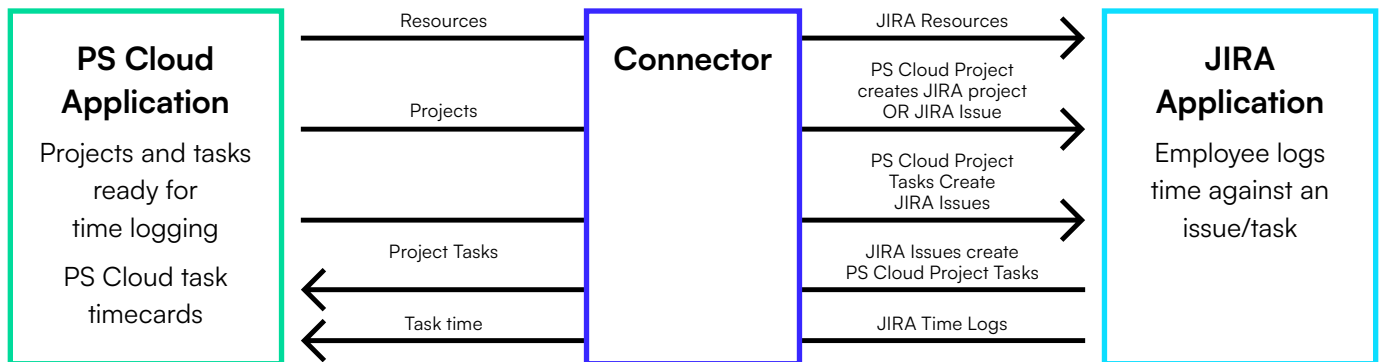

## Key benefits

- Comprehensive view of project health
- Shorter time to invoice
- Full synchronization between Certinia PS Cloud and Jira, no re-entry
- Resources enter critical data once

## Prerequisites

- Jira Cloud or Jira Server 8.0 or newer
- Salesforce with Certinia PS Cloud installed and configured - Jira users sending data to PS Cloud must have the appropriate PS Cloud licenses
- Certinia PS Cloud Fall 2020 version or later for task sync

## Capabilities

- Sync eligible Certinia PS Cloud resources to Jira users.
- Sync eligible Certinia PS Cloud projects to Jira projects, or issues of a predetermined type.
- Time entry in Jira is synced back to the task level or project level in PS Cloud
- Automatically update a Certinia PS Cloud project field when the related Jira issue is moved to a specific status.
- Sync Project Tasks to create Jira issues or Jira issues to create project tasks

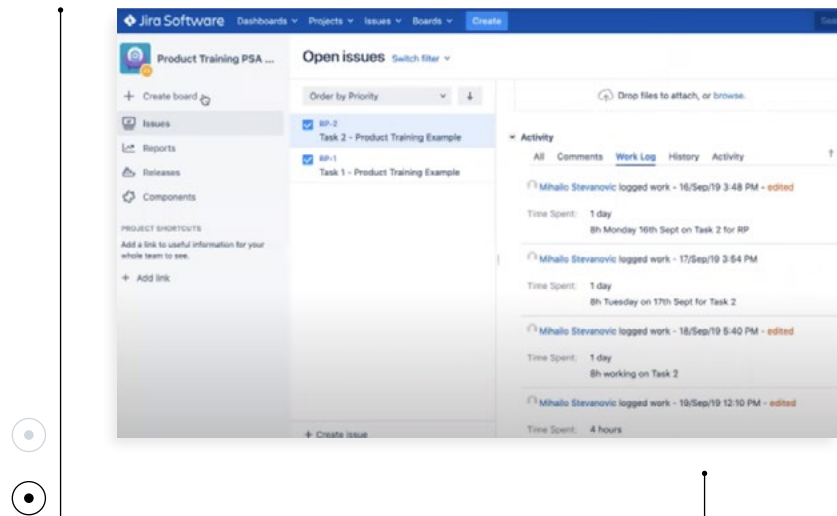

Certinia elevates business growth through a complete Services-as-a-Business solution spanning services delivery, finance, and customer success. Native to the leading cloud platform, Salesforce, Certinia enables organizations to run a connected business, deliver with intelligence, and achieve scalable agility. Founded in 2009 and headquartered in San Jose, Certinia is backed by Advent International, Salesforce Ventures, and Technology Crossover Ventures. For more information, visit [www.Certinia.com](http://www.Certinia.com).

**certinia**