

Installation Manual

Installation and Appliance Setup

INSTALLER: Leave this manual with party responsible for use and operation.
OWNER: Retain this manual for future reference.

NOTICE: DO NOT discard this manual!

HEAT & GLO

No one builds a better fire

Model:

ESC-42ST-IFT

GAS-FIRED

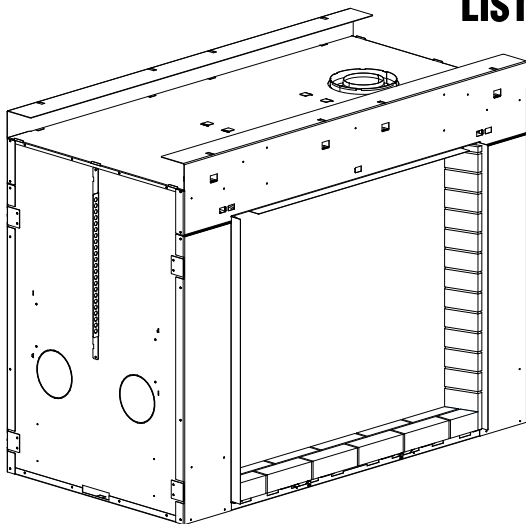

This appliance may be installed as an OEM installation in manufactured home (USA only) or mobile home and must be installed in accordance with the manufacturer's instructions and the *Manufactured Home Construction and Safety Standard, Title 24 CFR, Part 3280* in the United States, or the *Standard for Installation in Mobile Homes, CAN/CSA Z240 MH Series*, in Canada.

This appliance is only for use with the type(s) of gas indicated on the rating plate. This appliance is not convertible for use with other gases, unless a certified kit is used.

In the Commonwealth of Massachusetts installation must be performed by a licensed plumber or gas fitter. See Table of Contents for location of additional Commonwealth of Massachusetts requirements.

⚠ WARNING:
FIRE OR EXPLOSION HAZARD
Failure to follow safety warnings exactly could result in serious injury, death, or property damage.

- **DO NOT** store or use gasoline or other flammable vapors and liquids in the vicinity of this or any other appliance.
- **What to do if you smell gas**
 - **DO NOT** try to light any appliance.
 - **DO NOT** touch any electrical switch. **DO NOT** use any phone in your building.
 - Leave the building immediately.
 - Immediately call your gas supplier from a neighbor's phone. Follow the gas supplier's instructions.
 - If you cannot reach your gas supplier, call the fire department.
- Installation and service must be performed by a qualified installer, service agency, or the gas supplier.

! DANGER



HOT GLASS WILL CAUSE BURNS.

DO NOT TOUCH GLASS UNTIL COOLED.

NEVER ALLOW CHILDREN TO TOUCH GLASS.

A barrier designed to reduce the risk of burns from the hot viewing glass is provided with this appliance and must be installed for the protection of children and other at-risk individuals.

Pour demander un exemplaire en français de ce manuel d'installation, visitez www.heatnglo.com.

Safety Alert Key:

- **DANGER!** Indicates a hazardous situation which, if not avoided will result in death or serious injury.
- **WARNING!** Indicates a hazardous situation which, if not avoided could result in death or serious injury.
- **CAUTION!** Indicates a hazardous situation which, if not avoided, could result in minor or moderate injury.
- **NOTICE:** Used to address practices not related to personal injury.

Note: The term “recommend” or “recommended” does not indicate a requirement. It is a best practice suggested by Hearth & Home Technologies®.

Table of Contents

Installation Standard Work Checklist	3
--	---

1 Product Specific and Important Safety Information

A. Appliance Certification	4
B. Glass Specifications (Ceramic)	4
C. BTU Specifications	4
D. High Altitude Installations	4
E. Non-Combustible Materials Specification	4
F. Combustible Materials Specification	4
G. Electrical Codes	4
H. California	4
I. Requirements for the Commonwealth of Massachusetts	5

2 Getting Started

A. Design and Installation Considerations	6
B. Good Faith Wall Surface/TV Guidelines	6
C. Tools and Supplies Needed	6
D. Inspect Appliance and Components	7

3 Framing and Clearances

A. Appliance/Decorative Front Dimension Diagrams	8
B. Clearances to Combustibles	10
C. Constructing the Appliance Chase	11
D. Hearth Extension	12
E. Floor Protection	13

4 Termination Location and Vent Information

A. Vent Termination Minimum Clearances	14
B. Chimney Diagram	15
C. Approved Pipe	16
D. Use of Elbows	17
E. Measuring Standards	18
F. Vent Diagrams	18
G. PVL P-SLP and PVI-SLP-B Information	22

5 Vent Clearances and Framing

A. Pipe Clearances to Combustibles	23
B. Wall Penetration Framing/Firestops	23
C. Ceiling Firestop/Floor Penetration Framing	24
D. Install Attic Insulation Shield	24

6 Appliance Preparation

A. Vent Collar Preparation	25
B. Non-Combustible Material Installation	26
C. Securing and Leveling the Appliance	26

7 Venting and Chimneys

A. Assemble Vent Sections	27
B. Assemble Slip Sections	28
C. Secure the Vent Sections	29
D. Disassemble Vent Sections	29
E. Vertical Termination Requirements	30
F. Horizontal Termination Requirements	31

8 Electrical Information

A. General Information	33
B. IntelliFire Touch® Ignition System Wiring	33

9 Gas Information

A. Fuel Conversion	35
B. Gas Pressure	35
C. Gas Connection and Gas Line Purging	35
D. High Altitude Installations	36
E. Air Shutter Setting	36
F. Service/Replace Appliance Gas Valve	36

10 Finishing

A. Facing Material	37
B. Mantel and Wall Projections	38
C. Decorative Fronts	39

11 Appliance Setup

A. Fixed Glass Assembly	40
B. Remove the Shipping Materials	42
C. Clean the Appliance	42
D. Accessories	42
E. Installing the Optional Heat-Zone® Gas Kit	42
F. Install Light Bulbs	43
G. Install Refractory	44
H. Install Teco-Sil (Glass Ember Rock)	45
I. Mystic Ember Placement	45
J. Install Logs	46
K. Ember/Mineral Wool Placement	49
L. IntelliFire Touch® Control System Setup	49
M. Install Outer Refractory Panels	50
N. Install Trim and/or Surround	50

12 Reference Materials

A. Vent Components Diagrams	51
B. Accessories	58

➔ = Contains updated information.

Installation Standard Work Checklist

ATTENTION INSTALLER: Follow this Standard Work Checklist

This standard work checklist is to be used by the installer in conjunction with, not instead of, the instructions contained in this installation manual.

Customer: _____
Lot/Address: _____
Model (circle one): ESC-42ST-IFT

Date Installed: _____
Location of Fireplace: _____
Installer: _____
Dealer/Distributor Phone # _____
Serial #: _____

WARNING! Risk of Fire or Explosion! Failure to install appliance according to these instructions could lead to a fire or explosion.

<u>Appliance Install</u>	YES	IF NO, WHY?
Verified that the chase is insulated and sealed. (Pg. 11)	<input type="checkbox"/>	_____
Required non-combustible board is installed. (Pg. 26)	<input type="checkbox"/>	_____
Verified clearances to combustibles. (Pg. 10-11)	<input type="checkbox"/>	_____
Fireplace is leveled and secured. (Pg. 26)	<input type="checkbox"/>	_____
 <u>Venting/Chimney Section 7 (Pg 27-32)</u>		
Venting configuration complies to vent diagrams.	<input type="checkbox"/>	_____
Venting installed, locked and secured in place with proper clearance.	<input type="checkbox"/>	_____
Firestops installed.	<input type="checkbox"/>	_____
Attic insulation shield installed.	<input type="checkbox"/>	_____
Exterior wall/Roof flashing installed and sealed.	<input type="checkbox"/>	_____
Terminations installed and sealed.	<input type="checkbox"/>	_____
 <u>Electrical Section 8 (Pg 33-34)</u>		
Unswitched power (110-120 VAC) provided to the appliance.	<input type="checkbox"/>	_____
Switch wires properly installed.	<input type="checkbox"/>	_____
 <u>Gas Section 9 (Pg 35-36)</u>		
Proper appliance for fuel type.	<input type="checkbox"/>	_____
Was a conversion performed?	<input type="checkbox"/>	_____
Leak check performed and inlet pressure verified.	<input type="checkbox"/>	_____
Verified proper air shutter setting for installation type.	<input type="checkbox"/>	_____
 <u>Finishing Section 10 (Pg 37-39)</u>		
Combustible materials not installed in non-combustible areas.	<input type="checkbox"/>	_____
Verified all clearances meet installation manual requirements.	<input type="checkbox"/>	_____
Mantels and wall projections comply with installation manual requirements.	<input type="checkbox"/>	_____
 <u>Appliance Setup Section 11 (Pg 40-50)</u>		
All packaging and protective materials removed (inside & outside of appliance).	<input type="checkbox"/>	_____
Refractories, logs, media and embers installed correctly.	<input type="checkbox"/>	_____
Glass assembly installed and secured.	<input type="checkbox"/>	_____
Accessories installed properly.	<input type="checkbox"/>	_____
Mesh, doors, or decorative front properly installed.	<input type="checkbox"/>	_____
Manual bag and all of its contents are removed from inside/under the appliance and given to party responsible for use and operation.	<input type="checkbox"/>	_____
Started appliance and verified no gas leaks exist.	<input type="checkbox"/>	_____

Hearth & Home Technologies recommends the following:

- Photographing the installation and copying this checklist for your file.
- That this checklist remain visible at all times on the appliance until the installation is complete.

Comments: Further description of the issues, who is responsible (Installer/ Builder/ Other Trades, etc) and corrective action needed _____

Comments Communicated to party responsible _____ by _____ on _____
 (Builder / Gen. Contractor/) (Installer) (Date)

➔ = Contains updated information.

1 Product Specific and Important Safety Information

A. Appliance Certification

MODELS: ESC-42ST-IFT
LABORATORY: Underwriters Laboratories, Inc. (UL)
TYPE: Direct Vent Heater
STANDARD: CSA / ANSI Z21.88-2019 • CSA 2.33-2019

This product is listed to ANSI standards for “Vented Gas Fireplace Heaters” and applicable sections of “Gas Burning Heating Appliances for Manufactured Homes and Recreational Vehicles”, and “Gas Fired Appliances for Use at High Altitudes”. Also Certified for Installation in a Bedroom or a Bedsitting Room.

NOTICE: *This installation must conform with local codes. In the absence of local codes you must comply with the National Fuel Gas Code, ANSI Z223.1-latest edition in the U.S.A. and the CAN/CGA B149 Installation Codes in Canada.*

NOT INTENDED FOR USE AS A PRIMARY HEAT SOURCE.
 This appliance is tested and approved as either supplemental room heat or as a decorative appliance. It should not be factored as primary heat in residential heating calculations.

B. Glass Specifications (Ceramic)

This appliance is equipped with 5 mm ceramic glass with an anti-reflective coating. Replace glass only with 5 mm ceramic glass with identical specifications. Please contact your dealer for replacement glass.

C. BTU Specifications

Models (U.S. or Canada)		Maximum Input BTU/h	Minimum Input BTU/h	Orifice Size (DMS)
ESC-42ST-IFT (NG)	(0-2000 FT)	57,500	43,500	24
ESC-42ST-IFT (Propane)	(0-2000 FT)	56,500	41,000	44

D. High Altitude Installations

NOTICE: *If the heating value of the gas has been reduced, these rules do not apply. Check with your local gas utility or authorities having jurisdiction.*

When installing above 2000 feet elevation:

- In the USA: Reduce input rate 4% for each 1000 feet above 2000 feet.
- In CANADA: Input ratings are certified without a reduction of input rate for elevations up to 4500 feet (1370 m) above sea level. Please consult provincial and/or local authorities having jurisdiction for installations at elevations above 4500 feet (1370 m).

Check with your local gas utility to determine proper orifice size.

E. Non-Combustible Materials Specification

Material which will not ignite and burn. Such materials are those consisting entirely of steel, iron, brick, tile, concrete, slate, glass or plasters, or any combination thereof.

Materials that are reported as passing **ASTM E 136, Standard Test Method for Behavior of Materials in a Vertical Tube Furnace at 750 °C** shall be considered non-combustible materials.

F. Combustible Materials Specification

Materials made of or surfaced with wood, compressed paper, plant fibers, plastics, or other material that can ignite and burn, whether flame proofed or not, or plastered or unplastered shall be considered combustible materials.

G. Electrical Codes

NOTICE: *This appliance must be electrically wired and grounded in accordance with local codes or, in the absence of local codes, with National Electric Code ANSI/NFPA 70-latest edition or the Canadian Electric Code CSA C22.1.*

- A 110-120 VAC circuit for this product must be protected with ground-fault circuit-interrupter protection, in compliance with the applicable electrical codes, when it is installed in locations such as in bathrooms or near sinks.

H. California

 **WARNING:** This product and the fuels used to operate this product (liquid propane or natural gas), and the products of combustion of such fuels, can expose you to chemicals including benzene, which is known to the State of California to cause cancer and reproductive harm. For more information go to: www.P65Warnings.ca.gov.

Note: The following requirements reference various Massachusetts and national codes not contained in this document.

I. Requirements for the Commonwealth of Massachusetts

For all side wall horizontally vented gas fueled equipment installed in every dwelling, building or structure used in whole or in part for residential purposes, including those owned or operated by the Commonwealth and where the side wall exhaust vent termination is less than seven (7) feet above finished grade in the area of the venting, including but not limited to decks and porches, the following requirements shall be satisfied:

Installation of Carbon Monoxide Detectors

At the time of installation of the side wall horizontal vented gas fueled equipment, the installing plumber or gas fitter shall observe that a hard wired carbon monoxide detector with an alarm and battery back-up is installed on the floor level where the gas equipment is to be installed. In addition, the installing plumber or gas fitter shall observe that a battery operated or hard wired carbon monoxide detector with an alarm is installed on each additional level of the dwelling, building or structure served by the side wall horizontal vented gas fueled equipment. It shall be the responsibility of the property owner to secure the services of qualified licensed professionals for the installation of hard wired carbon monoxide detectors.

In the event that the side wall horizontally vented gas fueled equipment is installed in a crawl space or an attic, the hard wired carbon monoxide detector with alarm and battery back-up may be installed on the next adjacent floor level.

In the event that the requirements of this subdivision can not be met at the time of completion of installation, the owner shall have a period of thirty (30) days to comply with the above requirements; provided, however, that during said thirty (30) day period, a battery operated carbon monoxide detector with an alarm shall be installed.

Approved Carbon Monoxide Detectors

Each carbon monoxide detector as required in accordance with the above provisions shall comply with NFPA 720 and be ANSI/UL 2034 listed and IAS certified.

Signage

A metal or plastic identification plate shall be permanently mounted to the exterior of the building at a minimum height of eight (8) feet above grade directly in line with the exhaust vent terminal for the horizontally vented gas fueled heating appliance or equipment. The sign shall read, in print size no less than one-half (1/2) in. in size, "**GAS VENT DIRECTLY BELOW. KEEP CLEAR OF ALL OBSTRUCTIONS**".

Inspection

The state or local gas inspector of the side wall horizontally vented gas fueled equipment shall not approve the installation unless, upon inspection, the inspector observes carbon monoxide detectors and signage installed in accordance with the provisions of 248 CMR 5.08(2)(a)1 through 4.

Exemptions

The following equipment is exempt from 248 CMR 5.08(2)(a)1 through 4:

- The equipment listed in Chapter 10 entitled "Equipment Not Required To Be Vented" in the most current edition of NFPA 54 as adopted by the Board; and
- Product Approved side wall horizontally vented gas fueled equipment installed in a room or structure separate from the dwelling, building or structure used in whole or in part for residential purposes.

MANUFACTURER REQUIREMENTS

Gas Equipment Venting System Provided

When the manufacturer of Product Approved side wall horizontally vented gas equipment provides a venting system design or venting system components with the equipment, the instructions provided by the manufacturer for installation of the equipment and the venting system shall include:

- Detailed instructions for the installation of the venting system design or the venting system components; and
- A complete parts list for the venting system design or venting system.

Gas Equipment Venting System NOT Provided

When the manufacturer of a Product Approved side wall horizontally vented gas fueled equipment does not provide the parts for venting the flue gases, but identifies "special venting systems", the following requirements shall be satisfied by the manufacturer:

- The referenced "special venting system" instructions shall be included with the appliance or equipment installation instructions; and
- The "special venting systems" shall be Product Approved by the Board, and the instructions for that system shall include a parts list and detailed installation instructions.

A copy of all installation instructions for all Product Approved side wall horizontally vented gas fueled equipment, all venting instructions, all parts lists for venting instructions, and/or all venting design instructions shall remain with the appliance or equipment at the completion of the installation.

See Gas Connection section for additional Commonwealth of Massachusetts requirements.

2 Getting Started

A. Design and Installation Considerations

Heat & Glo direct vent gas appliances are designed to operate with all combustion air siphoned from outside of the building and all exhaust gases expelled to the outside. No additional outside air source is required.

Installation **MUST** comply with local, regional, state and national codes and regulations. Consult insurance carrier, local building inspector, fire officials or authorities having jurisdiction over restrictions, installation inspection and permits.

Before installing, determine the following:

- Where the appliance is to be installed.
- The vent system configuration to be used.
- Gas supply piping requirements.
- Electrical wiring requirements.
- Framing and finishing details.
- Whether optional accessories—devices such as a fan, wall switch, or remote control—are desired.

Installation and service of this appliance should be performed by qualified personnel. Hearth & Home Technologies recommends HHT Factory Trained or NFI certified professionals.



Improper installation, adjustment, alteration, service or maintenance can cause injury or property damage. For assistance or additional information, consult a qualified service technician, service agency or your dealer.

B. Good Faith Wall Surface/TV Guidelines

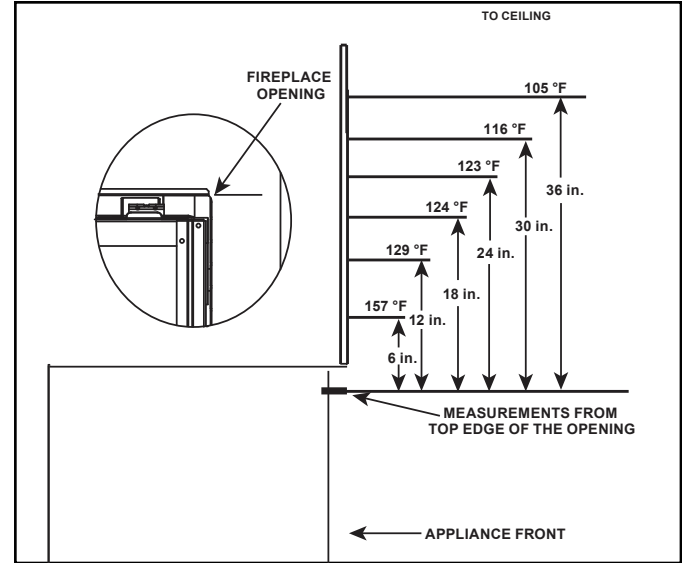

Figure 2.1 Good Faith Wall Surface Temperatures Above Appliance

NOTICE: Temperatures listed above are taken with a temperature measuring probe as prescribed by the test standard used for appliance certification. Temperatures on walls or mantels taken with an infrared thermometer may yield increased temperatures of up to 30 degrees or more depending on the thermometer settings and material characteristics being measured.

C. Tools and Supplies Needed

Before beginning the installation be sure that the following tools and building supplies are available.

Tape measure	Framing material
Pliers	Hammer
Phillips screwdriver	Manometer
Gloves	Framing square
Voltmeter	Electric drill and bits (1/4 in.)
Plumb line	Safety glasses
Level	Reciprocating saw

Flat blade screwdriver

Non-corrosive leak check solution

1/2 - 3/4 in. length, #6 or #8 Self-drilling screws

Caulking material (300 °F minimum continuous exposure rating)

One 1/4 in. female connection (for optional fan).

D. Inspect Appliance and Components

- Carefully remove the appliance and components from the packaging.
- The vent system components and decorative doors and fronts may be shipped in separate packages.
- If packaged separately, the log set and appliance grate must be installed.
- Report to your dealer any parts damaged in shipment, particularly the condition of the glass.
- This product is factory-equipped with an IntelliFire Touch® remote control, which was paired to the appliance at the factory. This specific remote control needs to remain with the contents of the manual bag. Do not install batteries in the remote control until performing the final appliance setup and checklist.
- **Read all of the instructions before starting the installation. Follow these instructions carefully during the installation to ensure maximum safety and benefit.**

WARNING! Risk of Fire or Explosion! Damaged parts could impair safe operation. **DO NOT** install damaged, incomplete or substitute components. Keep appliance dry.

Hearth & Home Technologies disclaims any responsibility for, and the warranty will be voided by, the following actions:

- Installation and use of any damaged appliance or vent system component.
- Modification of the appliance or vent system.
- Installation other than as instructed by Hearth & Home Technologies.
- Improper positioning of the gas logs or the glass door.
- Installation and/or use of any component part not approved by Hearth & Home Technologies.

Any such action may cause a fire hazard.

WARNING! Risk of Fire, Explosion or Electric Shock! **DO NOT** use this appliance if any part has been under water. Call a qualified service technician to inspect the appliance and to replace any part of the control system and/or gas control which has been under water.

3 Framing and Clearances

A. Appliance/Decorative Front Dimension Diagrams

Dimensions are actual appliance dimensions. Use for reference only. For framing dimensions and clearances refer to Section 5.

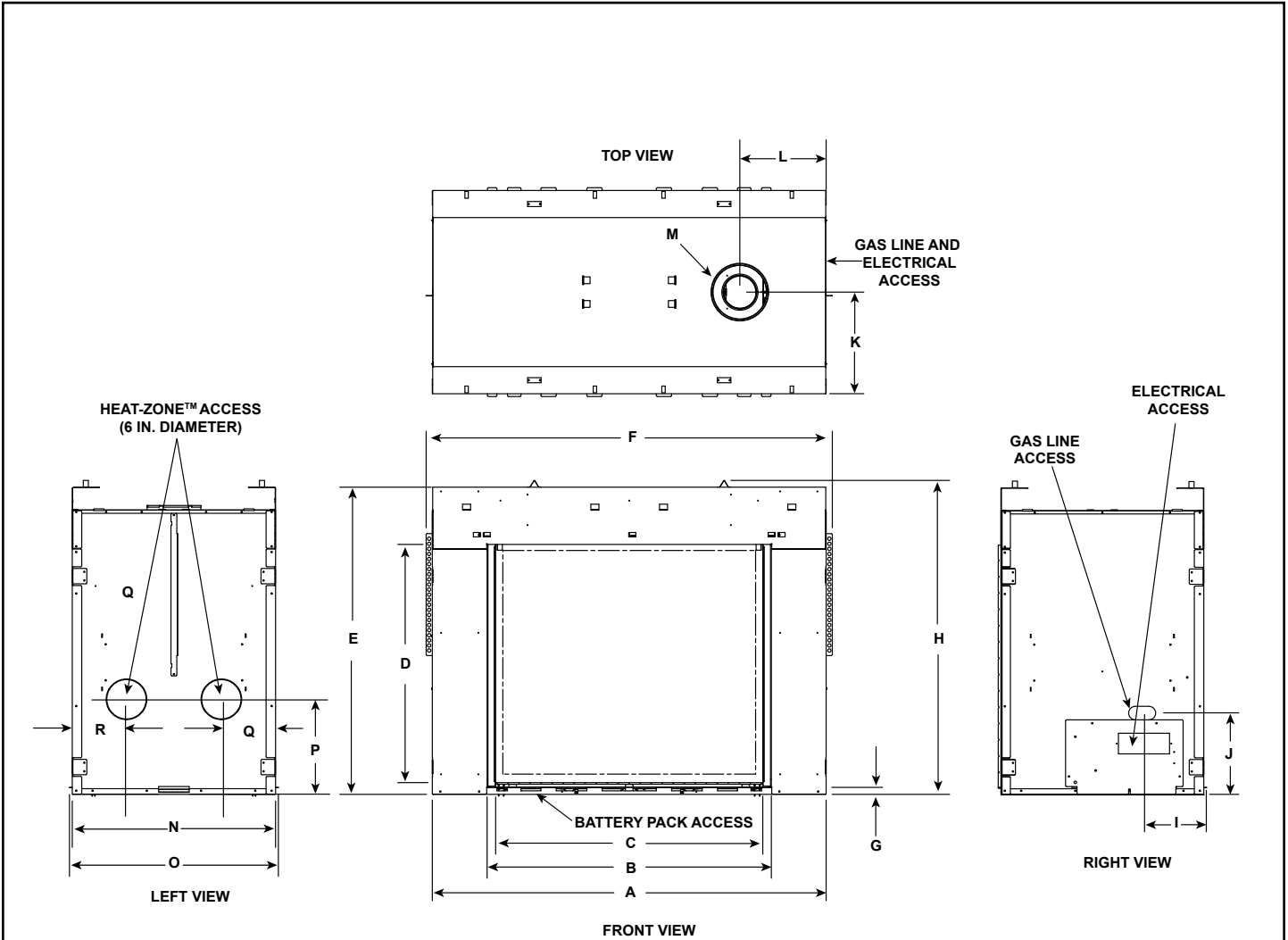

Appliance Dimensions Table

Location	Inches	Millimeters
A	58-1/8	1476
B	42	1067
C	39-7/16	1002
D	35-1/8	892
E	45-3/8	1153
F	60	1524
G	1	25
H	46-3/8	1178

Location	Inches	Millimeters
I	9-1/8	232
J	14	356
K	15	381
L	12-3/4	324
M	8 dia.	203
N	30	762
O	30-3/8	772
P	14-1/16	357
Q	8	203
R	8	203

Figure 3.1 Appliance Dimensions

DECORATIVE FRONT DIMENSION DIAGRAM - FS-42STIFT

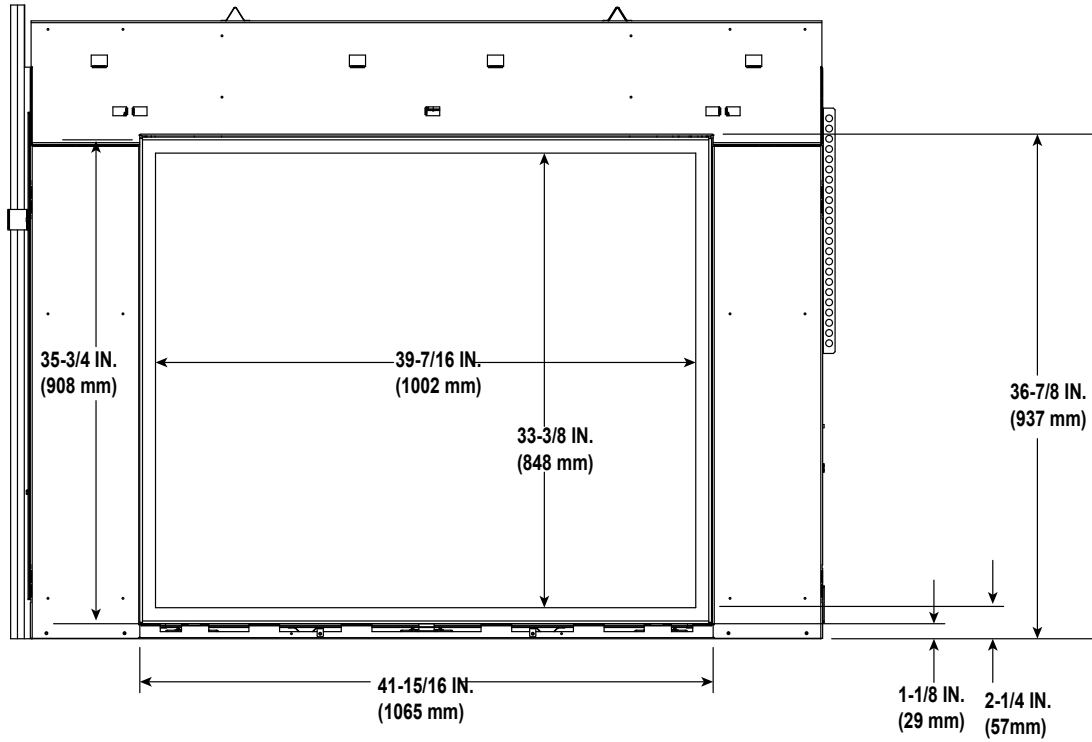

DECORATIVE FRONT DIMENSION DIAGRAM - FSA-42STIFT

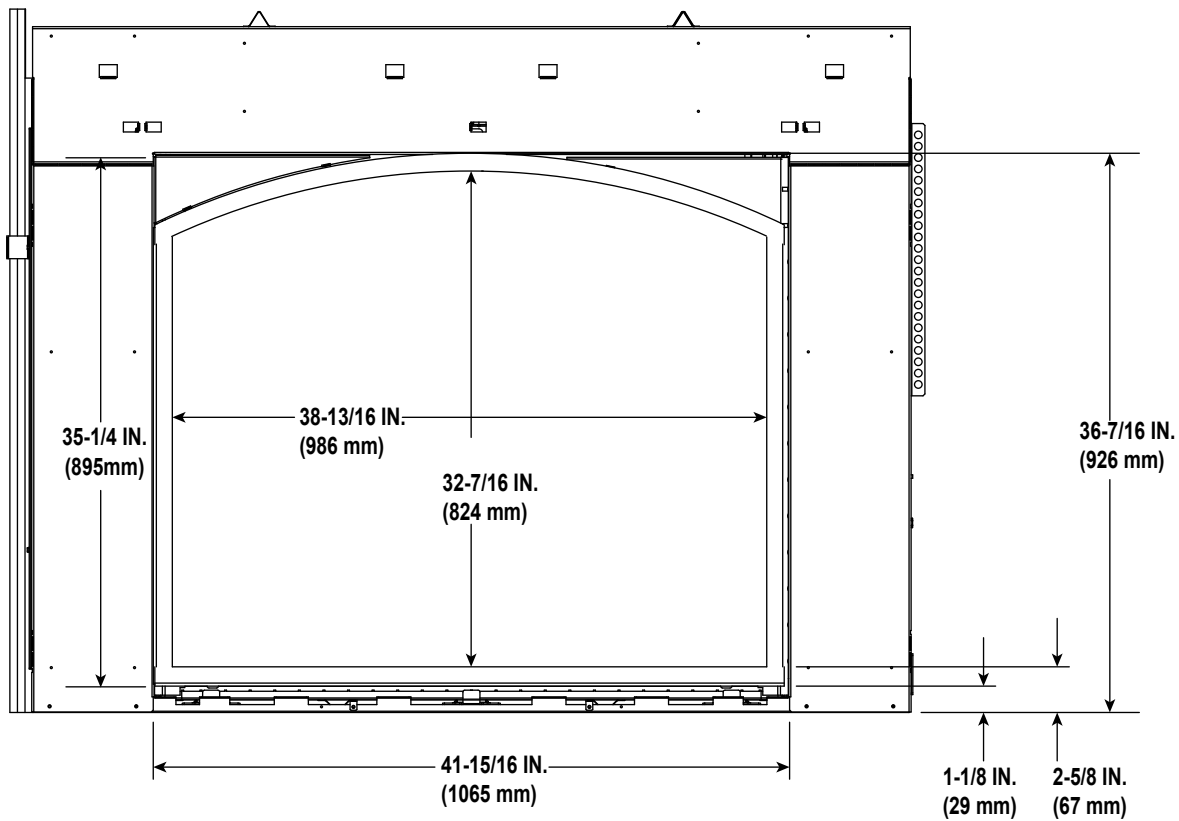

Figure 3.2 Decorative Front Dimensions - FS-42STIFT, FSA-42STIFT

B. Clearances to Combustibles

When selecting a location for the appliance it is important to consider the required clearances to walls (see Figure 3.3).

WARNING! Risk of Fire or Burns! Provide adequate clearance around air openings and for service access. Due to high temperatures, the appliance should be located out of traffic and away from furniture and draperies.

NOTICE: Illustrations reflect typical installations and are FOR DESIGN PURPOSES ONLY. Illustrations/diagrams are not drawn to scale. Actual installation may vary due to individual design preference.

NOTICE: This See-Through appliance is NOT designed or approved for an indoor/outdoor application.

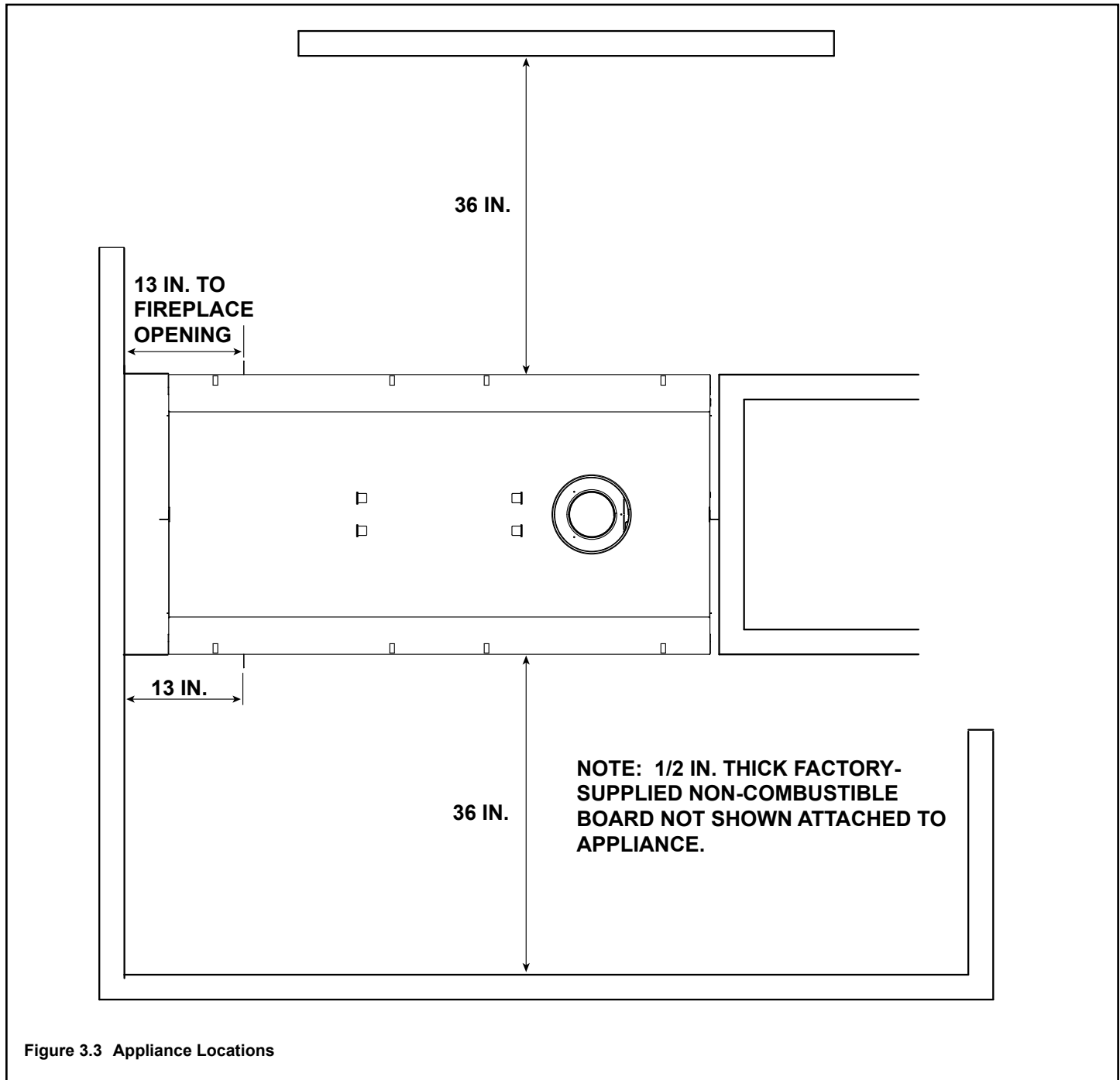
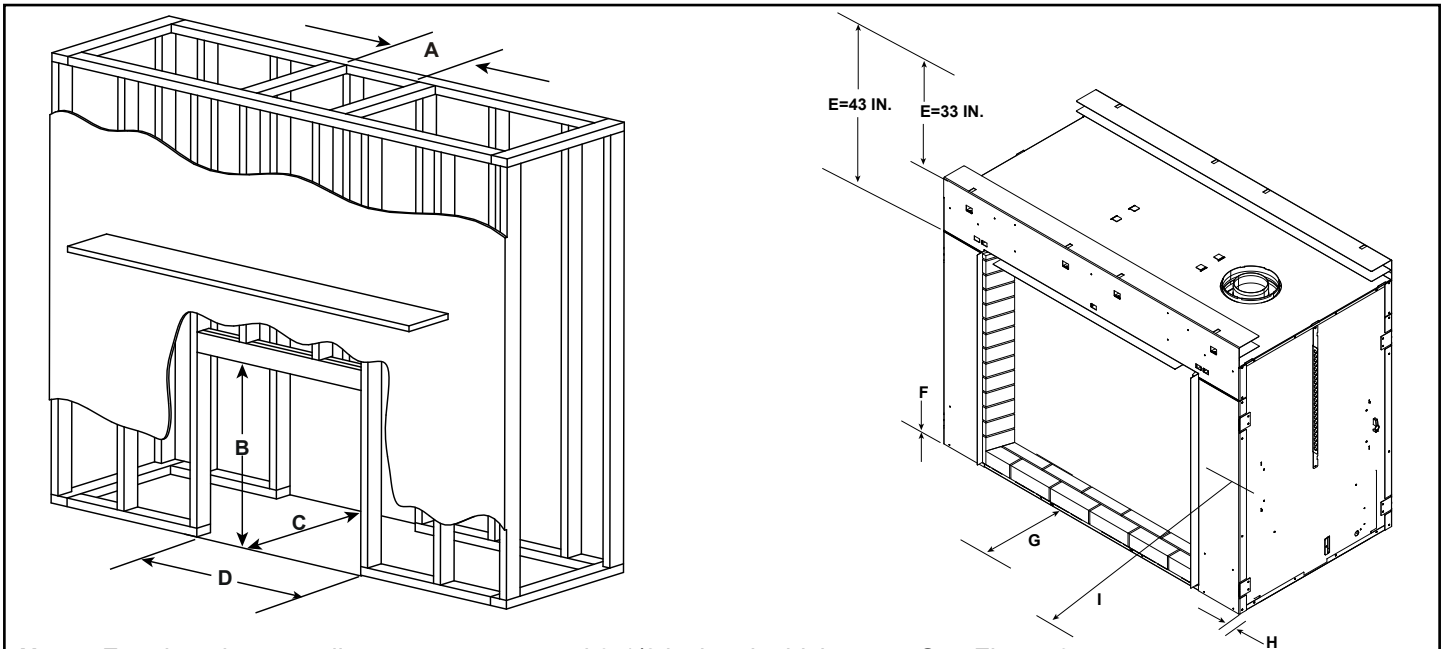

Figure 3.3 Appliance Locations



Note: Framing above appliance can not exceed 3-1/2 inches in thickness. See Figure 3.7.

MINIMUM FRAMING DIMENSIONS*										
	A	B**	C*	D	E		F**	G**	H	I
	Rough Opening (Vent Pipe)	Rough Opening (Height)	Rough Opening (Depth)	Rough Opening (Width)	Clearance to ceiling from opening	Clearance to ceiling from top of appliance	Combustible Floor	Combustible Flooring	Sides of Appliance	Front of Appliance
Inches	10	46-1/2	30	60-1/4	43	33	0	See Note Below	1	36
Millimeters	254	1181	762	1530	1092	838	0	See Note Below	25	914

* Adjust framing dimensions for interior sheathing (such as sheetrock)

** Fireplace may need to be elevated from the floor affecting framing height B, depending on hearth construction. See Section 3.D for hearth and combustible floor requirements. For installations with vinyl flooring, special clearance requirements apply. See Section 3.E.

Figure 3.4 Clearances to Combustibles

C. Constructing the Appliance Chase

A chase is a vertical box-like structure built to enclose the gas appliance and/or its vent system. In cooler climates the vent should be enclosed inside the chase.

NOTICE: Treatment of ceiling firestops and wall shield firestops and construction of the chase may vary with the type of building. These instructions are not substitutes for the requirements of local building codes. Therefore, you **MUST** check local building codes to determine the requirements to these steps.

NOTICE: Where required by code, install only sprinkler heads with a sprinkler activation temperature classified as **Extra High**.

- Sprinklers inside of chase: Keep sprinkler head away from vent and chimney.
- Heat Management applications: Maintain 36 inches of clearance to openings from which heat is discharged such as heat zone registers, etc.

Chases should be constructed and insulated in the same manner as the thermal envelope of the home based on the code requirements for that climate zone to prevent air leakage and draft problems. The chase is an extension of

the building thermal envelope.

To further prevent drafts and air leakage, the wall shield and ceiling firestops should be caulked with caulk with a minimum of 300 °F continuous exposure rating to seal gaps. Gas line holes and other openings should be caulked with caulk with a minimum of 300 °F continuous exposure rating or stuffed with unfaced insulation. If the appliance is being installed on a cement surface, a layer of plywood may be placed underneath to prevent conducting cold up into the room.

NOTICE: Install appliance on hard metal or wood surfaces extending full width and depth. **DO NOT** install directly on carpeting, vinyl, tile or any combustible material other than wood.

WARNING! Risk of Fire! Maintain specified air space clearances to appliance and vent pipe:

- Insulation and other materials must be secured to prevent accidental contact.
- The chase must be properly blocked to prevent blown insulation or other combustibles from entering and making contact with fireplace or chimney.
- Failure to maintain airspace may cause overheating and a fire.

D. Hearth Extension

WARNING! Risk of Fire! Hearth extension required to protect combustible floors in front of appliance.

WARNING! Risk of Fire! DO NOT block ventilation slots. A minimum 1/4 in. space between the bottom of hearth refractory and top of field installed hearth extension (marble, tile, granite, etc) is required across full width of fireplace.

If the appliance is to be placed directly on the floor, the non-combustible hearth material will be limited to 3/4 in. thick, including the floor adhesive. If the hearth material will exceed 3/4 in. thick, the appliance will need to be shimmed from the floor appropriately to maintain 1/4 in. minimum space between the floor hearth and hearth refractory.

The base of the fireplace may sit on a combustible surface. The area in front of the fireplace must be protected by a noncombustible hearth extension, unless the fireplace is raised a minimum of three inches above the combustible floor or hearth. See Figures 3.5, 3.6 and 3.8.

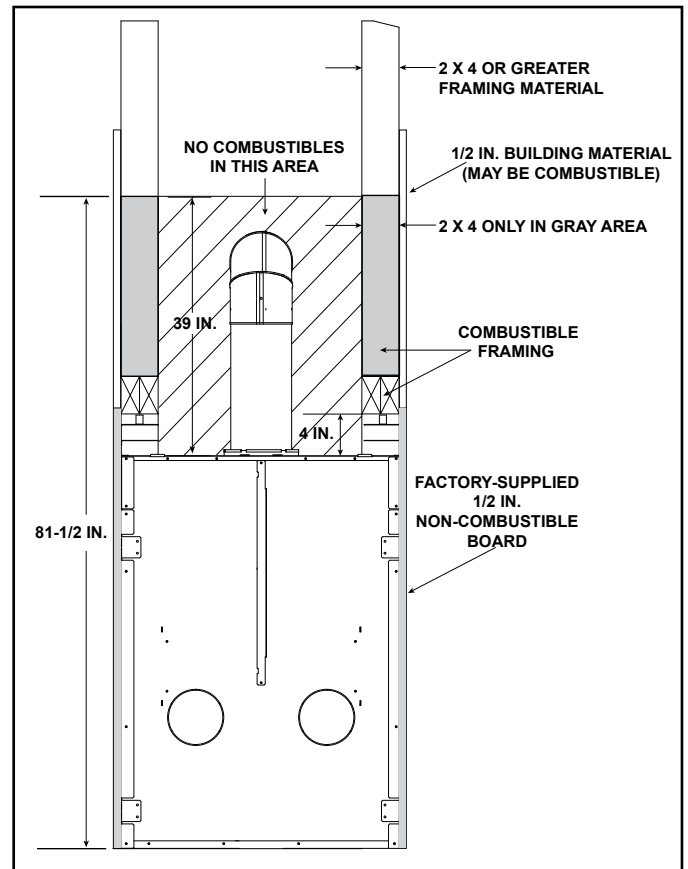

Figure 3.7 Non-Combustible Zone

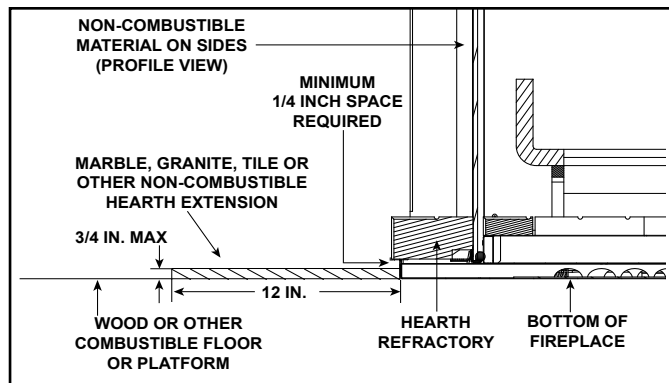

Figure 3.5 Fireplace Positioned on Combustible Surface

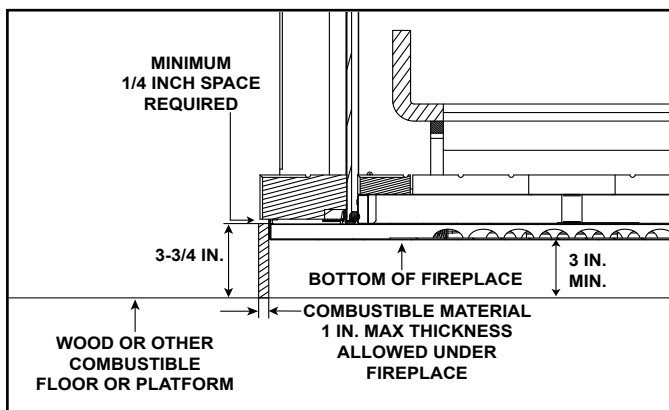

Figure 3.6 Fireplace Raised A Minimum of 3 Inches Above Combustible Surface

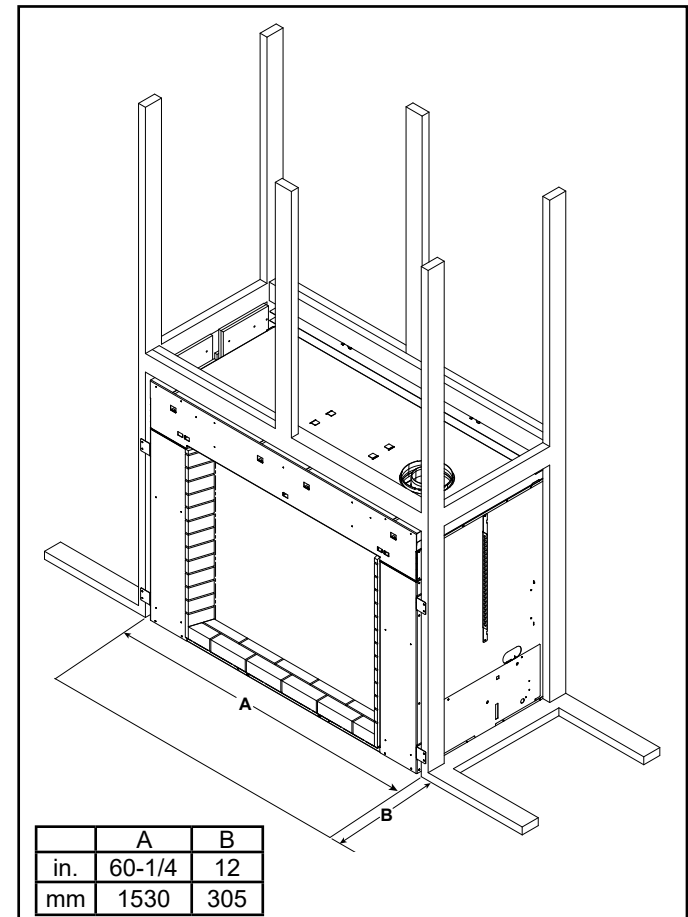

Figure 3.8 Non-Combustible Hearth Extension Minimum Dimensions (Fireplace Positioned on Combustible Surface)

E. Floor Protection

Vinyl Flooring

Vinyl flooring is sensitive to heat. To avoid damage to the vinyl flooring, a 12 inch minimum x 12 inch minimum hearth is recommended when using vinyl flooring up to the wall. See Figure 3.9. If no hearth is used, it is recommended to provide a minimum of 36 inches of clearance in front of the appliance to the vinyl flooring OR the bottom of the appliance should be raised a minimum of 24 inches off of the floor to allow the vinyl flooring to be installed up to the wall.

NOTICE: Clearances that do not meet the minimum guidelines could result in damage or buckling to the vinyl flooring and is done at the installer's or homeowner's risk.

Hearth and Home Technologies does not recommend adhesive based vinyl flooring products due to thermal expansion during operation. Floating style flooring can be used, but will reach temperatures up to 110 °F (based on ambient temperature of 70 °F). Consult the manufacturer's flooring specifications to ensure compatibility.

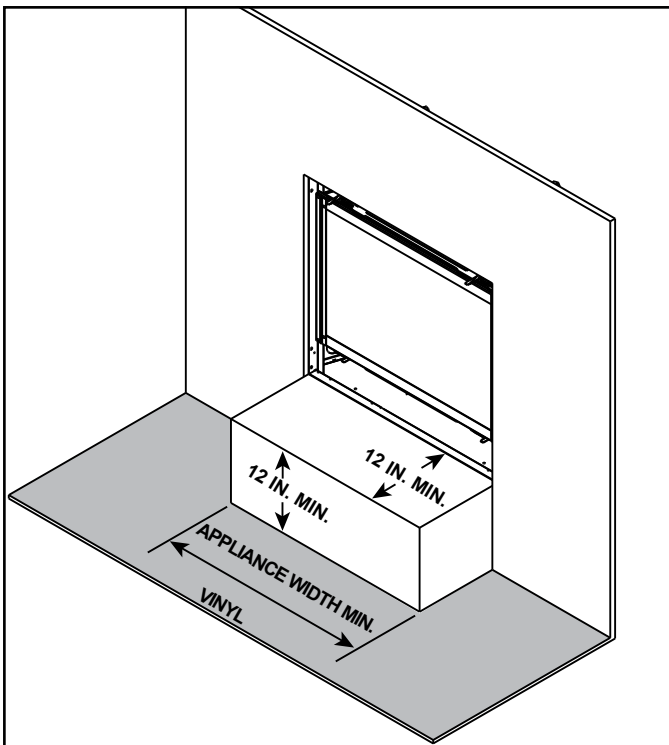

Figure 3.9 Vinyl Flooring Recommendations

4 Termination Location and Vent Information

A. Vent Termination Minimum Clearances

⚠ WARNING

Fire Risk.
Maintain vent clearance to combustibles as specified.

- **DO NOT** pack air space with insulation or other materials.

Failure to keep insulation or other materials away from vent pipe could cause overheating and fire.

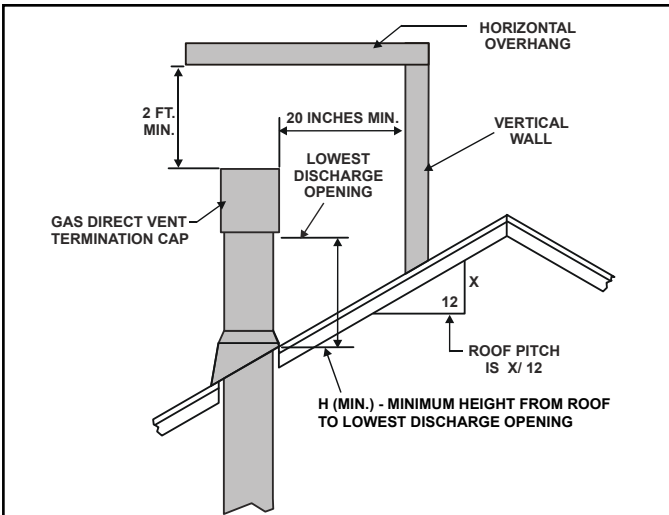

Roof Pitch	H (Min.) Ft.
Flat to 6/12.....	1.0*
Over 6/12 to 7/12.....	1.25*
Over 7/12 to 8/12.....	1.5*
Over 8/12 to 9/12.....	2.0*
Over 9/12 to 10/12.....	2.5*
Over 10/12 to 11/12.....	3.25
Over 11/12 to 12/12.....	4.0
Over 12/12 to 14/12.....	5.0
Over 14/12 to 16/12.....	6.0
Over 16/12 to 18/12.....	7.0
Over 18/12 to 20/12.....	7.5
Over 20/12 to 21/12.....	8.0

* H minimum may vary depending on regional snowfall. Refer to local codes.

Figure 4.1 Minimum Height From Roof to Lowest Discharge Opening

A	B
6 in. (minimum) up to 20 in. <i>152 mm/508 mm</i>	18 in. minimum <i>457 mm</i>
20 in. and over	0 in. minimum

* If two gas terminations are present, they may be level (B = 0 inches) provided A is a minimum of 6 inches.

Figure 4.2 Staggered Termination Caps

B. Chimney Diagram

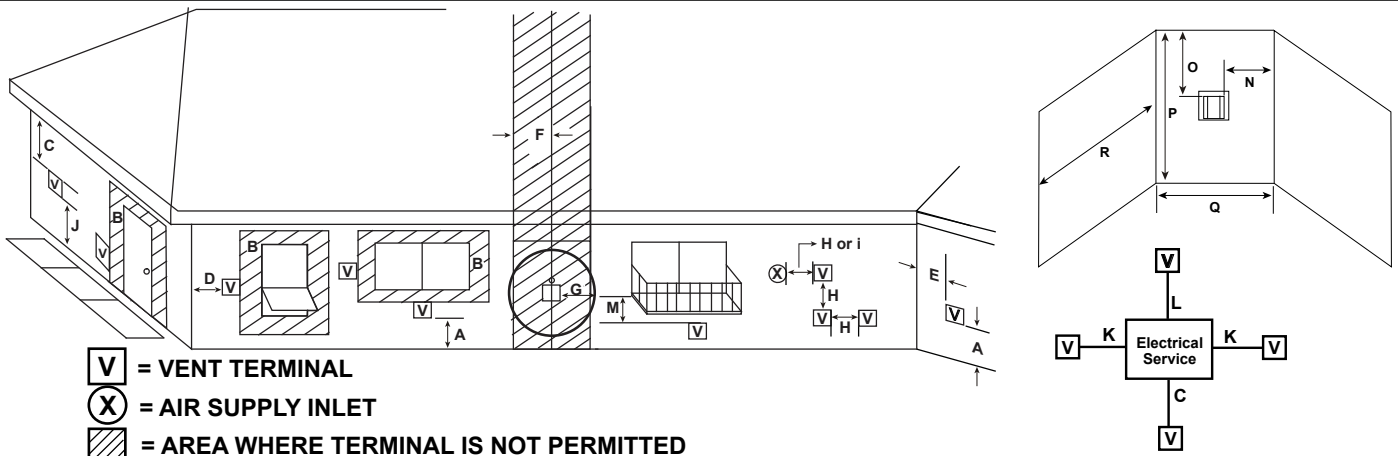

- V** = VENT TERMINAL
- X** = AIR SUPPLY INLET
- = AREA WHERE TERMINAL IS NOT PERMITTED

- A = 12 inches.....clearances above grade, veranda, porch, deck or balcony
- B = 12 inches.....clearance to window or door that may be opened, or to permanently closed window
- C = 18 inches.....clearance below unventilated soffit
18 inches.....clearance below ventilated soffit
30 inches.....clearance below vinyl soffits and electrical service
- D = 6 inches.....clearance to outside corner
- E = 6 inches.....clearance to inside corner
- F = 3 ft. (Canada).....not to be installed above a gas meter/regulator assembly within 3 feet horizontally from the center-line of the regulator
- G = 3 ft.....clearance to gas service regulator vent outlet
- H = 12 inches.....clearance to non-mechanical (unpowered) air supply inlet, combustion air inlet or direct-vent termination
- i = 3 ft. (U.S.A.)
6 ft. (Canada).....clearance to a mechanical (powered) air supply inlet

All mechanical air intakes within 10 feet of a termination cap must be a minimum of 3 feet below termination.

J = 7 ft. On **public** property: clearance above paved sidewalk or a paved driveway.

A vent shall not terminate directly above a sidewalk or paved driveway which is located between two single family dwellings and serves both dwellings.

- K = 6 inches.....clearance from sides of electrical service
- L = 12 inches.....clearance above electrical service
Location of the vent termination must not interfere with access to the electrical service.

M = 18 inches clearance under veranda, porch, deck, balcony or overhang
42 inchesvinyl or composite overhang
Permitted when veranda, porch, deck or balcony is fully open on a minimum of 2 sides beneath the floor.

Covered Alcove Applications

(Spaces open only on one side and with an overhang)

- N = 6 inches non-vinyl sidewalls
12 inches vinyl sidewalls
- O = 18 inches non-vinyl soffit and overhang
42 inches vinyl soffit and overhang
- P = 8 ft.

	Q _{MIN}	R _{MAX}
1 cap	3 feet	2 x Q _{ACTUAL}
2 caps	6 feet	1 x Q _{ACTUAL}
3 caps	9 feet	2/3 x Q _{ACTUAL}
4 caps	12 feet	1/2 x Q _{ACTUAL}

Q_{MIN} = # termination caps x 3 R_{MAX} = (2 / # termination caps) x Q_{ACTUAL}

H=Measure Horizontal Distances from H
V=Measure Vertical Distances from V

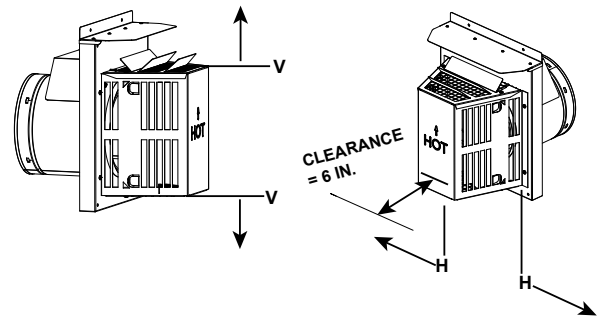

CAUTION! Risk of Burns! Termination caps are **HOT**, consider proximity to doors, traffic areas or where people may pass or gather (sidewalk, deck, patio, etc.). Listed cap shields available. Contact your dealer.

- Local codes or regulations may require different clearances.
- Vent system termination is **NOT** permitted in screened porches.
- Vent system termination is permitted in porch areas with two or more sides open.
- Hearth & Home Technologies assumes no responsibility for the improper performance of the appliance when the venting system does not meet these requirements.
- Vinyl protection kits are suggested for use with vinyl siding.

Figure 4.3 Minimum Clearances for Termination

C. Approved Pipe

This appliance is approved for use with Hearth & Home Technologies DVP venting systems. Refer to Section 12.A for vent component information and dimensions. Only use listed decorative termination caps/shrouds with Hearth & Home Technologies approved venting systems.

DO NOT mix pipe, fittings or joining methods from different manufacturers.

The pipe is tested to be run inside an enclosed wall. There is no requirement for inspection openings at each joint within the wall.

WARNING! Risk of Fire or Asphyxiation. *This appliance requires a separate vent. DO NOT vent to a pipe serving a separate solid fuel burning appliance.*

D. Use of Elbows

WARNING! Risk of Fire. This appliance requires a minimum of 24 inches of vertical venting before attaching any elbow to the appliance. **DO NOT** attach elbow directly to the appliance.

Diagonal runs have both vertical and horizontal vent aspects when calculating the effects. Use the rise for the vertical aspect and the run for the horizontal aspect. See Figure 4.4.

Two 45° elbows may be used in place of one 90° elbow. On 45° runs, one foot of diagonal is equal to 8-1/2 in. (216 mm) horizontal run and 8-1/2 in. (216 mm) vertical run. A length of straight pipe is allowed between two 45° elbows. See Figure 4.4.

Figure 4.5 shows the vertical and horizontal offsets for DVP elbows.

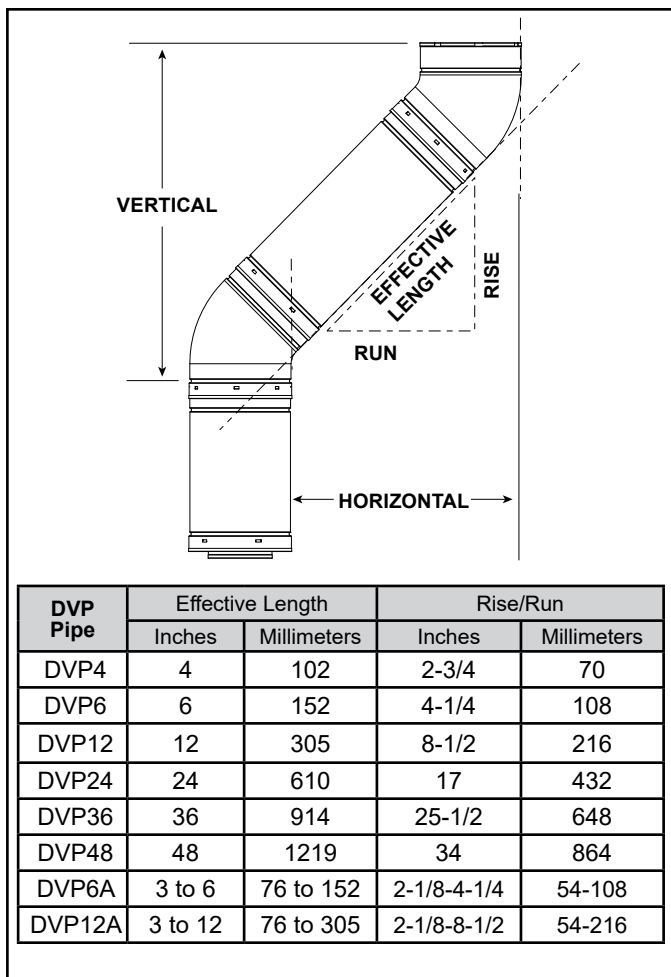

Figure 4.4

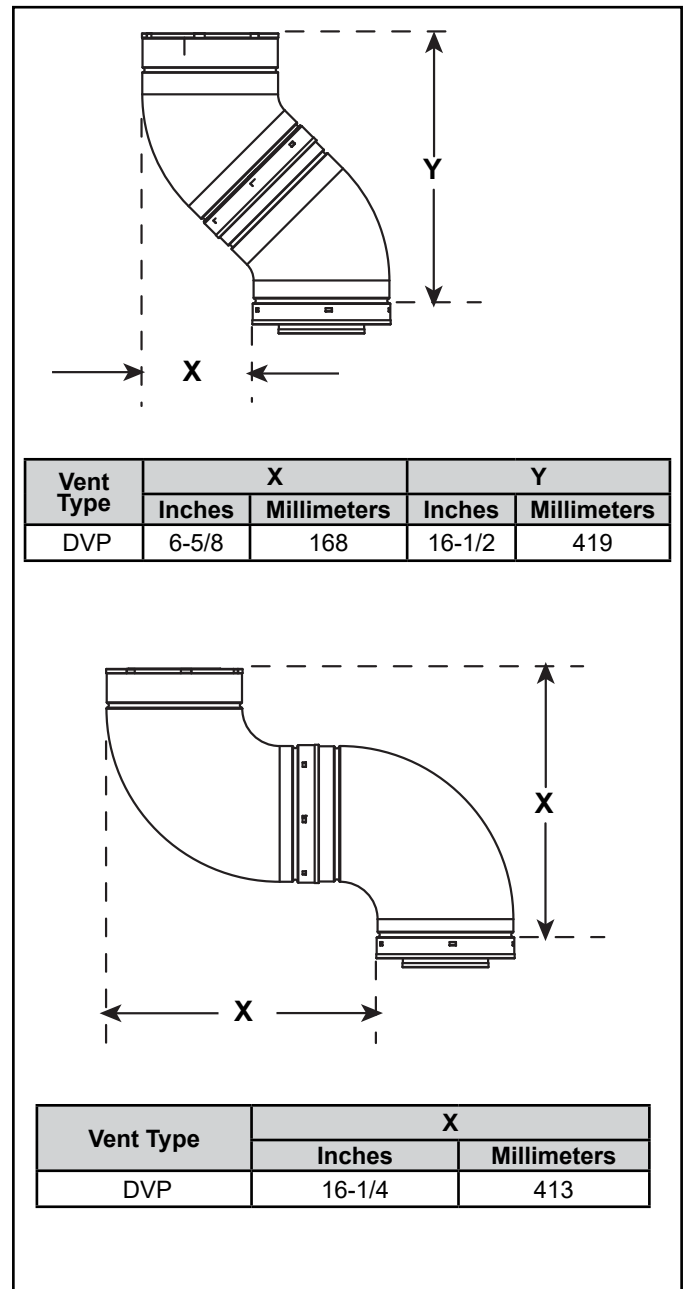

Figure 4.5 Vertical and Horizontal Offset for DVP and SLP Elbows

E. Measuring Standards

Vertical and horizontal measurements listed in the vent diagrams were made using the following standards:

- Pipe measurements are shown using the effective length of pipe. See Section 12.A (Figure 12.1) for information on effective length of pipe components.
- Horizontal terminations are measured to the outside mounting surface (flange of termination cap) (see Figure 4.6).
- Vertical terminations are measured to top of last section of pipe. See Figure 4.7.
- Horizontal pipe installed level with no rise.

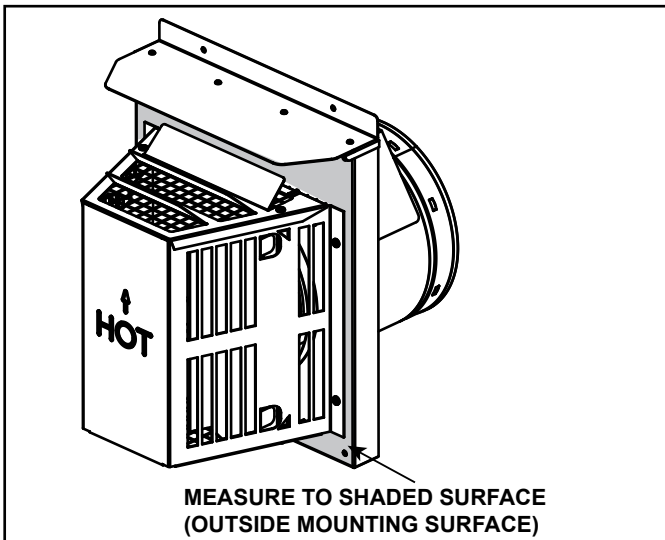

Figure 4.6 Measure to Outside Mounting Surface

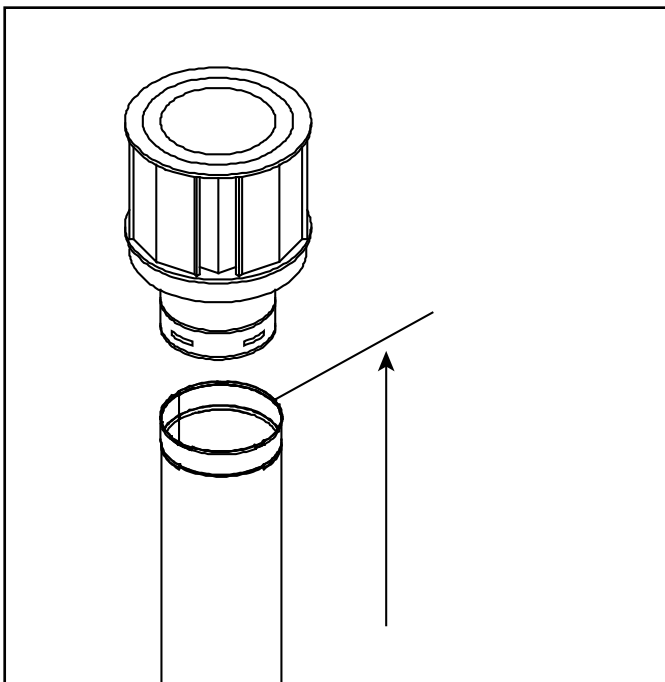

Figure 4.7. Measure to Top of Last Section of Pipe

F. Vent Diagrams

WARNING! Risk of Fire. This appliance requires a minimum of 24 inches of vertical venting before attaching any elbow to the appliance. **DO NOT** attach elbow directly to the appliance.

General Rules:

- This appliance is approved for use with Hearth & Home Technologies DVP venting systems ONLY.
- When penetrating a combustible wall, a wall shield firestop must be installed.
- When penetrating a combustible ceiling, a ceiling firestop must be installed.
- This appliance requires a minimum of 24 inches of vertical pipe attached directly to the appliance starting collar before attaching a 90 degree or 45 degree elbow.
- Horizontal termination cap should have a 1/4 inch downward slant to allow any moisture in cap to be released. See Figure 4.8.

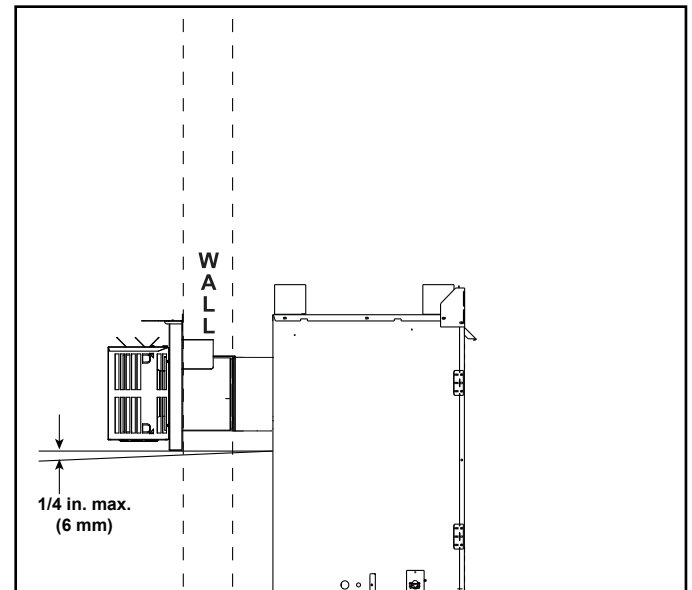

Figure 4.8

Top Vent - Horizontal Termination

⚠ WARNING



Fire Risk. Explosion Risk.

Do NOT pack insulation or other combustibles between ceiling firestops.

- ALWAYS maintain specified clearances around venting and firestop systems.
- Install wall shield and ceiling firestops as specified.

Failure to keep insulation or other material away from vent pipe may cause fire.

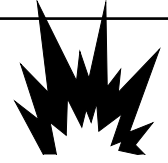

One Elbow

Note: Flue restrictor is permitted ONLY on 30 ft. minimum vertical runs with no elbows.

Note: Must have a 24 inches minimum vertical vent before attaching any elbow to the appliance.

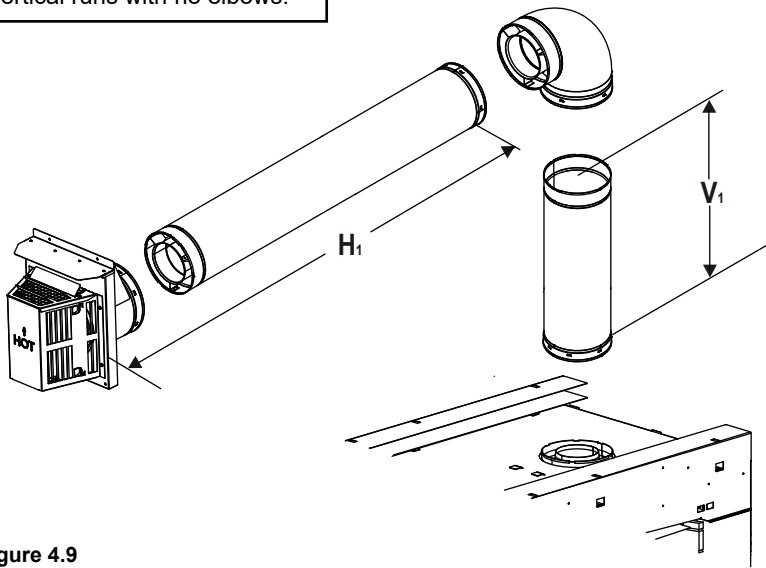

V ₁ Minimum		H ₁ Maximum	
2 ft	610 mm	7 in*	178 mm
3 ft	914 mm	2 ft	610 mm
4 ft	1.2 m	4 ft	1.2 m
5 ft	1.5 m	9 ft	2.7 m
6 ft	1.8 m	12 ft	3.7 m
7 ft	2.1 m	14 ft	4.3 m
10 ft	3.0 m	20 ft	6.1 m
20 ft	6.1 m	40 ft	12.2 m

After V₁ = 6 ft then H₁ = 2 x V₁ ft Maximum
 V₁ + H₁ = 60 ft Maximum
 *when used with approved termination caps

Figure 4.9

Two Elbows

Note: Flue restrictor is permitted ONLY on 30 ft. minimum vertical runs with no elbows.

Note: Must have a 24 inches minimum vertical vent before attaching any elbow to the appliance.

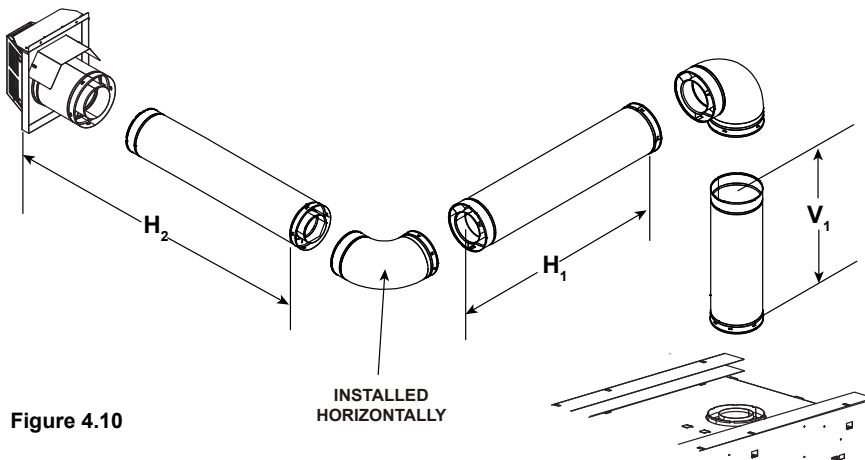

V ₁ Minimum		H ₁ + H ₂ Maximum	
3 ft	914 mm	18 in	457 mm
4 ft	1.2 m	3 ft	914 mm
5 ft	1.5 m	7 ft	2.1 m
6 ft	1.8 m	10 ft	3.0 m
7 ft	2.1 m	12 ft	3.7 m
10 ft	3.0 m	18 ft	5.5 m
20 ft	6.1 m	20 ft	6.1 m

After V₁ = 6 ft then H₁ = 2 x V₁ ft Maximum
 V₁ + H₁ + H₂ = 60 ft Maximum
 H₁ + H₂ = 20 ft Maximum

Figure 4.10

Top Vent - Horizontal Termination - (continued)

Three Elbows

Note: Must have a 24 inches minimum vertical vent before attaching any elbow to the appliance.

Note: Flue restrictor is permitted ONLY on 30 ft. minimum vertical runs with no elbows.

V ₁ Minimum		H ₁ Maximum		V ₂	H ₂
2 ft	610 mm	7 in	178 mm	*	H ₂ Max = 2 X V ₂
3 ft	914 mm	2 ft	610 mm	*	H ₂ Max = 2 X V ₂
4 ft	1.2 m	4 ft	1.2 m	*	H ₂ Max = 2 X V ₂
5 ft	1.5 m	9 ft	2.7 m	*	H ₂ Max = 2 X V ₂
6 ft	1.8 m	12 ft	3.7 m	*	H ₂ Max = 2 X V ₂
7 ft	2.1 m	14 ft	4.3 m	*	H ₂ Max = 2 X V ₂
10 ft	3.0 m	20 ft	6.1 m	*	H ₂ Max = 2 X V ₂

V₁ + H₁ must be adhered to.
 * V₂ has no specific restrictions EXCEPT,
 H_{t max} = 2 x V_t and V_{total} + H_{total} cannot exceed 60 ft Maximum

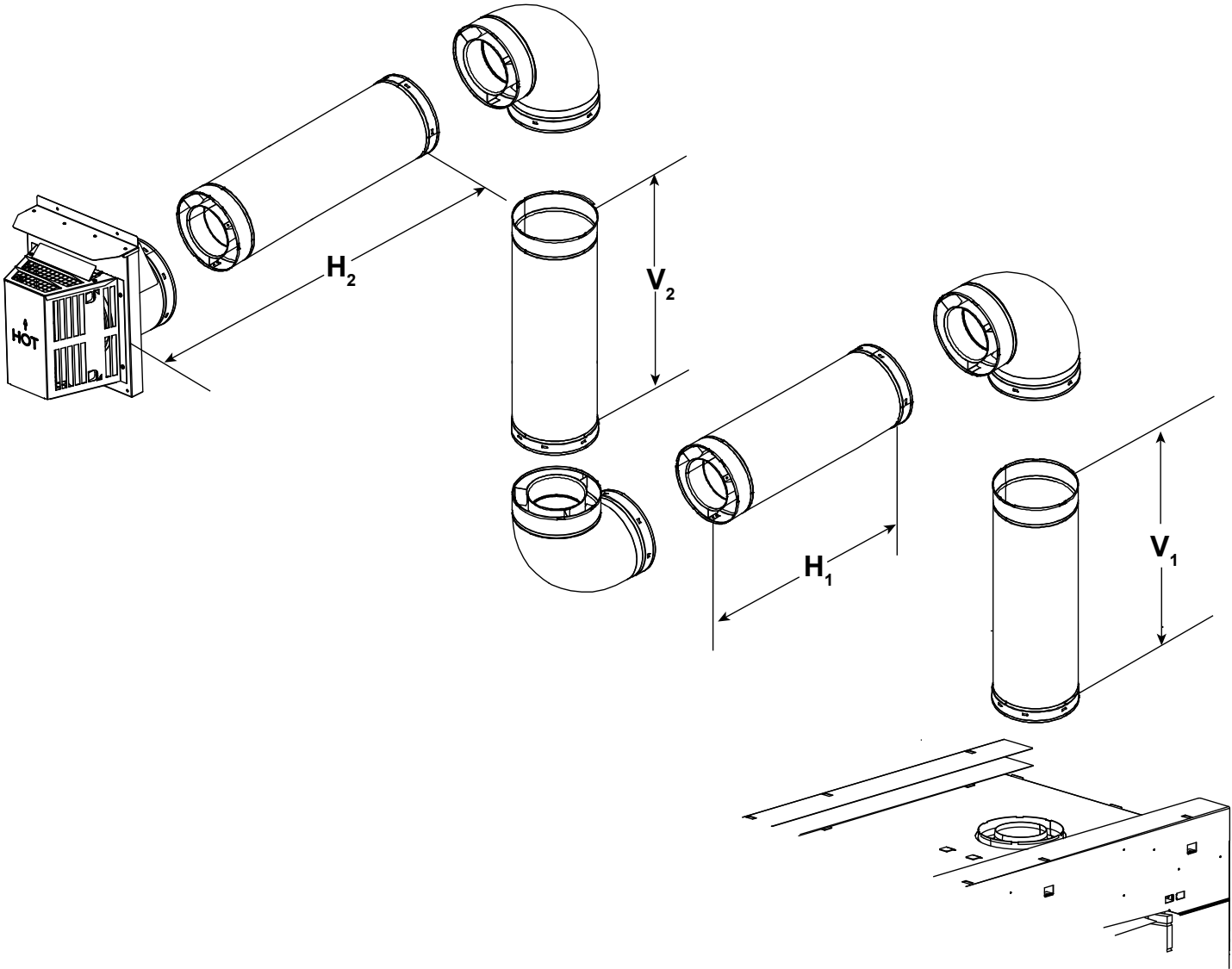

Figure 4.11

Top Vent - Vertical Termination

No Elbow

$V_1 = 50 \text{ ft. Max. (15.2 m)}$
 $V_1 = 3 \text{ ft. Min. (914 mm)}$

Note: Flue restrictor is permitted ONLY on 30 ft. minimum vertical runs with no elbows.

Note: Must have a 24 inches minimum vertical vent before attaching any elbow to the appliance.

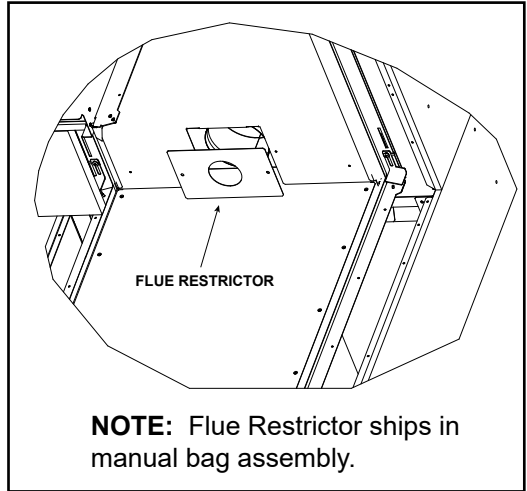
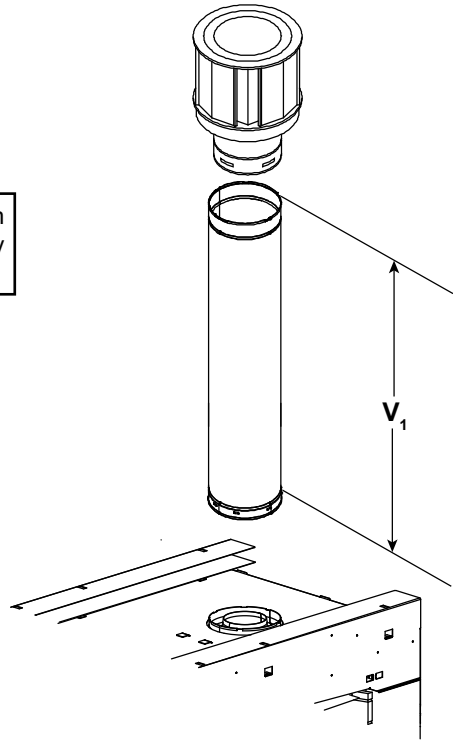
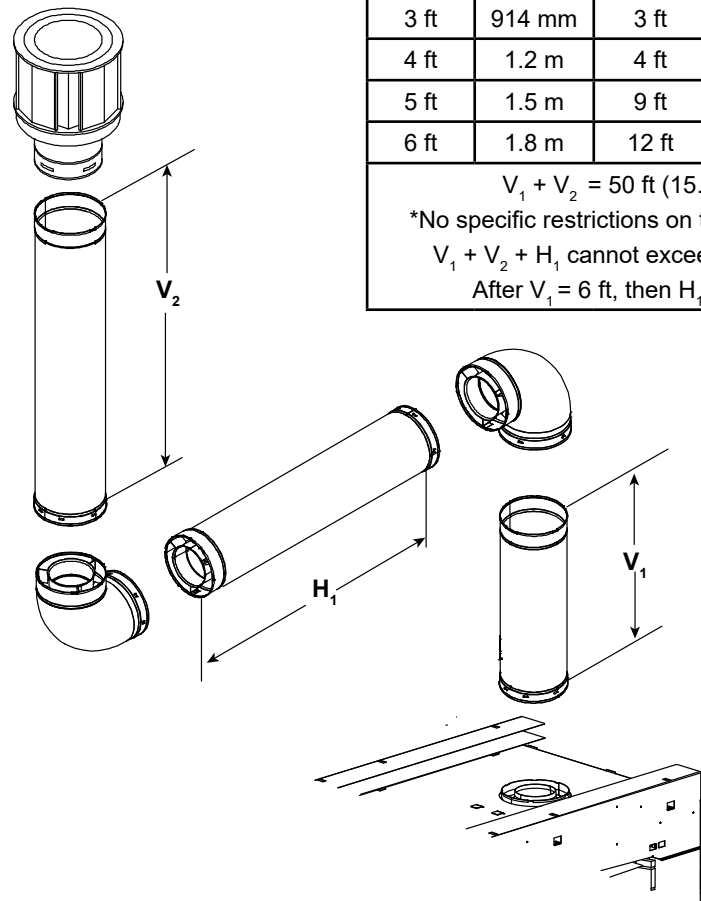

Figure 4.12

Note: Flue restrictor is permitted ONLY on 30 ft. minimum vertical runs with no elbows.

Note: Must have a 24 inches minimum vertical vent before attaching any elbow to the appliance.



V_1 Minimum		H_1 Maximum		V_2
2 ft	610 mm	1 ft	305 mm	*
3 ft	914 mm	3 ft	914 mm	*
4 ft	1.2 m	4 ft	1.2 m	*
5 ft	1.5 m	9 ft	2.7 m	*
6 ft	1.8 m	12 ft	3.7 m	*

$V_1 + V_2 = 50 \text{ ft (15.2 m) Max.}$
 *No specific restrictions on this value EXCEPT
 $V_1 + V_2 + H_1$ cannot exceed 60 ft (18.3 m).
 After $V_1 = 6 \text{ ft}$, then $H_1 \text{ Max.} = V_1 \times 2$

Figure 4.13

Three Elbows

Note: Flue restrictor is permitted ONLY on 30 ft. minimum vertical runs with no elbows.

Note: Must have a 24 inches minimum vertical vent before attaching any elbow to the appliance.

V_1 Minimum	H_1	H_2	V_2	H_{TOTAL} Maximum	
2 ft	610 mm	*	*	**	7 in / 178 mm
3 ft	914 mm	*	*	**	2 ft / 610 mm
4 ft	1.2 m	*	*	**	4 ft / 1.2 m
5 ft	1.5 m	*	*	**	8 ft / 2.4 m
6 ft	1.8 m	*	*	**	12 ft / 3.7 m
7 ft	2.1 m	*	*	**	14 ft / 4.3 m
10 ft	3.0 m	*	*	**	20 ft / 6.1 m

* H_1 and H_2 has no specific restrictions EXCEPT, after $V_1 = 6$ ft, then H_{TOTAL} Maximum = $2 \times V_1$
 ** $V_{TOTAL} + H_{TOTAL} = 60$ ft Maximum

G. PVLP-SLP and PVI-SLP-B Information

The ESC-42ST-IFT may be used with approved power vent kits. Follow instructions included with the PVLP-SLP or PVI-SLP-B power vent kits. See Table 4.1 below for approved Power Venting options for ESC-42ST-IFT models. Contact your dealer to order.

WARNING! Risk of Fire! Use ONLY Hearth & Home Technologies-approved power venting systems with this appliance. Use of power venting systems not approved by Hearth & Home Technologies may cause fireplace to overheat.

	PVLP-SLP	PVI-SLP-B
ESC-42ST-IFT	APPROVED	APPROVED

Table 4.1

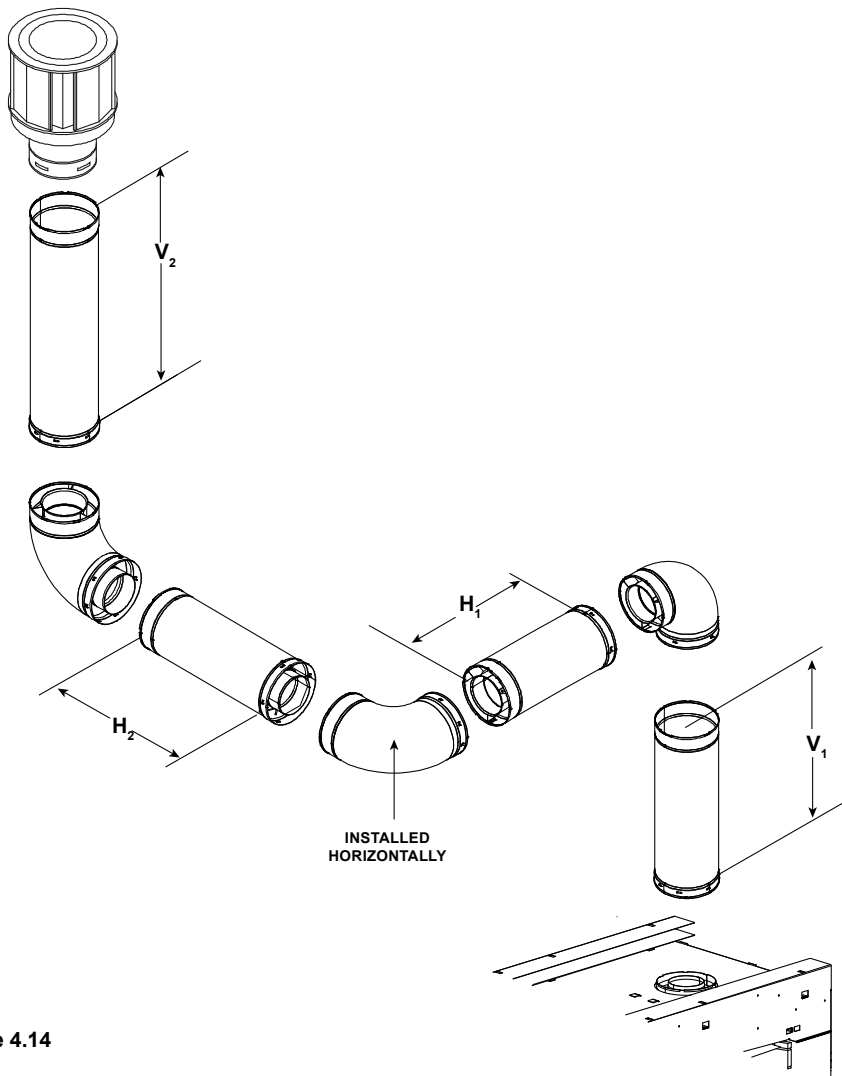

Figure 4.14

5 Vent Clearances and Framing

A. Pipe Clearances to Combustibles

WARNING! Risk of Fire! Maintain air space clearance to vent. DO NOT pack insulation or other combustibles:

- Between ceiling firestops
- Between wall shield firestops
- Around vent system

Failure to keep insulation or other material away from vent pipe could cause overheating and fire.

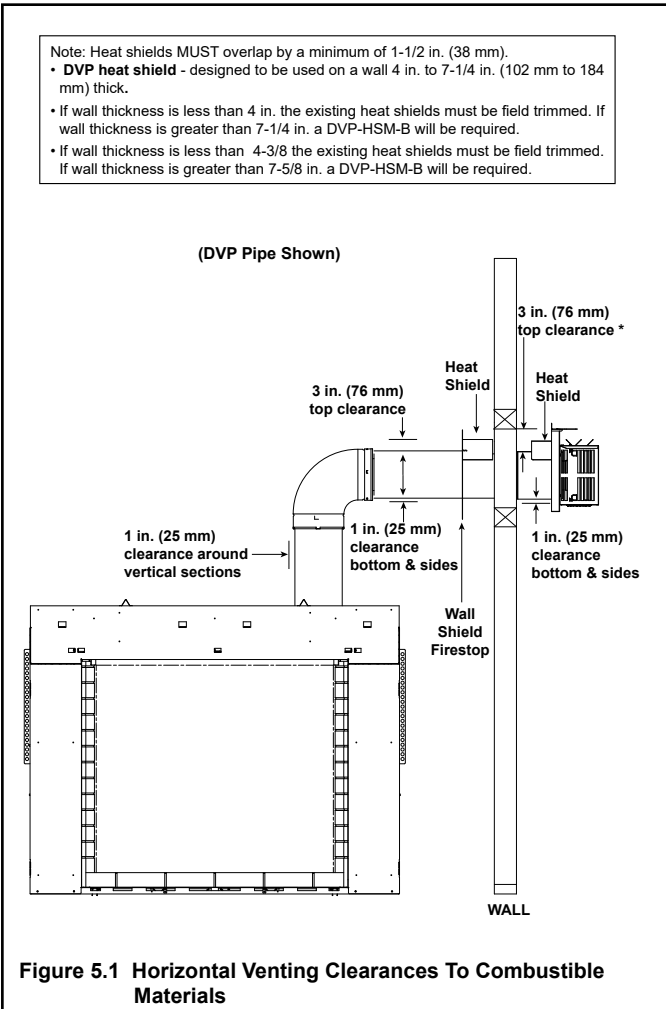

B. Wall Penetration Framing/Firestops

Combustible Wall Penetration

Whenever a combustible wall is penetrated, you must frame a hole for the wall shield firestop(s). The wall shield firestop maintains minimum clearances and prevents cold air infiltration.

- The opening must be framed on all four sides using the same size framing materials as those used in the wall construction.
- DVP pipe - A wall shield firestop is required on one side only on interior walls. If your local inspector requires a wall shield firestop on both sides, then both wall shield

firestops must have a heat shield attached to them. Refer to Section 12.A.

- See Section 7.F. for information for regarding the installation of a horizontal termination cap.

Non-Combustible Wall Penetration

If the hole being penetrated is surrounded by non-combustible materials such as concrete, a hole with diameter one inch greater than the pipe is acceptable.

Whenever a non-combustible wall is penetrated, the wall shield firestop is only required on one side and no heat shield is necessary.

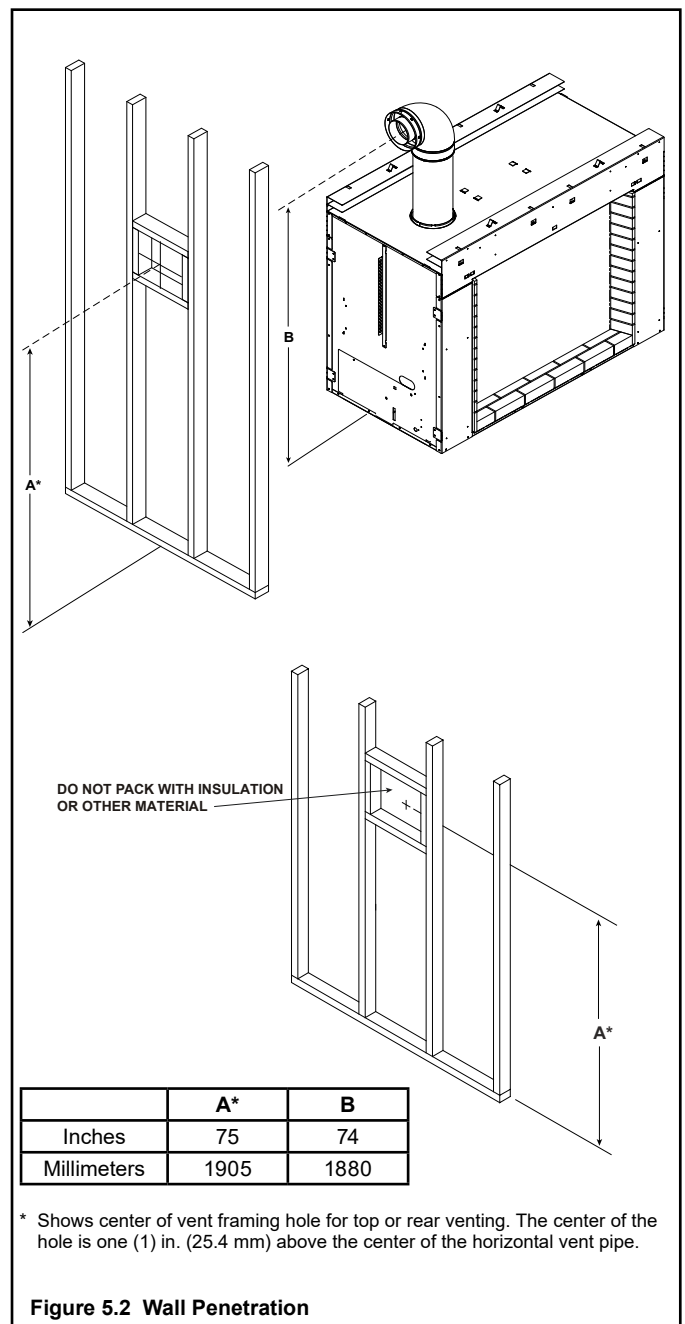

C. Ceiling Firestop/Floor Penetration Framing

A ceiling firestop **MUST** be used between floors and attics.

- **DVP pipe only** - Frame an opening 10 in. by 10 in. (254 mm by 254 mm) whenever the vent penetrates a ceiling/floor (see Figure 5.3).
- Frame the area with the same sized lumber as used in ceiling/floor joist.
- The ceiling firestop may be installed above or below the ceiling joists when installed with an attic insulation shield. It must be under joists between floors that are not insulated. Refer to Figure 5.4.
- Secure in place with nails or screws.

WARNING! Risk of Fire! DO NOT pack insulation around the vent. Insulation must be kept back from the pipe to prevent overheating.

D. Install Attic Insulation Shield

WARNING! Fire Risk. DO NOT allow loose materials or insulation to touch vent. Hearth & Home Technologies requires the use of an attic shield.

The International Fuel Gas Code requires an attic shield constructed of 26 gauge minimum steel that extends at least 2 in. (51 mm) above insulation.

- Attic insulation shields must meet specified clearances to combustible materials and be secured in place.
- An attic insulation shield kit is available from Hearth & Home Technologies. Contact your dealer to order. Install attic insulation shield according to instructions included with kit.

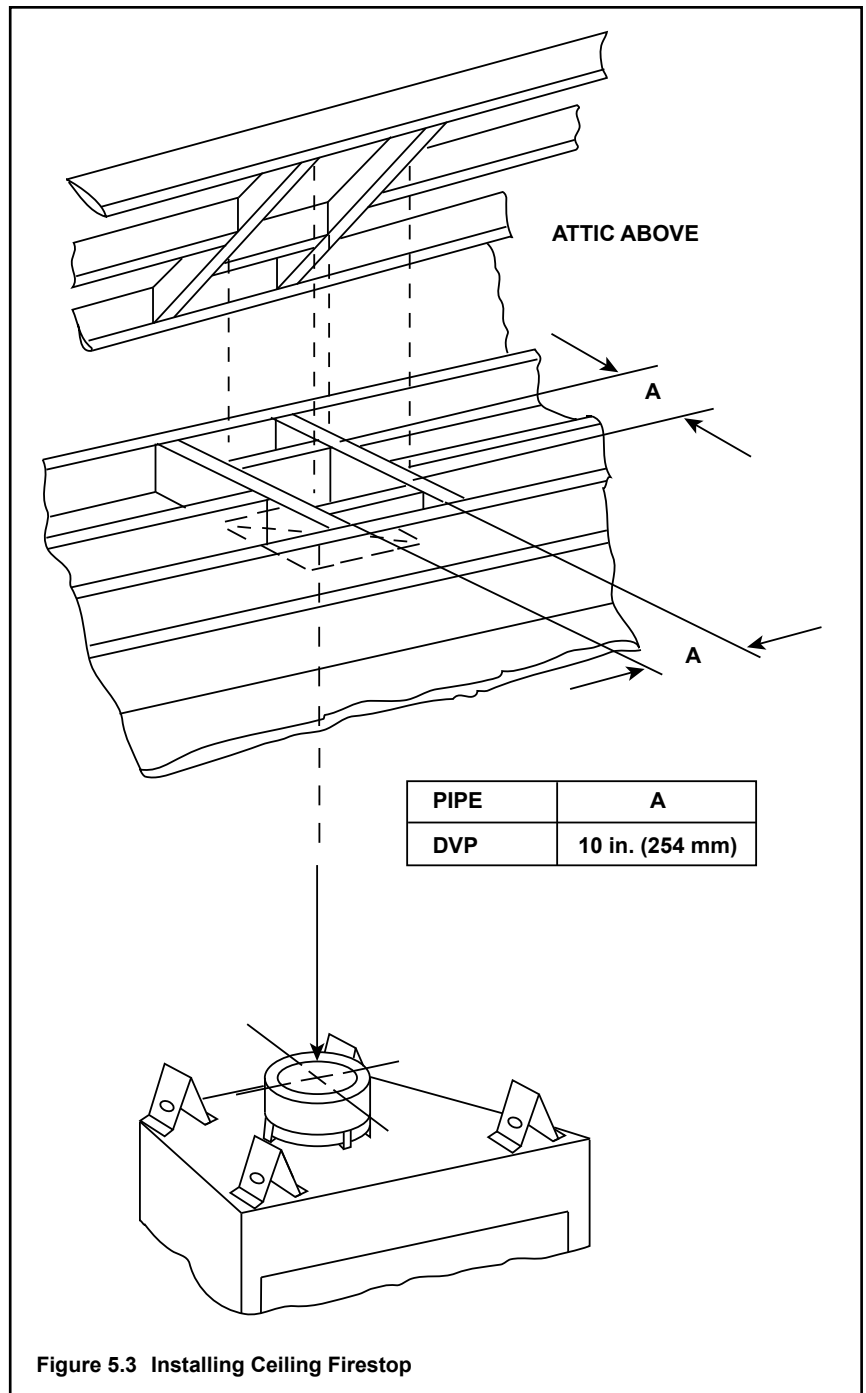

Figure 5.3 Installing Ceiling Firestop

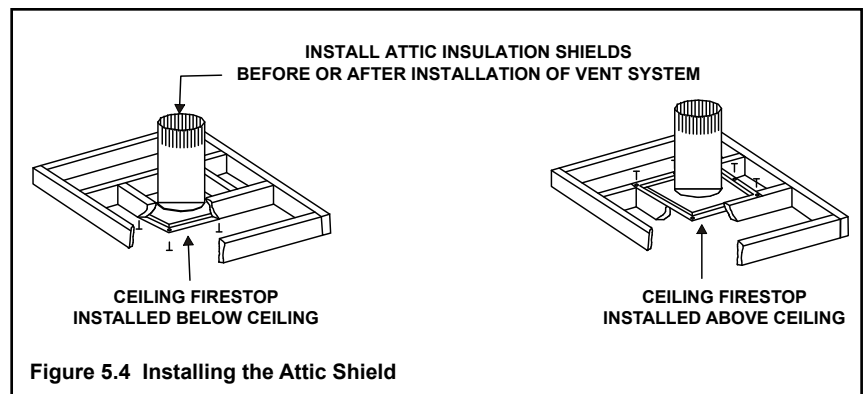

Figure 5.4 Installing the Attic Shield

6 Appliance Preparation

A. Vent Collar Preparation

CAUTION! Risk of Cuts, Abrasions or Flying Debris. Wear protective gloves and safety glasses during installation. Sheet metal edges are sharp.

NOTICE: This appliance is top vented ONLY.

1. Remove shrink wrap from appliance.



Figure 6.1 Packaged Appliance.

2. The seal cap, shown in Figure 6.2, is included to prevent construction material from getting into appliance. Remove seal cap when pipe installation phase begins.



Figure 6.2 Seal Cap.

3. Remove the two non-combustible assemblies by removing the two 1/4 in. screws fastening the non-combustible assemblies to the appliance. See Figure 6.3.

4. Six sheet metal finishing strips are included with the appliance. The shipping location of the finishing strips is shown in Figure 6.3. Remove 1/4 in. screws that attach the strips to the appliance. Strips may be used during the final finishing steps of appliance setup. See Figure 6.7. Strips should be removed when finishing is completed.



Figure 6.3 Shipping Brackets and Finishing Strip Locations.

4. Once the appliance is finished into the wall and is ready for final installation, remove the rest of the components.

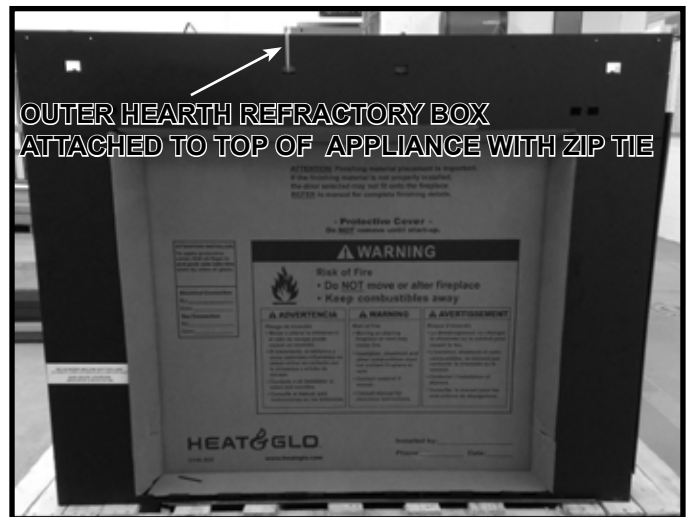

Figure 6.4.



Figure 6.5 Appliance Package Identification.

B. Non-Combustible Material Installation

Attach the non-combustible board to the appliance and wall framing with the screws supplied in the manual bag assembly. See Figure 6.6.

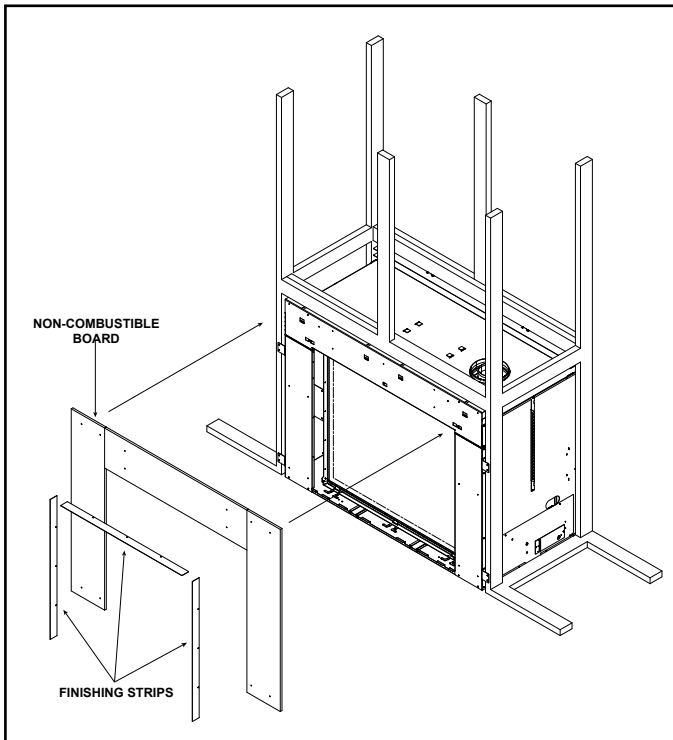

Figure 6.6 Attaching Non-Combustible Board

C. Securing and Leveling the Appliance

WARNING! Risk of Fire! Prevent contact with:

- Sagging or loose insulation
- Insulation backing or plastic
- Framing and other combustible materials

Block openings into the chase to prevent entry of blown-in insulation. Make sure insulation and other materials are secured.

DO NOT notch the framing around the appliance standoffs.

Failure to maintain air space clearance could cause overheating and fire.

The diagram shows how to properly position and secure the appliance. See Figure 6.7. Nailing tabs are provided to secure the appliance to the framing members.

- Bend out nailing tabs on each side.
- Place the appliance into position.
- Keep nailing tabs flush with the framing.
- Level the appliance from side to side and front to back.
- Shim the appliance as necessary. It is acceptable to use wood shims underneath the appliance.
- Secure the appliance to the framing by using nails or screws through the nailing tabs.
- Secure the appliance to the floor by inserting two screws through the pilot holes at the bottom of the appliance.
- Optional: Secure the appliance to the floor by inserting two screws through the pilot holes at the bottom of the appliance.

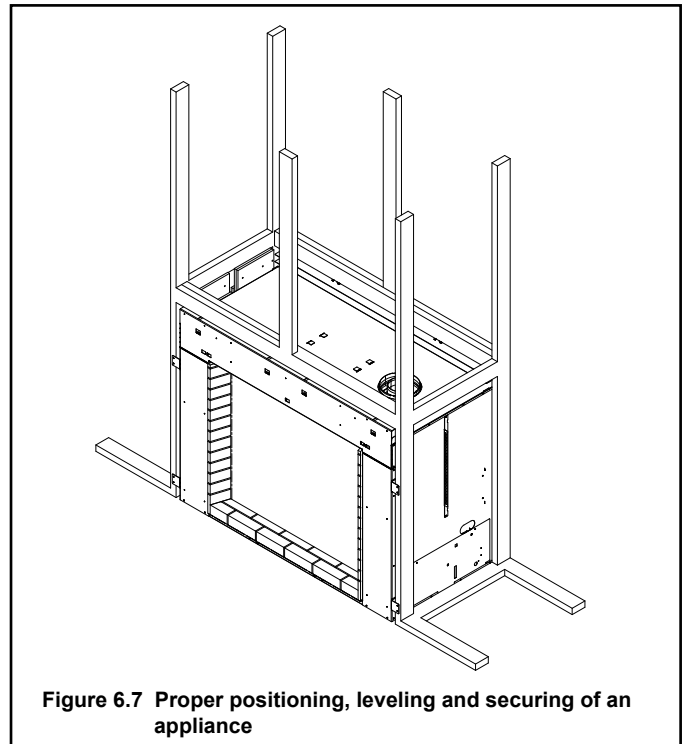

Figure 6.7 Proper positioning, leveling and securing of an appliance

7 Venting and Chimneys

A. Assemble Vent Sections (DVP Pipe Only)

Attach Vent to the Firebox Assembly

Note: The end of the pipe sections with the lanced tabs will face toward the appliance.

Attach the first pipe section to the starting collar:

- Lanced pipe end of the starting collar.
- Inner pipe over inner collar.
- Push the pipe section until all lanced tabs snap in place.
- Lightly tug on pipe to confirm it has locked.

Required Commercial, Multi-family (Multi-level exceeding two stories), or High-Rise Applications

All outer pipe joints must be sealed with 100% silicone (300 °F minimum continuous exposure rating), including the slip section that connects directly to the horizontal termination cap.

- Apply a bead of silicone sealant (300 °F minimum continuous exposure rating) inside the female outer pipe joint prior to joining sections. See Figure 7.1. **OR**

Apply a bead of silicone sealant (300 °F minimum continuous exposure rating) to the outside of connecting joint after joining sections **OR**

Apply aluminum foil tape (300 °F minimum continuous exposure rating) to the outside of connecting joint after joining sections. On horizontal pipe runs, it is recommended that the tape seam is positioned on the bottom side of the vent pipe.

- Only outer pipes need to be sealed. All unit collar, pipe, slip section, elbow and cap outer flues shall be sealed in this manner, unless otherwise stated.

WARNING! Risk of Fire or Explosion! DO NOT break silicone seals on slip sections. Use care when removing termination cap from slip pipe. If slip section seals are broken during removal of the termination cap, vent could leak.

Assemble Pipe Sections

Per Figure 7.2:

- Start the inner pipe on the lanced end of section A into the flared end of section B.
- Start the outer pipe of section A over the outer pipe of section B.
- Once both vents sections are started, push firmly until all lanced tabs lock into place.
- Lightly tug on the pipe to confirm the tabs have locked.

It is acceptable to use screws no longer than 1/2 in. (13 mm) to hold outer pipe sections together. If predrilling holes, **DO NOT** penetrate inner pipe.

For 90° and 45° elbows that are changing the vent direction

from horizontal to vertical, one screw minimum should be put in the outer flue at the horizontal elbow joint to prevent the elbow from rotating. Use screws no longer than 1/2 in. (13 mm). If predrilling screw holes, **DO NOT** penetrate inner pipe.



Figure 7.1 High Temperature Silicone Sealant

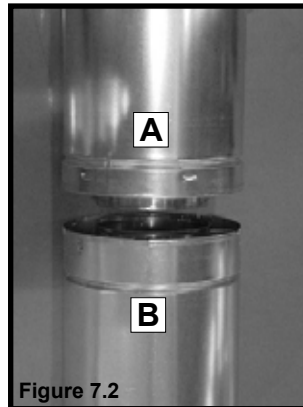

Figure 7.2

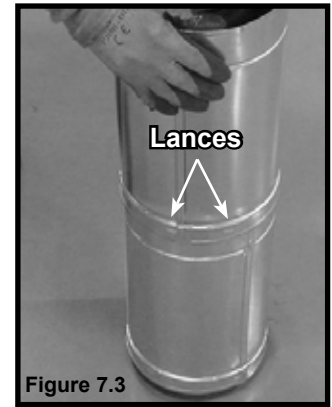
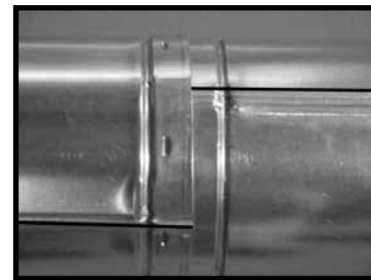

Figure 7.3

Note: Make sure that the seams are not aligned to prevent unintentional disconnection.



CORRECT

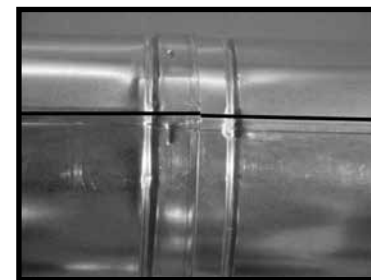

Figure 7.4 Seams

INCORRECT

B. Assemble Slip Sections

- Slide the inner flue of the slip section into the inner flue of the pipe section and the outer flue of the slip section over the outer flue of the pipe section. See Figure 7.6.
- Slide together to the desired length.

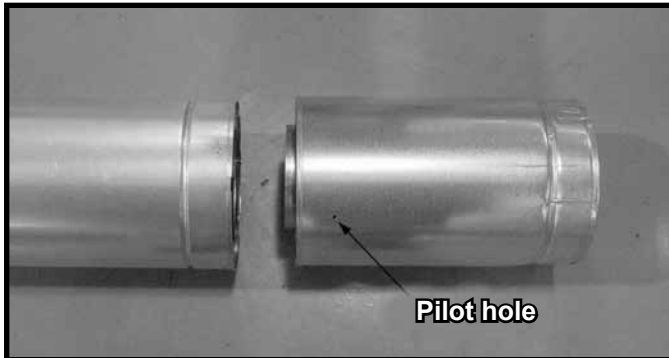

Figure 7.6 Slip Section Pilot Holes

- Maintain a 1-1/2 in. (38 mm) overlap between the slip section and the pipe section.
- Secure the pipe and slip section with two screws no longer than 1/2 in. (13 mm), using the pilot holes in the slip section. See Figure 7.7.

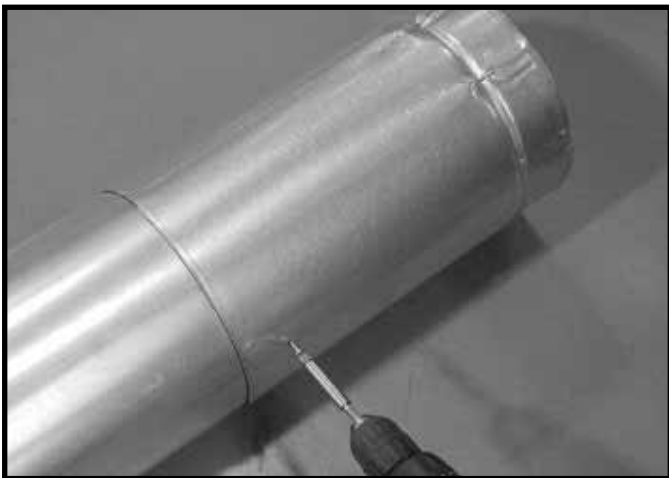

Figure 7.7 Screws into Slip Section

- Continue adding pipe as necessary following instructions in “Assembling Pipe Sections.”

NOTICE: If slip section is too long, the inner and outer flues of the slip section can be cut to the desired length.

NOTICE: When installing a vent system with an HRC termination cap, all pipe system joints shall be sealed using a high temperature silicone sealant (300 °F minimum continuous exposure rating).

- Apply a bead of silicone sealant (300 °F minimum continuous exposure rating) inside the female outer pipe joint prior to joining sections.
- Only outer pipes are sealed, sealing the inner flue is not required.
- All unit collar, pipe, slip section, elbow and cap outer flues shall be sealed.

C. Secure the Vent Sections

- Vertical runs originating off the top of the appliance, with no offsets, must be supported every 8 ft. (2.44 m) after the maximum allowed 25 ft. (7.62 m) of unsupported rise.
- Vertical runs originating off the rear of the appliance, or after any elbow, must be supported every 8 ft. (2.44 m).
- Horizontal runs must be supported every 5 feet (1.52 m).
- Vent supports or plumbers strap (spaced 120° apart) may be used to support vent sections. See Figures 7.8 and 7.9.
- Wall shield firestops may be used to provide horizontal support to vent sections.

WARNING! Risk of Fire, Explosion or Asphyxiation! Improper support could allow vent to sag and separate. Use vent run supports and connect vent sections per installation instructions. **DO NOT** allow vent to sag below connection point to appliance.

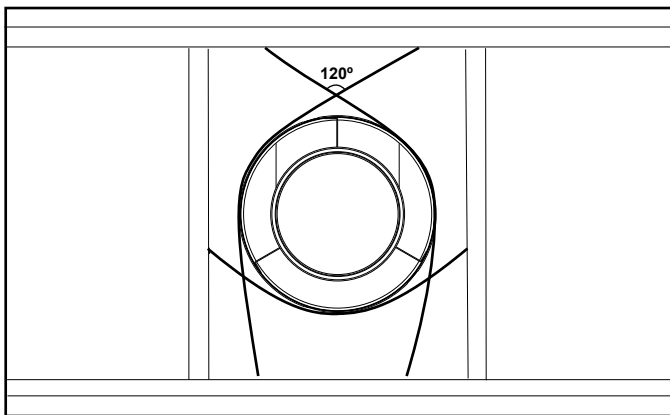

Figure 7.8 Securing Vertical Pipe Sections

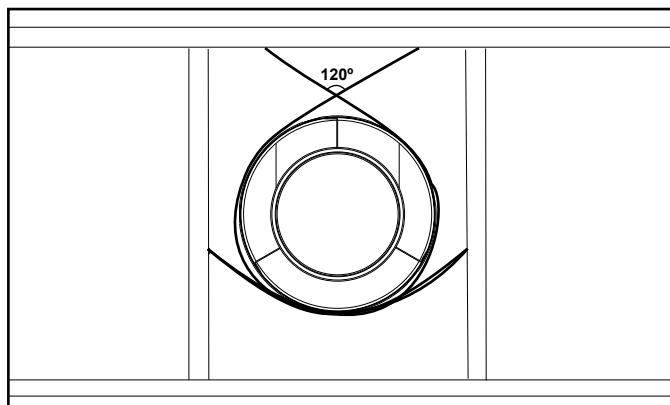

Figure 7.9 Securing Horizontal Pipe Sections

D. Disassemble Vent Sections

- Rotate either section (see Figure 7.10) so the seams on both pipe sections are aligned as shown in Figure 7.11.
- Pull carefully to separate the pieces of pipe.

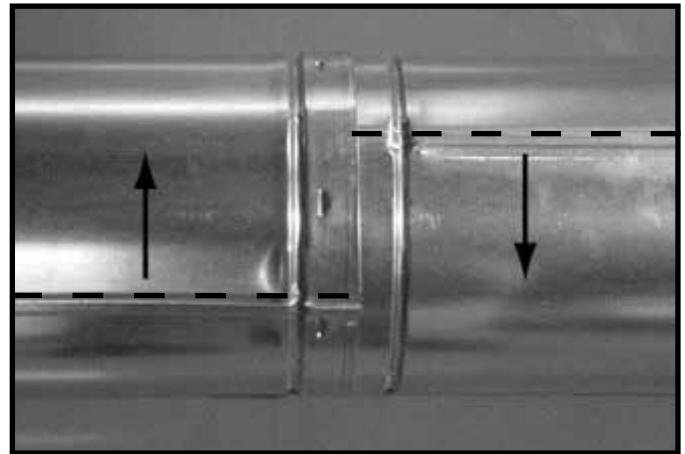

Figure 7.10 Rotate Seams for Disassembly

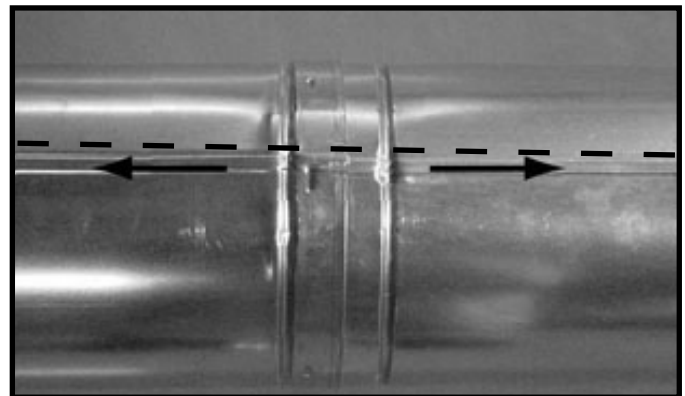

Figure 7.11 Align and Disassemble Vent Sections

E. Vertical Termination Requirements

Install Metal Roof Flashing

- See minimum vent heights for various pitched roofs (Figure 7.12) to determine the length of pipe to extend through the roof.
- Slide the roof flashing over the pipe sections extending through the roof as shown in Figure 7.13.

Note: When installing a silicone or EPDM pipe flashing boot on a metal roof, it is recommended to put a bead of 100% silicone sealant where the boot contacts the vent pipe to prevent the entry of water. Follow the manufacturer's recommendations when installing the boot.

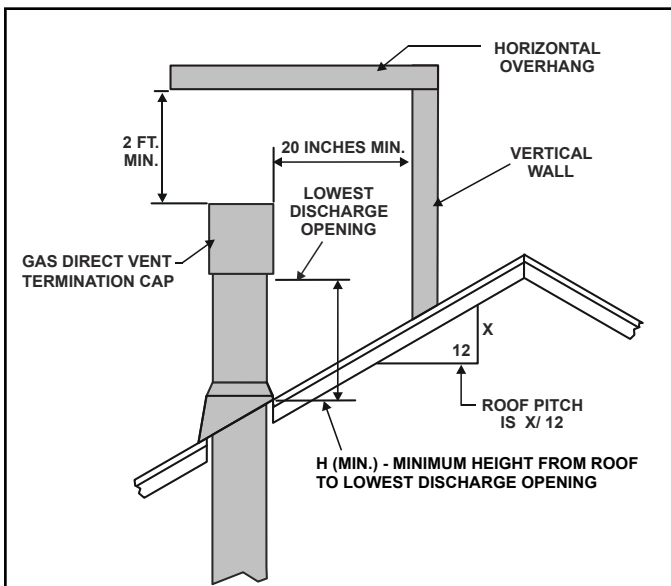

Roof Pitch	H (Min.) Ft.
Flat to 6/12.....	1.0*
Over 6/12 to 7/12.....	1.25*
Over 7/12 to 8/12.....	1.5*
Over 8/12 to 9/12.....	2.0*
Over 9/12 to 10/12.....	2.5*
Over 10/12 to 11/12.....	3.25
Over 11/12 to 12/12.....	4.0
Over 12/12 to 14/12.....	5.0
Over 14/12 to 16/12.....	6.0
Over 16/12 to 18/12.....	7.0
Over 18/12 to 20/12.....	7.5
Over 20/12 to 21/12.....	8.0

* H minimum may vary depending on regional snowfall. Refer to local codes.

Figure 7.12 Minimum Height From Roof to Lowest Discharge Opening

NOTICE: Failure to properly caulk the roof flashing and pipe seams could permit entry of water.

- Caulk the gap between the roof flashing and the outside diameter of the pipe.
- Caulk the perimeter of the flashing where it contacts the roof surface. See Figure 7.13.
- Caulk the overlap seam of any exposed pipe sections that are located above the roof line.

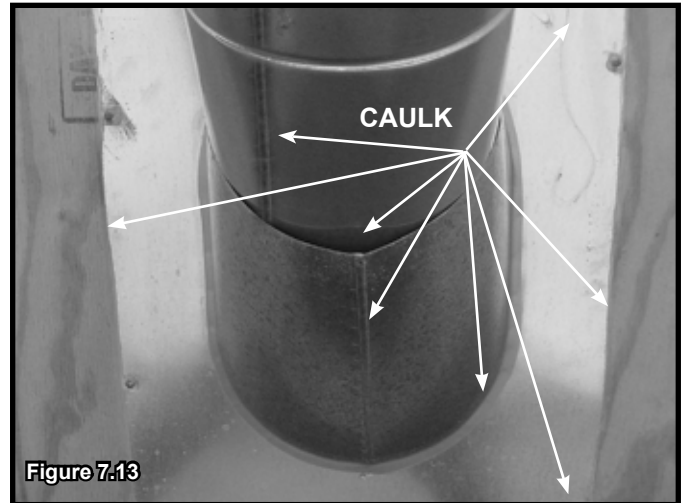

Figure 7.13

Assemble and Install Storm Collar

CAUTION! Risk of Cuts, Abrasions or Flying Debris. Wear protective gloves and safety glasses during installation. Sheet metal edges are sharp.

- Slide the storm collar onto the exposed pipe section and align brackets.
- Insert a bolt (provided) through the brackets and install nut. Do not completely tighten.



Figure 7.14 Insert Bolt into Brackets

- Slide the assembled storm collar down the pipe section until it rests on the roof flashing (see Figure 7.14).
- Tighten nut and make sure the collar is tight against the pipe section.
- Caulk around the top of the storm collar. See Figure 7.15.

Install Vertical Termination Cap

- Attach the vertical termination cap by sliding the inner collar of the cap into the inner flue of the pipe section while placing the outer collar of the cap over the outer flue of the pipe section.
- Secure the cap by driving three self-tapping screws (supplied) through the pilot holes in the outer collar of the cap into the outer flue of the pipe (see Figure 7.15).

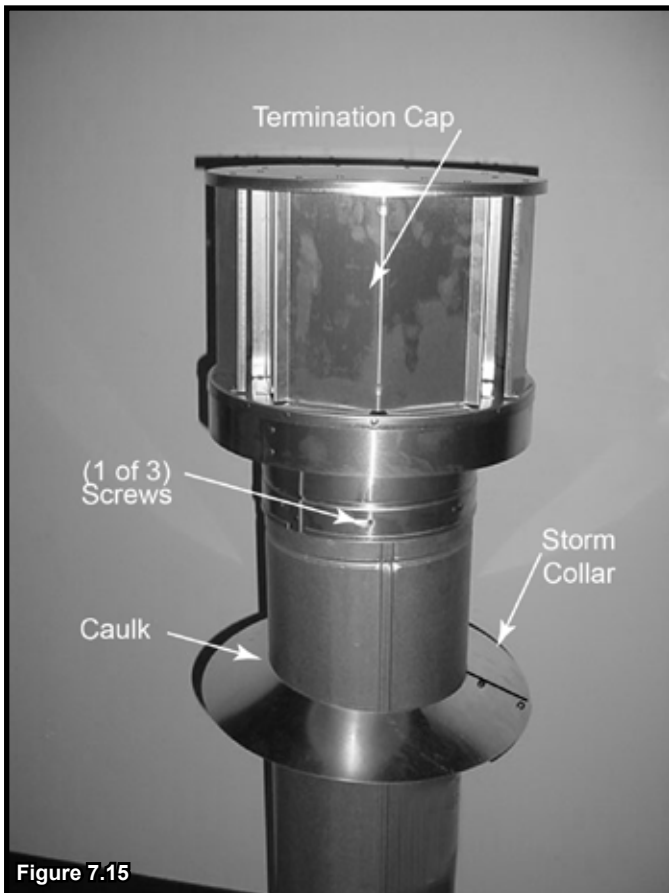

Figure 7.15

F. Horizontal Termination Requirements

Heat Shield Requirements for Horizontal Termination

WARNING! Risk of Fire! To prevent overheating and fire, heat shields must extend through the entire wall thickness.

- **DO NOT** remove the heat shields attached to the wall shield firestop and the horizontal termination cap (shown in Figure 7.16).
- Heat shields must overlap 1-1/2 in. (38 mm) minimum.

There are two sections of the heat shield. One section is factory-attached to the wall shield firestop. The other section is factory-attached to the cap. See Figure 7.16.

If the wall thickness does not allow the required 1-1/2 in. (38 mm) heat shield overlap when installed, an extended heat shield must be used.

- If the wall thickness is less than 4 in./102 mm, the heat shields on the cap and wall shield firestop must be trimmed. A minimum 1-1/2 in. (38 mm) overlap **MUST** be maintained.
- Use an extended heat shield if the finished wall thickness is greater than 7-1/4 in. (184 mm).
- The extended heat shield may need to be cut to length maintaining sufficient length for a 1-1/2 in. (38 mm) overlap between heat shields.
- Attach the extended heat shield to either of the existing heat shields using the screws supplied with the extended heat shield. Refer to vent components diagrams in the back of this manual.
- Rest the small leg on the extended heat shield on top of the pipe section to properly space it from the pipe section.

Important Notice: Heat shields may not be field constructed.

Install Horizontal Termination Cap

WARNING! Risk of Fire! The telescoping flue section of the termination cap **MUST** be used when connecting vent.

- 1-1/2 (38 mm) minimum overlap of flue telescoping section is required.

Failure to maintain overlap could cause overheating and fire.

- Vent termination must not be recessed in the wall. Siding may be brought to the edge of the cap base.
- Flash and seal as appropriate for siding material at outside edges of cap.
- When installing a horizontal termination cap, follow the cap location guidelines as prescribed by current **ANSI Z223.1** and **CAN/CGA-B149** installation codes and refer to Section 4 of this manual.

CAUTION! Risk of Burns! Local codes may require installation of a cap shield to prevent anything or anyone from touching the hot cap.

Note: When using termination caps with factory-supplied heat shield attached, no additional wall shield firestop is required on the exterior side of a combustible wall.

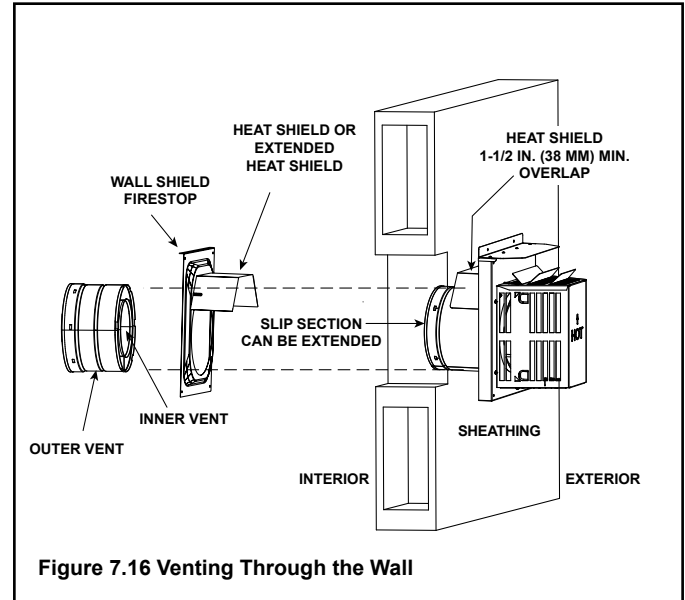

8 Electrical Information

A. General Information

WARNING! Risk of Shock or Explosion! DO NOT wire 110-120 VAC to the valve or to the appliance wall switch. Incorrect wiring will damage controls.

NOTICE: This appliance must be electrically wired and grounded in accordance with local codes or, in the absence of local codes, with **National Electric Code ANSI/NFPA 70-latest edition or the Canadian Electric Code CSA C22.1.**

- Wire the appliance junction box to unswitched 110-120 VAC. This is required for proper operation of the appliance (IntelliFire ignition).
- A 110-120 VAC circuit for this product must be protected with ground-fault circuit-interrupter protection, in compliance with the applicable electrical codes, when it is installed in locations such as in bathrooms or near sinks.
- Low voltage and 110-120 VAC voltage cannot be shared within the same wall box.

Junction Box Installation

- Pull the electrical wires from outside the appliance through the opening into the valve compartment and secure wires with a Romex connector. See Figure 8.1.
- Make all necessary wire connections to the junction box/receptacle and reattach the junction box/receptacle to the outer shell.

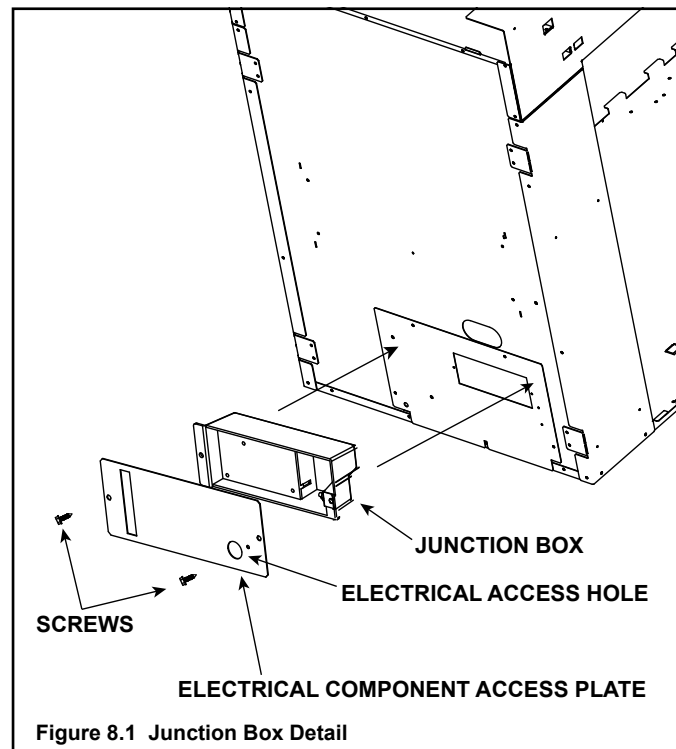

Accessories Requirements

- This appliance may be used with a wall switch or a remote control.

Wiring for optional Hearth & Home Technologies approved accessories should be done now to avoid reconstruction. Follow instructions that come with those accessories.

Electrical Service and Repair

WARNING! Risk of Shock! Label all wires prior to disconnection when servicing controls. Wiring errors could cause improper and dangerous operation. Verify proper operation after servicing.

WARNING! Risk of Shock! Replace damaged wire with type 105° C rated wire. Wire must have high temperature insulation.

B. IntelliFire Touch® Ignition System Wiring

- Wire the appliance junction box to 110-120 VAC for proper operation of the appliance.

WARNING! Risk of Shock or Explosion! DO NOT wire IPI controlled appliance junction box to a switched circuit. Incorrect wiring will override IPI safety lockout.

- Refer to Figure 8.2, IntelliFire Touch (IPI) Wiring Diagram.
- This appliance is equipped with an Intellifire® control valve which operates on a 6 volt system.

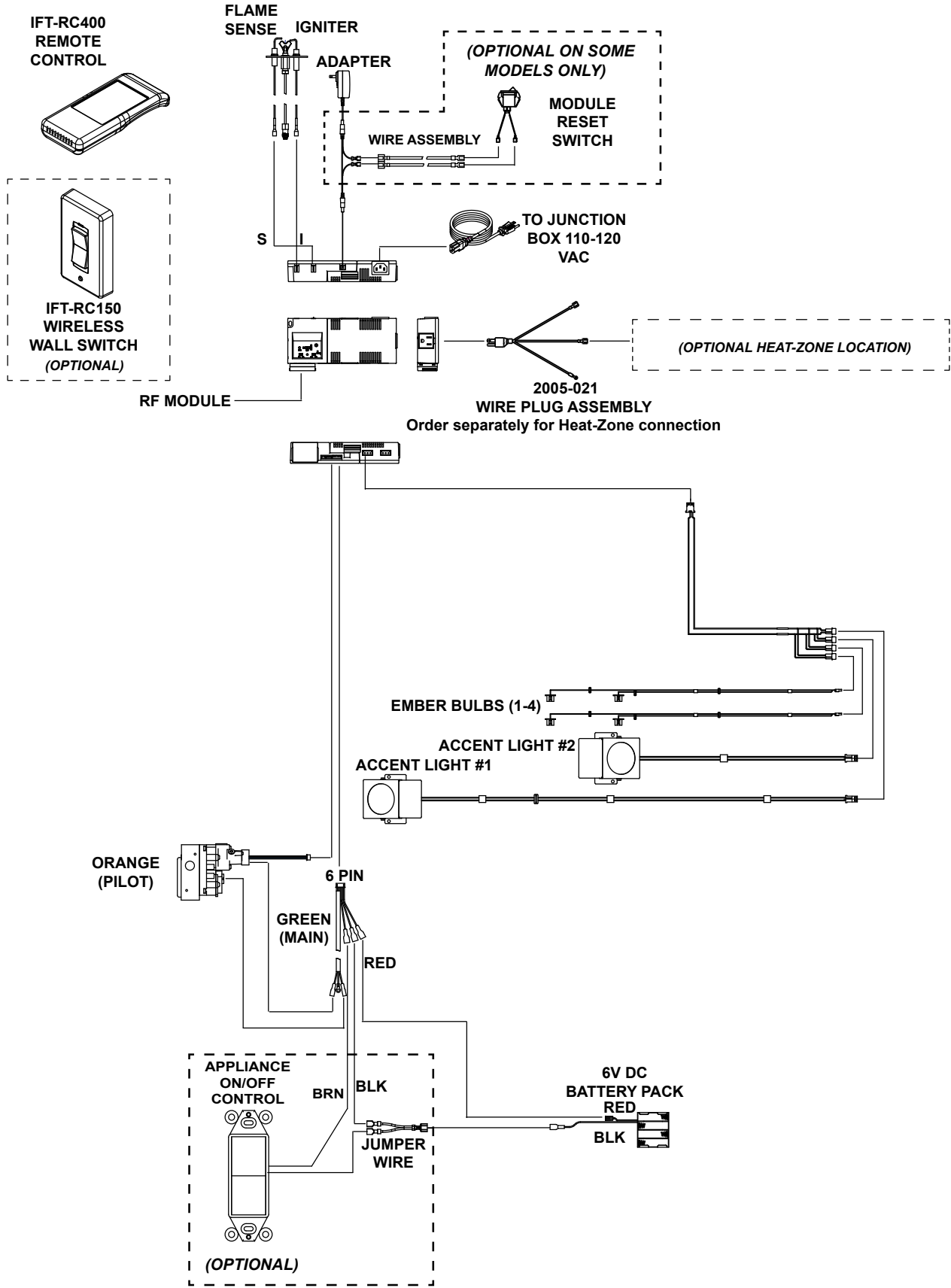



Figure 8.2 IntelliFire Touch Wiring Diagram

→ 9 Gas Information

⚠ WARNING



Risk of Fire! Risk of Explosion! Risk of Asphyxiation!

Follow all instructions and warnings for installing and servicing gas line.

- Gas line installation and service must be performed by a qualified installer or licensed plumber in accordance with all applicable codes for the installation location (NFPA 54 / ANSI Z223.1, the current International Fuel Gas Code, or CAN/CSA B149 in Canada) (In the Commonwealth of Massachusetts installation must be performed by a licensed plumber or gas fitter).
- Check all fittings and connections by means of a listed combustible gas detector, a noncorrosive leak detection fluid, or other approved leak detection method. **DO NOT** use open flame.



⚠ WARNING



Risk of Fire! Risk of Explosion!

Pressure exceeding 1/2 PSIG (14 in. w.c. / 3.5 kPa) will damage gas valve control.

- Disconnect appliance and its manual shutoff valve BEFORE line pressure testing.
- Cap outlet on piping system at appliance connection BEFORE line pressure testing.
- Connect appliance AFTER confirming piping system pressure is equal or less than 1/2 PSIG (14 in. w.c. / 3.5 kPa).



A. Fuel Conversion

- Make sure the appliance is compatible with available gas types.
- Conversions must be made by a qualified service technician using Hearth & Home Technologies specified and approved parts.

B. Gas Pressure

- Install pressure regulator upstream of gas valve if line inlet pressure exceeds 1/2 PSIG.
- Recommended inlet pressure for optimal appliance performance: 7.0 in. w.c. (NG) 12.0 in. w.c. (Propane)
- Pressure requirements when in operation are:

Gas Pressure	Natural Gas	Propane
Minimum inlet pressure	5.0 in. w.c.	11.0 in. w.c.
Maximum inlet pressure	10.0 in. w.c.	13.0 in. w.c.
Manifold pressure	3.5 in. w.c.	10.0 in. w.c.

- Verify inlet pressure is within specified range, including when other household gas appliances are operating.

Note: A listed (and Commonwealth of Massachusetts approved) 1/2 in. (13 mm) T-handle manual shut-off valve and flexible gas connector are connected to the 1/2 in. (13 mm) control valve inlet.

- If substituting for these components, please consult local codes for compliance.**

C. Gas Connection and Gas Line Purging

⚠ WARNING



Risk of Fire! Risk of Explosion!

Gas buildup during line connection and purging could ignite.

- Support gas control when attaching pipe to prevent bending gas line.
- Gas line installation and purging of the gas fuel line **MUST** be performed by a qualified service technician or a licensed plumber in accordance with the applicable gas code for the installation location (NFPA 54 / ANSI Z223.1, the current International Fuel Gas Code, or CAN/CSA B149 in Canada).
- Use a listed combustible gas detector, a noncorrosive leak detection fluid, or other approved leak detection method to check all fittings and connections for gas leaks before lighting the appliance.
- Ensure ventilation.
- Eliminate ignition sources, such as sparks or open flames.



- Refer to Section 3 for location of gas line access in appliance.
- Pipe incoming gas line into valve compartment.
- The gap between supply piping and gas access hole may be sealed with caulk or aluminum foil tape with a minimum of 300 °F continuous exposure rating or stuffed with non-combustible, unfaced insulation to prevent cold air infiltration.
- Ensure that gas line does not come in contact with outer wrap of the appliance. Follow local codes.
- Connect incoming gas line to the 1/2 in. (13 mm) NPT connection on manual shutoff valve.
- A small amount of air will be in the gas supply line and must be purged. Light the appliance to allow air to purge through the pilot assembly.

D. High Altitude Installations

NOTICE: If the heating value of the gas has been reduced, these rules do not apply. Check with your local gas utility or authorities having jurisdiction.

When installing above 2000 feet elevation:

- In the USA: Reduce input rate 4% for each 1000 feet above 2000 feet.
- In CANADA: Input ratings are certified without a reduction of input rate for elevations up to 4500 feet (1370 m) above sea level. Please consult provincial and/or local authorities having jurisdiction for installations at elevations above 4500 feet (1370 m).

Check with your local gas utility to determine proper orifice size.

E. Air Shutter Setting

Air shutter settings should be adjusted by a qualified service technician at the time of installation. The shutter adjustment rod is located adjacent to the gas valve. The shutter setting is preset at the factory for either NG or propane. These are tested settings that work well for most venting applications. Units with increased vertical venting may require a shutter setting that is more closed. Installations with extended horizontal venting may require a more open shutter setting. The measurement is taken from the face of the appliance to the end of the silicone cap. See Figure 9.1.

- Push the air handle in to close the air shutter.
- Pull the air handle out to open the air shutter.

NOTICE: If sooting occurs, provide more air by opening the air shutter.

Air Shutter Settings

	NG	PROPANE
ESC-42ST-IFT	1-1/2 in.	Fully Open

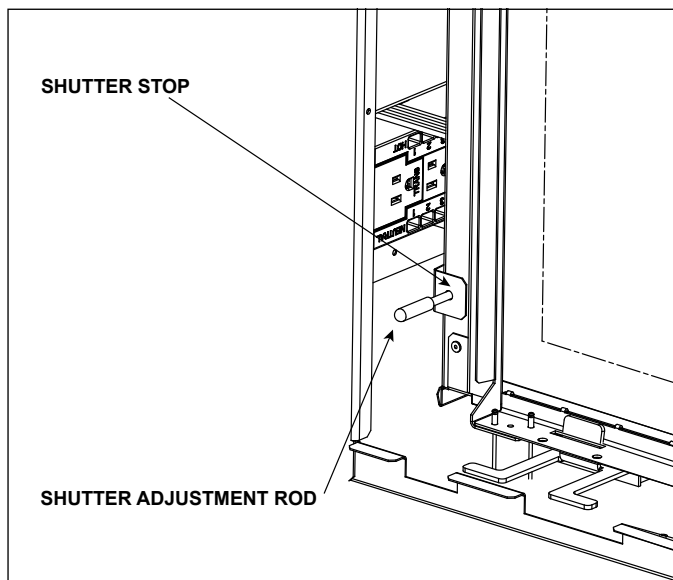

Figure 9.1 Shutter Adjustment Rod and Shutter Stop

F. Service/Replace Appliance Gas Valve

- See Figure 9.2.
- Remove decorative barrier front, outer refractory and glass assembly.
- Perform service or replace gas valve.
- Reinstall glass assembly, outer refractory and decorative barrier front.

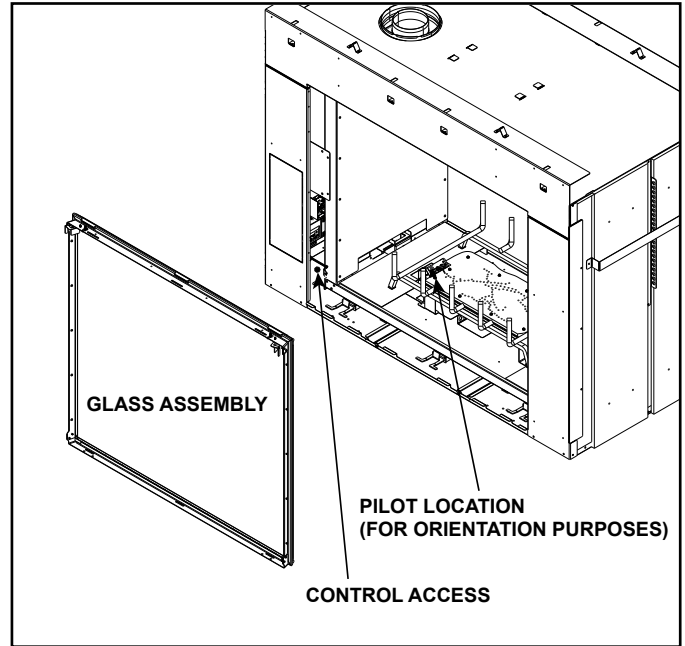

Figure 9.2 Gas Valve Access

10 Finishing

A. Facing Material

- Metal front faces may be covered with non-combustible materials only.
- Facing and/or finishing materials must not interfere with air flow through louvers, operation of louvers or doors, or access for service.
- Facing and/or finishing materials must never overhang into the glass opening.
- Observe all clearances when applying combustible materials.

WARNING! Risk of Fire! DO NOT apply combustible materials beyond the minimum clearances. Comply with all minimum clearances to combustibles as specified in this manual. Overlapping materials could ignite and will interfere with proper operation of decorative fronts and louvers.

NOTICE: Surface temperatures around the appliance will become warm while the appliance is in operation. Ensure finishing materials used for all surfaces (floor, walls, mantels, etc.) will withstand temperatures up to 190°F.

If using vinyl flooring, refer to Section 3.E.

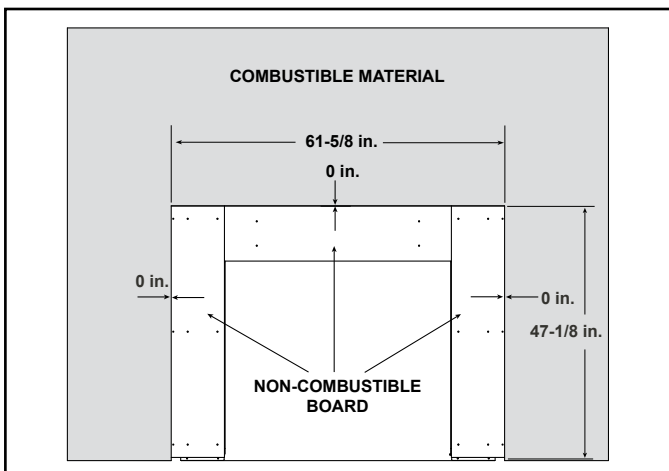

Figure 10.1 Noncombustible Facing Diagram

B. Mantel and Wall Projections

WARNING! Risk of Fire! Comply with all minimum clearances as specified. Framing closer than the minimums listed must be constructed entirely of non-combustible materials (i.e., steel studs, concrete board, etc.).

Combustible Mantels

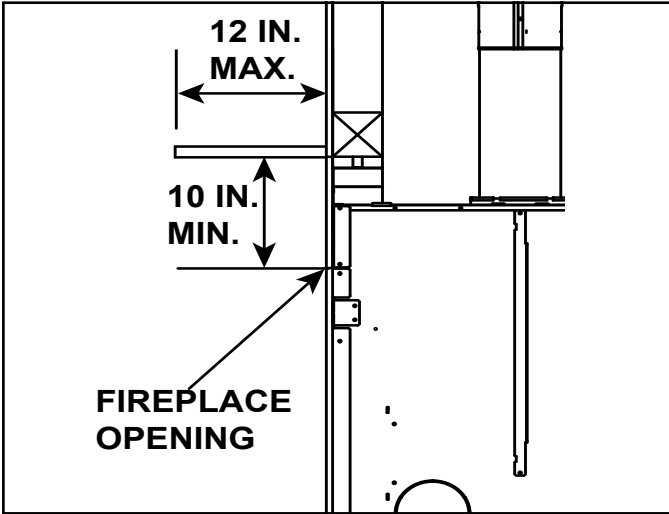

Figure 10.2 Clearances to Mantels or Other Combustibles Above Appliance

Non-combustible Mantels

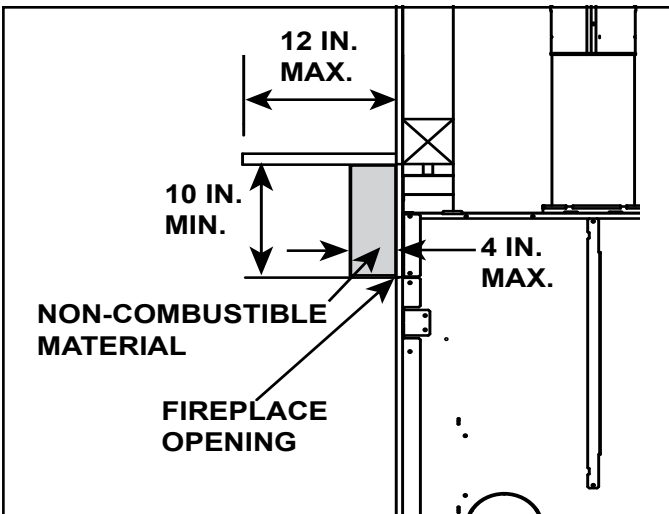

Figure 10.3 Clearances to Mantels or other Non-Combustibles Above Appliance

Combustible Mantel Legs or Wall Projections

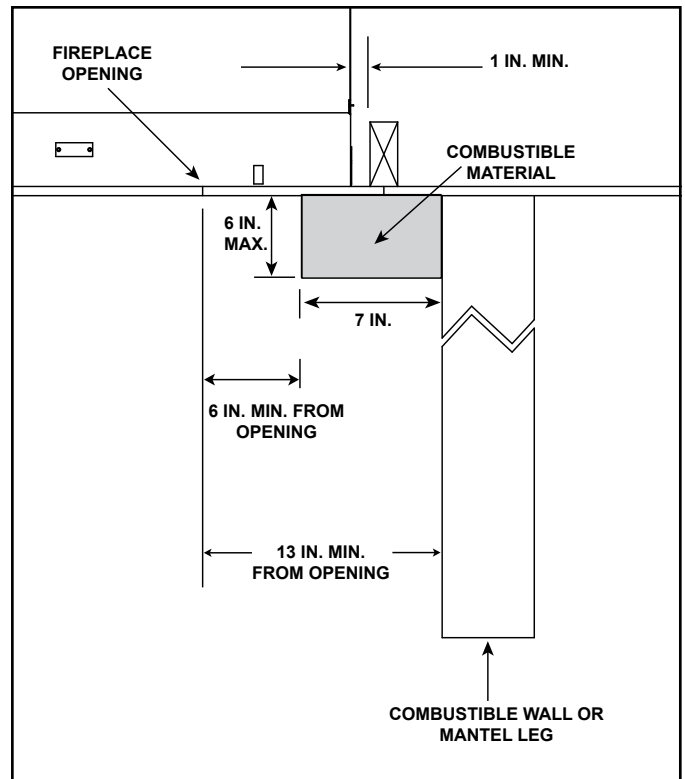

Figure 10.4 Clearances to Combustible Mantel Legs or Wall Projections.

Non-Combustible Mantel Legs or Wall Projections

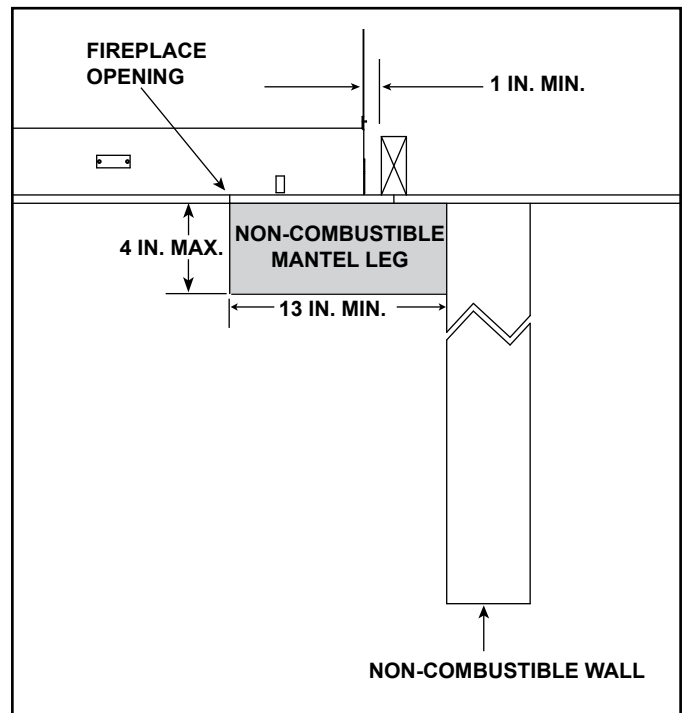

Figure 10.5 Clearances to Non-Combustible Mantel Legs or Wall Projections.

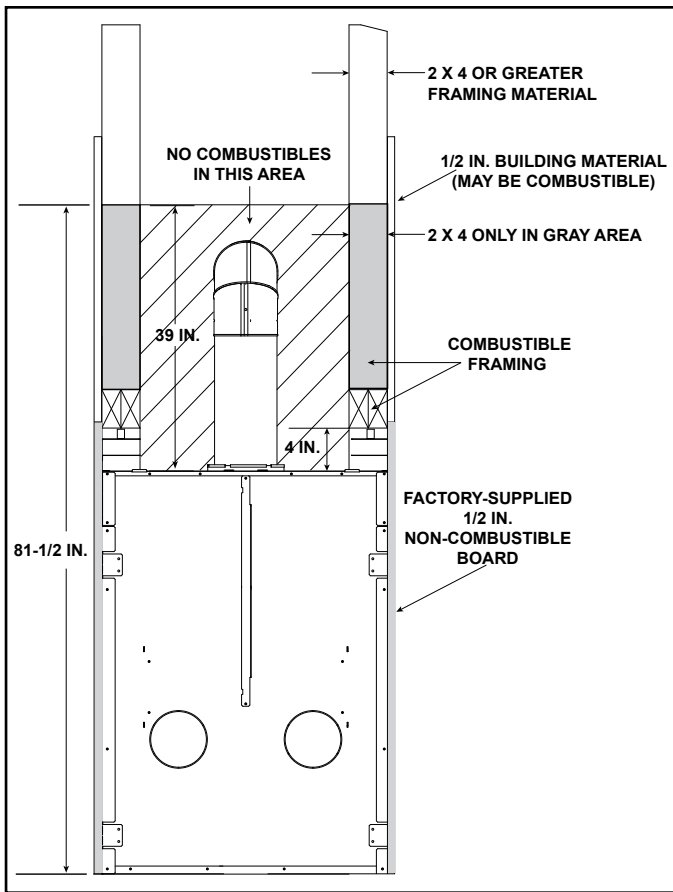

Figure 10.6

C. Decorative Fronts

Only decorative fronts certified for use with this appliance model may be used. Contact your dealer for a list of decorative fronts that may be used. Once you have determined what kind of decorative front and finishing material is going to be used on the fireplace, you may use the table below which shows the decorative front models and the finishing material thickness allowed.

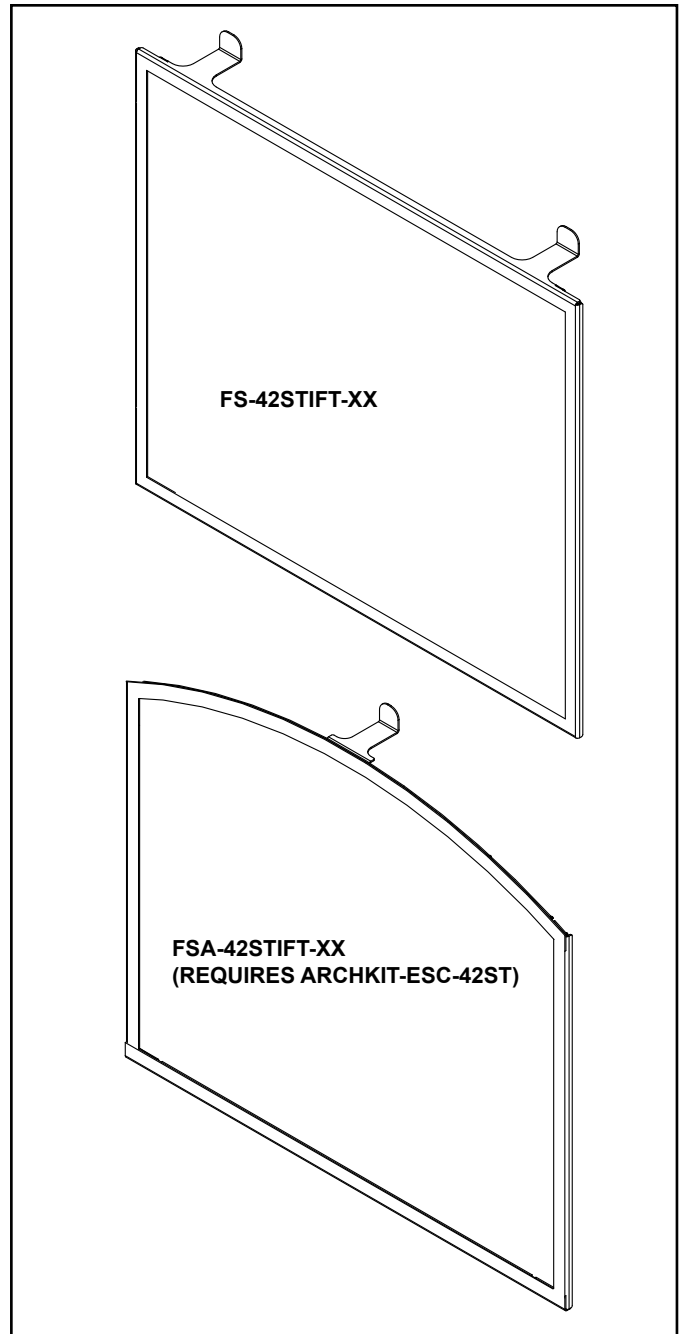

Figure 10.7 Approved Decorative Fronts for ESC-42ST-IFT

Note: Firescreen sits out 1-1/2 inches from the face of the fireplace. When using thin finishing material, you may want to use thicker non-combustible backer board to bring the finishing material flush with the firescreen. This is not required.

11 Appliance Setup

A. Fixed Glass Assembly

WARNING! Risk of Asphyxiation! Glass installation and removal should be performed only by a qualified service technician. Handle fixed glass assembly with care. Inspect the gasket to ensure it is undamaged and inspect the glass for cracks, chips or scratches.

- **DO NOT** strike, slam or scratch glass.
- **DO NOT** operate fireplace with glass removed, cracked, broken or scratched.
- Replace as a complete assembly.

Installing Fixed Glass Assembly

1. Identify the top and bottom of the glass assembly. The top of the glass frame has three engagement grooves. The engagement groove is highlighted in Figure 11.1.

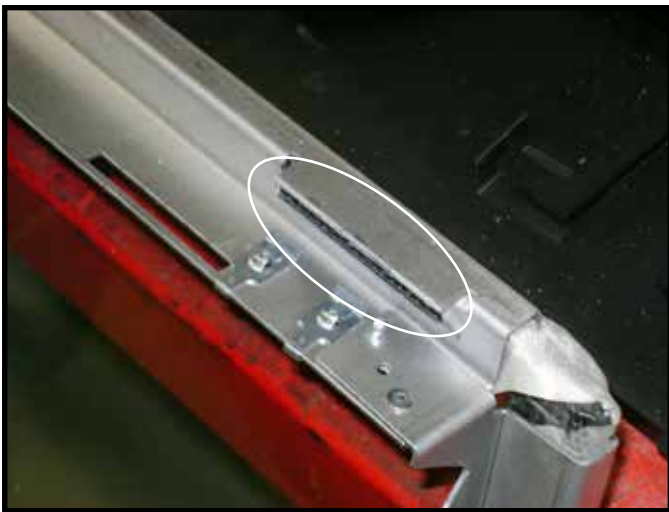

Figure 11.1 Glass Top Tab Detail.

2. Start by tipping the top of the glass frame toward the fireplace. Center the glass between the left and right firebox supports. Push “up” and “in” and set the glass assembly on the bottom three glass latch tabs. See Figure 11.2 .



Figure 11.2 Initial Positioning of Frame into Opening.

3. With the glass assembly resting (not engaged) on the bottom glass latch tabs, allow for the top of the glass assembly to tip away from the fireplace. Lift up slightly and ensure the glass assembly bottom seal is tight to the bottom of the firebox. See Figure 11.3.



Figure 11.3 Second Position of Frame into Opening.

4. Engage the bottom glass latch tabs into the three slots in the bottom of the glass frame.

To engage the tabs into the frame slots, manipulate the glass clips by pulling out the glass latch handles. Figure 11.3 shows the middle glass latch tab engaged.

Engage an end latch first, then middle latch, and finally the last end latches.

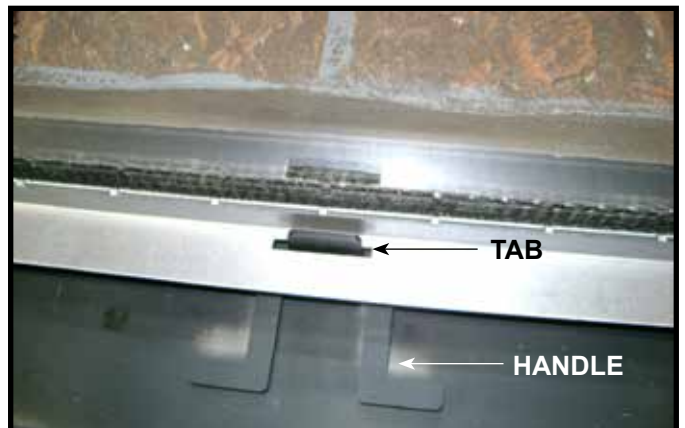

Figure 11.4 Glass Latch Engaged into Frame Latch.

5. Ensure all three bottom glass latch tabs are engaged and centered in the three slots in the glass frame. The glass latch tab should protrude through the slot in the glass frame about 1/4 in. See Figure 11.5



Figure 11.5 Bottom Glass Latch Tabs Installed in Glass Frame

6. Engage the three glass latches on top. Push the top of the glass toward the fireplace. Use index fingers to manipulate top glass latches and pull out and latch the three glass assembly latches into the engagement grooves. See Figure 11.6 and Figure 11.7.



Figure 11.6 Top Glass Latch Access

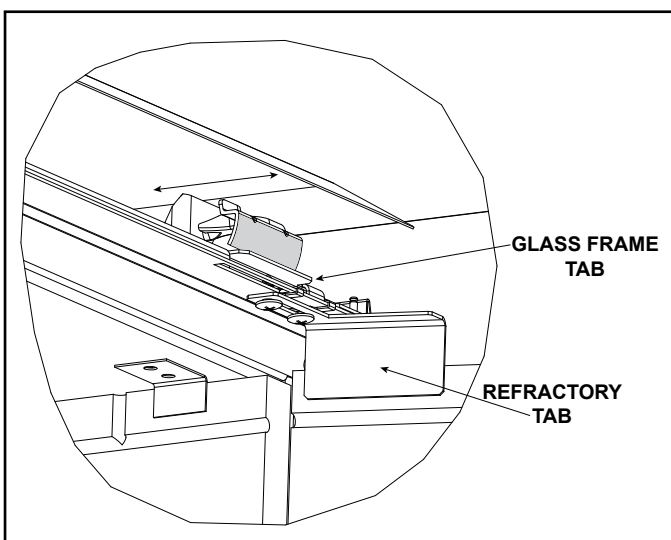

Figure 11.7. Top Glass Latch Detail

Removing Fixed Glass Assembly

- Remove glass assembly by reversing these glass installation instructions.

B. Remove the Shipping Materials

Remove shipping materials from inside or underneath the firebox.

- The splatter guard is a piece of corrugated material used to protect the appliance during the installation process before finishing work on the whole hearth is complete. Splatter guards may be factory installed or accompany the decorative front of the appliance, depending on the fireplace model. Splatter guards must be removed before appliance is fired.

WARNING! Risk of Fire! Close the ball valve before installing the splatter guard to prevent accidental lighting. Remove the splatter guard before lighting the appliance.

C. Clean the Appliance

Clean/vacuum any sawdust that may have accumulated inside the firebox or underneath in the control cavity.

D. Accessories

Install approved accessories per instructions included with accessories. Contact your dealer for a list of approved accessories.

WARNING! Risk of Fire and Electric Shock! Use ONLY Hearth & Home Technologies-approved optional accessories with this appliance. Using non-listed accessories could result in a safety hazard and will void the warranty.

E. Installing the Optional Heat-Zone® Gas Kit

1. Remove one of the knockouts from the side of the appliance and discard it. See Figure 11.8.
2. Center the duct collar around the exposed hole and attach it to the appliance with 3 screws. **Note:** Do this **BEFORE** final positioning of the appliance.
3. Determine the location for the air register/fan housing assembly.

Reference the Heat-Zone® Gas Kit instructions for the remaining installations steps.

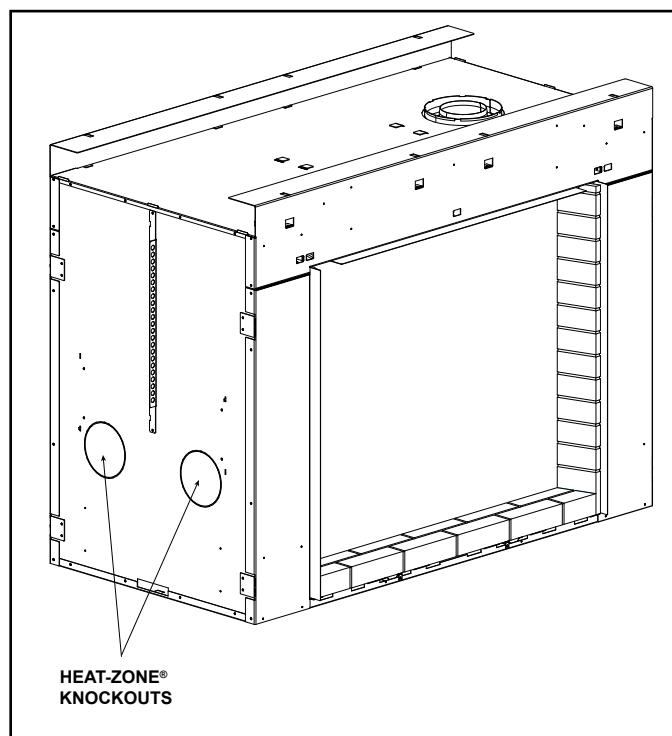

Figure 11.8 Heat-Zone® Gas Knockouts.

F. Install Light Bulbs

Note: Light bulbs are shipped in the installation manual bag.

Ember Lights

1. Remove ember basket by lifting it from fireplace. There is one metal tab on each end of the ember box that engages slots in the ember basket. See Figure 11.9.

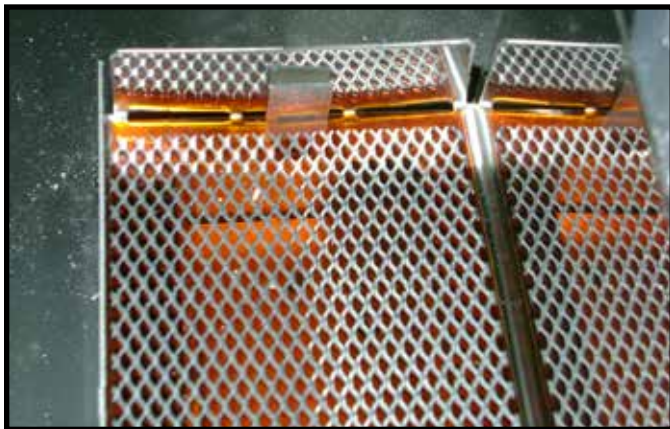

Figure 11.9 Ember Basket

2. Install two 20 watt halogen bulbs per side. See Figure 11.10.

NOTICE: Grip bulb by the porcelain base only. DO NOT TOUCH glass bulb. Touching the bulbs with fingers will greatly reduce the operating life of these bulbs.



Figure 11.10 Ember Light Bulb Installed

3. Reinstall ember basket over the ember box by inserting the tabs on the ember box in the slots on the ember basket. See Figure 11.9.

Accent Lights

1. Remove the screw that secures the two bottom sheet metal refractory standoffs which are installed around the left and right accent light assemblies. See Figure 11.14.
2. Install the two accent lights by either removing the two screws that hold the light housing to the firebox bottom as shown in Figure 11.13 or, for easy access, remove the two screws from the light housing cover. See Figure 11.1 Install bulb by inserting the 2 pins on the bulb base into the 2 holes in the socket. See Figure 11.12 or Figure 11.13.
3. Reassemble accent light housing. See Figure 11.14.
4. Reinstall the two bottom sheet metal refractory standoffs with one screw each. See Figure 11.14.

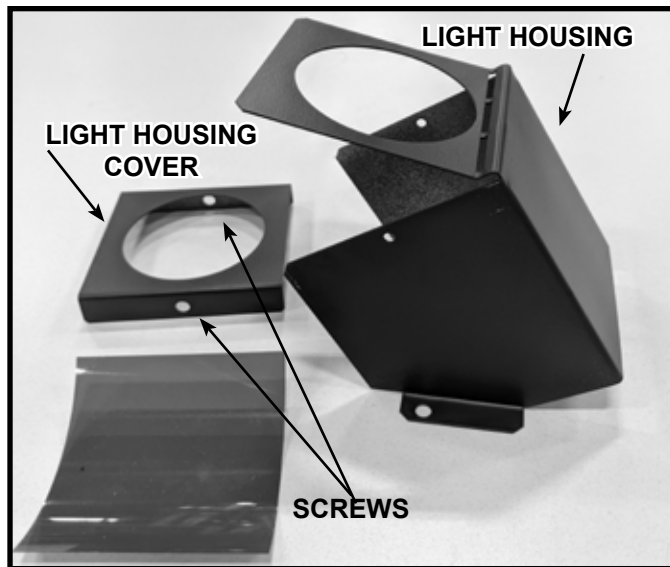

Figure 11.11 Light Housing Assembly

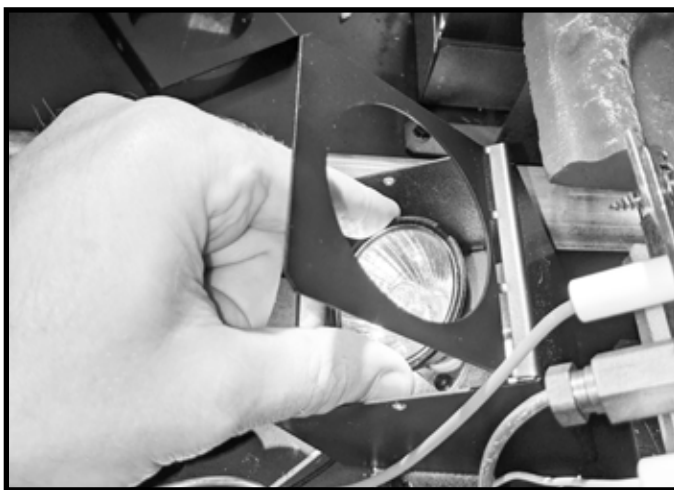

Figure 11.12 Install Bulb

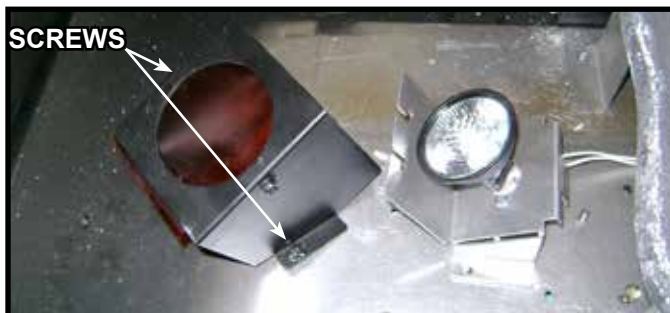

Figure 11.13 Light Housing Removed, Bulb Installed

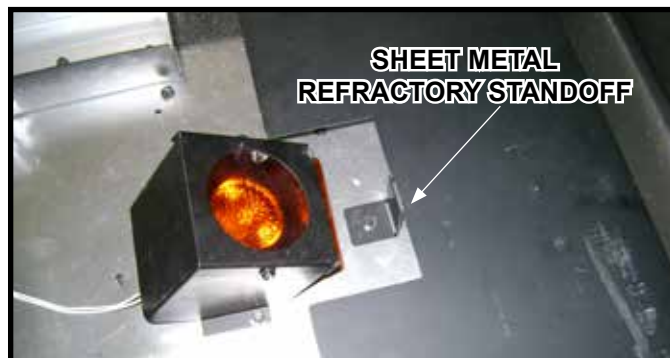

Figure 11.14 Accent Light Bulb Installation Completed

G. Install Refractory

CAUTION: Refractory pieces are fragile! Carefully remove the refractory pieces from the packaging.

1. Side refractory panels are held in place by either four pre-installed clips or four hand bend refractory retainers formed from the top heat shield. Install side refractory with the notched end of the refractory on the bottom. See Figure 11.15 and Figure 11.16. Ensure that side refractory panels are centered left to right and do not extend past the outer firebox flange. Either secure refractory with refractory clip and screw, or bend down hand bend feature from the top heat shield.



Figure 11.15 Notched End of Side Refractory

2. Install the left and right refractory middle base refractory pieces on top of the left and right bottom refractory standoffs. See Figure 11.17 and 11.18. Position so that the edge is flush with the ember light housing.



Figure 11.16 Refractory Clip Installation



Figure 11.17 Positioning Inner Bottom Refractory



Figure 11.18 Positioning Left and Right Middle Base Refractory



Figure 11.19 Positioning Outer Bottom Refractory.

5. Install two outer bottom refractory pieces as shown in Figure 11.19. Ensure that outer bottom refractory pieces do not extend past the outer firebox flange.

H. Install Teco-Sil (Glass Ember Rock)

1. Install the glass ember rock (Teco-Sil) that is shipped with this fireplace into the left and right ember light trays. See Figure 11.20.



Figure 11.20 Glass Ember Bed

2. Using TUP-GBK-12 spray paint, dust the glass ember rock to create a more natural looking ash bed. Care should be taken to avoid overspray onto refractory, stainless steel back plate, or pilot. See Figure 11.21 and Figure 11.22.



Figure 11.21 Ember Bed Painting



Figure 11.22 Finished Ember Bed

I. Mystic Ember Placement

WARNING! Risk of Explosion! Follow ember placement instructions in manual. **DO NOT** place embers directly over burner ports. Replace ember material annually. Improperly placed embers interfere with proper burner operation.

Ember material is shipped with this gas appliance. Use this material to give the appliance a realistic ash bed. To place the ember material:

1. Place Mystic Embers in a random pattern around the base refractory away from port holes as shown in Figure 11.23.
2. Save the remaining ember materials for use during appliance servicing. The embers provided should be enough for 3 to 5 applications.



Figure 11.23 Ember Placement on Base Refractory

J. Install Logs

Log Set Assembly: LOGS-ESC42ST For Models: ESC-42ST, ESC-42ST-IFT

LOG PLACEMENT INSTRUCTIONS

CAUTION: Logs are fragile! Carefully remove the logs from the packaging.



Figure 1.



Figure 2.



Figure 3.

GRATE: Locate the pilot assembly. The pilot assembly is denoted in this instruction by a black or white arrow (→) on each photo. For the purpose of placing logs according to this instruction, begin with the pilot on the left side. Position grate by locating the four indentations on the bottom refractory. Place grate legs in the indentations as shown in Figure 3.



Figure 4.



Figure 5. Reverse View

LOG NUMBER 1 (SRV2146-701): Locate the pilot assembly. It should be on the left side of the fireplace. Place log #1 onto the grate and pull forward so that the indentation on the front of the log engages the left grate tine. The "burnt" tip of Log #1 should rest on the burner. The log must **NOT** block any burner ports. See Figure 4.



Figure 6.

Figure 7. Reverse View

LOG NUMBER 2 (SRV2146-702): Place Log #2 as shown. The groove on the bottom of Log #2 engages with the grate bar. Pull log forward so it engages the far right grate tine as shown in Figure 6. The “burnt” end of the log rests on the burner. The log must **NOT** block any burner ports.

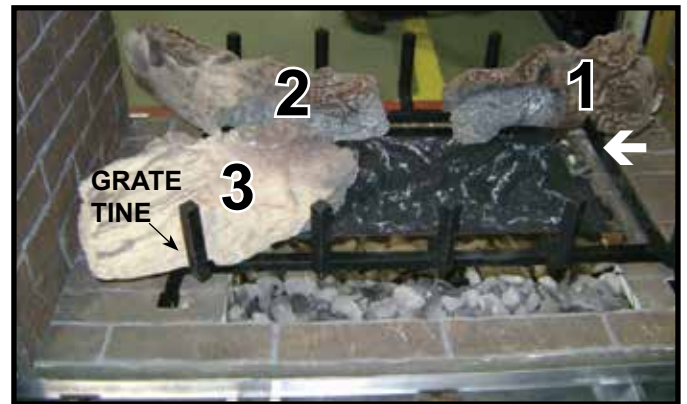

Figure 8.

Figure 9. Reverse View

LOG NUMBER 3 (SRV2146-703): Place Log #3 so that groove on bottom of log engages the grate bar. Push log back so that it rests against grate tine as shown in Figure 9. The “burnt” end of the log rests on the burner. The log must **NOT** block any burner ports.

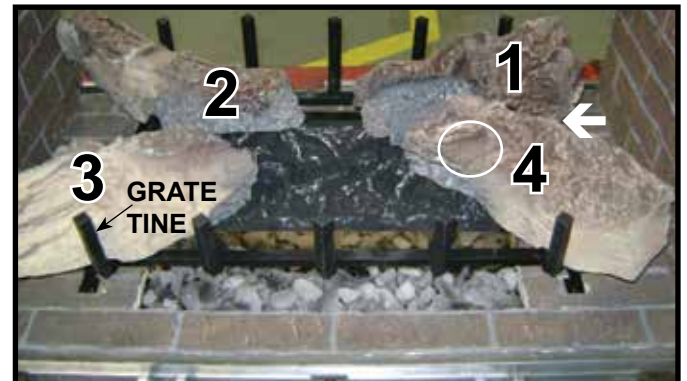
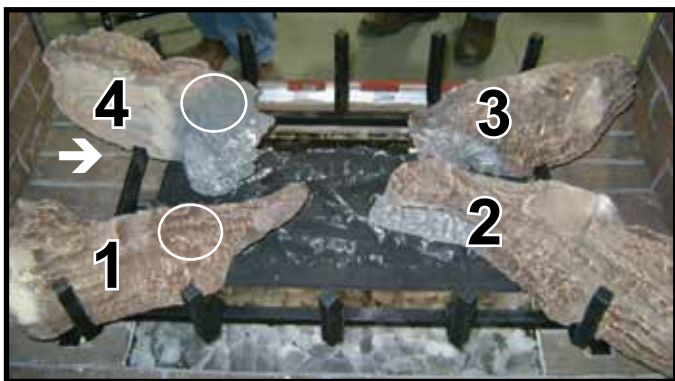

Figure 10.

Figure 11. Reverse View

LOG NUMBER 4 (SRV2146-704): Place Log #4 so that the groove on bottom of log rests on the grate bar as show in Figure 10. Push log so that it rests against the grate tine shown in Figure 11. The “burnt” end of the log rests on the burner. The log must **NOT** block any burner ports.

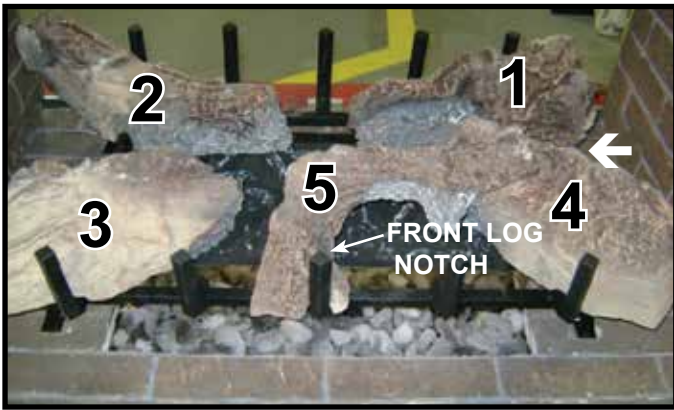

Figure 12.

LOG NUMBER 5 (SRV2146-705): Place Log #5 from side of unit where pilot is located on your right side. Place log so the front log notch engages the center grate tine as shown in Figure 12 and the right side of log rests on the notch in Log #4. See Figure 11. The notch is visible in Figure 11. The log must **NOT** block or sit directly over any burner ports.

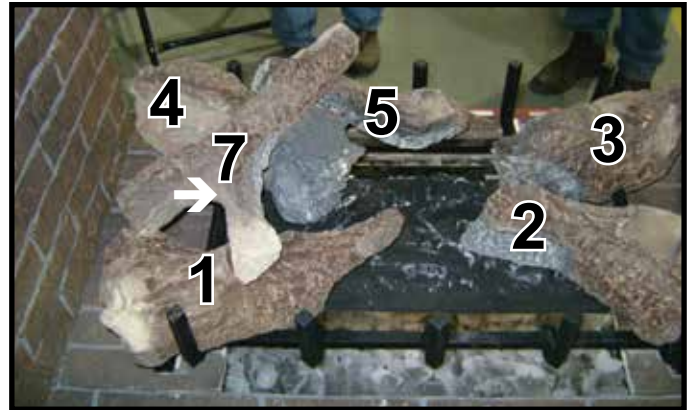

Figure 13.

LOG NUMBER 7 (SRV2146-707): Log #7 rests on the notch on top of log #1 and the notch on top of log #4. See Figure 13. The points of contact on Log #1 and Log #4 where Log #7 rests are indicated by the circles in Figure 10.

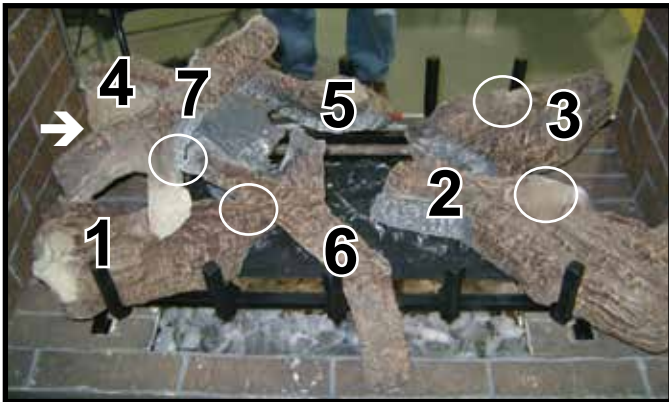

Figure 14.

LOG NUMBER 6 (SRV2146-706): Place Log #6 onto grate and log #1. The groove on the bottom of the log will engage the center grate bar and the other end of the log will rest on Log #1, with the tip touching Log #7. The points of contact are indicated by the circles located on Log #6 and Log #7 in Figure 14. The log must **NOT** block or sit directly over any burner ports.

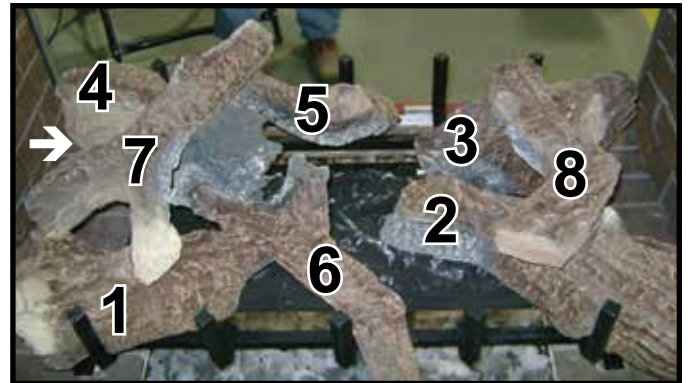

Figure 15.

LOG NUMBER 8 (SRV2146-708): Locate notch on Log #2 and notch on Log #3 indicated by the circles on Figure 14. Place Log #8 so that it rests in these notches. See Figure 15.

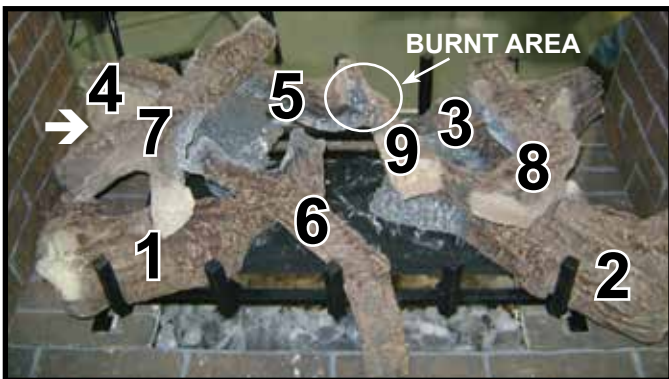

Figure 16.

LOG NUMBER 9 (SRV582-707): Place log #9 onto Log #2 and Log #5. The "burnt area" of log 9 will face the pilot side of the log assembly.

K. Ember/Mineral Wool Placement

WARNING! Risk of Explosion! DO NOT place embers directly over burner ports. Improperly placed embers interfere with proper burner operation. See instructions.

Ember material is shipped with this gas appliance. To place the ember material:

- Place dime-size pieces of Glowing Embers® just in front of the port trail, but not on or in between the ports. See Figure 11.24. Embers are to be placed adjacent to burner port holes. Care should be taken so that the ports are not covered. Failure to follow this procedure will likely cause lighting and sooting problems.
- Embers CANNOT be placed directly over ports. Care should be taken not to cover the lighting trail of ports (from back to front).

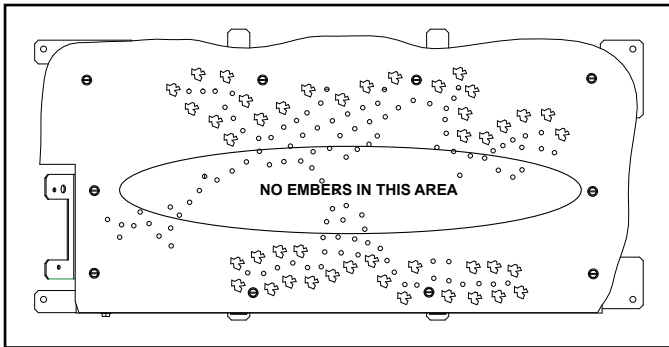

Figure 11.24 Ember Placement

L. IntelliFire Touch® Control System Setup

- Detailed instructions for electrical wiring and connections are provided in Section 8.
- Determine if this appliance is equipped with a Module Reset Switch. See Section 8. Verify this switch is in the ON position.
- Verify that the 3-Position switch on the IFT-ECM is switched to the REMOTE position. Detailed Operating Instructions for the IFT-ECM are provided in Section 3.J of the Owner's Manual.

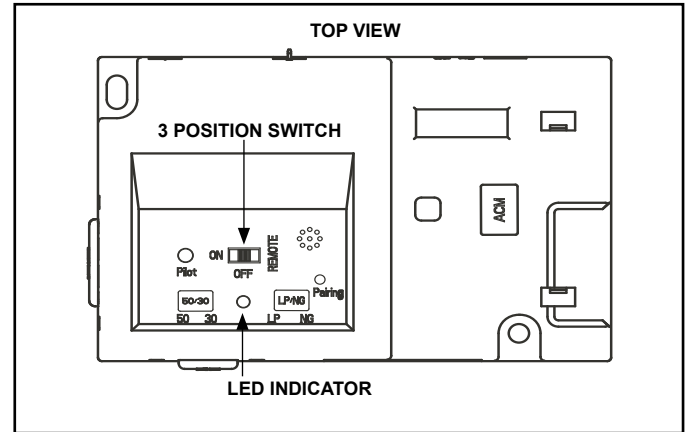

Figure 11.25 IFT-ECM

This appliance is factory-equipped with an IntelliFire Touch remote control. The remote was paired to the fire-place and tested at the factory. It does not need to be paired again, unless an accessory kit will be added at the time of installation. If no additional accessory will be added, simply follow steps one through seven below.

1. If installed, remove batteries from remote.
2. Verify that the new appliance has power and secure electrical connections.
3. Adjust the ECM selector switch to 'REMOTE' mode.
4. Switch the master reset switch to 'ON' (if equipped).
5. Wait to verify LED indicator on the ECM stops flashing.
6. Install batteries in the RC400 remote.
7. The RC400 remote will automatically pair to the appliance as pre-set at the factory.

M. Install Outer Refractory Panels

1. Install glass assembly. Refer to Section 11.A for glass installation.
2. The refractory brackets are shipped with an extra screw to secure placement during shipping. See Figure 11.26. Remove the indicated screws to allow adjustment of the refractory brackets. See Figure 11.27.
3. Install both outer refractory side panels and install refractory bracket to secure refractory panels in place. See Figure 11.27.
4. Install outer hearth. See Figure 11.28.
5. Repeat outer refractory panel instructions for opposite side.



Figure 11.26 Shipping Location of Refractory Brackets



Figure 11.27 Side Refractory Brackets



Figure 11.28 Outer Hearth Installation

N. Install Trim and/or Surround

- Install optional trim kits and/or surrounds using the instructions included with the accessory.
- Use non-combustible materials to cover the gap between the sheet rock and the appliance (if desired).

12 Reference Materials

A. Vent Components Diagrams

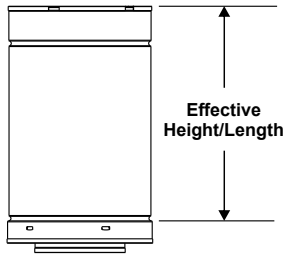

DVP Pipe (see chart)

Pipe	Effective Length	
	Inches	Millimeters
DVP4	4	102
DVP6	6	152
DVP12	12	305
DVP24	24	610
DVP36	36	914
DVP48	48	1219
DVP6A	3 to 6	76 to 152
DVP12A	3 to 12	76 to 305

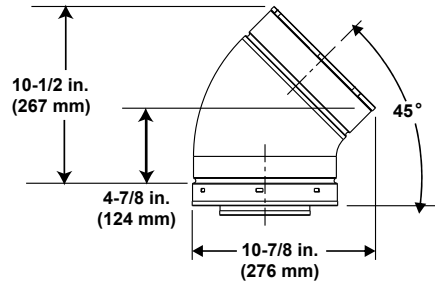

DVP45 (45° Elbow)

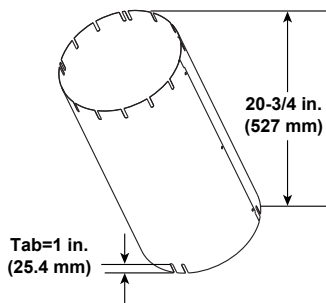

Finished Height: 19-3/4 in./502 mm
UNIV-AS2 (Attic Insulation Shield)

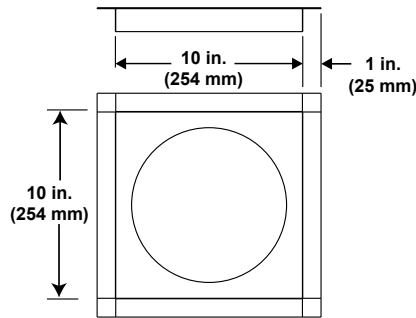

DVP-FS (Ceiling Firestop)

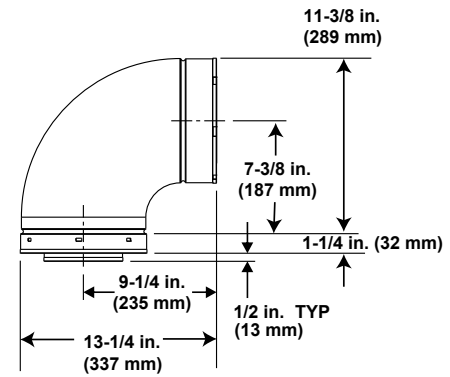

DVP90ST (90° Elbow)

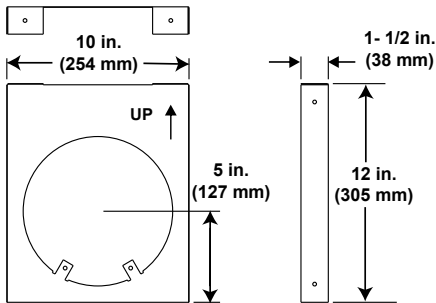

DVP-HVS (Vent Support)

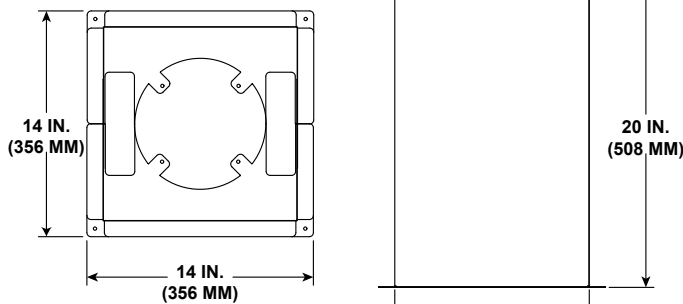

DVP-RDS
ROOF DECK INSULATION SHIELD

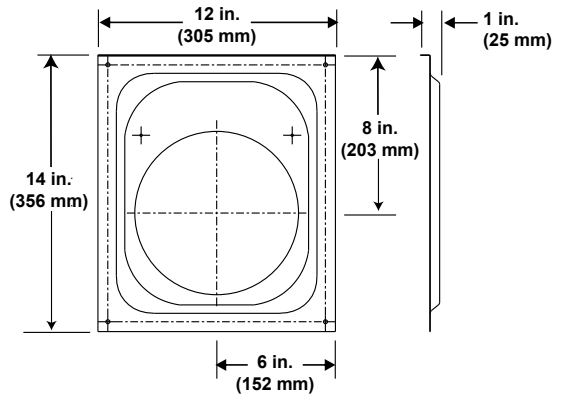

DVP-WS (Wall Shield Firestop)

Figure 12.1 DVP Vent Components

A. Vent Components Diagrams (continued)

Note: Heat shields MUST overlap by a minimum of 1-1/2 in. (38 mm). **The heat shield is designed to be used on a wall 4 in. to 7-1/4 in. (102 mm to 184 mm) thick.** If wall thickness is less than 4 in. (102 mm) the existing heat shields must be field trimmed. If wall thickness is greater than 7-1/4 in. (184 mm) a DVP-HSM-B will be required.

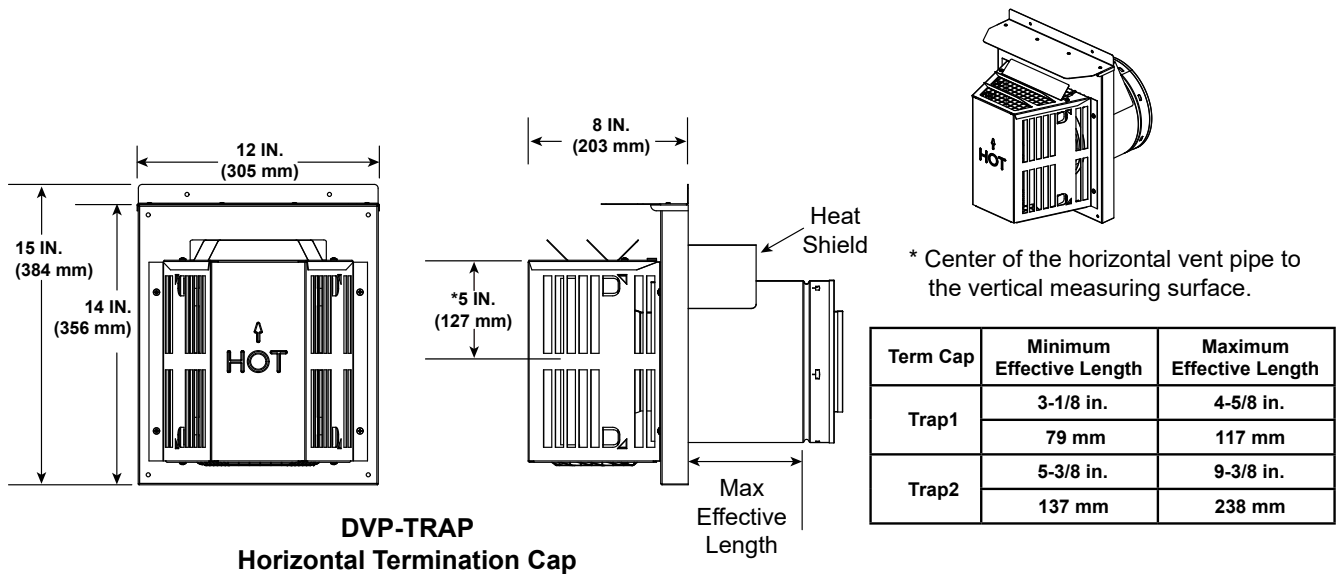

DVP-TRAP
Horizontal Termination Cap

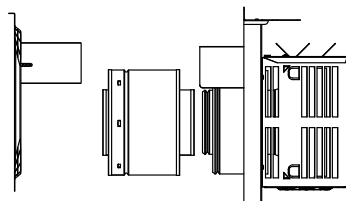

DVP-TRAP1

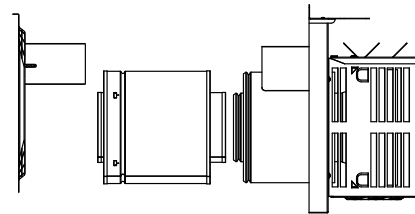

DVP-TRAP2

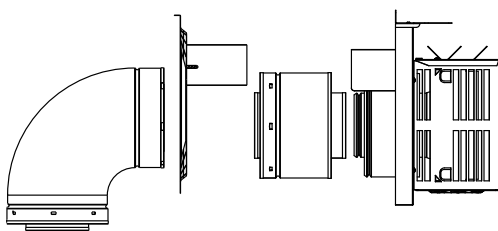

DVP-TRAPK1

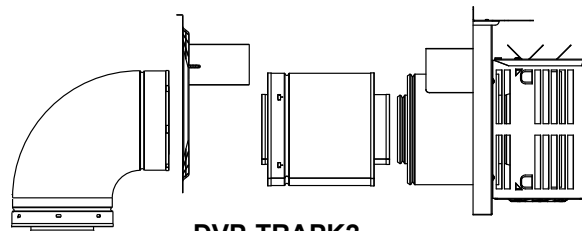

DVP-TRAPK2

Figure 12.2 DVP Vent Components

A. Vent Components Diagrams (continued)

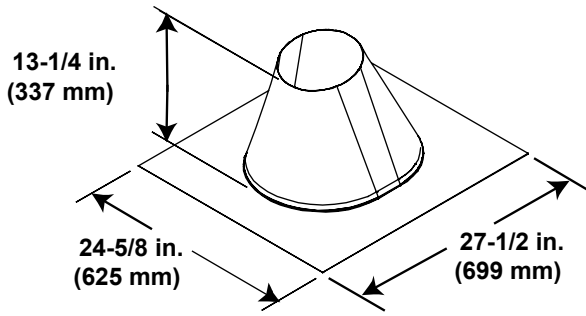

RF6
Roof Flashing

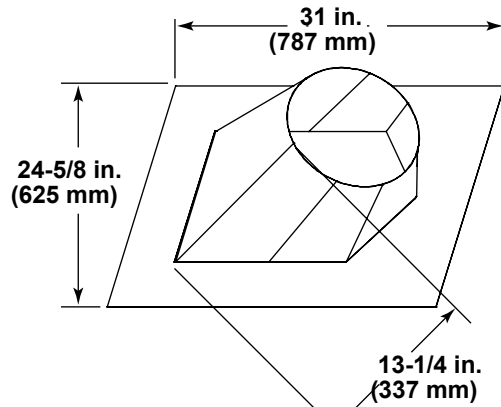

RF12
Roof Flashing

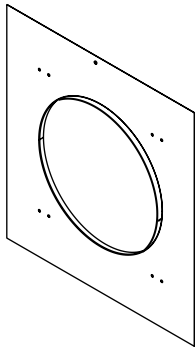

DVP-TRAPFL
Flashing

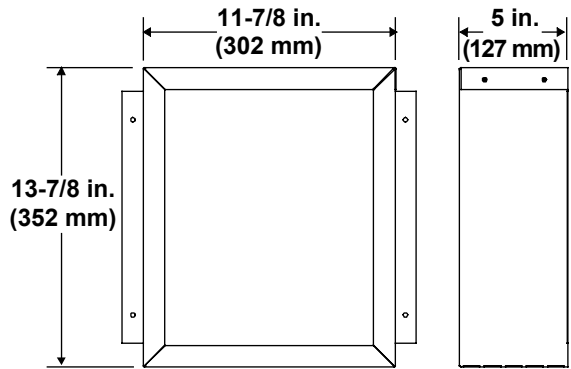

DVP-BEK2
DVP-HPC Cap Brick Extension

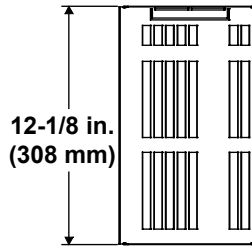
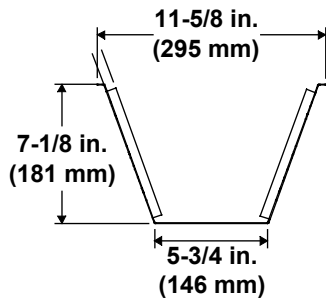

COOL-ADDM
Cap Shield

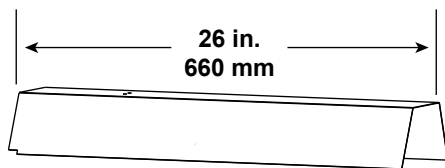
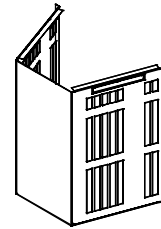

DVP-HSM-B
Extended Heat Shield

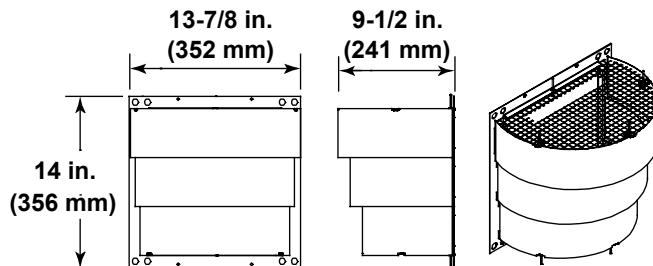

DRC-RADIUS
Cap Shield

Figure 12.3 DVP Vent Components

A. Vent Components Diagrams (continued)

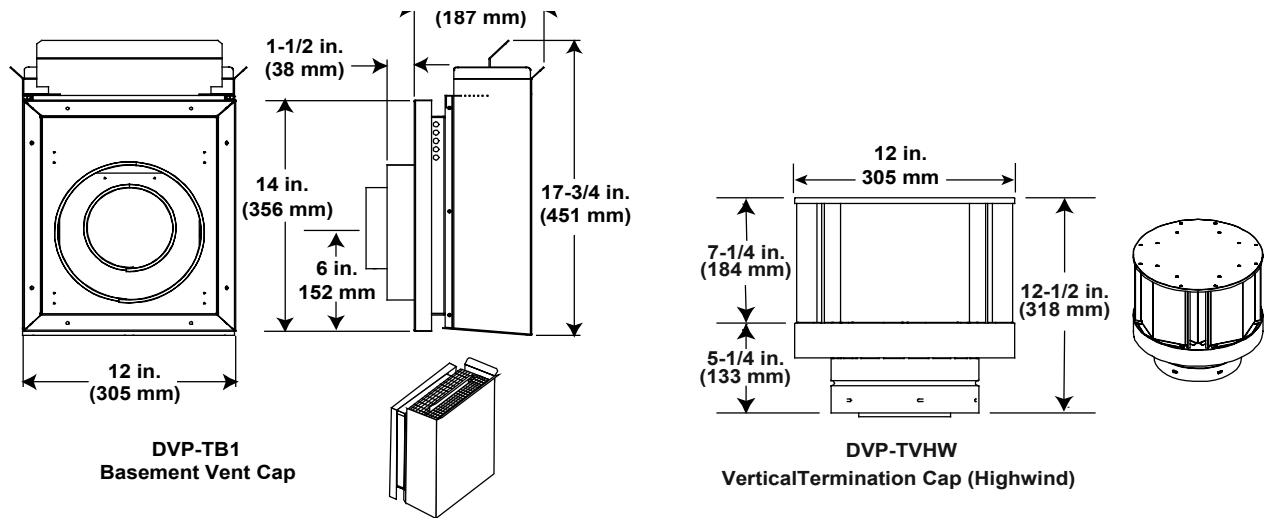

Figure 12.4 Vent Components

DECORATIVE TERMINATIONS/SHROUDS

Only use listed decorative termination caps/shrouds with Hearth & Home Technologies approved venting systems.

This applies to both DVP and SLP venting systems.

Decorative Terminations Caps/Shrouds

DTO134
DTO146
DTS134
DTS146
LDS33
LDS46
LDS-BV

A. Vent Components Diagrams (continued)

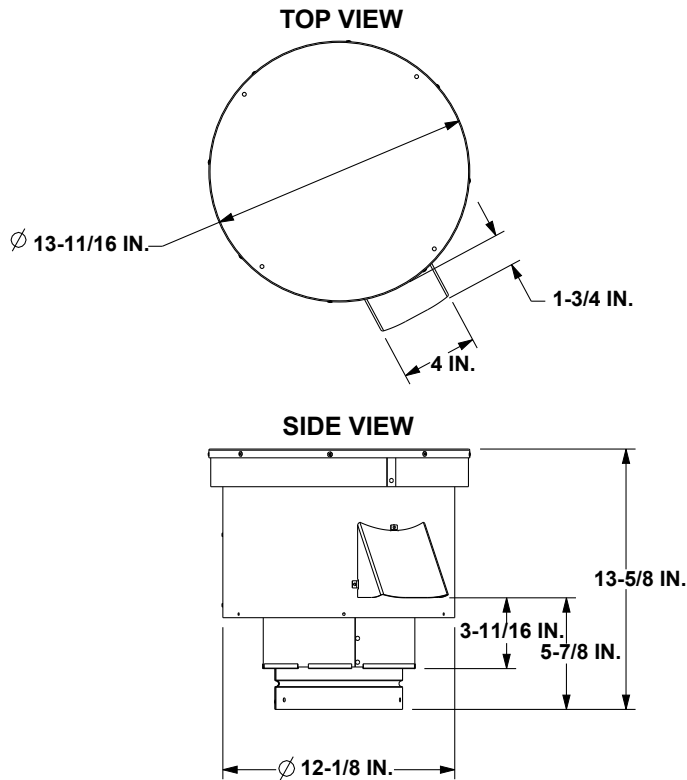

PVV-SLP
Vertical Power Vent

Required Wire Harness and PVV-SLEEVE	
Lengths Available	Part Number
10 ft. PV Wire Harness	PVI-WH10
20 ft. PV Wire Harness	PVI-WH20
40 ft. PV Wire Harness	PVI-WH40
60 ft. PV Wire Harness	PVI-WH60
80 ft. PV Wire Harness	PVI-WH80
100 ft. PV Wire Harness	PVI-WH100
Description	Part Number
12 in. Wire Harness Sleeve	PVV-SLEEVE-12
48 in. Wire Harness Sleeve	PVV-SLEEVE-48

Note: A wire harness is required to power the PVV-SLP and connect it to the appliance. It is ordered separately from the PVV-SLP. Contact your dealer to order.

Note: The PVV-SLEEVE-12 and/or PVV-SLEEVE-48 is required to be installed with the PVV-SLP. It is ordered separately from the PVV-SLP. Contact your dealer to order.

Figure 12.5 PVV-SLP Vent Components

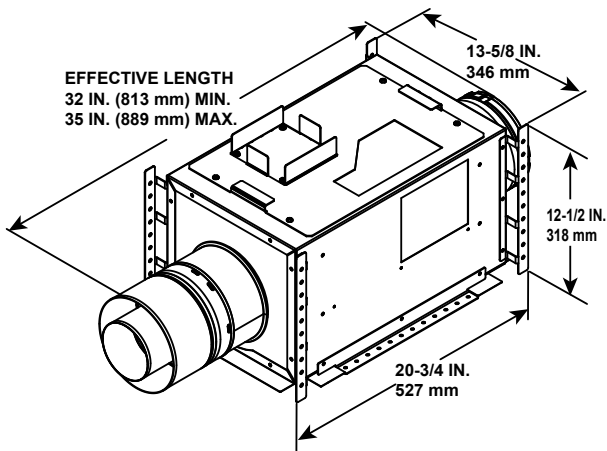

**PVI-SLP-B
Power Vent Inline**

Optional Wire Harness	
DESCRIPTION	PART NUMBER
10 FT PV Wire Harness	PVI-WH10
20 FT PV Wire Harness	PVI-WH20
40 FT PV Wire Harness	PVI-WH40
60 FT PV Wire Harness	PVI-WH60
80 FT PV Wire Harness	PVI-WH80
100 FT PV Wire Harness	PVI-WH100

Note: Wire harnesses required to power the PVI-SLP-B connect to the appliance and are ordered separately from PVI-SLP-B. Contact your dealer to order.

Note: The PVI-SLP-B requires one of the following options to be installed on this appliance.

Option A: IFT-RC400 **OR**

Option B: IFT-RC150, IFT-ACM

These accessories are purchased separately from the PVI-SLP-B. Contact your dealer to order.

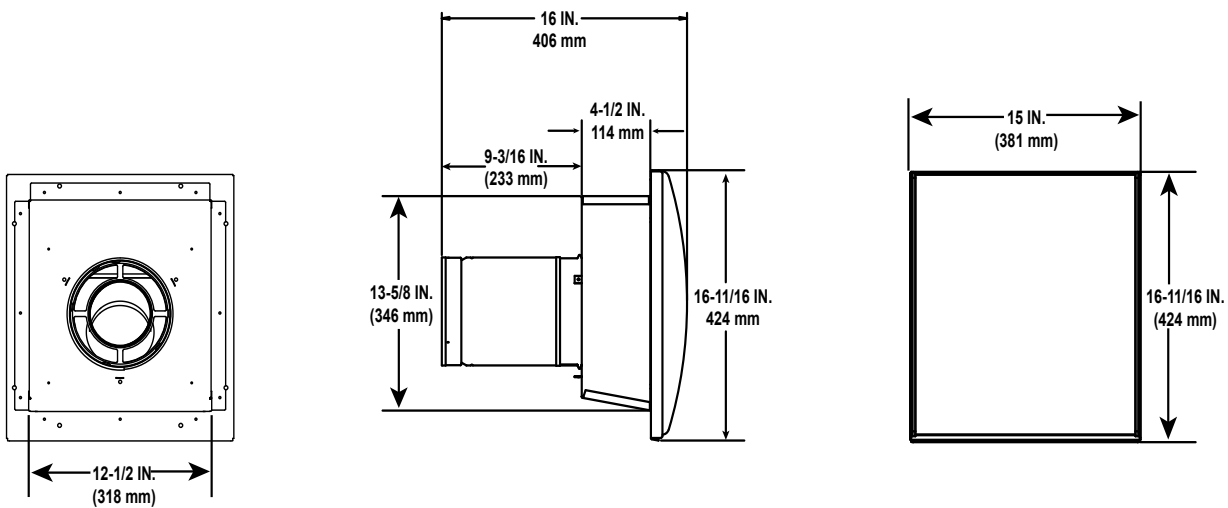

**SLP-LPC
SLP Low Profile Cap
(Approved for use with PVI-SLP-B only)**

Figure 12.6 PVI-SLP-B Vent Components

A. Vent Components Diagrams (continued)

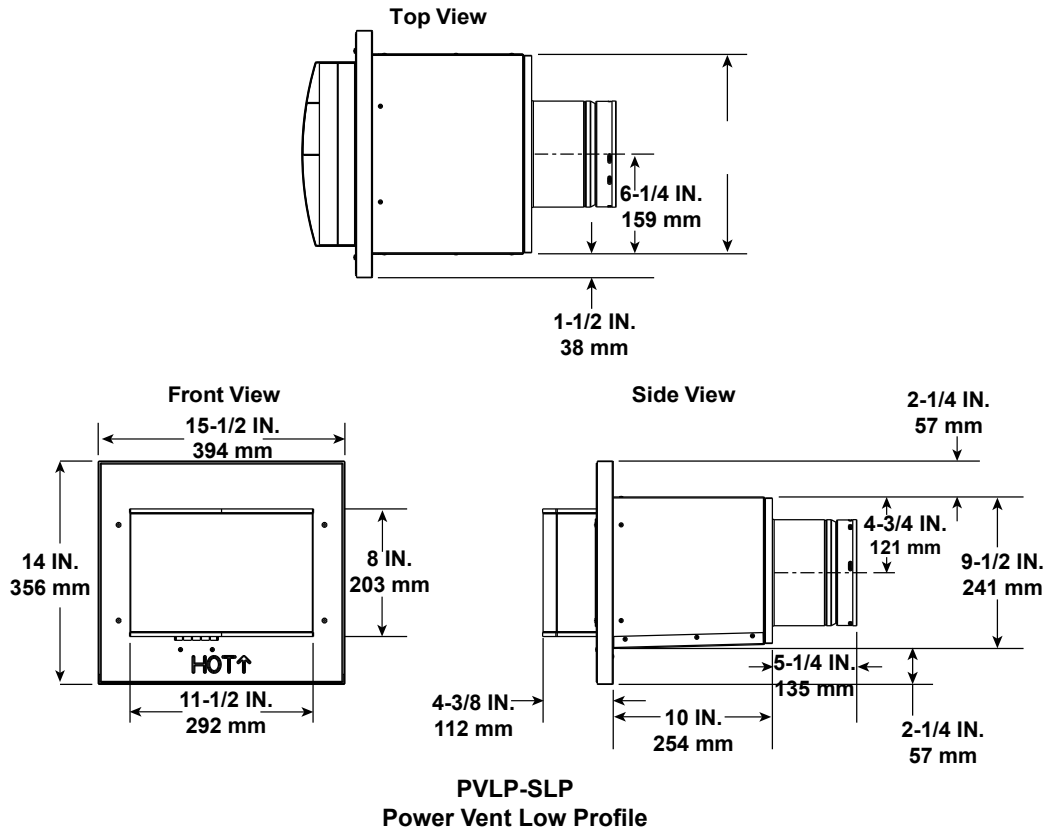

Note: Wire harnesses required to power the PVLP-SLP connect to the appliance and are ordered separately from PVLP-SLP. Contact your dealer to order.

Note: A PVLP-HS heat shield is available and sold separately. Use if the PVLP-SLP is installed in a high traffic area.

Note: The PVLP-SLP requires one of the following options to be installed on this appliance.

Option A: IFT-RC400 or Option B: IFT-RC150, IFT-ACM.

These accessories are purchased separately from the PVLP-SLP. Contact your dealer to order.

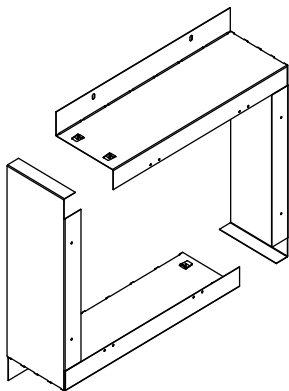

**PVLP-BEK
Brick Kit**

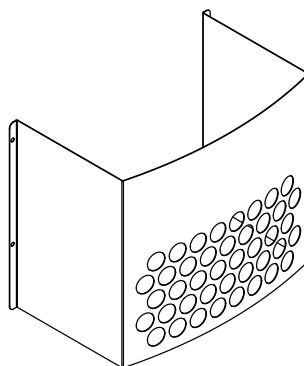

**PVLP-HS
Heat Shield**

Required Wire Harness	
DESCRIPTION	PART NUMBER
10 FT PV Wire Harness	PVI-WH10
20 FT PV Wire Harness	PVI-WH20
40 FT PV Wire Harness	PVI-WH40
60 FT PV Wire Harness	PVI-WH60
80 FT PV Wire Harness	PVI-WH80
100 FT PV Wire Harness	PVI-WH100

Figure 12.7 PVLP-SLP Vent Components

B. Accessories

Remote Controls, Wall Controls and Wall

Switches

Follow the instructions supplied with the control installed to operate your fireplace:

For safety:

- Install a switch lock or a wall/remote control with child protection lockout feature.
- Keep remote controls out of reach of children.

See your dealer if you have questions.

Optional Heat-Zone® Gas Kit

An optional Heat-Zone® Kit is available for your appliance. It must be installed by a qualified service technician during the appliance installation process. Follow the instruction supplied with the kit for operation.

Heat & Glo, a brand of Hearth & Home Technologies
7571 215th Street West, Lakeville, MN 55044
www.heatnglo.com

Please contact your Heat & Glo dealer with any questions or concerns.
For the location of your nearest Heat & Glo dealer,
please visit www.heatnglo.com.

Printed in U.S.A. - Copyright 2025