



**Tiara**  
YACHTS

2022 OWNERS MANUAL

**39**  
OPEN

## CALIFORNIA PROPOSITION 65 WARNING



### WARNING

**WARNING:** Operating, servicing and maintaining a recreational marine vessel can expose you to chemicals including engine exhaust, carbon monoxide, phthalates, and lead, which are known to the State of California to cause cancer and birth defects or other reproductive harm. To minimize exposure, avoid breathing exhaust, service your vessel in a well-ventilated area and wear gloves or wash your hands frequently when servicing this vessel. For more information go to [www.P65warnings.ca.gov/marine](http://www.P65warnings.ca.gov/marine).

*Per California law, the label below is affixed to your boat's helm console. Should you need a replacement, contact Tiara Yachts customer service and request safety label #5450131.*

### EMISSIONS CONTROL SYSTEM INFORMATION

MEETS 2022 MY CALIFORNIA EVAP EMISSIONS  
REGULATIONS FOR SPARK-IGNITION MARINE WATERCRAFT

MANUFACTURER: **S2 YACHTS, INC.**

CALIFORNIA EVAP FAMILY: **NTRAPVSSL001**

EMISSION CONTROL SYSTEM: **CP**

5450131



Welcome to the family of Tiara Yachts boat owners and congratulations on your purchase of your new Tiara.

We understand there are many choices available to you, and we appreciate the investment that you've made and the subsequent faith and confidence that you've placed into our product. Hopefully, during the selection and buying process, you discovered that each Tiara has been designed, engineered, and built with care and precision.

When our company was started, it was the goal of my father, Leon Slikkers, to provide you with the finest quality boat available. We want to be the best and deliver the best to you. And part of that includes a delightful ownership experience. Everything we have achieved since our humble beginnings has been with this same goal in mind.

The information within this owner's manual was assembled to assist you in understanding how to operate your boat to obtain the maximum enjoyment of your Tiara. So please take time to read the manual completely and please operate your boat safely and courteously.

I would also like to ask you a personal favor. Shortly, you will receive a survey asking for your opinion about the sales process you experienced when you purchased your boat. Approximately nine months later, you'll be sent another survey inquiring about your ownership experience. By taking a few minutes to complete these surveys, you will be providing us with valuable information.

Best wishes for many happy hours aboard your new Tiara Yacht,

A handwritten signature in blue ink, appearing to read "T. Slikkers", with a long horizontal flourish extending to the right.

Thomas B. Slikkers  
CEO/President S2 Yachts

**This page intentionally left blank.**

## LIMITED WARRANTY

### 2022 MODELS S2 YACHTS, INC. LIMITED WARRANTY COVERAGE

S2 Yachts, Inc. (S2) provides limited warranty coverage on Tiara Yachts products sold for use by retail (non-commercial) customers, as described in this Limited Warranty. For customers in the U.S.: this warranty gives you specific legal rights; you also may have other rights, which vary from state to state. For customers in the European Union: the purchaser may have additional legal rights under applicable national legislation governing the sale of consumer goods, and those rights (if applicable) are not affected by this warranty.

This warranty is provided only to the original purchaser of the boat from an authorized S2 Yachts dealer, but can be transferred to subsequent owners. Contact S2's Customer Relations Department if you need information about transferring this warranty. No warranty coverage is provided to subsequent owners unless they follow S2's transfer procedures. This warranty does not extend or apply to anyone else. The terms of this written warranty cannot be changed or modified, except by a written agreement signed by an officer of S2 Yachts, Inc.

#### COVERED PRODUCTS AND LIMITATIONS:

S2's limited warranty coverage applies only to:

1. Defects in materials and workmanship in the boat and all components and accessories (except for the excluded items described below) for a period of two (2) years;
2. Structural defects in materials and workmanship in the hull and deck for a period of five (5) years;
3. Blistering due to defects in material and workmanship in the gelcoat surface of the hull bottom for a period of five (5) years, provided that the gelcoat surface has not been altered in any way such as sanding, sandblasting or application of a coating other than standard antifouling paint, any of which will void this warranty.

Each of the warranty coverage periods runs from the date of purchase of the boat from an authorized S2 Yachts dealer and applies only to warranted defects that first manifest themselves and are reported to S2 within the applicable warranty period. S2 retains the right to determine to its reasonable satisfaction whether any claimed defect is covered by this warranty.

Certain items are excluded from warranty coverage by S2, and this limited warranty coverage does not apply to:

1. Engines, transmissions, generators, air conditioning systems, swim platforms and lifts, seakeeping systems, electronics and batteries. These products may come with separate warranties from their manufacturers; see the Owner Packet for warranty registration requirements and details on these products.
2. Dealer final assembly and pre-delivery commissioning, and dealer installed components.
3. Scratching, chipping, discoloration or flaking of any powder coated or painted surface including engines and hardtop components.
4. Gelcoat stress cracking, chalking, fading or discoloration. This includes bilge gelcoat.
5. Damage caused by accident, wear, storm damage, grounding, towing, commercial use of the boat, or misuse or abuse, or deterioration resulting from normal use (including gaskets, seals, springs, wipers and sealants).
6. Maintenance, adjustments or realignments to any components including latches, hinges, hatches, doors and drive train components.
7. Mold, mildew, upholstery damage or deterioration and cleaning.
8. Damage or deterioration resulting from environmental conditions, including electrolysis, crevice or galvanic corrosion, any deterioration of underwater equipment, or any damage or deterioration resulting from any failure to undertake reasonable, routine maintenance.

9. Any repairs, adjustments, alterations or modifications made by anyone other than an employee of S2 Yachts, or an authorized S2 Yachts dealer with S2's prior, written authorization.
10. Damage which has occurred as a result of the boat being operated as a demonstrator and/or displayed for sale.
11. Damage or deterioration of the hull or deck structure due to the attachment of hardware or other components.
12. Weight, speed, fuel consumption or other performance characteristics.
13. Damage or deterioration resulting from improper trailering, hauling, launching or storage.
14. Boats purchased or used for commercial or governmental purposes or uses.

#### REMEDIES UNDER THIS LIMITED WARRANTY

If a defect covered by this warranty occurs, S2 (or one of its authorized dealers, as determined by S2) will repair and replace the defective component, in its sole discretion. This 'repair or replacement' remedy is the exclusive remedy under this warranty. S2 has no responsibility or liability for any consequential or incidental damages, such as loss of use, storage charges, interest or finance charges, insurance or depreciation, transportation or lodging charges, or charges for towing or hauling out, etc. which are specifically excluded and disclaimed from this warranty. For customers in the U.S.: some states do not allow the exclusion or limitation of incidental or consequential damages, so the above limitation or exclusion may not apply to you. UNDER CERTAIN APPLICABLE LAWS, THERE MAY BE NO IMPLIED WARRANTIES OR GUARANTEES FROM S2 APPLICABLE TO YOUR BOAT, AND ALL IMPLIED OR STATUTORY CONDITIONS AND WARRANTIES (INCLUDING ANY WARRANTY OF MERCHANTABILITY OR FITNESS FOR A PARTICULAR PURPOSE) AND GUARANTIES ARE DISCLAIMED WHERE ALLOWED BY LAW. TO THE FULLEST EXTENT ALLOWED BY LAW, ANY AND ALL APPLICABLE IMPLIED WARRANTIES AND GUARANTIES (IF ANY), INCLUDING ANY IMPLIED WARRANTY OF MERCHANTABILITY OR PARTICULAR PURPOSE, ARE LIMITED IN DURATION TO THE DURATION OF THE APPLICABLE PROVISIONS OF THIS WRITTEN WARRANTY. For customers in the U.S.: some states do not allow limitations on how long an implied warranty lasts, so the above limitation may not apply to you.

#### RESPONSIBILITY OF PURCHASER

1. No warranty coverage is provided by S2 unless the customer and dealer complete and return all Vessel Registration and Customer Acceptance Forms to S2 Yachts, Inc. within thirty (30) days after delivery of the boat to the original purchaser.
2. The original purchaser or approved transferee must notify the S2 Yachts dealer from which the boat was purchased of any claimed defect within fifteen (15) days after first detecting the claimed defect. Warranty work in excess of \$500 requires S2's prior written approval.
3. If the dealer fails to satisfactorily repair the claimed defect within fifteen (15) days, written notice must then be promptly given directly to S2. S2 is not responsible for unreported warranted defects.
4. The boat, including any claimed defective part, must be returned to the S2 Yachts dealer from which the boat was purchased (or to another dealer or facility as directed by S2 Yachts) within the warranty period for inspection and warranty service. The expense of returning and transporting the boat or any part for warranty service, and the expense of returning and transporting it back to the owner after repair or replacement, is the responsibility of the owner, and will not be reimbursed by S2.
5. If the dealer from whom the boat was purchased is no longer an authorized S2 Yachts dealer, contact S2 for instructions on how to obtain warranty service.

S2 reserves the right to improve its products through changes in design or materials without being obligated to the owners of the boats of similar or the same model of prior manufacture. We may be contacted as follows: Tiara Customer Relations Department, 725 East 40th Street, Holland, Michigan 49423 (616/394-7460).



## SUPPLEMENTAL LIMITED WARRANTY INFORMATION ON FINISHED WOOD COMPONENTS

Your Tiara Yachts® Boat may be furnished with certain finished wood panels and components that require periodic maintenance and refinishing to maintain their appearance and finish. S2 Yachts, Inc.'s Limited Warranty coverage does not include the matching of wood grains, or the condition or durability of any finishes for such panels and components. This statement supplements S2 Yachts, Inc.'s Limited Warranty with respect to these wood panels and components. All other terms of S2 Yachts, Inc.'s Limited Warranty remain in effect, and you should refer to the Limited Warranty for other terms, conditions and requirements

---

## CALIFORNIA EVAPORATIVE EMISSIONS CONTROL SYSTEM WARRANTY STATEMENT: YOUR WARRANTY RIGHTS AND OBLIGATIONS

The California Air Resources Board and S2 Yachts, Inc. is pleased to explain the evaporative emission control system's warranty on your 2022 model year spark-ignition marine watercraft. In California, new spark-ignition marine watercraft (SIMW) must be designed, built, and equipped to meet the State's stringent anti-smog standards. S2 Yachts, Inc. must warrant the evaporative emission control system on your spark-ignition marine watercraft for the period listed below provided there has been no abuse, neglect, or improper maintenance of your SIMW.

Your evaporative emissions control system may include parts such as: canisters, carburetors, clamps, connectors, filters, fuel caps, fuel lines, fuel tanks, valves, vapor hoses, and other associated evaporative emissions control system components.

### MANUFACTURER'S WARRANTY COVERAGE:

This evaporative emission control system is warranted for two years. If any evaporative emission-related part on your SIMW is defective, the part will be repaired or replaced by S2 Yachts, Inc.

### OWNER'S WARRANTY RESPONSIBILITIES:

- As the spark-ignition marine watercraft owner, you are responsible for performance of the required maintenance listed in your owner's manual. S2 Yachts, Inc. recommends that you retain all receipts covering maintenance on your spark-ignition marine watercraft, but S2 Yachts, Inc. cannot deny warranty solely for the lack of receipts.
- As the spark-ignition marine watercraft owner, you should however be aware that S2 Yachts, Inc. may deny you warranty coverage if your spark-ignition marine watercraft or a part has failed due to abuse, neglect, or improper maintenance or unapproved modifications.
- You are responsible for presenting your spark-ignition marine watercraft to a S2 Yachts, Inc. dealer or authorized service center as soon as the problem exists. The warranty repairs should be completed in a reasonable amount of time, not to exceed 30 days. If you have a question regarding your warranty coverage, you should contact S2 Yachts, Inc. at 1-616-392-7163.

The California evaporative emissions control system warranty covers the following list of components:

- |                                     |  |
|-------------------------------------|--|
| (1) Canister Mounting Brackets      | (12) Fuel Line Fittings  |
| (2) Carbon Canister                 | (13) Fuel Tank   |
| (3) Carburetor Purge Port Connector | (14) Liquid/Vapor Separator  |
| (4) Clamps*                         | (15) Pressure Relief Valves*   |
| (5) Control Cables*                 | (16) Purge Valves  |
| (6) Control Linkages*               | (17) Vacuum Control Diaphragms*  |
| (7) Control Solenoids*              | (18) Vapor Hoses   |
| (8) Control Valves*                 | (19) All other parts not listed that may affect the evaporative emissions control system |
| (9) Electronic Controls*            |  |
| (10) Fuel Cap                       |  |
| (11) Fuel Line                      |  |

\*Note: As they relate to the evaporative emissions control system.

# IMPORTANT INFORMATION

---

Your Tiara Owner's Manual has been written to include a number of safety instructions to assure the safe operation and maintenance of your boat. These instructions are in the form of **WARNING** and **CAUTION** statements. The following definitions apply:

All instructions given in this book are as seen from the stern looking toward the bow, with starboard being to your right, and port to your left. A glossary of boating terms is included in the Appendix.



## DANGER

DANGER INDICATES A HAZARDOUS SITUATION WHICH, IF NOT AVOIDED, WILL RESULT IN DEATH OR SERIOUS INJURY.



## WARNING

WARNING INDICATES HAZARDS OR UNSAFE PRACTICES WHICH COULD RESULT IN SEVERE PERSONAL INJURY OR DEATH.



## CAUTION

CAUTION indicates hazards or unsafe practices which could result in minor personal injury, or product and property damage.

## NOTICE

NOTICE is used to address best practices not related to physical injury.

**IMPORTANT NOTE:** Your boat uses internal combustion engines and flammable fuel. Every precaution has been taken by Tiara Yachts to reduce the risks as-

## IMPORTANT INFORMATION

sociated with possible injury and damage from fire or explosion, but your own precaution and good maintenance procedures are necessary in order to enjoy safe operation of your boat.

If for any reason you have trouble with your Tiara Owner's Manual, or require replacement pages, please contact our Customer Service department at the address on the cover page. We will be happy to supply replacement pages at no charge.

This manual has been compiled to help you to operate your craft with safety and pleasure. It contains details of the craft, the equipment supplied or fitted, its systems, and information on its operation and maintenance. Please read it carefully, and familiarize yourself with the craft before using it.

If this is your first craft, or you are changing to a type of craft you are not familiar with, for your own comfort and safety, please ensure that you obtain handling and operating experience before assuming command of the craft. Your dealer or national sailing federation or yacht club will be pleased to advise you of local sea schools, competent instructors, and reference material.

**PLEASE KEEP THIS MANUAL IN A SECURE PLACE, AND PRESENT IT TO THE NEW OWNER WHEN YOU SELL THE CRAFT.**

Owner's manuals for the installed equipment on your boat have also been provided for your reference. They have been stored in a valise that is included in your new boat. Please read this information, and also hand them over to the new owner when you sell the boat.



# TABLE OF CONTENTS

---

## Chapter 1: EXTERIOR EQUIPMENT AND FEATURES

1.1 UPPER COCKPIT .....	1-1
1.1.1 Steering.....	1-1
1.1.2 Engine Controls .....	1-1
1.1.3 Engine Monitoring.....	1-3
1.1.4 Switch and Breaker Panels.....	1-4
1.1.5 Trim Tabs .....	1-7
1.1.6 Equipment Controls .....	1-7
1.1.7 Stereo .....	1-9
1.1.8 Courtesy Lights .....	1-9
1.1.9 Seating, Storage and Access.....	1-9
1.2 LOWER COCKPIT.....	1-10
1.2.1 Dockside Water.....	1-13
1.2.2 Aft Cockpit Floor.....	1-13
1.2.3 Optional Tiara Tournament Series Equipment .....	1-13
1.2.4 Optional Aft Cockpit Sunshade .....	1-14
1.3 SIDE DECKS.....	1-15
1.3.1 Handrails.....	1-15
1.3.2 Fill and Pump-Out Ports.....	1-15
1.4 FOREDECK.....	1-15
1.5 HULL SIDES AND TRANSOM .....	1-16
1.5.1 Transom Door and Gate .....	1-17
1.6 HARDTOP .....	1-17

## Chapter 2: INTERIOR EQUIPMENT AND FEATURES

2.1 MASTER STATEROOM .....	2-1
2.1.1 Berth .....	2-2
2.1.2 Hanging Locker.....	2-3
2.1.3 Outlets, Safety .....	2-3

2.2 CONVERTIBLE DINETTE .....	2-4
2.2.1 A.C. & D.C. System Panels.....	2-5
2.2.2 Waste and Water System Monitor, Bilge Alert .....	2-5
2.3 HEAD.....	2-6
2.3.1 Shower, Vanity, and Vacuflush® Toilet.....	2-6
2.4 GALLEY.....	2-8
2.4.1 Storage .....	2-8
2.4.2 Appliances.....	2-8
2.5 COMPANIONWAY .....	2-9
2.5.1 Remote Control Lighting System .....	2-10
2.6 CARBON MONOXIDE MONITORING .....	2-11

### **Chapter 3:ENGINE ROOM**

3.1 GENERAL ARRANGEMENT .....	3-1
3.1.1 Centerline.....	3-2
3.1.2 Starboard .....	3-3
3.1.3 Port .....	3-3

### **Chapter 4:ELECTRICAL SYSTEMS**

4.1 GENERAL.....	4-1
4.2 12V D.C. SYSTEM .....	4-1
4.2.1 Power supply .....	4-1
4.2.2 Wet Flooded Cell Batteries .....	4-3
4.2.3 Distribution .....	4-3
4.2.4 Operating Notes.....	4-5
4.2.5 12V D.C. Power .....	4-6
4.3 120 / 240V A.C. SYSTEM.....	4-6
4.3.1 Power Supplies .....	4-6
4.3.2 Distribution .....	4-7
4.3.3 Operating Notes.....	4-7

4.4 BONDING SYSTEM .....	4-9
--------------------------	-----

## **Chapter 5: OPERATING YOUR BOAT**

5.1 WHEN ARRIVING AT YOUR BOAT.....	5-1
5.1.1 Connecting to Shore Power .....	5-1
5.1.2 Fueling Your Boat.....	5-2
5.1.3 Fuel System .....	5-4
5.1.4 Filling Your Water Tank .....	5-5
5.1.5 Starting Your Engines .....	5-6
5.1.6 Throttle Operations .....	5-8
5.1.7 Starting the Generator .....	5-8
5.2 LEAVING AND RETURNING TO THE DOCK .....	5-9
5.3 WHILE UNDERWAY .....	5-10
5.3.1 Waste Disposal .....	5-11
5.3.2 Anchoring .....	5-12
5.4 AFTER RETURNING TO THE DOCK .....	5-13

## **Chapter 6: COMMISSIONING YOUR BOAT**

6.1 BEFORE LAUNCHING YOUR BOAT .....	6-1
6.1.1 Bottom Paint .....	6-1
6.1.2 Bilge Areas .....	6-2
6.1.3 Electrical Systems.....	6-2
6.1.4 Installing the Propellers.....	6-3
6.2 LIFTING YOUR BOAT .....	6-5
6.3 AFTER LAUNCHING YOUR BOAT .....	6-6
6.3.1 Fresh Water System .....	6-6
6.3.2 Electrical Systems.....	6-8
6.3.3 Engines and Transmissions .....	6-8
6.3.4 Interior Equipment.....	6-9
6.3.5 Exterior Equipment .....	6-10

## **Chapter 7: ROUTINE MAINTENANCE**

7.1 FUEL SYSTEM.....	7-1
7.2 FRESH WATER SYSTEM .....	7-5
7.3 ELECTRICAL SYSTEM.....	7-6
7.3.1 The 12V D.C. System .....	7-6
7.3.2 The 120V/240V A.C. System .....	7-8
7.4 EXTERIOR EQUIPMENT AND FIBERGLASS .....	7-9
7.4.1 Plexiglass.....	7-10
7.4.2 Hardware .....	7-10
7.4.3 Canvas and Upholstery.....	7-11
7.4.4 Hull Bottom .....	7-11
7.4.5 Underwater Gear .....	7-12
7.4.6 Optional Washdowns .....	7-12
7.5 INTERIOR EQUIPMENT AND DECOR.....	7-12
7.6 ENGINE ROOM.....	7-14
7.6.1 Engines, Transmissions and Generator.....	7-14
7.6.2 Oil Change System .....	7-14
7.6.3 Stuffing Boxes.....	7-14
7.6.4 Ventilation System .....	7-16
7.6.5 Raw Water Intake Strainers .....	7-16
7.7 RAW WATER SEACOCKS.....	7-17
7.8 HEAD SYSTEM.....	7-17
7.9 DRAINAGE SYSTEM .....	7-19
7.10 AIR CONDITIONER FILTERS .....	7-19

## **Chapter 8: STORING AND WINTERIZING YOUR BOAT**

8.0.1 Supporting the Boat During Storage.....	8-1
8.0.2 Storage .....	8-1
8.1 FUEL SYSTEM.....	8-1

8.2 FRESH WATER SYSTEM .....	8-2
8.3 ELECTRICAL SYSTEM.....	8-3
8.3.1 12V D.C. System .....	8-3
8.3.2 120V A.C. System.....	8-4
8.4 EXTERIOR EQUIPMENT AND FIBERGLASS .....	8-4
8.5 INTERIOR EQUIPMENT .....	8-5
8.5.1 Air Conditioning.....	8-5
8.5.2 Head System .....	8-6
8.6 ENGINE ROOM AND BILGE AREAS.....	8-6
8.6.1 Engines, Transmissions and Generator.....	8-6
8.6.2 Exhaust Systems .....	8-7
8.6.3 Raw Water Systems.....	8-8
8.6.4 Steering System.....	8-10

**Appendix A: SPECIFICATIONS**

**Appendix B: GLOSSARY**

**Appendix C: MAINTENANCE GUIDES**

**Appendix D: MAINTENANCE SCHEDULES**

**Appendix E: ACCIDENT REPORTS**

**Appendix F: FLOAT PLAN**

**Appendix G: TROUBLESHOOTING**

**Addendum: FRESH WATER SYSTEM**

This page intentionally left blank.

## Addendum

# FRESH WATER SYSTEM

---

Reference the addendum at the end of this manual for additional fresh water system information.

The fresh water system must be disinfected before first use and yearly at the beginning of each season. A clean sanitized fresh water system will greatly reduce the risk of developing coliform bacteria or other disease-causing organisms (pathogens) and will help protect the health of everyone onboard.



## **WARNING**

**DISINFECT THE ENTIRE FRESH (POTABLE) WATER SYSTEM PRIOR TO USE AND YEARLY AT THE BEGINNING OF EACH SEASON. FAILURE TO DO SO CAN RESULT IN DEVELOPING COLIFORM BACTERIA OR OTHER DISEASE-CAUSING ORGANISMS (PATHOGENS) IN THE WATER SYSTEM. CONSUMPTION OF CONTAMINATED WATER COULD RESULT IN SEVERE PERSONAL INJURY OR DEATH.**

**This page intentionally left blank.**



## Chapter 1

# EXTERIOR EQUIPMENT AND FEATURES

---

## 1.1 UPPER COCKPIT

### 1.1.1 Steering

To starboard of the companionway door is the console of your Tiara 39 (see **Figure 1-1**). In the center, on the vertical face, is the steering wheel which is connected to a hydraulic pump behind the console. This hydraulic pump operates a hydraulic cylinder at the stern of your boat and controls rudders on the port and starboard sides.

### 1.1.2 Engine Controls

**Please see Section 5.1.5 for engine cranking procedures.** The single lever electronic engine controls are on the starboard side of the helm. The throttle handles (port handle for port engine, starboard handle for starboard engine) are vertical when the engine transmissions are in neutral. The engines are shifted into forward by pushing the handles forward from vertical and are shifted into reverse by pulling the handles aft from vertical. When shifting from forward to reverse, or vice versa, you should pause momentarily at neutral.



*Figure 1-1: Helm Console*

**Ignition panel** (see **Figure 1-2**): The port key starts the port engine, and the starboard key starts the starboard engine. Turning an ignition key clockwise, the first position is ON - which turns on power to the engines ignition system, gauges, alarms, and Cummins® displays. The second position is start. This is a momentary position so when you release the key, it springs back to ignition ON. Turning an ignition key counter clockwise turns the engine OFF, shutting down power to the engines ignition systems, gauges, alarms, and the Cummins® displays.

 **CAUTION**

**Only shift from forward to neutral to reverse with the engines at idle speed. Failure to do so could result in severe transmission damage.**

Below the two ignition keys is the **battery parallel switch**. This switch would be activated, if needed, to use both engine and house battery banks to crank the engine. The switch must be activated continuously while cranking and will return to nonparallel mode when released. Please see Section 5.1.5 for engine cranking procedures.

Optionally a bow thruster is available. The optional bow thruster controls are on the helm. Please see the literature provided by the manufacturer for operation guidelines.



*Figure 1-2: Ignition Panel*

**The helm console** is held closed at its forward edge by a screw in knob. To access the back side of all console electrical equipment, electronics, engine controls, steering system pump, and engine instrumentation, unscrew the knob and pull the helm console aft.

 **WARNING**

**DO NOT OPERATE THE VESSEL UNDER POWER WITH THE TRANSOM DOOR OR GATE OPEN. OPERATION OF BOAT WITH TRANSOM DOOR AND GATE OPEN MAY ALLOW PERSONS TO FALL OVERBOARD AND INTO BOAT PROPELLERS OR TO BE LOST IN OPEN WATER.**



## CAUTION

The console must be securely fastened in the forward position while operating the boat. Failure to do so may result in unexpected movement of the helm console.



## CAUTION

All repairs to items in your Tiara 39 console should be serviced by a marine electrician or mechanic. Failure to do so could result in damage to equipment or difficulty in safely operating the boat.

### 1.1.3 Engine Monitoring

The Cummins® engine data display consists of one display unit per engine. Please consult the Cummins Marine® *Engine Data Display User's Guide*, supplied in the boat ship kit, for specific operation.

There are analog fuel gauges installed on the console:

- **Fuel Gauges** - Indicates level of fuel in the fuel tank, in fractions of a full tank. The port side gauge shows the level in the aft tank and the starboard gauge shows the level in the forward tank.

Located on the left of the switch panel are **indicator lights** to indicate when any of the bilge pumps are running, and when the generator is running.

**Alarm horns** are located behind the console. Alarms are triggered by an output from the engines. If any of the engine parameters (oil PSI, transmission temp, etc.) goes out of range, the output will turn on an alarm. The electronic engine display will display the fault/warning. See engine manual for additional information on engine alarms.

### 1.1.4 Switch and Breaker Panels

Forward of the wheel are two Helm Switch Panels (see **Figure 1-3**). The panel on the port side contains these switches:

## EXTERIOR

### Helm Switch Panel

- **Port side switches:**
- **ACC** - Open slot for owner installed components.
- **Panel Lights**- An ON-OFF switch that, when switched ON, activates lights in the helm gauge panel and switch panel for use at night.
- **Courtesy Lights** - An OFF-ON switch that, when switched ON, activates the courtesy lights in the lower cockpit.
- **Spreader Lights** - (Optional) An OFF-ON switch that, when switched ON, activates the spreader lights, which illuminate the aft cockpit transom area from below the arch.
- **Underwater Lights** - (Optional) OFF-ON switch that, when switched ON, activates the underwater lights on the transom.
- **Hardtop Lights** - (Optional) An OFF-ON switch that, when switched ON, activates the lights under the hardtop.

*Figure 1-3: Helm Switches and Gauges.*

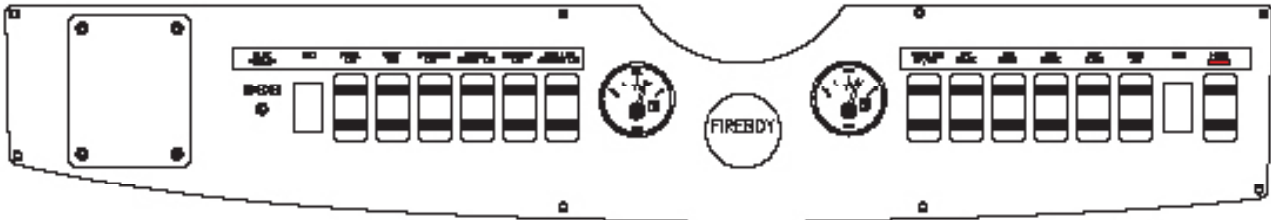

- **NAV/ANC Lights** - An ON-OFF-ON switch that when switched to the upper ON position illuminates the red and green running lights (located on each side of the cabin), the forward white light in the top of the windshield on centerline, and the white stern light on the back of the forward facing cockpit seat. This position is used when operating your boat at night or when visibility is reduced due to weather. The lower ON position lights only the forward and aft white lights in the top of the windshield on centerline. This position is to be used when your boat is anchored at night. Please read and follow the U.S. Coast Guard Navigation Rules for proper nav light usage.

- **Starboard side switches:**

- **Windlass** - (Optional) An UP-OFF-DOWN switch that activates the foredeck anchor windlass to either raise or lower the anchor. This switch is only operable with the optional windlass installation. For this switch to operate the Windlass breaker on the D.C. Distribution panel must be ON.
- **Aft Bilge Pump** - Same as forward bilge pump only for the aft bilge pump, located under the aft cockpit large floor hatch.
- **Mid Bilge Pump** - Same as forward bilge pump only for the mid bilge pump, located in the engine room.
- **Forward Bilge Pump** - An OFF-ON switch that, when switched on, activates the forward bilge pump located under the forward cabin sole.
- **Nav Elect** - An OFF-ON (Optional) switch that is an emergency shut off for the auto pilot.
- **Helm Air** - Open for owner installed components.
- **ACC** - Open for owner installed components.
- **Horn** - A momentary switch which, when pressed, blows the boat's horn.

To starboard, forward of the throttles is the Primary Function Switch Panel that contains the following switches, see **Figure 1-1**.

- **Port and Starboard Wiper Switch Function:**

Please see the manufacturer's manual for complete operating instructions.

The numbers on the following list correspond to the numbers on **Figure 1-4**.

- 1. Main ON/OFF switch. Turns main power to the system ON and OFF. Press and hold for the washer to spray fresh water on the windshield. The fresh water pump and the wipers must be ON for the washer to work.
- 2. Increase speed. Faster stroke time. In intermittent mode the frequency of wiping is decreased.
- 3. Decrease speed. Slow stroke time. In intermittent mode the frequency of wiping is increased.

## EXTERIOR



*Figure 1-4:  
The windshield  
wiper switch  
(one for port  
and one for  
starboard).*

By pressing button 1 or 2, the wiper can be switched ON. By pressing button 1, the wiper will stop; in the park position.

The three LED's shows the controller operation setting. By pressing any button the mode will change and the LED's will flash as many times as the delay times (in seconds) between the wiper strokes. If 4 seconds is the delay times between the wiper strokes, the LED will flash 4 times. A light will flash – slowly if a SLOW speed is selected and quickly when a FAST speed is selected.

- **Trim Tabs** - Reference Section 1.1.5 for operation of the Trim Tab Control Switches.

On the backside of the helm console is the helm breaker panel (see **Figure 1-5**). This panel contains the circuit breakers for all circuits not protected by the cabin D.C. Distribution Panel.

All breakers are covered with a waterproof boot for their protection. In the event a breaker is tripped, investigate possible causes for circuit overload and then reset by pressing in on the center of breaker.

### 1.1.5 Trim Tabs

Located on the helm Switch Panel, forward of the throttle controls, at the lower right corner, are the trim tab rocker switches. These switches control the operation of the port and starboard trim tabs located in the transom, at the boat bottom. The trim tabs can control the fore and aft “trim” and port and starboard “heel” of your boat while it is on plane.

To lower the starboard bow, press the starboard switch at the top. To raise the starboard bow, press the starboard switch at the bottom. The same works for the port bow up and down.

**Note:** Pressing the starboard switch at the top to lower the starboard bow will actually activate the port trim tab to go down. The same works for the port tab.

### 1.1.6 Equipment Controls

At the top of the console is the **compass**. A compass indicates the



*Figure 1-5: The helm breaker panel  
behind the console.*

direction the bow of your boat is headed. The compass in your Tiara 39 should be maintained and compensated by a Tiara dealer, or other qualified marine service facility, for magnetic variance associated with operating your boat in your particular location.

Below the steering wheel, in the vertical face of the console, is the fire system indicator. The fire extinguishing bottle for the system is located in the engine room, on the forward bulkhead. For specific information on how the fire system works, refer to the owner's manual provided by the fire system manufacturer.

The optional ACR® RCL100 **Remote Spotlight** control is located to inboard of the steering wheel. For specific operating instructions, refer to the information provided by the equipment manufacturer.

Fire on a boat is a very serious matter. Become familiar with fire prevention and related maintenance procedures, and make them a part of your regular procedures. Make sure all emergency gear is in good condition, and ready for use if needed. Make sure you and your crew are familiar with emergency procedures and the location of all emergency equipment, and that everyone is prepared to respond in the event of an emergency.



## CAUTION

**When backing your boat at more than idle speed depress both trim switches at the bottom to fully retract tabs. Failure to do so could result in damage to trim tab hydraulic cylinders.**

### 1.1.7 Stereo

The cockpit **stereo controls** are located on the console. Please refer to the stereo manufacturer's literature for operation guidelines. The cockpit **stereo speakers** are provided throughout the cockpit. The subwoofer is under the port lounge.

### 1.1.8 Courtesy Lights

**Courtesy lights** are located throughout the cockpit. The courtesy lights are operated from the helm switch panel or the courtesy light remote control.

## EXTERIOR

### 1.1.9 Seating, Storage, Conveniences

Standard **helm seating** in your Tiara 39 includes an oversized starboard helm seat and a large port L-lounge. Optionally a refrigerator can be installed in the helm seat storage area.

Aft of the helm seat is a **wet bar** with a faucet, cutting board and three drink holders. The wet bar's lid is held in the open position by a gas shock. Below the wet bar is a storage drawer or optionally a **drawer style refrigerator**. The optional refrigerator has a latch to secure it in place while underway. Please read the



#### **WARNING**

**IF A FIRE OCCURS, TURN OFF ALL MAIN ELECTRICAL SWITCHES, ALL ENGINES, ALL POWERED VENTILATION, AND SHUT DOWN THE GENERATOR. EXTINGUISH ALL SMOKING MATERIALS. DO NOT OPEN THE ENGINE ACCESS HATCH OR LARGE ENGINE HATCH. CALL FOR HELP IMMEDIATELY.**



#### **WARNING**

**BEFORE INSPECTING FOR DAMAGE, ALLOW THE EXTINGUISHER AGENT TO "SOAK" THE COMPARTMENT FOR AT LEAST 15 MINUTES AND WAIT FOR HOT METALS OR FUELS TO COOL. HAVE APPROVED PORTABLE EXTINGUISHERS IN HAND AND READY FOR USE. FIRE FIGHTING CHEMICALS, SMOKE FROM A FIRE, AND ENGINE EXHAUST DURING A FIRE GIVE OFF HAZARDOUS AND TOXIC GASES, WHICH CAN CAUSE ASPHYXIATION OR OTHER SERIOUS HEALTH PROBLEMS. IF A FIRE OCCURS, OR THE SYSTEM ACCIDENTALLY DISCHARGES, GET OUT INTO FRESH AIR. DO NOT BREATHE THE FUMES.**



manufacturer's literature for specific operating information. On the forward face of the wet bar, behind a weatherproof cover, is a 120V outlet.

**A tackle storage and bait prep unit** is aft of the wet bar. The aft door has access to tackle drawers or optionally an ice maker with drawer. Open the upper lid to open the aft door. Beneath the upper lid there is a removable cutting board.

Port side seating features a curved companion seat with forward facing jump seat and storage below. See **Figure 1-6** for proper use of the jump seat.

Forward of the port seat is a storage box on the horizontal shroud. The acrylic sliding companionway door with lock, built-in screen, and privacy cover is on centerline.

Between the port and starboard seats is an **engine room access hatch**. This hatch may be opened by using the T-handle latch and is held in the open position by a gas spring.

## 1.2 LOWER COCKPIT

For ease in boarding your Tiara 39 from the dock, and returning to the dock from the cockpit, fixed cockpit steps have been provided port and starboard at the forward end of the aft cockpit. See **Figure 1-7** for an illustration of the cockpit arrangement.

Features of the lower cockpit:

- **Optional Gunnel doors**, port and starboard are magnetically held in place. To open a gunnel door press it in and then pull out. Close and the magnets will hold a door in the closed position.



### CAUTION

**Secure the latch on the optional drawer style refrigerator in the upper cockpit while underway. Failure to secure the refrigerator latch could result in damage to the drawer and or drawer slides.**

## EXTERIOR



*Figure 1-6: To use the jump seat:*

*1. Backrest- align the aft side slide brackets while guiding the forward end between the permanent cushion and outboard cleats.*

*2. Seat- The seat is stowed magnetically. To deploy the seat gently pull the lower edge, with one hand hold the seat and with the other hand guide the support into the aft wedge cleat.*

*Proximity switches are located in the backrest and seat installations. The seat must be stowed and the backrest removed to lift the engine hatch switch, as shown in the upper left photo .*



### **CAUTION**

To lift the engine hatch the jump seat backrest must be removed and the seat bottom stowed.

- The **240V shore power inlet** is behind the starboard gunnel door, see **Figure 1-8**. This power inlet shore power cord has a mechanical recoil feature. Near the fitting is the switch to release the cable, or retrieve it. Place the switch in the middle position when not moving the cable. Please refer to the cable retrieval system manufacturer's owner's manual for more information. Consult Chapter 5, section 5.1.1 "Connecting to Shore Power", for more information.
- **Cockpit shower**, hot and cold water - located in the port entry way of the transom door. See the manufacturer's literature for details.
- **Fresh water washdown** outlet with 25 ft. coiled blue hose. The washdown outlet is located inside the starboard gunnel door, near the shore power inlet. The fresh water pump breaker is on the D.C.



## CAUTION

### After cooking:

- Allow the grill to cool off before closing the lid.
- Clean the grill surface.
- Empty the contents of the drip pan below the grill. Lift the grill grate up and carefully remove the fully cooled drip pan.



**Figure 1-7 Optional Grill Operation**

### *To operate the grill:*

1. Lift the lid. When the lid is closed the forward inboard magnet interacts with a trip breaker that shuts down grill power.
2. See the manufacturer's literature for grill operation.
3. A blind GFI is located in the storage area below the grill. The blind GFI is in the upper left corner of the storage. In the event the grill is not functioning check the GFI.

**NOT FOR USE WHILE UNDERWAY.**

## EXTERIOR

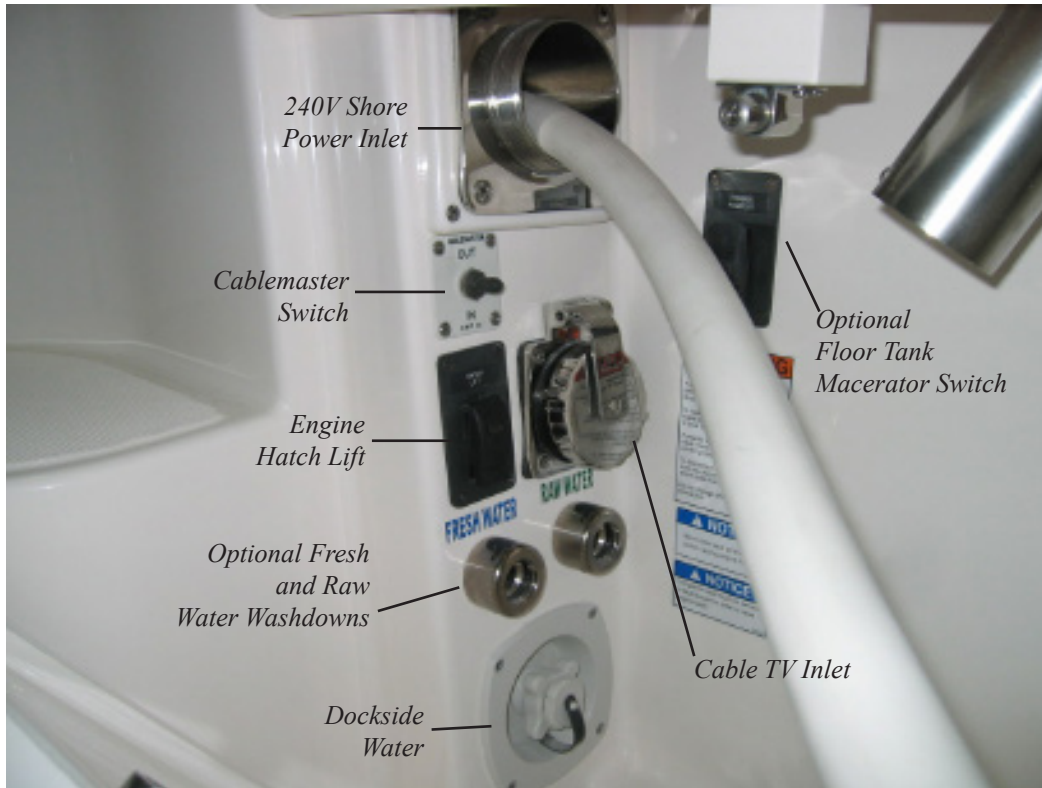

Figure 1-8: Aft of the starboard cockpit step.

Distribution Panel in the cabin. The breaker must be ON for the fresh water pump to supply water to the washdown.

- **Raw water washdown** outlet with 25 ft. coiled yellow hose. The washdown outlet is located inside the starboard gunnel door, near the shore power inlet. The raw water pump breaker is on the D.C. Distribution Panel in the cabin. The breaker must be ON for the raw water pump to supply water to the washdown. A forward raw water washdown is available as an option, the operation is the same as the standard washdown.

### 1.2.1 Dockside Water

The dockside fresh water inlet with regulator is inside of the starboard gunnel door. When a hose from the dock is attached with pressure, your boat's fresh water system is using the dock supplied water, not water from the on board fresh water tank.

**Note:** When using dockside water, the fresh water pump breaker on the D.C. Distribution Panel should be switched OFF.

## 1.2.2 Aft Cockpit Floor

The aft cockpit floor features port and starboard flush floor boxes with split hatches, and a lazarette hatch. Below the aft lazarette hatch there is access to the aft fuel tank hoses, valves and fitting; the trim tab pump; the garboard drain; the steering system, and the optional air conditioning raw water pump, inlet and strainer.

## 1.2.3 Optional Tiara Tournament Series Equipment

- **Tackle drawers** for aft prep center.
- **Macerator** for standard flush floor cockpit storage boxes. With the macerator pump out option the hoses connecting the tanks to the macerator have quick disconnects installed in-line for easy removal. The macerator switch is located inside the starboard gunnel box near the shore power equipment.

### Optional Transom Baitwell:

- Below the aft lazarette hatch, underside of the scupper drain is an orange valve. Adjust the flow rate of raw water to the baitwell tank with the orange valve. The valve can be adjusted for more or less flow depending on conditions or desired turn over rate.
- When using the baitwell for dry storage - shut the valve OFF.
- On the port transom below the covering board is the baitwell switch. This switch turns the raw water pump to the baitwell ON/OFF.
- The baitwell drain is inside the tank. When the lever is DOWN the tank is ready to be filled. When the lever is UP the tank will drain.
- The baitwell lid is removable. Two barrel latches below the lid allow for removal.

## 1.2.4 Optional Aft Cockpit Sunshade

The aft cockpit sunshade system consists of the following equipment:

- Two strut poles stowed in the berth storage.
- A weathermax canopy with grommets and sail track piping.

## EXTERIOR

- Two lines with snap hooks.
- Two aft gunwale mounts.

To deploy the sunshade:

1. Guide the line through the pulley.
2. Set each pole in a gunwale mount. Pull the mount lock forward to firmly seat the pole. Release the lock and test that the pole is firmly locked in place. The pole is correctly mounted when the black line catch is facing forward.
3. Guide the weathermax canopy through the aft sailtrack in the hardtop.
4. Attach the snap hooks to the grommets and pull the line tight to deploy the canopy across the aft cockpit.
5. Guide the line through the black line catch and lock the line into place.

## 1.3 SIDE DECKS

### 1.3.1 Handrails

While moving about the side decks, **handrails** are provided on the aft vertical edge of the radar arch, port and starboard, as well as on the upper edge of the side windshields, port and starboard, for your safety.

### 1.3.2 Fill and Pump-Out Ports

The **aft fuel tank fuel fills** are located port and starboard near the cockpit steps. The **forward fuel tank fuel fills** are located port and starboard forward on the deck. All fuel fills are labeled DIESEL.

The **waste tank pump out** fitting is located on the starboard foredeck and it is labeled WASTE. The **fresh water fill** is forward of the waste tank fitting and it is labeled WATER.



## WARNING

THE CLEATS ON THE BOW AND STERN OF YOUR BOAT HAVE NOT BEEN DESIGNED FOR, AND ARE NOT INTENDED TO BE USED FOR TOWING. USING THEM FOR THIS PURPOSE COULD RESULT IN PERSONAL INJURY AND DAMAGE TO YOUR BOAT AND OTHERS.

### 1.4 FOREDECK

The Tiara 39 foredeck, see **Figure 1-9** has two hatches connected by a skylight, a rope locker hatch, the anchor roller in the bow pulpit, an anchor cleat, two mooring cleats, red and green running lights, the bow rail with burgee staff, and remote control spotlight. Optional fresh and raw water washdown are located in the anchor locker.

The **windlass system** is operated from the foredeck foot pedals or by the remote switch at the helm. The foredeck foot pedals have stainless steel covers. Hinge back the covers before operating. See equipment manufacturer's manual for operation instructions.

### 1.5 HULL SIDES AND TRANSOM

The port and starboard hull sides each have engine room vent recesses amidships, and a number of required vents and thru-hulls.

Located on the transom of your Tiara 39 is the white stern light, recessed trim tabs, sacrificial anodes (see Section 7.4.6), boarding steps on centerline, and the engine exhausts. Near center line is a grab handle to allow easy reach to the handrail on the transom.

The **swim platform** options are a full fiberglass platform or a platform with teak inlay.

The fiberglass platform contains a recessed, folded, swim ladder under a center hatch. The ladder folds down into the water for easy boarding. To open the ladder hatch hinge it forward, open by pulling on the hand grip slots, or on the aft edge below the rub rail. When using the ladder, the hatch should be closed to allow easy reach to the handrail on the transom, the grab rail can be utilized for added safety.

## EXTERIOR



*Figure 1-9: The foredeck.*

The teak inlay platform has a swim ladder below the platform. To deploy the ladder first open the stainless door and then pull the ladder aft.

**Optional underwater lights** are available on the transom. When they are installed the switch is located on the helm.

### 1.5.1 Transom Door and Gate

To starboard, in the transom, are the transom door and gate.

The gate is secured down by a latch, on the underside, at the starboard end. The door opens inboard and is held shut by a latch on the inboard face.

## 1.6 HARDTOP

A fiberglass hardtop is available as an option on your Tiara 39, covering the command bridge area.

In order to keep the hardtop fiberglass part as light weight as possible, the laminate schedule and core material were selected to provide a part suitable for shelter from the elements, but not support the weight of people. The top side has a textured surface, but was not intended to provide a nonslip surface.



*Figure 1-10: Drink holders on the teak swim platform.*



**CAUTION**

After market installations on the swimplatform can potentially block the stern NAV light's visibility. On some models the transom door, when ajar, blocks the stern NAV light's visibility. Never run the boat with the transom door open.

**WARNING**

**DO NOT OPERATE THE VESSEL UNDER POWER WITH THE TRANSOM DOOR OR GATE OPEN. OPERATION OF BOAT WITH TRANSOM DOOR AND GATE OPEN MAY ALLOW PERSONS TO FALL OVERBOARD AND INTO BOAT PROPELLERS OR TO BE LOST IN OPEN WATER.**



**WARNING**

**DO NOT STEP ON THE HARDTOP. FAILURE TO DO SO CAN RESULT IN DAMAGE TO THE HARDTOP, AND COULD CAUSE A FALL, RESULTING IN SERIOUS PERSONAL INJURY.**



**CAUTION**

**Do not overload the hardtop. The hardtop is designed to carry typical electronic packages, antennas, and the like only. Prior to any hardtop installation consult your Tiara Yachts Dealer and or Tiara Professionals.**

## Chapter 2

# INTERIOR EQUIPMENT AND FEATURES

Optional portlights in the interior should be closed and securely dogged down when underway. When at the dock privacy covers and screens are available for the portlights and are stowed in the Master Stateroom hanging locker. To use them open the desired portlight, place the cover or screen into place and leave the portlight open. Remove the cover or screen and close the portlight when leaving the boat or when weather is foul.

## 2.1 MASTER STATEROOM

The Master Stateroom, see **Figure 2-1**, in your Tiara 39 Interior has a privacy curtain. Open the starboard side hanging locker and deploy the curtain athwartships.

Further features in the Master Stateroom include:

- Overhead cabinets run port and starboard along the hull side. Cabinet doors open from the underside.

*Figure 2-1: 3 Interior layout.*

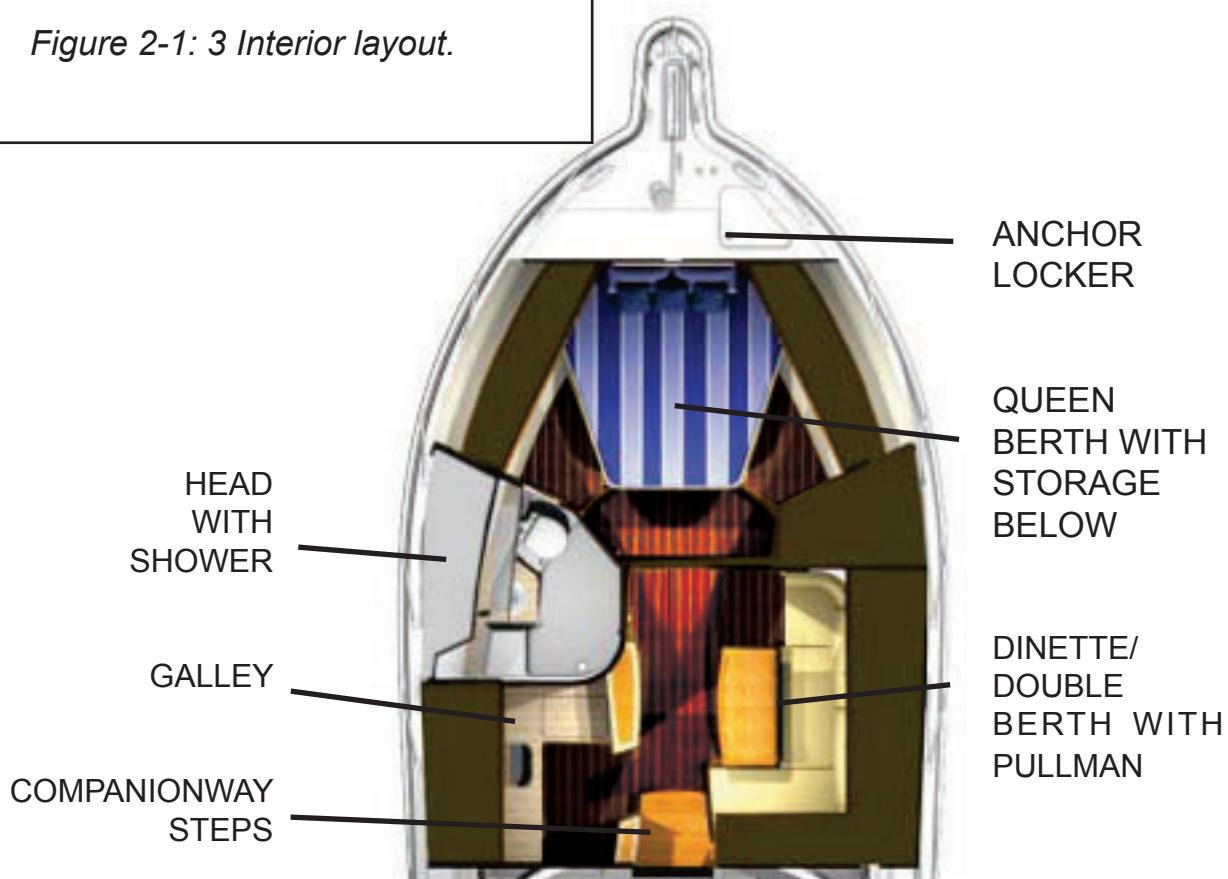

## INTERIOR

- Marine Air Systems® air conditioner with reverse cycle heat.

### Lighting:

- Rope lighting, port and starboard, below the overhead cabinets, as well as two reading lights on the forward bulkhead with built in switches.
- Switches: The soffit lighting is controlled by the middle switch on the light switch panel. The light switch panel is located to starboard of the centerline doorway.
- Natural lighting, as well as ventilation are provided by an overhead hatch and a fixed skylight. The hatch is large enough for escape in the event of an emergency. The blind and the screen are full length, pull out and across to use. They tension hold into place.

### 2.1.1 Berth

Features in the berth include:

- A convenient step on port and starboard for stepping up into the berth.
- **Queen pedestal berth** with inner spring mattress, quilt, 2 pillow shams, and 6 throw pillows.

**Storage** under the berth is both forward and aft, see **Figure 2-2**. Access the forward storage area by lifting the berth cushion, which is hinged on its aft edge. Below the cushion is a lift out hatch. Beneath the hatch is a large storage area.

The aft berth storage hatch is assisted open by two gas cylinders. The aft berth storage has a lock on the starboard side.

To open the aft berth storage:

1. Unlock by pulling aft on the lock on the starboard side of the berth.
2. Lift up on the aft end of the berth and the hatch and cushion will come up together.

Below this hatch is a large storage area with an air conditioning unit, and the optional central vacuum unit inside. On the underside of the berth hatch are two storage baskets, which are held in position by a turn button latch. There are latches

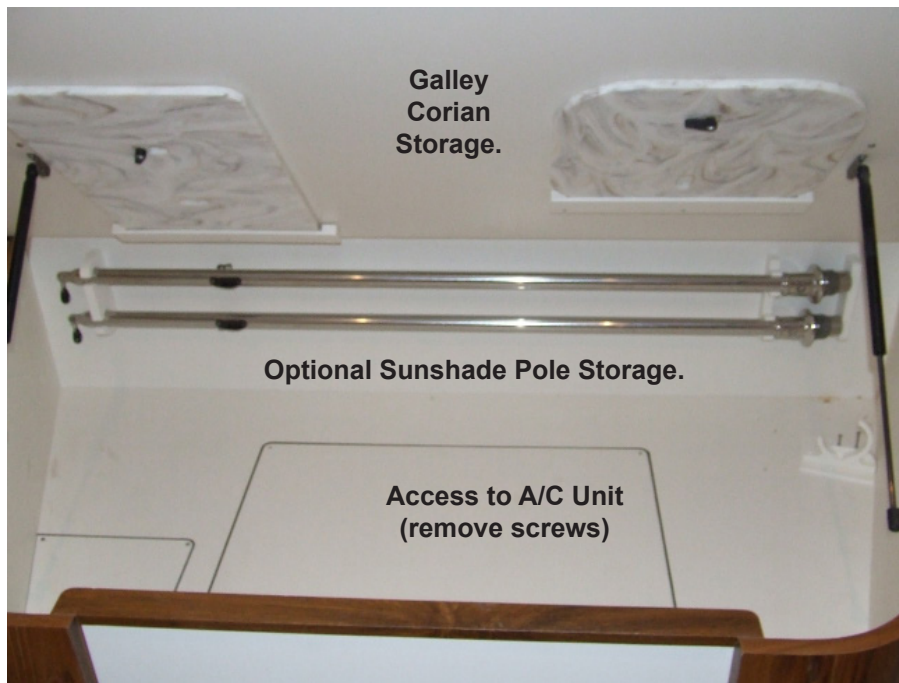

Figure 2-2: Aft berth storage.

for storage of the Corian® sink and stove lids on the underside of the berth.

### 2.1.2 Hanging Locker

To starboard is a cedar lined hanging locker, with shelf below. Lighting is provided in the locker by a courtesy light which is activated automatically when the door is open. A felt bag in the hanging locker holds port light covers and screens.

### 2.1.3 Outlets, Safety

Inside of the forward overhead cabinet is a 120V A.C. outlet. To starboard,

on the forward face of the forward stateroom bulkhead, is a carbon monoxide detector and smoke detector.

Forward of the starboard bulkhead is the air conditioning temperature control pad and the light switch. Please read the operating literature supplied by the equipment manufacturer for specific operation of the air conditioning control pad.

Optionally a TV is mounted on a stainless pole. The pole is inserted not a locking mount in the port side of the berth, see Figure 2-3, or optionally in the aft cockpit. Refer to the manufacturer’s literature for complete operating instructions.

## 2.2 CONVERTIBLE DINETTE

The dinette is located to starboard in the main salon area.

**Light switches** for the dinette are located in the starboard companionway step bulkhead. An overhead hatch near centerline provides natural lighting and ventilation. The hatch has a screen and a blind that pull across and magnetically lock into place.

## INTERIOR

A 120V outlet is on the aft dinette bulkhead.

The main salon **smoke detector** is located on the starboard dinette headliner. A **carbon monoxide detector** is next to the smoke detector.

**Storage** is provided under the dinette seat cushions. Pull out the cushions to access the storage. Optional rod storage is available below the outboard cushions. Below the aft cushion there is a screwed down hatch that allows access to the salon air conditioner and subwoofer.

The **dinette table** lowers to create a double berth. **To convert to a berth:**

1. Lift the lever on the table post, push the table top down, push the lever down to lock the position.
2. Place the additional cushion provided (in berth storage) on top of the table top.

To convert back to a dinette, reverse the procedure.

The **outboard seat back** can also become a single berth. To do so:

1. Lift up the berth back rest to a horizontal position.
2. Unsnap the support straps from the underside of the back rest and hook into the two padeyes, located fore and aft overhead.

To close, reverse the procedure.

### 2.2.1 A.C. & D.C. System Panels

On the aft bulkhead of the salon there is the A.C. System Panel (See Figure 4-2 on page 4-6) and the cabin D.C. System Panel (See Figure 4-1 on page 4-5). Please refer to Chapter 4 for details on your boat's electrical system.

### 2.2.2 Waste and Water System Monitor, Bilge Alert

The Dometic® **Tank Monitor Panel** is located in the upper hull side cabinet above the dinette, see **Figure 2-3**. This panel has lights that indicate the status of the waste tank and fresh water tank quantities. The graphic guide on the left of the panel indicates full or empty, consult manufacturer literature for complete details. When the waste tank is full do not flush the toilet until the tank is pumped out.

When the **waste tank** is full, it must be pumped out at an approved pump-out station (see Chapter 7, Routine Maintenance, Section 7.8), or pumped overboard via the optional macerator pump. Please see the literature provided by the macerator

pump manufacturer for safe operation of this pump. Pump out of waste tanks by this method is restricted in some areas.

## 2.3 HEAD

The head in your Tiara 39 is located on port aft of the master stateroom. There are head doors in the master stateroom and main salon. See the following **Figures 2-4 through 2-7** for features in the head.

### 2.3.1 Shower, Vanity, and Vacuflush® Toilet

The telephone style shower is operated by a single lever control that is located in the port bulkhead. The floor in the shower has a nonslip texture and below (under) the floor is the drain. This drain leads to the shower sump installed under the cabin floor that is controlled automatically by a float switch.

A handrail/towel bar is provided on the outboard side of the shower.

Located forward is the vanity, which includes a sink with a hot and cold water faucet. Below the sink, in the vertical face, is a hinged door which accesses a storage area. A toilet paper holder is mounted on the backside of this storage



*Figure 2-3: Inside of the upper hullside dinette cabinet. Above: the Johnson Pump is a bilge alert that sounds an alarm when water reaches a level above the bilge pumps. Refer to the manufacturers information for operation guidelines. Below: the Dometic® Tank Monitor Panel - refer to section 2.2.2 for details.*

## INTERIOR

door. Additional storage is provided outboard of the vanity behind the two hinged mirror doors.

The toilet has a flush handle on the aft underside. Refer to the manufacturer's literature for complete operation guidelines.

## 2.4 GALLEY

**Light switches** for the port side galley are located on the aft bulkhead near the 120V outlet, above the Corian® counter top. Courtesy lights are outboard of the keeper. Galley main lighting is under the cabinets and in the headliner.

*Figure 2-4: Lower vanity with Corian® countertop. Storage is below the stainless steel sink. Read the literature provided by the manufacturer of the Vacuflush® toilet for operation details. Light and exhaust fan switches are near the exhaust outlet on the forward face of the lower vanity.*



*Figure 2-5: The mirrored vanity has toggle locks on the underside of each mirror and gas shocks to assist in holding open.*





The **galley counter top** is Corian® and Corian® lids cover the sink, a large storage bin, and the stove. Please support the Corian® lids with two hands when removing. Storage for the Corian® sink and stove lids is located in the starboard hanging locker in the master stateroom. Place the lid over the either the fore or aft toggle locks. Lock when in place.



*Figure 2-6: The bifold shower doors shown in the closed underway position. The lock clamps down on the left side handle. To use the doors for showering swing the lock open, open the right side door out and forward, then the left, meet the doors together and they will magnetically bond, as shown in Figure 2-7.*



*Figure 2-7: Shower doors shown in the shower use position.*

## INTERIOR

The single lever hot and cold **faucet** is also a sprayer. An in-line **water filter** is installed to service the galley faucet. Refer to Chapter 7, pages 7-6 and 7-7 for details.

### 2.4.1 Storage

Below the sink there is a storage cabinet. A **fire extinguisher** is located inside of this cabinet.

**Overhead cabinets** in the galley are opened with toggle locks on the center underside of each cabinet. All three cabinets are supported in the open position with gas shocks.

**Storage pantries** are located behind an aft door and include inboard open shelves. Below the shelves is a pullout drawer with two garbage receptacles. Remove this drawer to access the forward fuel tank valves and associated fittings, see page 7-3 in Chapter 7.

### 2.4.2 Appliances

The galley in your Tiara 39 includes a variety of appliances. For each one, the owner's manuals from the equipment manufacturer has been included in your owner's packet. Please read these carefully before operating any appliance.

Recessed in the counter top, beneath a removable Corian® lid is the two-burner **electric stove**. When closed, the Corian® lid activates a micro switch that shuts off the stove power. This switch is provided as a secondary assurance that the heat from the stove does not cause a fire on the counter top cover.

Beneath the counter top, at the aft end of the galley are the **120V A.C. /12V D.C. refrigerator** with a separate freezer.

At the forward end of the galley, the **microwave** is located below the counter top, facing aft.

## 2.5 COMPANIONWAY

The main salon in your Tiara 39 is entered from the cockpit via the companionway steps, on centerline. A convenient handrail is provided as you come down the companionway, to starboard. The courtesy lights, located in the vertical risers between the steps, are controlled by the light switch to starboard, in the companionway. This switch also controls the overhead lights.

The **companionway door** has a **privacy cover**. When extra privacy is desired install the cover by lining up the snaps and Velcro fasteners on the cover with the fasteners on the interior side of the door frame.

The **air conditioner control** for the optional upper cockpit air conditioner are located on the port side of the companionway steps. The main cabin air conditioner control pad is located outboard of the electrical panels on starboard. Please refer to the air conditioning system manufacturer owner's manuals for specific operating instructions.

A storage area is located under the top companionway step. There are two **G.F.I. outlets** located in this area. To reset the circuit press the G.F.I. button labeled "RESET". The bottom step is held in place with screws and is removable for access to the top of the forward fuel tank plate, valves and fittings.

The **TV** is in the inboard face of the galley peninsula. Below the TV is the **DVD player**. The speakers are below the TV. Consult manufacturer literature for operation instructions. Below the DVD shelf there are audio video inputs, see **Figure 2-8**.

Centerline, just inboard of the head, is a floor hatch. Inside is access to the water tank.

### 2.5.1 Remote Control Lighting System

Your Tiara 39 comes equipped with a remote control lighting system.

When approaching the boat from the dock, the supplied wireless remote control will activate the cockpit courtesy lights. The cockpit lights will remain on until turned off via the remote control. The wireless control has a range of approximately 25 feet dependent on local electronic interference. For this system to operate, the remote control lights breaker must be ON. The breaker is located on the D.C. System Panel.



## CAUTION

**Do not close the countertop stove cover until the burners are cool. Failure to do so could result in damage to the cover, stove, or both.**

## INTERIOR

### 2.6 CARBON MONOXIDE MONITORING

If excess carbon monoxide fumes are detected, an audible beeping will sound indicating the presence of the toxic gas.

Please read the owner's manual supplied by the detector manufacturer for operation instructions and additional information on the hazards of carbon monoxide gas.



*Figure 2-8: Audio video inputs located in the cabinet below the TV.*



**WARNING**

THE CARBON MONOXIDE MONITORING SYSTEM IS ONLY A SUPPLEMENTAL SAFETY AID. MAKE SURE YOU FOLLOW ALL SAFETY PROCEDURES GIVEN IN THIS MANUAL. CARBON MONOXIDE IS A LETHAL, TOXIC GAS THAT WILL CAUSE DEATH IN CERTAIN LEVELS.

This page intentionally left blank.

## Chapter 3

# ENGINE ROOM

---

### 3.1 GENERAL ARRANGEMENT

The engine room of your Tiara 39 is entered through a hatch in the upper cockpit floor, on centerline or the upper cockpit floor lifts to access the engine room for service. The engines are located to port and starboard as you stand on centerline, the marine gears, or transmissions, are at the aft end of the engines.

A general description of some of the engine room's components is reviewed here, for your information and awareness. Your Yachts dealer can also provide you with specific information on any system or component in your boat.

For maintenance of any system in the engine room, please refer to Chapter 7 in this manual, the owners manuals provided by the component manufacturers, or your authorized Tiara Yachts dealer.



#### **CAUTION**

**The swivel seat must be in its aft most position when lifting the large engine hatch.**



#### **CAUTION**

**The optional drop curtain, and starboard side curtain enclosure must be unzipped before actuating (opening) the large engine hatch.**



#### **CAUTION**

**Engines and equipment in the engine room may be hot to the touch and might burn your skin. Care must be taken to avoid these areas while in the engine room.**

## ENGINE ROOM



*Figure 3-1: Centerline looking forward.*



*Figure 3-2: Engine raw water seacocks and strainers.*

### 3.1.1 Centerline

#### **Centerline Forward:**

The fuel water separators, Fireboy fire suppression system bottle, (see **Figure 3-1**) are on the forward engine room bulkhead.

The engine raw water strainers and seacocks are located on the engine room floor, see **Figure 3-2**. Optional bilge crash pumps are available and installed aft of the raw water seacocks. The bilge crash pumps are used in an emergency to vacate the engine room bilge of any water intrusion. To operate the bilge crash pumps open the seacocks on the crash pumps, see **Figure 3-3**, and close or restrict the water flow to the engine seacocks. This will allow the engines to dispose of the intrusion water overboard. Reverse the procedure when the intrusion water is no longer present.

#### **Centerline Aft:**

Between the engines is a removable floor. Below is the waste tank. Aft of the waste tank is the optional generator.

### 3.1.2 Starboard

The oil changer is aft of the starboard engine (see **Figure 3-4**). Please refer to the manufacturer's literature for operation instructions.

Outboard of the engines are the engine room hull side air intake plenums. The plenums are designed



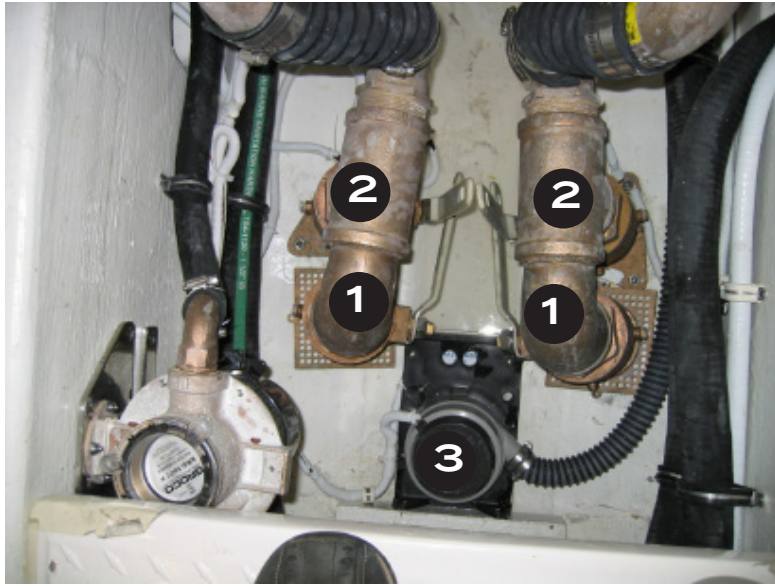

*Figure 3-3: Centerline between the inboard stringers on the engine room floor: 1. Optional Bilge Crash Pumps; 2. Engine Raw Water Seacocks; 3. Engine Room Bilge Pump.*

to allow fresh air into the engine room for ventilation and engine air, while separating out sea water and draining it overboard.

Below the starboard plenum is the storage bucket for the aft 50A, 240V shore power cable, see **Figure 3-5**).

Forward of the starboard engine installed on the forward bulkhead are the battery charger and the horn compressor, see **Figure 3-6**.

The engine battery bank is outboard of the starboard engine. Please see section 7.3.1 for their care and maintenance.

### 3.1.3 Port

Outboard of the engines, is the port engine room hull side air intake plenum. The water heater is forward on port. Aft of the water heater is the house battery bank. Please see section 7.3.1 for their care and maintenance. Refer to the Figures 3-7 through 3-9 for port side installations.



*Figure 3-4: Aft of the starboard engine. From left to right: power assist steering pump, oil changer, and the starboard engine coolant recovery tank.*

## ENGINE ROOM



**!** **WARNING**

**FUEL VAPORS ARE A FIRE AND EXPLOSION HAZARD THAT CAN RESULT IN SERIOUS INJURY, BURNS, OR DEATH. DO NOT STORE CONTAINERS OF FUEL OR OTHER FLAMMABLE LIQUIDS IN THE ENGINE ROOM COMPARTMENT.**

*Figure 3-5: Storage bucket for the aft 50A, 240V shore power cable, outboard on starboard.*



*Figure 3-6: Starboard side forward engine room bulkhead. Battery charger (left), Horn compressor (right).*



## WARNING

**A WIDE VARIETY OF COMPONENTS USED ON THIS VESSEL CONTAIN OR EMIT CHEMICALS KNOWN TO THE STATE OF CALIFORNIA TO CAUSE CANCER AND BIRTH DEFECTS AND OTHER REPRODUCTIVE HARM.**

**EXAMPLES INCLUDE:**

- Engine and generator exhaust.
- Engine and generator fuel, and other liquids such as coolants, oil, and especially used motor oil.
- Cooking fuels.
- Cleaners, paints, and substances used for vessel repair.
- Waste materials that result from wear of vessel components.
- Lead from battery terminals and from other sources such as ballast or fishing sinkers.

**TO AVOID HARM:**

- Keep away from engine, generator, and cooking fuel exhaust fumes.
- Wash areas thoroughly with soap and water after handling the substances above.



*Figure 3-7: Water heater on port.*

## ENGINE ROOM



*Figure 3-9: Aft of the port engine. Generator fuel filter (left).*

## Chapter 4

# ELECTRICAL SYSTEMS

---

### 4.1 GENERAL

The electrical systems in your Tiara 39 have been designed and built to the recommendations of the American Boat and Yacht Council (ABYC), the requirements of the United States Coast Guard, and have received National Marine Manufacturers Association (NMMA) Yacht Certification. It has been developed to supply all the boat's electrical needs at the dock, at anchor, and underway. While we are not attempting to describe all of the electrical engineering that went into the system, we believe some understanding of the basics of its operation would help assure trouble free operation.

All of the electrical functions on your boat are a part of three basic systems, 12V D.C., 120/240V A.C., and bonding.



### **WARNING**

**ALL SERVICE WORK ON THE ELECTRICAL SYSTEMS IN YOUR TIARA 39 SHOULD ONLY BE PERFORMED BY YOUR TIARA YACHTS DEALER, OR OTHER AUTHORIZED MARINE ELECTRICAL SERVICE FACILITY.**

### 4.2 12V D.C. SYSTEM

#### 4.2.1 Power supply

Power is supplied to the 12V D.C. system from two banks of batteries, an engine bank, and a house bank. Each bank is comprised of wet flooded cell batteries connected together to form a bank. Boats equipped with the optional D.C. to A.C. inverter will have the number of batteries in the house bank increased to four, to manage the increased loads possible from inverter usage.

The intent of your 12V D.C. system design is to provide a source of the basic needed battery power to operate your vessel safely while underway, and a second source for convenience and comfort items. It is expected that the engine

## ELECTRICAL SYSTEMS

bank will provide the basic operating power, and that the house bank will provide the convenience and comfort power, as well as power for other owner installed convenience items and electronics. It is important that the engine bank load be carefully determined so as to never result in a condition where the boat will not be able to be started, and operated safely in any weather or sea condition.

Battery power is replenished in two ways. First, from the engine installed alternators. The port engine alternator charges the engine battery bank. The starboard engine alternator charges the house bank. This charging takes place whenever the engines are running.



### CAUTION

**All owner installed items should be installed by your TIARA dealer, or other authorized marine electrical service facility. They must only be installed to be powered from the house battery bank.**

The second source of battery bank charging comes from the 120V A.C. battery charger. For this to operate the boat must be connected to shore power, or have the generator running and powering the 120V A.C. System panel (see **Figure 4-2**) in the cabin (see Section 4.3.1). The battery charger breaker on the 120V A.C. System Panel must also be in the ON position (see **Figure 4-2**).

It is important that your batteries be kept in a state of full charge as often as possible. Fully charged batteries will indicate a voltage in excess of 12.6 volts with no load, or while being charged. Prolonged periods of discharge below 12.2 volts (indicated with no load on the bank) will cause the batteries to deteriorate rapidly, and will result in their inability to hold a charge for the expected amount of time. This can happen easily if your boat is left unattended for an extended period of time, has D.C. loads on, such as lights, and the battery charger is not left ON.

### 4.2.2 Wet Flooded Cell Batteries

Wet flooded cell batteries are the source of electrical power on your Tiara 39. These batteries require periodic maintenance. In warmer climates, the electrolyte should be checked on a monthly basis. In cooler climates, the electrolyte can be monitored less frequently. The battery cells are covered with a round screw-in top. Unscrew each top to inspect each cell. Each cell of the group 31, wet flooded cell, deep cycle battery contains lead plates. If a maintenance inspection finds low electrolyte, in which the lead plates are visible, it is necessary to fill each low cell

with **distilled water** so that the lead plates are no longer visible. The cells should not be filled to the top. If the cells are overfilled its possible that during charging the electrolyte could boil over and cause damage to the battery or surrounding equipment, therefore, it is necessary to only fill the cells just over the lead plates, leaving an air space between the distilled water electrolyte and the cap. If upon inspection the lead plates are not visible, the cell is filled to specification.

### 4.2.3 Distribution

Power from both battery banks supplies the 12V D.C. System Panel, located on the aft dinette bulkhead (see **Figure 4-1**). Power from the engine bank is connected to the Engine Battery Bank switch, and power from the house bank is connected to the House Battery Bank switch. When these switches are in the OFF position, all D.C. power to the boat is cut off, with an exception:

**Note:** Power is supplied to: the forward, mid, and aft automatic bilge pumps, the stereo memory - before the main disconnect switches. The main disconnect switches will not disconnect power to those items.

The Battery Bank Interconnect switch is provided to cross connect the powered side of both battery banks. This switch should only be used (turned ON) in conditions such as those described in Section 4.2.4. Otherwise, it should remain in the OFF position.

An optional inverter switch is located under the steps. To use the inverter the optional inverter switch must be switched ON.



## CAUTION

The engine room lights are turned ON by the Engine Room Lights breaker switch on the DC Distribution panel. There is no specific switch elsewhere on the vessel.



## CAUTION

Turn ON the optional Washdown Pump breaker when there is a need to use the raw water washdown. The washdown pump pressure switch turns ON the pump when the spray nozzle is opened. Turn breaker OFF when not in use.

## ELECTRICAL SYSTEMS

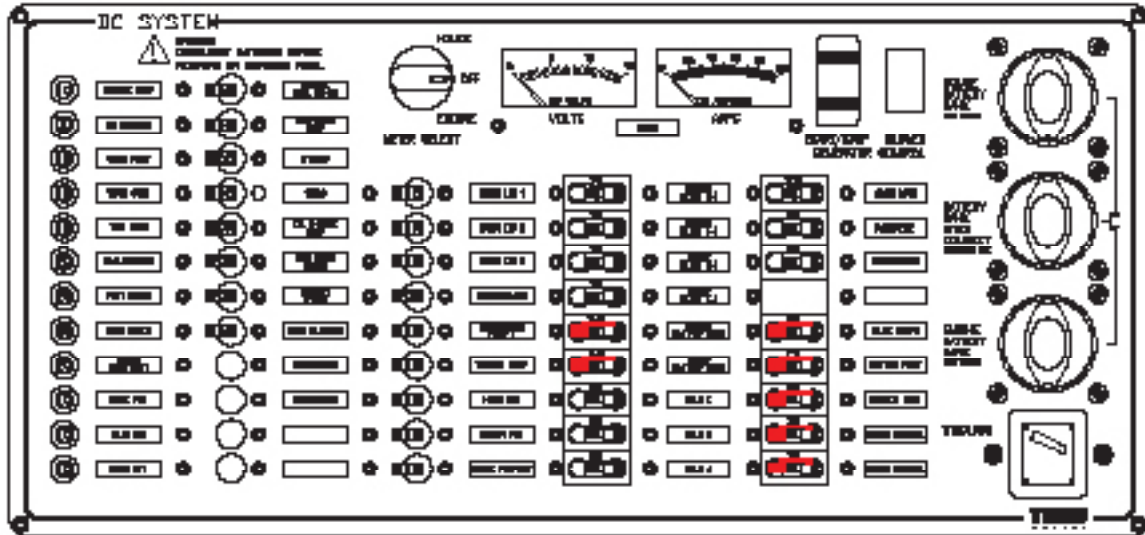

Figure 4-1: D.C. System Panel.

From the Engine and House battery bank switches power is distributed to the Helm Breaker Panel (behind the console), and D.C. System Panel or directly to a D.C. component. Power to all D.C. components is further distributed from these panels. For information on which circuit powers which components, please refer to the wiring schematics provided in Appendix C, and the comments under Section 4.2.4, Operating Notes.

### 4.2.4 Operating Notes

As mentioned in Section 4.2.3, the Battery Bank Interconnect switch has been provided for use in certain conditions.

The conditions under which the Battery Bank Interconnect switch should be used are:

1. Long term trolling on one engine, with the other engine not operating. When one engine is not operating, the associated engine battery it charges is not taking a charge. Operational loads on this bank will gradually reduce its capacity, and could do so to the point where critical operational and safety items do not operate as expected. The engines may also be difficult to start, even with the battery parallel feature. Use of the Battery Bank Interconnect switch will



allow one running engine to charge both battery banks. Charging of the engine bank can also be accomplished via the 120V A.C. battery charger, if power is available from the on board generator. Careful monitoring of battery bank voltages is advised while using this switch, to detect abnormal battery bank conditions early.

2. Failure of one battery bank. In this condition, some circumstance has caused the failure of one battery bank so that it can no longer supply any power to the components. To power all loads from one battery bank you must first turn the failed bank's switch to the OFF position (starboard engine charges the house battery bank and the port engine charges the engine battery bank), and then turn the Battery Bank Interconnect connect switch to the ON position. All D.C. components will now be powered from the good battery bank.

When leaving the boat for any extended period, turn the Engine and House Battery Bank switches OFF on the D.C. System Panel (see Figure 4-1). You should also leave the boat connected to shore power with the 120V A.C. battery charger ON. Turning off the Engine and House Battery Bank switches also disables power to the helm, preventing operation of the engines and other helm functions. If you are leaving the boat for a shorter period of time and wish to keep D.C. power supplied to other components, switching the Ignition breakers on the 12V D.C. System Panel (see Figure 4-1) to the OFF position will prevent the engines from being operated.

Engine control breakers on the D.C. System are on lock out switches. These should never be turned OFF, unless servicing the engines.

When you first arrive at your boat for a trip, and periodically when using your boat, it is a good idea to monitor your battery voltages. Battery voltages below 11.5 volts (with a load on the bank) indicate a problem condition preventing battery replenishment. Investigate and correct low voltage indications immediately.

### 4.2.5 12V D.C. Power

On the port side shroud 12V D.C. power is available. The breaker is on the Helm Breaker Panel located behind the console (See **Figure 4-2**), see page 1-6 in Chapter 1 for further detail regarding the Helm Breaker Panel.

## 4.3 120 / 240V A.C. SYSTEM

### 4.3.1 Power Supplies

A.C. power is supplied to the A.C. cabin panel in 4 ways:

1. Connecting to 120V/240V 50A dockside power via the dockside inlet with recoil (see Section 1.2.1 for hookup directions).
  2. Running the on board generator.
  3. Using the optional inverter from the house battery bank.
- **Note:** High power A.C. appli-



Figure 4-2: Helm Breaker Panel. behind the console.



## WARNING

WHEN OPERATING ALL D.C. LOADS FROM ONE BATTERY BANK, ALL NON-ESSENTIAL LOADS SHOULD BE DISCONTINUED UNTIL THE PROBLEM WITH THE FAILED BANK IS CORRECTED, AND TWO BATTERY BANKS ARE AVAILABLE FOR USE AGAIN. FAILURE TO DO SO CAN RESULT IN RAPID DEPLETION OF BATTERY CAPACITY NEEDED TO SAFELY OPERATE THE BOAT, AND PUT THE BOAT AND PERSONS ON BOARD IN JEOPARDY.

ances such as the stove, air conditioning, and water heater cannot be powered from the inverter.

### 4.3.2 Distribution

Power from the generator and shore power cord are supplied to the A.C. System Panel (see **Figure 4-3**). The system is designed so that only one source can be selected at a time.

Power is supplied from the selected main breaker to the individual circuits via the circuit breakers in the panel. For a description of the individual circuits, and which components they supply, please refer to the wiring schematics in Appendix D.

**Note:** Below the top companionway step are two blind ground fault circuit interrupters (G.F.C.I.). If a circuit loses power check the G.F.C.I. first before checking the breaker on the A.C. System Panel. To reset the circuit at the G.F.C.I. press the button labeled “RESET”.



### CAUTION

**Operating your A.C. electrical system with low, or high, voltage may damage some on-board A.C. electrical appliances.**

#### 4.3.3 Operating Notes

The greatest amount of A.C. power is available when connected to 240V 50A shore power, or the on board generator. If too much load is applied when connected to 120V 30A shore power via the pigtail, it is possible to trip the dockside breaker. This should not happen while connected to 240V 50A shore power, or while running the generator, unless extraordinary A.C. loads are applied via the 120V outlets in the cabin, cockpit.

When using A.C. power, it is a good idea to monitor the voltage available, and load applied, periodically, to detect abnormal operating conditions early. The volt meter will indicate the voltage of that source and the amp meter will indicate the current load being applied to that source. If voltage supplied is lower than 105V or higher than 130V for the 120V 30A power, or lower than 210V or higher than 260V for the 240V 50A power, discontinue use and correct the problem as soon as possible.

To power circuits from the optional inverter, turn all A.C. shore main breakers on the A.C. System Panel to the OFF position and turn the inverter ON from the inverter system panel (located in the dinette overhead cabinet). The inverter switch, near the inverter, must also be in the ON position. Whenever A.C. power is available from shore or the generator, the inverter automatically stops supplying A.C. power from the batteries. For specific operating instructions, please refer to the owner’s manual supplied from the inverter manufacturer.

## ELECTRICAL SYSTEMS

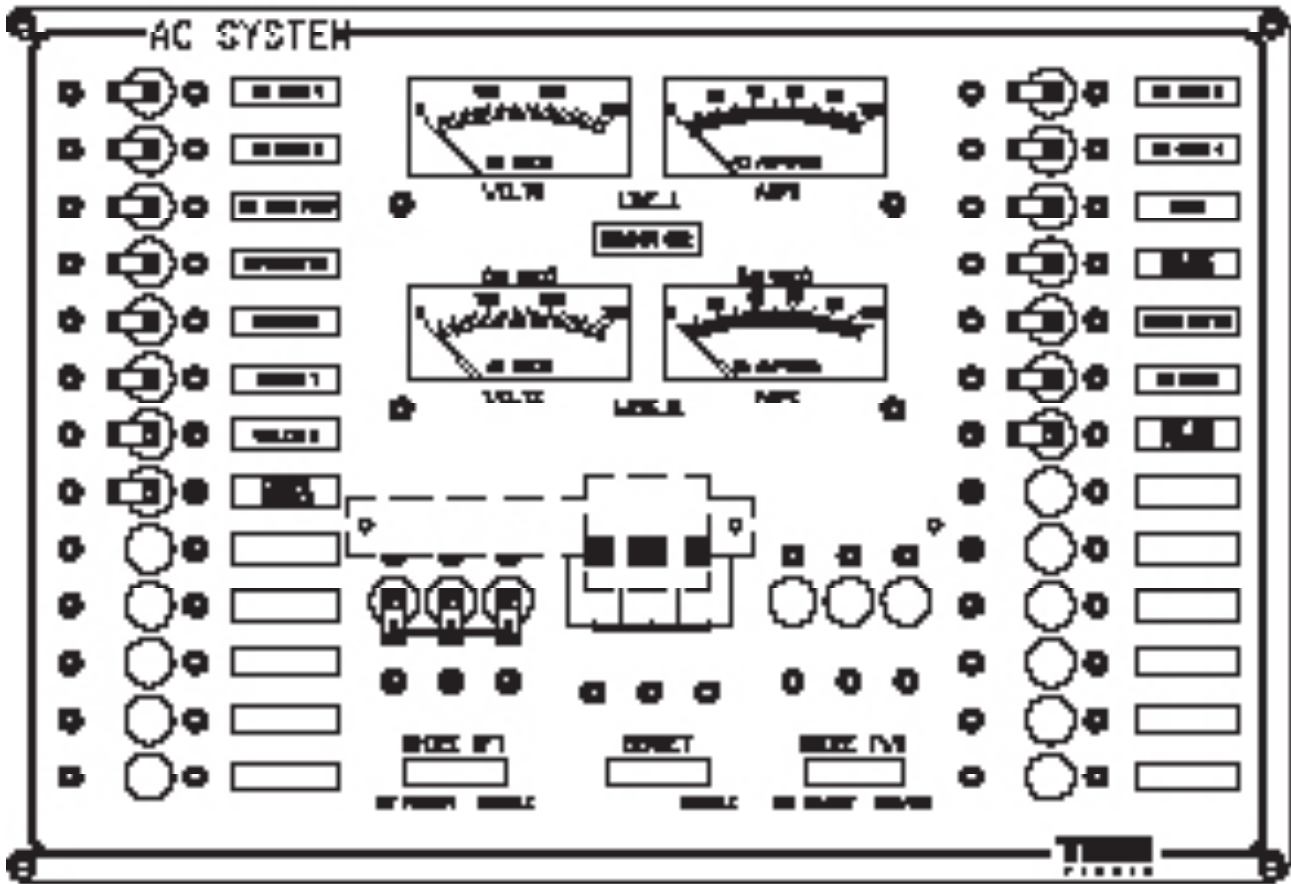

Figure 4-3: A.C. System Panel.

## 4.4 BONDING SYSTEM

The purpose of the bonding system on your boat is to provide a low resistance electrical path between otherwise isolated metallic objects, particularly those in common contact with sea water and potentially subject to galvanic corrosion.

The bonding system is connected to two large zincs mounted to the transom of your boat. These zincs are provided to purposely deteriorate over time, to assure that the other components do not. These zincs must be checked periodically to determine their status and be replaced when they become depleted by 50% or more. Zincs are also provided on the propeller shafts, as the shafts are not connected to the bonding system and made of stainless steel. The trim tabs are connected to the bonding system and they also have zincs for added protection. These zincs must also be checked periodically and replaced as necessary.

## ELECTRICAL SYSTEMS

Owner installed components that are below the waterline must also be connected to the bonding system. Comparable wire sizes and terminals must be used, and should be connected directly to the nearest bonding system terminal strip. Failure to do so may result in severe galvanic corrosion of the item and possible premature failure, resulting in a water leak.

The bonding system is connected to the main D.C. ground bus along with the A.C. ground bus. This establishes the water as ground potential and helps prevent the existence of electrical potential on exposed metallic hardware and electrical equipment.



**WARNING**

THE A.C. GROUNDING BUSS MUST REMAIN CONNECTED TO THE MAIN D.C. GROUND BUSS AT ALL TIMES. DO NOT CUT THE GREEN WIRE IN THE SHORE POWER CORD, OR RELATED EQUIPMENT. TO DO SO CAN CAUSE LETHAL VOLTAGE TO BE PRESENT ON BOAT EQUIPMENT, OR IN THE WATER AROUND THE BOAT.



**CAUTION**

Owner installed components that are below the waterline must also be connected to the bonding system. Comparable wire sizes and terminals must be used, and should be connected directly to the nearest bonding system terminal strip. Failure to do so may result in severe galvanic corrosion of the item, and possible premature failure, resulting in a water leak.

## Chapter 5

# OPERATING YOUR BOAT

---

### 5.1 WHEN ARRIVING AT YOUR BOAT

When you arrive at your boat to take a trip, the first thing you should do is go below and turn ON the 12V D.C. main battery switches, and necessary breakers on the D.C. System Panel (under the companionway steps). Also turn ON any necessary A.C. breakers on the A.C. System Panel (also under the companionway steps). This will allow you to operate any equipment you might need. From the D.C. System Panel, check the condition of your batteries with the battery monitor system. If the battery(s) reads below 10.5 volts with a load on it, or below 11.5 volts with no loads, investigate the D.C. system for the cause.

The second thing that you should do is check the bilge areas of your boat, forward, aft, and in the engine room, for unexpected water or debris. While doing this, it's a good time to check and open any seacocks for equipment that may have been shut off when you last left your boat. While in the engine room, you should check the engine oil, engine coolant, transmission oil, generator oil, and coolant. Also, smell for any fuel fumes or other unusual smells and investigate if detected.

While at the helm area, check to see that all equipment is functioning by testing each one with its switch.

#### 5.1.1 Connecting to Shore Power

**How to connect to 240V 50A shore power:**

1. On the A.C. System Panel switch the Shore Aft (or optional Shore FWD) breaker to the OFF position.
2. Extend the shore power cord by opening the cover over the cord. Flip the cablemaster switch to the OUT position. The cablemaster switch is near the shore power cord cover. When sufficient cable is extended to reach the shore power station return the cablemaster switch to the neutral or center position.

Again, when routing electric cables from the boat to the dock, be sure to allow sufficient slack so that as the boat moves within its slip, the cables and hoses are not strained in any way. Never allow the shore power cord to dangle in the water.

3. Plug the cord into the dockside power outlet.

## OPERATING YOUR BOAT

4. Turn ON the dockside power station breakers.
5. Turn ON the A.C. System Panel shore power breaker.
6. Be sure that the input status light for the Shore Aft or Fwd is ON (illuminated). This light is labeled “AVAIL” and is green.

To disconnect 240V shore power:

1. Turn OFF the A.C. System Panel shore power breaker.
2. Turn OFF the dock breaker.
3. Disconnect the shore power cord from dock outlet.
4. Return the cord to the boat cockpit and carefully retract the cable by flipping the cablemaster switch to IN. When fully retracted toggle the cablemaster switch to the neutral or center position and replace cover.

As an option 240V 50A forward shore power is available. When installed it is located in the anchor locker. The connection procedure is the same except that the 240V 50A cord has no power retractor and must be extended and retracted manually.

### 5.1.2 Fueling Your Boat

The aft fuel tank fuel fills are located port and starboard near the cockpit steps. The forward fuel tank fuel fills are located port and starboard forward on the deck. All fuel fills are labeled DIESEL, see **Figure 5-1**.

To fill the fuel tank follow this procedure:



## CAUTION

**When routing electric cables and dock side water hoses from the boat to the dock, be sure to allow sufficient slack so that as the boat moves within its slip, the cables are not strained in any way. Do not allow the cord to dangle into the water.**



**WARNING**

**TO REDUCE THE RISK OF ELECTROCUTION AND OTHER INJURY FROM ELECTRICAL SHOCK, DO NOT MAKE UNNECESSARY CONNECTION IN WET WEATHER, WITH WET HANDS, WITH WET CABLES AND CONNECTIONS. ALWAYS USE A 3-WIRE ELECTRICAL SYSTEM CONNECTED TO A GROUND. DO NOT USE WORN OR DAMAGED CABLES.**

1. Turn off all switches on the A.C. and D.C. System Panels so that any equipment that can make sparks can not run.
2. If your boat is equipped with a generator, make sure the generator switch is in the OFF position.
3. Make sure that your boat is securely moored.
4. Close all port lights, hatches and doors.



*Figure 5-1: Fuel Fill.*

## OPERATING YOUR BOAT

5. Estimate how much fuel is needed to fill the tanks.
6. Using the special key provided for this purpose, insert the key into the slot in the fuel fill, turn the key counterclockwise, and remove the cap.
7. Insert the fuel nozzle into the fuel fill and dispense the fuel until the tank is full. Verify that the tank is full by reading the fuel gauge and/or by the sound of the fuel fill filling up. If your tank takes significantly more fuel than expected, investigate the cause immediately.
8. Remove the nozzle and replace the fuel fill cap. Tighten securely with the provided key.
10. Check the engine room and bilge areas for fuel odors. If you smell

	<b>WARNING</b>
<b>BE SURE THAT THE FUEL FILL IS IN CONTACT WITH THE FUEL NOZZLE TO PREVENT ANY STATIC SPARKS DURING THE FUELING OPERATION.</b>	

fuel, do not start the engines or other electrical equipment. Investigate the cause, correct, and completely ventilate the bilge area before proceeding.

### 5.1.3 Fuel System

Below the aft floor hatch in the lower cockpit floor is the top of the aft fuel tank, hoses, fittings, and valves. When a valve is closed it is perpendicular to its associated hose and fittings. When a valve is open it is parallel to its associated hose and fittings. The forward fuel tank has the same access located, see page 7-3 in Chapter 7 for access directions.

### 5.1.4 Filling Your Water Tank

The fill fitting for the water tank is located on the port side deck, near the helm area. To fill the water tank:

1. Open fill fitting with special key provided.
2. Insert hose from dockside water supply and turn on.



**CAUTION**

Be careful not to spill any fuel outside the boat into the water. If you do, clean up the fuel immediately in the manner prescribed by your local regulations.



**WARNING**

FUEL IS FLAMMABLE. NO SMOKING. NEVER FILL THE TANK WHILE THE ENGINES, BLOWERS, GENERATOR, OR OTHER EQUIPMENT IS OPERATING. DO NOT FILL NEAR OPEN FLAMES.



**CAUTION**

To prevent damage to your fuel system, use only a good grade of fuel as recommended by the engine manufacturer. Do not use a fuel which contains harsh additives or alcohol. Damage done to your fuel system as a result of using these fuels will not be covered by your warranty.



**CAUTION**

Be careful to not spill any fuel on the boat. If you do, be sure to clean up any spilled fuel immediately.

## OPERATING YOUR BOAT

3. Stop filling when water overflows fitting and comes out of the vent fitting on the hull side below the fill fitting.
4. Replace cap and tighten.

### 5.1.5 Starting Your Engines

Before starting your engines, be sure that you have performed all the maintenance and safety checks listed under Section 5.1, When Arriving at Your Boat.

After performing the above mentioned maintenance and safety checks, proceed as follows to start your specific engine option:

#### Starting Cummins® Engines With Electronic Controls:

1. Open all hatches to the bilge area. Investigate and remedy any fuel vapors that are detected.
2. The aft fuel tank fuel fills are located port and starboard near the cockpit steps. The forward fuel tank fuel fills are located port and starboard forward on the deck. Make sure all fuel valves are in the open position before starting. Fuel valves are open when the valve is parallel to its associated fittings and hoses.
3. Make sure that the engine clutch levers are in the neutral position, straight up and down.

**Note:** For the procedure on how to drain the muffler see Chapter 8, Storing and Winterizing, Section 8.6.2.

4. Turn the port engine key to the START position and release when engine starts. If the engine battery bank is low on voltage, press



## WARNING

**DO NOT START THE ENGINES UNTIL YOU ARE SURE THERE ARE NO FUEL FUMES IN THE BILGE OR ENGINE COMPARTMENT OF YOUR BOAT. FUEL VAPORS ARE EXPLOSIVE AND MAY IGNITE DURING ENGINE START-UP CAUSING SERIOUS INJURY OR DEATH.**

and hold the battery parallel switch, located below the port and starboard ignitions, during the cranking operation.

5. Repeat for the starboard engine.
5. The volt meter should read between 12 and 14 volts. If the reading is below 8, or above 16, stop the engines and investigate the cause before proceeding.
6. Let the engines run at idle several minutes, before leaving the slip.



**CAUTION**

To reduce the risk of fire, investigate all fuel odors immediately and do not start the engines, or other electrical equipment.



**CAUTION**

If engines fail to start after 70 seconds of cranking, cease cranking operation. Before attempting to crank engines again, the water must be drained from the muffler. Failure to do so could result in raw water contamination of the engines' cylinders.



**CAUTION**

A no spill vent system is used so that fuel will not spill out of the vents when filling, however, fuel will exit the fuel fill pipe if overfilling occurs. When filling the fuel tanks listen carefully for a filling fuel pipe.

### 5.1.6 Throttle Operations

The standard engine throttle controls are starboard of the helm. The throttle handles (port handle for port engine, starboard handle for starboard engine) are vertical when the engine transmissions are in neutral. The engines are shifted into forward by pushing the throttle handles forward from vertical and are shifted into reverse by pulling the handles aft from vertical. When shifting from forward to reverse, or vice versa, you should pause momentarily at neutral. Shifting forward engages the engines in forward gear and speed is increased the further forward the throttle is advanced. Shifting aft from neutral engages the reverse gears and backs the boat down

### 5.1.7 Starting the Generator

Check the generator manufacturer's owner's manual for starting instructions. The generator control panel is located on the D.C. System Panel, in the cabin. The aft fuel tank fuel fills are located port and starboard near the cockpit steps. The forward fuel tank fuel fills are located port and starboard forward on the deck. Make sure all fuel valves are in the open position before starting. Fuel valves are open when the valve is parallel to its associated fittings and hoses.

To Start:

1. Press and hold the generator START switch.
2. A red light will blink as the generator prepares to start.
3. A green light on the switch will illuminate when the generator starts.
4. Release the switch when the generator starts.

To Stop:

1. Press the generator stop switch on the D.C. System panel.

Fuel is supplied to the generator from the aft fuel tank. The fuel withdrawal tube is designed for the generator to run out of fuel at a quarter (1/4) tank of fuel with the boat sitting at rest. Cruising attitudes and sea conditions may affect when this occurs. The system was designed in this manner to allow for a margin of safety so the generator does not run the engines out of fuel.

**CAUTION**

If the generator fails to start after 70 seconds of cranking, cease cranking operation. Before attempting to crank engines again, the water must be drained from the muffler. Failure to do so could result in raw water contamination of the engines' cylinders.

**5.2 LEAVING AND RETURNING TO THE DOCK****WARNING**

**THE SAME PRECAUTIONS REGARDING FUEL VAPORS FOLLOWED DURING MAIN ENGINE START-UP SHOULD BE TAKEN WHEN STARTING YOUR GENERATOR.**

Before leaving on a short cruise or an extended trip, you should leave information regarding your trip with someone who will be staying ashore. Particularly information regarding who is aboard, where you intend to cruise, and when you plan to return. This information will be extremely valuable should you run into trouble while away from the dock.

Before you cast off, be certain that you have planned your trip so that you know when to expect to need fuel and where you will purchase it. Fuel docks are not always as convenient as gas stations on the road! You should also do a last minute double check to see that all necessary safety items are on board, especially a Coast Guard approved life vest, of the proper size, for everyone on board.

Specific procedures as to the maneuvers needed to leave the dock and return to the dock smoothly vary with each situation. Information on the best procedures can be found in Chapman's (see Glossary), and through safe boating classes offered in your area, through the Coast Guard Auxiliary and the Power Squadron. For information on the courses offered in your area, call the "Boating Course Hotline" at 1-800-336-2628.

**Note:** Refer to Section 1.1.2 for specific information on your engine controls.

## OPERATING YOUR BOAT

While maneuvering around the dock, have all guests on board remain in the cockpit, or cabin areas, if they are not involved in the handling of mooring lines.

### 5.3 WHILE UNDERWAY

As the skipper of your boat, everyone on board is your responsibility. Their safety and enjoyment of the trip depends on your ability to operate your boat properly. You must stay aware of the weather and sea conditions, surrounding boating traffic, navigation of area waters and the condition of your boat and its equipment and engines.

When operating your boat at night, or when visibility is significantly reduced, you should display the proper running lights. For specific information on which lights and signals are needed for different conditions, refer to information in Chapman's or from the Coast Guard.

**Remember:**

- 1. Alcohol severely reduces the ability to react to several different signals at once.**
- 2. Alcohol makes it difficult to correctly judge speed and distance, or track moving objects.**
- 3. Alcohol reduces night vision and the ability to distinguish red from green.**

You must also keep a watchful eye on the wake that your boat produces when underway. When boating around, or near, docks and seawalls, it is important to operate near idle RPM's in order to minimize your boat's wake. Most local governments hold you responsible for damage caused by your boat's wake. When



## **WARNING**

**DO NOT OPERATE YOUR BOAT WHILE UNDER THE INFLUENCE OF ALCOHOL. THIS MAY CAUSE SERIOUS PERSONAL INJURY, PROPERTY DAMAGE, AND/OR DEATH. SMART SKIPPER'S STAY SOBER!**



boating around smaller craft you must also control the size of your wake in order to avoid capsizing the smaller vessel.

Please also keep in mind that your engines produce both noise and exhaust gas emissions. While your boat is equipped with the latest in diesel engine technology, and has an excellent exhaust system muffler, it still emits noise and gasses that may be an annoyance to your fellow boaters, or people on shore. As the operator you are responsible for these factors and must consider them when operating your boat.

### 5.3.1 Waste Disposal

While away from the dock, it is important that you endeavor to preserve our natural resources and maintain our waterways by properly disposing of all trash. The federal government has mandated:

1. It is illegal to dump plastic trash anywhere in the ocean or navigable waters of the United States. It is also illegal to discharge garbage in the navigable waters of the United States, including inland waters as well as anywhere in the Great Lakes. The discharge of other types of garbage is permitted outside of specific distances offshore as determined by the nature of that garbage.
2. The discharge of dunnage, lining, and packing materials that float is prohibited within 25 nautical miles from the nearest land.
3. Other unground garbage may be discharged beyond 12 nautical miles from the nearest land.
4. Other garbage ground to less than one inch may be discharged beyond three nautical miles of the nearest land.

Any person who violates the above requirements is liable for a civil penalty of up to \$25,000, a fine of up to \$50,000 and imprisonment for up to five years for each violation. Regional, state and local restrictions on garbage discharges also may apply. Consult the literature published by the United States Coast Guard, or understand the regulations mandated by the official maritime agency in the region you are boating within.

### 5.3.2 Anchoring

Anchoring your boat while away from the dock is possible by using the anchor and anchor line provided for this purpose. The standard boat has an anchor

## OPERATING YOUR BOAT

locker accessed via a hatch located in the foredeck, just aft of the bow pulpit. This locker is large enough to store all of the anchor line. The bow pulpit includes a bow anchor roller where your anchor can stow while underway and can be used to lower and retrieve the anchor into/from the water.

Specifics regarding the proper techniques, equipment and conditions for safe anchoring can be found by referring to [Chapman Piloting: Seamanship & Boat Handling](#), or through a 'boating safety' course.

A helm switch labeled "Windlass" activates the foredeck anchor windlass to either raise or lower the anchor. This switch is only operable when the optional windlass is installed. Switches for the raising and lowering of the anchor line via the anchor windlass are located on the foredeck. To operate the windlass with the helm or the foredeck switches the windlass breaker on the D.C. System panel (located on the aft dinette bulkhead) must be ON. Please refer to the information provided by the windlass manufacturer in the owner's packet. For operating instructions, refer to the windlass manufacturer's owner's manual.

To secure the anchor into the bow roller while underway, a rope lanyard with an "S" hook on the end has been provided. To use, attach the hook to the anchor shackle and cinch the anchor tight into the bow roller. Wraps may be taken around the windlass to pull tight and then secure to the anchor cleat. The lanyard must be removed before anchoring. A cable, with a shackle on the free end, is attached to the foredeck for a secondary positive means to hold the anchor in the UP position. This must also be removed before anchoring.

## 5.4 AFTER RETURNING TO THE DOCK



### **WARNING**

**WHEN OPERATING AN ELECTRIC WINDLASS, BE CAREFUL TO KEEP HANDS AND FEET AWAY FROM THE WINDLASS DURING OPERATION. FAILURE TO DO SO CAN RESULT IN SERIOUS INJURY WHEN THEY ARE TRAPPED BETWEEN THE WINDLASS AND ROPE OR CHAIN.**

When you have returned to the dock, in order to maintain the finish and function of your boat, it is necessary to thoroughly wash it with a mild detergent soap and fresh water. After washing, in order to reduce spotting and maximize your boats appearance, dry all non-fiberglass surfaces with a dry towel or chamois.

When leaving your boat you should do the following:

1. Check the bilge areas for debris that might clog your bilge pumps while you are away.
2. Listen carefully and visually inspect for water leaks in the engine room forward and aft bilge areas, paying particular attention to the shaft logs and rudder posts.
3. Close all unnecessary seacocks.
4. Turn off all unnecessary electrical breakers.
5. Check to see that the auto bilge pump breakers are in the on position on the D.C. System Panel.

The bilge pumps and shower sump areas need to be checked, before leaving the boat, for debris that might clog the pumps. The float switches must also be checked to see that they are turning the pumps on and off properly. To check, just lift the float until the pump comes on, and lower until it stops. If they are not working, do not leave your boat unattended until they are fixed.

6. Check the security of all hatches and doors.
7. Check to see that all mooring lines are secure and that your boat is properly positioned in the slip so as to not interfere with the dock during tidal changes and storms.
8. Check to see that shore power cords and dockside water hoses have sufficient slack, if left attached. Dockside water supplies should be turned off.

When leaving the boat for any extended period, turn the Engine and House Battery Bank switches OFF. You should also leave the boat connected to shore power with the 120V A.C. battery chargers ON. This will maintain the battery voltage in the proper state, and allow for the operation of the automatic bilge pumps. Turn-

## OPERATING YOUR BOAT

ing OFF the Engine and House Battery Bank switches also disables power to the helm, preventing operation of the engines and other helm functions. If you are leaving the boat for a shorter period of time and wish to keep D.C. power supplied to other components, switching the ignition breakers on the D.C. System Panel to the OFF position will prevent the engines from being operated.

## Chapter 6

# COMMISSIONING YOUR BOAT

---

## 6.1 BEFORE LAUNCHING YOUR BOAT

To activate the warranty your Dealer is required to provide S2 Yachts with the Boat Registration and the Customer Acceptance Form with the signature of the original purchaser within 30 days.

The following items are best accomplished by your Tiara Yachts dealer, or another qualified marine service facility. Your engine and transmission should be prepared according to the information provided from the engine manufacturer.

Before launching your boat for the first time the following items should be done:

### 6.1.1 Bottom Paint

If your boat has come equipped with factory applied bottom paint, the second coat should be applied over the first, just before launching. The second coat is left off until this time so as to maximize the anti-fouling properties of the paint. Be sure that the bottom is clean and dry before applying the second coat. A gallon of paint has been provided by the factory for this purpose.

If your boat has not been ordered with factory applied bottom paint, and your boat will be kept in the water for an extended period of time (three weeks or more), we recommend you have the bottom painted. When painting the bottom, we recommend that the paint system you use not involve sanding or abrading the gelcoat surface in any way. Your Tiara comes with a five year warranty against blistering that may be voided by breaking the gelcoat surface. Whatever the system you choose, we recommend that you follow the paint manufacturer's recommendations for preparation and application, and that you consider having your Tiara Yachts dealer, or other qualified marine service facility, apply the paint. Remember, never sand the gelcoat surface, use a primer type of paint system.

### 6.1.2 Bilge Areas

Install the garboard drain plug, add new Teflon® tape to the drain plug threads everytime it is reinstalled, after removing the old tape. The drain plug is located under the aft floor hatch (see Figure 6-1). Be sure that it is installed tight. Close all seacocks.

## COMMISSIONING YOUR BOAT

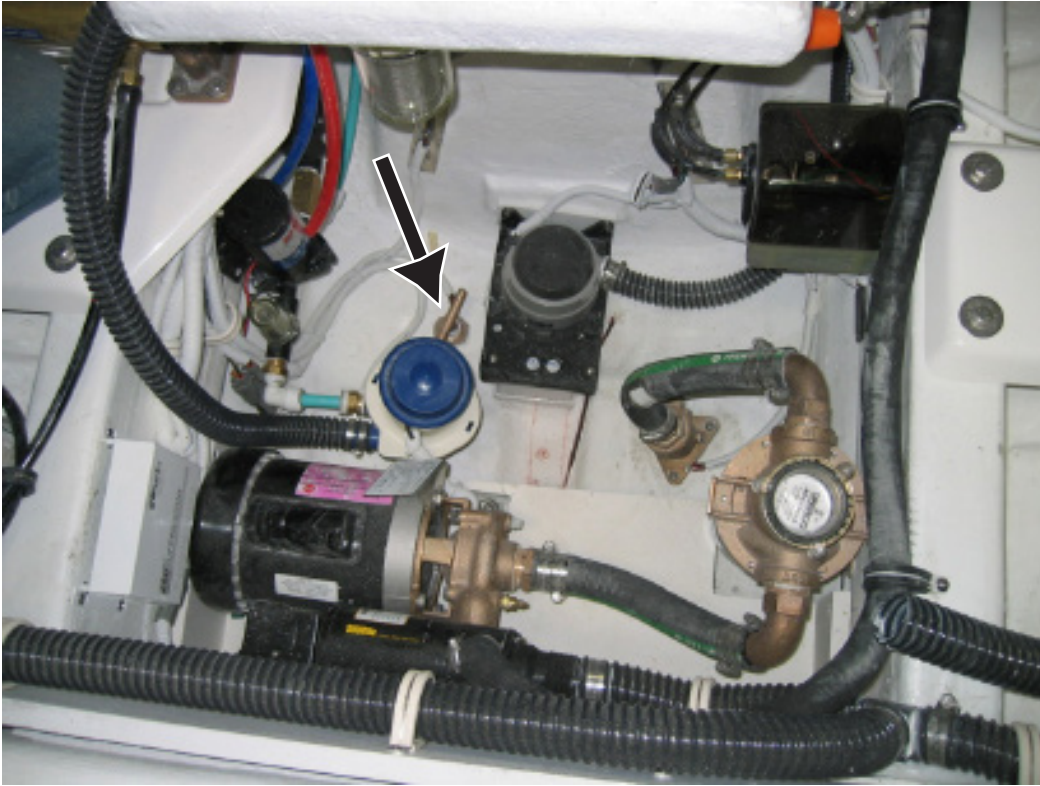

Figure 6-1: Garboard Drain Plug. See Arrow.

### 6.1.3 Electrical Systems

Check to see that the batteries are fully charged. If not, the batteries may be charged by hooking up the shore power cord (see Section 5.1.1) and running the 120V A.C. battery charger (see Chapter 4, Electrical Systems).

Check the electrolyte in each battery cell, making sure that they are filled to the specification recommended in section 4.2.2 in Chapter 4.

### 6.1.4 Installing the Propellers

To install the propellers (see Figure 6-2), the following procedure should be followed:

1. Remove adhesive tape, jam nuts and cotter pin from the prop end of the shaft.

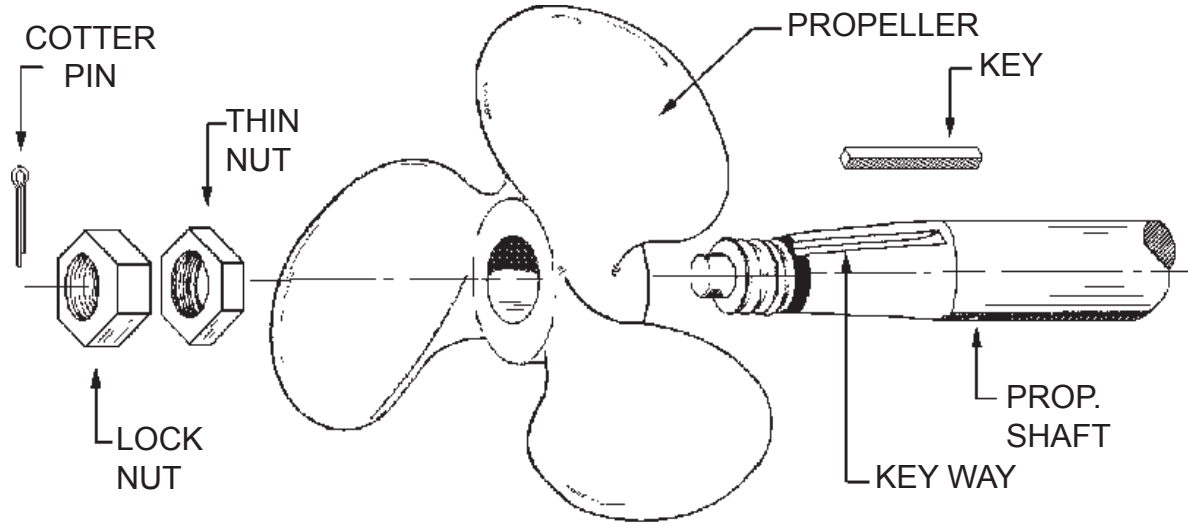

Figure 6-2: Propeller Instalation

2. Remove key by installing a 10-24 or 8-32 machine screw in the greased threaded hole in the key. Use the screw to pull the key out of the keyway.
3. Clean the shaft end, especially the tapered surfaces to remove all foreign material.



**CAUTION**

Do not install the propeller with a poorly fitted key in the keyway. A poorly fitting key may cause vibration underway, unexpected propeller shaft stress, and possible shaft failure.



**CAUTION**

Do not allow the key to slide forward in the shaft keyway and ride up on the radius at the forward end of the shaft keyway. Failure to prevent this may cause unacceptable shaft stresses and possible shaft and/or propeller failure.

## COMMISSIONING YOUR BOAT

4. Clean the internal taper of the propeller hub. Check for burrs or machining imperfections. Deburr and correct any imperfections.
  - A. If lapping propellers is part of your normal propeller installation procedure, perform this operation at this time.
5. With key removed, install propeller on shaft. By hand, push prop onto shaft until seated on taper. With a fine point magic marker such as a Sharpie®, mark the location of the forward end of the prop hub on the shaft.
6. Remove propeller.
7. Install key into shaft keyway. Key fit should be a light press fit. Use of a nylon or brass hammer may be needed. Gently tap key into the keyway until key is seated. Ensure key bottoms out in flat section of keyway away from spooned radius at end of keyway.
8. Reinstall propeller. Push prop on shaft until it seats on taper. Look at front of propeller hub. The front edge of the hub should be located at the mark on the shaft made in step 5.
9. If front edge of hub is at mark from step 5, go to step 13.
10. If front edge of hub is beyond (covering) mark, go to step 2 and repeat procedure.
11. If front edge of hub is not to the mark or behind the mark, double check steps 2, 3, 4, 5, 7, and 8 and repeat if necessary. If this is the second time you have tried these steps, go to step 12.
12. Determine cause of problem:
  - A. Make sure key is completely seated in flat section of keyway.
  - B. Make sure no debris or foreign material is between key, shaft keyway and propeller hub keyway.
  - C. Measure keyway height, shaft keyway depth, and prop hub keyway depth. The prop shaft keyway depth plus the prop hub keyway depth should be 0.010" to 0.015" greater than the keyway height. If it is not, report findings to your Tiara dealer for further assistance.



13. Install shortest brass prop jam nut and tighten to propeller. Care should be taken to ensure that torque is being applied to tighten prop shaft and not to bend shaft and deflect boat bottom. If torque applied causes the boat bottom to deflect or shaft to bend, the shaft may become slightly out of specified straight-line resulting in drivetrain vibration at some speeds.
14. Install second thicker brass jam nut. The same care should be taken as in step 13 when tightening this jam nut.
15. Finally, install the cotter pin in the hole provided at the end of the prop shaft. It is necessary to bend only one of the legs of the pin to secure it in place.

Repeat for the other propeller.

Be sure that the propellers are installed on the correct shaft. If they are on the wrong shaft, the boat will move in reverse when shifted into forward.

## 6.2 LIFTING YOUR BOAT

Now that your boat is ready to launch, it is necessary to lift it into the water with a marine hoist or travel lift. This should only be done by your TiaraYachts dealer or a qualified marine service facility and personnel.

Lifting your boat should only be done with slings located where indicated by sling tags on the hull side: port, starboard, forward and aft. The slings should be held at least the same beam as the boat with the hoist or spreader bars. Pads should be placed at the chine corners to ease the pressure while lifting.

## 6.3 AFTER LAUNCHING YOUR BOAT

The first thing to check is the bilge area and all thru-hulls, seacocks, rudder shaft logs, and propeller shaft logs to be sure they are not leaking. Open all seacocks



### CAUTION

Failure to follow the aforementioned lifting procedures while lifting your boat may result in structural damage to the hull and deck or underwater gear.

## COMMISSIONING YOUR BOAT

and make certain that the hoses and fittings are not leaking. Turn ON the bilge pumps and check that they are operational.

### 6.3.1 Fresh Water System

Prepare the fresh water system for operation. To prepare the system follow this procedure:

1. Open all faucets (hot & cold), set single lever action faucets to the warm position.

Note: If antifreeze was not used, skip to step 7.

2. Turn ON the fresh water pump breaker, located on the D.C. System Panel, located on the aft dinette bulkhead. The pump is self priming.
3. When anti freeze flow stops, turn the pump OFF. Do not close faucets at this time.
4. Fill fresh water tank with clean fresh water. The fill fitting for the water tank is on the starboard foredeck, forward of the waste tank fitting and it is labeled WATER. The tank should be filled until water runs out of the vent on the hull side, just below the fill.
5. Turn the pump ON and empty the water tank. When the water tank is empty turn the pump OFF.
6. Repeat steps 4 thru 5 until system is clean.
7. Final fill: Fill the fresh water tank (as indicated in step 4). Open the water heater valves on the water heater to the use position. The water heater is located on the starboard side of the engine room, outboard of the starboard engine (see Figures 6-3 & 6-4). Turn the fresh water pump ON (as indicated in step 2).
8. When a smooth flow of water is observed from all faucets, close faucets. The pump will shut off as the system pressure increases and any air should now be purged from the system.
9. The fresh water system is now commissioned.

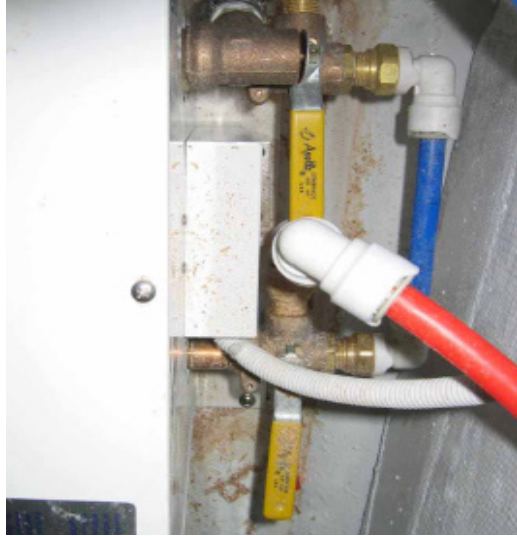

Figure 6-3: Water Heater Valves Closed.



Figure 6-4: Water Heater Valves Open.



### WARNING

INVESTIGATION OF PROBLEMS WITH ELECTRICAL SYSTEMS AND CIRCUITS ON YOUR BOAT SHOULD ONLY BE DONE BY QUALIFIED MARINE ELECTRICAL REPAIR PERSONNEL. FAILURE TO DO SO CAN RESULT IN EQUIPMENT DAMAGE, FIRES IN BOAT WIRING, SEVERE ELECTRICAL SHOCK AND DEATH.

### 6.3.2 Electrical Systems

Hook the shore power cord up to a source of dockside power and test all A.C. powered systems and circuits. Test all D.C. systems and circuits. Report all problems and questions to your Tiara Yachts dealer at once.

Check the generator fluids. Start your generator and test all A.C. systems connected to the generator. Follow any start-up procedures recommended by the generator manufacturer in their owner's manual.

### 6.3.3 Engines and Transmissions

The alignment between the transmission flange and propeller shaft flange must be checked before leaving the dock for the first time (see Figure 6-5). While this alignment is set before the boat leaves the factory, the boat may settle after shipment and then again when being put in the water. This must be checked and adjusted, if necessary, by your Tiara Yachts dealer or a qualified marine service facility. The boat must be in the water for at least 24 hours before checking the alignment.

The alignment should also be checked again at 25 hours, whenever the boat has been out of the water for an extended period, or at least once a year. If it is not within tolerances indicated in Figure 6-5, you must have it adjusted.

Check the engines and transmissions for proper oil and coolant fluid levels. Start the engines and check to see that they are operating properly. Check your engine manufacturer's owner's manual for any start-up and break-in procedures. See Section 5.1.5 for engine starting procedures.

### 6.3.4 Interior Equipment

Operate the head systems, per instructions provided by the head manufacturer, to be certain that the head system is operating properly.

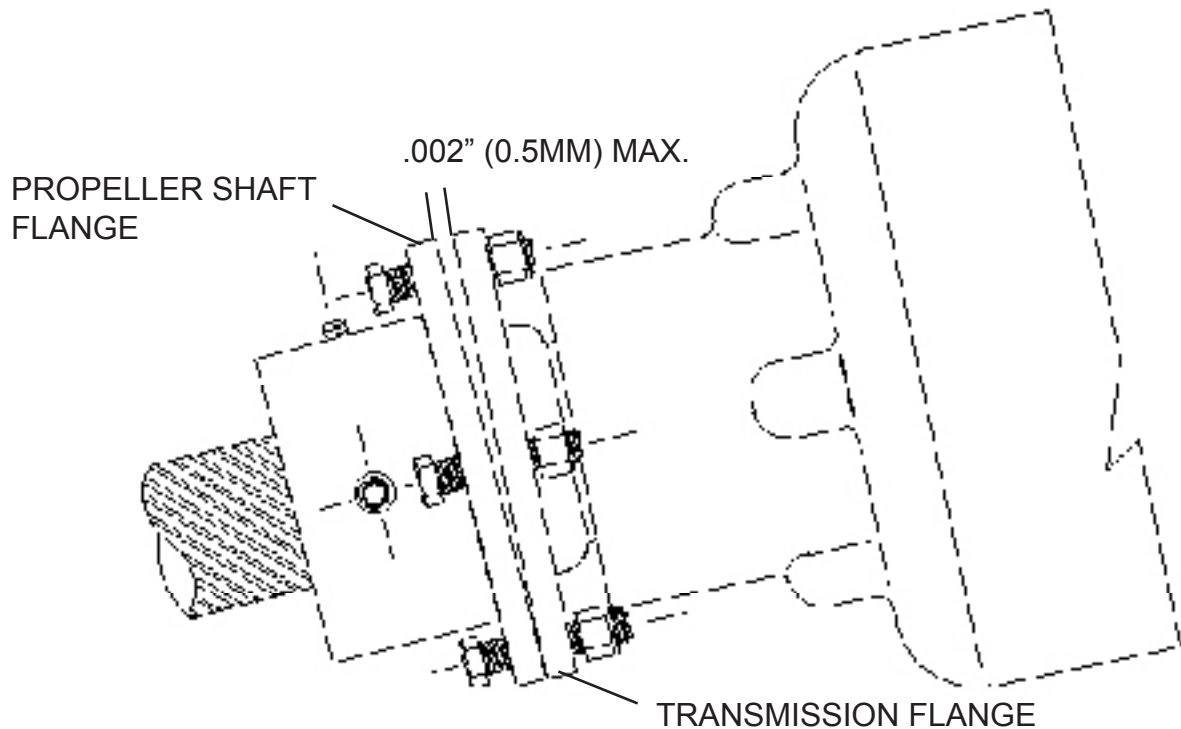

Figure 6-5: Transmission and Propeller Shaft Flange Alignment.

### 6.3.5 Exterior Equipment

Set up any canvas and vinyl enclosures to be certain that they fit properly. Clean the entire boat and wax all smooth surfaces (hull and deck). Hullsides are best done prior to launch.

At least once a year, apply a good grade automotive or marine wax to the smooth fiberglass surfaces. Boats with colored hulls will require more frequent maintenance and waxing and should be monitored more closely. It is strongly recommended that a colored hull be waxed at least twice a season. Follow the directions supplied with the wax.

After a period of time, when your boat has been exposed to the sunlight, the gel coat surface will fade, dull, or chalk. This will require buffing to bring back the original luster. When deciding to buff follow this guideline:

## COMMISSIONING YOUR BOAT

1. Confirm that there is noticeable chalking on the gel coat.
2. Use a medium grit buffing compound.
  - NOTE!: Buffing experience and use of an industrial grade buffer is strongly recommended.
3. Use a buffer with a clean pad.
4. Follow the buffing compound manufacturer's instructions.

After buffing, apply a coat of wax to all smooth surfaces; follow the instructions given by the manufacturer of the wax. The hull sides and transom should receive the same cleaning as the other fiberglass surfaces. Refer to an insert, in the front of the manual, for further elaboration on the care of fiberglass. If you encounter any problems notify your Tiara Yachts dealer at once, so that a resolution can be approached promptly. If the fiberglass or gelcoat surface should need repair, contact your Tiara Yachts dealer or another qualified marine service facility.



### CAUTION

Do not use abrasive cleaners on smooth fiberglass surfaces. They will dull the surface and allow dirt to penetrate the surface.

## Chapter 7

# ROUTINE MAINTENANCE

---

The various systems and products that make up your Tiara 39 will require routine maintenance from time to time, and many will require scheduled maintenance. For information about maintaining the items purchased by the factory and included in your boat, refer to the various products' owner's manuals, and Appendix C of this manual.

## 7.1 FUEL SYSTEM

The fuel system in your Tiara 39 has two composite fuel tanks; one aft and one forward. The aft fuel tank fuel fills are located port and starboard near the cockpit steps. The forward fuel tank fuel fills are located port and starboard forward on the deck. All fuel fills are labeled DIESEL. Vents are located below the fuel fills. These hoses need to be inspected seasonally to assure that the clamps that attach the hoses to the tanks, and fill and vent fittings, are tight, and that the hoses are in good condition.

The fuel filters/water separators are located on the forward engine room bulkhead (see Figure 7-1). The filter elements should be changed every 500 hours, every other oil change, annually or if a power loss is noticed, whichever comes first.

To change the filter elements, follow this procedure:

1. Turn OFF the fuel valves for each tank, see **Figures 7-2, 7-3 & 7-4**.
2. Remove the lid of the fuel filter element.
3. Remove the element by holding the molded handle and slowly pull upward with a twisting motion.



### **WARNING**

**FUEL IS EXTREMELY FLAMMABLE. ANY PROBLEMS WITH THE FUEL SYSTEM IN YOUR BOAT MUST BE CORRECTED IMMEDIATELY. FAILURE TO DO SO CAN RESULT IN SERIOUS INJURY OR DEATH.**

## ROUTINE MAINTENANCE



Figure 7-1: Engine room fuel filters/water separators.

4. Clean the canister and install a new filter element.
5. Replace the lid gasket with the new one that is supplied with the new element.



Figure 7-2: Aft fuel tank fuel valves, located below the aft centerline floor hatch.

6. Apply a coating of clean fuel to this seal prior to reassembly.
7. Fill the unit with clean fuel, then replace the lid.
8. Turn fuel valves ON.
9. Snugly tighten the T-handle BY HAND ONLY.



## ROUTINE MAINTENANCE



*Figure 7-3: In the lower, aft, inboard galley, is the garbage can drawer. To pull out the drawer to its maximum open position toggle one side of the slide locks UP (shown with index finger) and the opposite side DOWN.*



*Figure 7-4: Forward fuel tank valves.*

10. Start the engine and check for leaks. Additionally, after shutting the engine off check for leaks again.

11. Correct any leaks with the engine OFF.

**NOTE:** It is suggested that extra filter elements be carried in your vessel as one tankful of excessively contaminated fuel can require multiple element changes.

For the generator there is a separate fuel filter that services it alone. Located on the aft bulkhead between the fuel filter and the generator (see **Figure 7-5**). The generator fuel filter element should be changed every 400 hours or at every oil change.

To change the generator fuel filter element follow these instructions:

1. Turn OFF the fuel valves under the fuel inspection hatch in the aft cockpit. Refer to Figure 7-1.
2. Unscrew and remove the drain plug on the bottom of the generator fuel filter unit.
3. Remove the element with bowl connected from the Head/Mounting Bracket.
4. Remove the bowl and discard filter properly.
5. Clean the bowl and the bowl O-Ring gland.
6. Lubricate the O-Ring with clean motor oil and place it in the bowl gland.



### WARNING

**MAKE SURE ALL CONNECTIONS ARE TIGHT, AND THAT THERE ARE NO FUEL LEAKS.**

## ROUTINE MAINTENANCE

7. Spin the bowl onto the new element. CAUTION: Do not overtighten.
8. Lubricate element gasket with clean motor oil
9. Prime the fuel filter system: Fill Bowl/Element Assembly with clean fuel.
10. Spin Bowl/Element Assembly onto Head. Tighten by hand 1/2 to 3/4 turns after element gasket contacts head base.
11. Turn the fuel valves ON.
12. Start the generator and check for leaks.
13. Correct any leaks with the generator OFF.

## 7.2 FRESH WATER SYSTEM

The fresh water system requires very little maintenance. The biggest problem many boat owners have is that the water in the water tank (located under the floor, forward) is not used up and replenished often enough, and becomes stale. To combat this problem, you can drain the tank periodically and refill, or add a



*Figure 7-5: Generator fuel filter, located on the port aft engine room bulkhead.*

water conditioner to the tank periodically. Water conditioners are available at your Tiara Yachts dealer or R.V. supply stores.

The two main pieces of equipment in the fresh water system that may require maintenance are the water heater, and the fresh water pump. Refer to the owner's manuals supplied by the equipment manufacturers for specifics.

It may be necessary, on an annual basis, to clean the fresh water system strainer. The strainer is located near the pump under the forward centerline floor hatch in the interior (see **Figure 7-6**).

To clean the strainer follow these steps:

1. Switch the Fresh Water Pump breaker to OFF (D.C. System Panel).
2. Switch the Water Heater breaker to OFF (A.C. System Panel).
3. Depressurize the Fresh Water System by opening the galley faucet.
4. Locate the strainer sight glass (see **Figure 7-6**).
5. Have towels ready and placed under the sight glass.
6. Carefully unscrew the sight glass.
7. Remove the strainer screen.
8. Clean with mild soap and fresh water. Rinse with fresh water.
9. Replace the strainer screen and screw the sight glass back into place.
10. With faucets still open switch the Fresh Water breakers to ON.
11. After observing a steady flow of water through the faucet, close the faucet.
12. Switch the Water Heater breaker back to ON.

In the galley there is an in-line fresh water filter that services the galley water faucet. The in-line filter should be changed annually (see **Figure 7-7**).

## ROUTINE MAINTENANCE



*Figure 7-6: Fresh water filter and pump.*

## 7.3 ELECTRICAL SYSTEM

### 7.3.1 The 12V D.C. System

Your boat comes equipped standard with several **wet flooded cell batteries**. Twice a season, the batteries need to be cleaned. To do this:

1. Turn the Battery switches OFF ( on the D.C. System Panel and disconnect the battery(s).
2. Use a cloth and a solution of baking soda and water to wipe the tops.
3. Clean all battery terminals.
4. Reconnect all battery cables to the terminals and tighten.

Please refer to the owner's manual supplied by the battery manufacturer for any additional maintenance instructions.

The batteries in your boat are kept charged when the engines are running, by the engine's alternators. If equipment in the 12V D.C. system is used without the engines running, the batteries will lose their charge. The charge may be maintained with the 120V A.C. battery chargers while connected to shore power, or running the optional generator (see Chapter 4, Electrical Systems). If you have

## ROUTINE MAINTENANCE



*Figure 7-7: Access the galley inline freshwater filter by first removing the Corian® lid forward of the galley sink. Next remove the panel in the outboard storage compartment. The filter is on the aft side of the opening (arrow in lower picture).*

trouble getting them charged, or to hold a charge after charging, contact your Tiara Yachts dealer or a marine electrical service to investigate the cause.

Wet flooded cell batteries require periodic maintenance. In warmer climates, the electrolyte should be checked on a monthly basis. In cooler climates, the electrolyte can be monitored less frequently. The battery cells are covered with a round screw-in top. Unscrew each top to inspect each cell. Each cell of the group 31, wet flooded cell, deep cycle battery has a lead plate. If a maintenance inspection finds low electrolyte, in which the lead plate is visible, it is necessary to fill each low cell with **distilled water** so that the lead plate is no longer visible. The cells should not be topped off. If the cells are topped off its possible that during charging the electrolyte could boil over and cause damage to the battery or surrounding equipment, therefore, it is necessary to only fill the cells just over the lead plates, leaving an air space between the distilled water electrolyte and the cap. If upon inspection the lead plate is not visible, the cell is filled to specification.

## ROUTINE MAINTENANCE

Every time you use your boat, it is a good idea to check all the D.C. equipment on your boat. If you find something that does not work properly, contact your Tiara Yachts dealer or a qualified marine electrical service to repair.

### 7.3.2 The 120V/240V A.C. System

The terminals on each end of the shore cord should be checked for corrosion every time it is used, before using. The outside should also be checked for cracks and chafing of the insulation each time it is used.

The generator requires regular maintenance and you should refer to the owner's manual supplied by the generator manufacturer for specifics.

Every time you use your boat, it is a good idea to check all the A.C. equipment on your boat. If you find something that does not work properly, contact your Tiara Yachts dealer or a qualified marine electrical service to repair.

## 7.4 EXTERIOR EQUIPMENT AND FIBERGLASS

The rest of the exterior should be maintained after each use of the boat as follows:

1. Rinse the boat with clean fresh water.
2. Wash all exterior surfaces and hardware with a sponge, or soft bristle brush, and a solution of fresh water and mild detergent. Nonskid areas may be scrubbed with a stiff bristle brush.
3. Rinse the boat with fresh water.

At least once a year, apply a good grade automotive or marine wax to the smooth fiberglass surfaces. Boats with colored hulls will require more frequent maintenance and waxing and should be monitored more closely. It is strongly recommended that a colored hull be waxed at least twice a season. Follow the directions supplied with the wax.

**NOTE: The gel on the surface of the dash on the Tiara 39 is designed to minimize reflection. Waxing and or buffing will remove the anti-reflective properties of the gel surface on the dash. Do not wax or buff the gel surface on the dash. Clean with mild soap and fresh water.**

After a period of time, when your boat has been exposed to the sunlight, the gel coat surface will fade, dull, or chalk. This will require buffing to bring back the original luster. When deciding to buff follow this guideline:

1. Confirm that there is noticeable chalking on the gel coat.
2. Use a medium grit buffing compound.

**NOTE!:** Buffing experience and use of an industrial grade buffer is strongly recommended.

3. Use a buffer with a clean pad.
4. Follow the buffing compound manufacturer's instructions.

After buffing, apply a coat of wax to all smooth surfaces; follow the instructions given by the manufacturer of the wax. The hull sides and transom should receive the same cleaning as the other fiberglass surfaces. Refer to your boats literature packet for a pamphlet that further elaborates on the care of fiberglass.

If the fiberglass or gelcoat surface should need repair, contact your Tiara Yachts dealer or another qualified marine service facility.

### 7.4.1 Plexiglass

The hatches and portholes in your boat are made of plexiglass and must only be cleaned with mild soap and water, or plexiglass cleaner.

### 7.4.2 Hardware

All exterior chrome hardware may be cleaned with any available chrome cleaner. If the exterior stainless hardware begins to show signs of "bleeding", scrubbing with a mild, nonabrasive cleaner, such as Bon Ami®, will remove any tarnish. Follow with a coat of wax, as you would the fiberglass surfaces.

**NOTE:** Many parts of your boat, including the cleats and bow rail, have components of or are comprised of stainless steel. All metals in the marine environment,



## CAUTION

**Do not use abrasive cleaners on smooth fiberglass surfaces. They will dull the surface and allow dirt to penetrate the surface.**

## ROUTINE MAINTENANCE

including stainless steel, require proper maintenance to look the best and remain functional. To inhibit corrosive effects on stainless steel maintain it by: washing it with a mild soap and fresh water followed by a thorough rinsing with fresh water; dry with a chamois cloth. It is also recommended that stainless steel parts be waxed every two to three months. A nonabrasive polish such as premium auto wax works well. For areas that can not be waxed, a rust inhibitor spray is recommended to prevent corrosion.

### 7.4.3 Canvas and Upholstery

The upholstery on the exterior of your boat, such as the helm and companion seats, and cockpit coaming bolsters, should also be cleaned with a solution of mild detergent and water, or vinyl shampoo, and rinsed well with clean fresh water. An application of vinyl conditioner may also help restore them to their original condition.

The canvas and enclosures on your boat should be cleaned with a mild soap and clean fresh water. The underside should be brushed frequently, as this will help prevent the combination of dirt and moisture, from condensation, from staining the fabric. Wax the zippers occasionally to keep them working well. One of the best ways to keep upholstery fabrics looking good and to delay the need for deep or vigorous cleanings is to hose exterior fabrics off on a monthly basis with clean fresh water. For interior fabrics brushing off dirt before it becomes embedded in the fabrics, wiping up spills as soon as they occur, or spot cleaning soon after stains occur is best. Prevent dirt from becoming deeply embedded in the fabric and eliminate the need for more frequent vigorous cleanings. In most environments, a thorough cleaning will be needed every two to three years. For cleaning tactics consult the literature or website of the manufacturer of the upholstery installation that you are concerned with. All upholstery enclosures should be stowed in the bag supplied or hung neatly in a dry location. Do not allow upholstery to come in contact with dirt or wet environments for prolonged periods of time during storage or while in use.



## CAUTION

**Keep all strong solvents such as acetone, and strong window cleaners containing Ammonia (Windex®), away from plexiglass surfaces. They can cloud and cause crazing in the plexiglass surface.**



#### 7.4.4 Hull Bottom

The portion of the hull that is below the water line should be kept clean and free of marine growth with the use of an antifouling paint. Refer to the paint manufacturer for recommended periodic cleaning procedures. Typically, the bottom will need to be repainted once a year and then cleaned a few times during the year. Contact your local Tiara Yachts dealer for recommended local cleaning procedures and services. Failure to keep the bottom clean will result in loss of boat performance and fuel economy.

#### 7.4.5 Underwater Gear

The underwater gear (shafts, struts, propellers, rudders etc.) do not come painted with the antifouling paint, if that option is purchased. Consequently, regular scrubbing is required, depending on where your boat is stored, in order to keep them clean. Fouled underwater gear can greatly effect your boat's performance, especially growth on the propeller.

Sacrificial zincs have been installed on the propeller shafts, trim tabs, and on the transom of your boat, to prevent electrolysis of underwater hardware. The zincs should be replaced when they become depleted by 50% or more. Regular inspection is recommended to monitor their condition. See your Tiara dealer or local qualified marine service facility for replacement.

**NOTE:** Bottom paint must not be applied to the zincs.

Annually, the strut cutlass bearings should be checked for wear. If the bearings are worn, they will cause excessive shaft vibration while running, and therefore should be replaced. To replace, see your Tiara dealer or other qualified marine service facility.

#### 7.4.6 Optional Washdowns

It is important to keep the "o" ring on the insert end of the washdown hoses lubricated. To lubricate the washdown quick disconnects apply a liquid mild soap such as a liquid boat wash to the insert on the hose end. For a long term lubrication solution apply petroleum jelly such as Vaseline®. Depending on the location and usage, a monthly application may be necessary. Apply a light coat to the hose connection and insert it into the washdown port.

### 7.5 INTERIOR EQUIPMENT AND DECOR

The interior of your boat should be maintained much like the inside of your home. The fabrics that the cushions are made of should be treated much like the fabrics

## ROUTINE MAINTENANCE

in home upholstery. The major difference is that the interior may be subjected to moisture not found at home. Periodically, put the cushions, blankets, sheets, etc. out in the sun to allow them to dry thoroughly and air out well. If they get wet with salt water, due to a hatch or porthole being left open, be sure to rinse them with fresh water to remove the salt crystals and then dry thoroughly. Salt crystals retain moisture and will damage the material.

The carpet should be vacuumed periodically and cleaned just the same as a home carpet.

The teak bulkheads were coated with polyurethane varnish before leaving the factory and should only need dusting periodically with furniture polish.

The Corian® surfaces should be cleaned with a mild soap and water, or a non-abrasive cleaner, such as Bon Ami®, for difficult stains.

Plexiglass surfaces should be cleaned as in Section 7.4.2.

## 7.6 ENGINE ROOM

The engine room should be kept clean and free of any debris. A clean engine room assures that the engines and generator will receive a clean supply of air while running, and any problems or leaks will be immediately obvious during routine engine fluid checks.

### 7.6.1 Engines, Transmissions and Generator

As mentioned in Section 5.1, it is important to check your engine, transmission, and generator fluids every time you use the boat, and daily on long trips. If the engines and transmissions are kept clean, leaks and other problems are easier to spot. Oil, coolant, and filter change intervals are outlined in the engine and generator manufacturer's owner's manual. Please read them and follow their recommendations exactly. Have all engine, transmission, and generator maintenance performed by your Tiara dealer or other qualified marine service facility.

Your main engine exhaust system is comprised of an exhaust riser at the engine turbo charger outlet, hoses connecting the riser to a horizontal lift style muffler under the cockpit sole, and hoses connecting the muffler to the hull side outlet near the transom. The only maintenance these components should require is to periodically check the hose clamps for proper tightness.

## 7.6.2 Oil Change System

As a convenience during regular maintenance intervals, an oil change system for the main engines, transmissions, and generator, is installed in the aft starboard engine room (see **Figure 3-4 in Chapter 3**). Please read the instructions provided from the system manufacturer for operation.

**Note:** Be certain to clean up any oil spilled in the bilge during oil changing operations. Failure to do so can allow the bilge pumps to transfer the oil into the surrounding water. Properly dispose of any oil contaminated rags per the local environmental requirements.

## 7.6.3 Stuffing Boxes

Your Tiara 39 comes equipped with PSS (packless sealing system) propeller shaft seals for stuffing boxes (see **Figure 7-8**). These shaft seals use engine raw cooling water for lubricant and have a hose running from the shaft seal to the engine. The system should not leak water into your boat. If you notice leakage of



### WARNING

**A WIDE VARIETY OF COMPONENTS USED ON THIS VESSEL CONTAIN OR EMIT CHEMICALS KNOWN TO THE STATE OF CALIFORNIA TO CAUSE CANCER AND BIRTH DEFECTS AND OTHER REPRODUCTIVE HARM.**

**EXAMPLES INCLUDE:**

- Engine and generator exhaust.
- Engine and generator fuel, and other liquids such as coolants, oil, and especially used motor oil.
- Cooking fuels.
- Cleaners, paints, and substances used for vessel repair.
- Waste materials that result from wear of vessel components.
- Lead from battery terminals and from other sources such as ballast or fishing sinkers.

## ROUTINE MAINTENANCE

the seal during or after a trip, contact your local Tiara Yachts dealer or qualified marine service facility. Additional information from the shaft seal manufacturer is provided in the owner's packet.

### 7.6.4 Ventilation System

The engine room ventilation system is comprised of large hull side air inlets, port and starboard.

The engine room intake plenums are designed to remove moisture from the incoming air and drain it overboard. The plenum drains are molded into the plenum, there are no fittings or hoses to maintain.

### 7.6.5 Raw Water Intake Strainers

The engine raw water intakes, generator raw water intake, air conditioning raw water intake, and raw water washdown pump intake are equipped with strainers. The strainers should be checked each time you use the boat to assure that no debris has accumulated that may block the flow. If they are clogged and need cleaning, follow this procedure:

1. With the related equipment not operating, close the seacock, at the hull bottom, to stop the flow of water.
2. Remove the top of the filter by unscrewing counterclockwise. A spanner wrench has been provided for this purpose.
3. Lift the strainer out by the handle on the top.
4. Remove any debris from the strainer screen and rinse with clean water. Check to be sure that the O-ring under the top is intact and replace if necessary.
5. Install the strainer, replace the cover, and tighten with the spanner wrench.
6. Open the seacock, start the related equipment, and check the system for leaks.

## 7.7 RAW WATER SEACOCKS

The raw water seacocks should be closed and opened at least monthly to ensure that they do not become seized. Debris and ma-



**CAUTION**

The Federal Water Pollution Control Act prohibits the discharge of oil or oily waste into or upon the navigable waters of the United States or the waters of the Contiguous Zone if such discharge causes a film or sheen upon or a discoloration of the surface of the water or causes a sludge or emulsion beneath the surface of the water. Violators are subject to substantial civil and/or criminal sanctions including fines and imprisonment.



**CAUTION**

Always return the oil change system valves to the closed position after using the system. Failure to do so can result in transfer of oil between engines and/or generator due to crankcase pressures.



**CAUTION**

Always use the correct amount and type of engine oil recommended by the equipment manufacturer. Failure to do so can result in premature equipment failure, and loss of equipment warranty.

rine growth can accumulate and hinder the proper operation of the sea cocks. If they are difficult to operate contact your Tiara Yachts dealer and have them serviced. There are raw water seacocks for the engines (2), air conditioner, generator, live well (option), and raw water wash downs.

**7.8 HEAD SYSTEM**

The head in your Tiara 39 comes supplied with operating and maintenance instructions from the manufacturer. Schematics of the head system are shown in Appendix E.

## ROUTINE MAINTENANCE

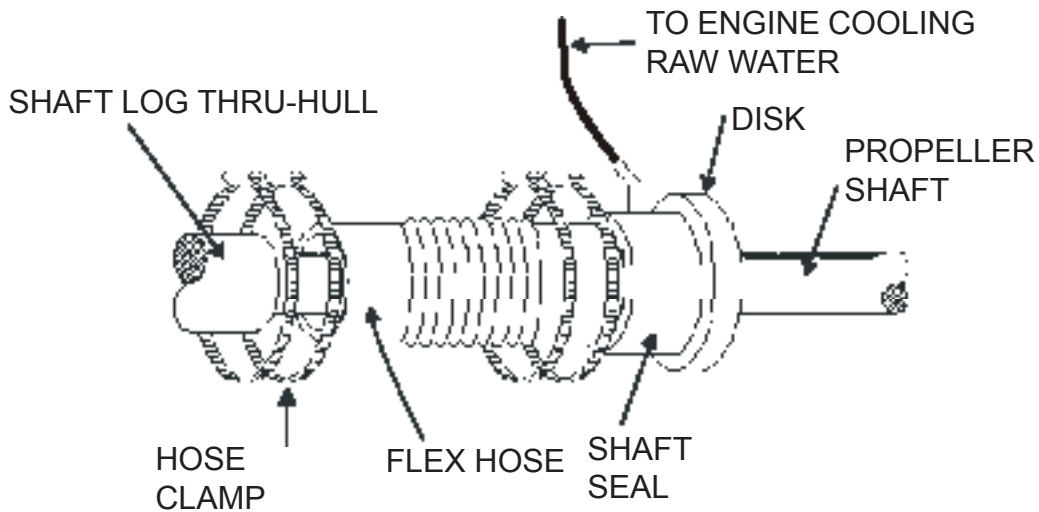

Figure 7-8: PSS Shaft Log Seal

When the holding tank (located in the port side engine room) is full, it is necessary to pump it out, see **Figure 7-9**.

The pump out procedure is as follows:

1. Set a course to a marine facility where a pump out station is located.
2. Remove the cap from the **waste** deck fitting, located on the port side deck, with a spanner wrench. Turn counterclockwise until loose and remove.
3. Insert the pump out hose into the opening.
4. Remove all waste from the holding tank.
5. Fill the tank with clean water and pump out again.
6. Replace the cap and tighten.

**Note:** The optional Overboard Discharge Seacock is wired to the closed position at the factory.

To pump waste overboard follow this procedure.

1. Open the Overboard Discharge Seacock, located in the aft starboard engine room, by pulling the handle to the vertical position.

2. Turn ON the Waste Pumpout breaker on the D.C. System Panel.
3. When finished reverse the entire procedure

## **7.9 DRAINAGE SYSTEM**

The drainage system consists of the forward, mid, and aft bilge pumps, the shower sump, and many other drains.

The bilge pumps and shower sump areas need to be checked, before leaving the boat, for debris that might clog the pump. The float switches must also be checked to see that they are turning the pumps on and off properly. To check, just lift the float until the pump comes on, and lower until it stops. If the bilge pumps are not working, do not leave your boat unattended until they are fixed.

The other hoses should only need to be checked every other month to be sure that they are draining properly. If clogged, pressurized water should be sufficient to clear.

Forward below the berth there is a grey water macerator drain manifold that collects drainage from the head, galley, and air conditioning condensation. Periodically this manifold should be inspected and cleared of any clogging debris. Access it through the forward berth hatch. The clear cover on the manifold box unscrews for maintenance access.

## **7.10 AIR CONDITIONER FILTERS**

The air conditioning units have a thin rubber mesh filter on the air intake side (see **Figures 7-10 & 7-11**). The filter(s) should be removed and cleaned periodically. Carefully remove the filter by sliding it upwards taking care not to bend the aluminum grill behind the filter, clean, and replace. There are optional units inside the starboard seat box in the upper cockpit.

## ROUTINE MAINTENANCE



*Figure 7-9: The Dometic® Tank Monitor Panel is located in the upper hullside cabinet above the dinette. Lights indicate the status of the waste tank and fresh water tank quantities. The graphic guide on the left of the panel indicates full or empty. A full head indicates a full waste tank and it should be promptly pumped out.*



### **CAUTION**

**It is illegal to discharge raw sewage from a vessel within a three mile limit of the territorial waters of the United States of America. It is illegal to discharge raw sewage from a vessel within the navigable waters and rivers of the United States including the Great Lakes. When in international waters it is the responsibility of the vessel owner/operator to follow local laws and restrictions.**





Figure 7-10: The A/C unit below the aft inboard dinette seat. The arrow points to the mesh filter.



Figure 7-11: The A/C unit below the master stateroom aft berth storage. The arrow points to the mesh filter.

**ROUTINE MAINTENANCE**

**This page intentionally left blank.**

## Chapter 8

# STORING AND WINTERIZING YOUR BOAT

---

If you live in a climate where you will not be able to use the boat for several months a year, there are a number of things that must be done to prevent damage to your boat from the cold and from lack of usage. These items assume that your boat will be hauled out of the water during this storage time. To lift the boat, follow the instructions in Section 5.2.

### 8.0.1 Supporting the Boat During Storage

The best way to support your boat when it is out of the water is on a cradle, made specifically for this purpose. The cradle must be well supported and placed on a level surface. It must be placed in the proper fore and aft position in order to properly support the hull. When the cradle is in the correct location, the bunks will uniformly touch the bottom of the hull. Custom made cradles are available from the factory, through any Tiara Yachts dealership. The cradles come with padding on the bunks to protect the bottom of the boat.

### 8.0.2 Storage

If the boat is to be stored indoors, be sure that the building has enough ventilation. It is important that the boat be well ventilated during storage.

If the boat is to be stored outdoors, a proper cover is necessary to protect the boat from the elements. Construct a frame over the top of the boat to support a canvas or plastic cover. The frame should be built so as to be slightly wider than the outside of the boat. The cover should be fastened securely, as a loose cover can flap and damage the gelcoat surface.

## 8.1 FUEL SYSTEM

The fuel tanks should be filled to near capacity before storage in order to minimize fuel deterioration. The addition of an appropriate fuel conditioner will also prolong the fuel life. Fuel remaining in the fuel systems of the engines and generator should be treated per the engine or generator manufacturer's recommendations.

## 8.2 FRESH WATER SYSTEM

To prepare your boat's fresh water system for winterizing, the system must be drained. The procedure for draining is:

1. Make sure the water heater breaker on the A.C. System Panel is in the OFF position. The A.C. System Panel is located on the aft dinette bulkhead.

## STORING & WINTERIZING

2. Open all fresh water faucets. Leave the faucets open.
3. Turn ON the fresh water pump to drain the water tank, the switch is on the D.C. System Panel.
4. Turn OFF the fresh water pump.
5. Remove the hoses from the input and output sides of the water pump, and let the tank and hoses drain into the bilge.
6. Turn ON the fresh water pump for a few seconds to remove the water from the bottom of the pump and then turn OFF the fresh water pump. The switch is on the D.C. System Panel.



### **WARNING**

**HOT WATER WILL CAUSE BURNS. DO NOT FOLLOW THESE PROCEDURES WITH HOT WATER IN THE SYSTEM.**



### **CAUTION**

**Do not operate the water heater without water in the fresh water system.**

7. Drain the water from the water heater by opening the valve on the bottom of the water heater and letting the water drain into the bilge. Close the valve when the water tank is empty.

The system must then be flushed with potable water antifreeze. To flush the system:

1. Close all fresh water system faucets.
2. Reconnect the hoses to the water & pump.

3. Pour five gallons of potable water systems antifreeze into the water tank via the deck fill.
4. Turn water heater valves to bypass position. See Figure 6-3 in Chapter 6.
5. Turn ON the fresh water pump breakers on the D.C. System Panel.
6. Open all faucets in the system, hot and cold, one at a time, until the pink antifreeze begins to come out, and then close. Leave the very last faucet visited open until air blows out of the faucet, making sure that the pink antifreeze is present first, and then close it.
7. Turn OFF the fresh water pump.

To protect the shower sump from freezing:

1. Pour two quarts of potable water antifreeze into the shower drain.
2. Run the shower sump until the antifreeze is gone. The switch is on the D.C. System Panel.
3. Turn OFF the shower sump pump switch.

## 8.3 ELECTRICAL SYSTEM

### 8.3.1 12V D.C. System

The only major component of your D.C. system that needs preparation for winter storage are the batteries. To prepare the batteries for storage:

1. Make sure the batteries are fully charged.
2. Turn the House and Engine Battery Bank switches to the OFF position on the D.C. System Panel.
3. Disconnect the batteries.
4. Clean the battery terminals and case. Apply a coat of petroleum jelly to the terminals, or spray liberally with Boeshield T9.

## STORING & WINTERIZING

5. Make sure that all battery electrolyte cells are filled to specification. See section 7.3.1 for filling specifications.
6. Leave the batteries disconnected during the storage period. If left connected they could discharge over time causing damage to the batteries. Optimally the batteries should be charged periodically during storage if left connected. Please refer to the owner's manual supplied by the battery manufacturer for any additional winterizing instructions.

You should check the information provided with any installed electronics to see if they may be damaged by the lowest temperatures that your boat may experience. If so, remove and store in a clean, dry area that will protect them from damaging temperatures.

### 8.3.2 120V A.C. System

The installed A.C. electrical system in your Tiara 39 does not require any winterizing procedure, with the exception of the generator. For generator winterization, see Section 8.6.1.

## 8.4 EXTERIOR EQUIPMENT AND FIBERGLASS

The entire exterior of your boat should be completely washed and dried before storage for the winter. The fiberglass surfaces, bottom paint, zincs, etc. should wait for the spring for maintenance and/or replacement.

Underwater gear can be coated with a light coat of petroleum jelly or boat wax to prevent corrosion. The cutlass bearing in each strut should be coated with a rubber lubricant to prevent seizing. Do not use petroleum products on the rubber bearing.

All exterior hardware should be protected by a heavy coat of boat wax or petroleum jelly.

## 8.5 INTERIOR EQUIPMENT

The interior should be carefully cleaned before storage. All carpeting should be vacuumed, all upholstery cleaned, and the interiors of all cabinets should be emptied and wiped clean. All bilge areas should also be wiped clean. Whether stored inside or outside, open all interior drawers, lockers, and cabinets to allow them to properly ventilate and stay fresh. If possible, remove all upholstery, carpeting, and cushions and store them elsewhere.

### 8.5.1 Air Conditioning

Your Tiara 39 has two standard self-contained air conditioning units, one located below the berth, one below the companionway steps. Optionally there are two additional units below the port side lounge in the upper cockpit. The raw water pump and intake strainer are located on centerline aft below the transom floor hatch. The raw water seacock is also located in this area.

To winterize the air conditioning units:

1. After hauling the boat, open the raw water seacock, unscrew the drain from the strainer site glass (see **Figure 8-1**), disconnect the raw water pump intake. Remove all water from the hoses, seacock and strainer.
2. Disconnect the outlet hose from the raw water pump and drain all water from the air conditioning units.
3. Run the pump for a few seconds (D.C. System Panel) to be sure there is no water left in it. Reconnect the hoses to the pump, screw the drain back into the strainer.
4. The system can be filled with an antifreeze mixture. Refer to the air conditioning manufacturer's owner's manual for the recommended procedure.

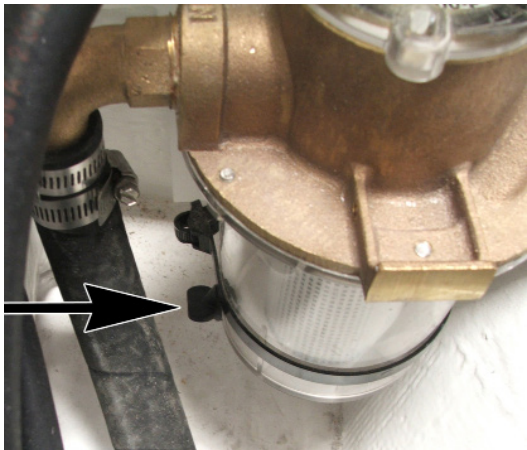

*Figure 8-1: Raw water strainer site glass drain plug.*

### 8.5.2 Head System

To winterize the head system follow these steps:

1. Drain the fresh water system.
2. Run the toilet without incoming water (this will drain the waste tank outlet hose).
3. Take your boat to a facility with the required pump-out facilities and follow the procedure outlined in Section 7.8 in Chapter 7.

## STORING & WINTERIZING

4. If desired, flush 1-2 gallons of potable antifreeze into the system. Please refer to the waste system drawing in Appendix E.

## 8.6 ENGINE ROOM AND BILGE AREAS

All the bilge areas, forward under the floor, engine room, and aft under the cockpit, should be wiped clean. The hoses leading from the bilge pumps forward, in the engine room and under the cockpit floor, should be disconnected from the pumps and drained. Any bilge water should then be removed with a sponge and wiped dry.

### 8.6.1 Engines, Transmissions and Generator

The engines, transmissions, and generator should be prepared for storage according to the manufacturer's recommendations. Please refer to the owner's manuals for these items for specific instructions.

### 8.6.2 Exhaust Systems

The exhaust systems for the engines and generator must have the water drained from their mufflers.

The main engine mufflers should be drained by removing the plug from the aft end of the muffler (see **Figure 8-2**), allow the water to drain out, and replace the plug.

Follow a similar procedure for the generator muffler (see **Figure 8-3**).

### 8.6.3 Raw Water Systems



## CAUTION

**When reconnecting raw water hoses, be certain to tighten clamps well. Leaking fitting on raw water hoses can sink the boat.**

The engine raw water cooling systems must be drained. Open the raw water seacock(s) and remove and clean the strainer(s) for each engine, disconnect the hoses, if necessary, to remove all water. Reconnect all hoses and reassemble the strainer when complete. Consult the engine manufacturer's literature for more information.

The raw water washdown system must also be drained.

To do so:



## STORING & WINTERIZING

1. Open the seacock and the washdown faucet, in the cockpit, inside the starboard gunnel storage.
2. Disconnect the hoses from the intake and outlet sides of the pump and let the water drain out. Use compressed air, if necessary, to remove all the water. The raw water pump is located under the aft transom floor hatch, see **Figure 8-4**.
3. Run the pump for a few seconds to remove all water from the pump body.

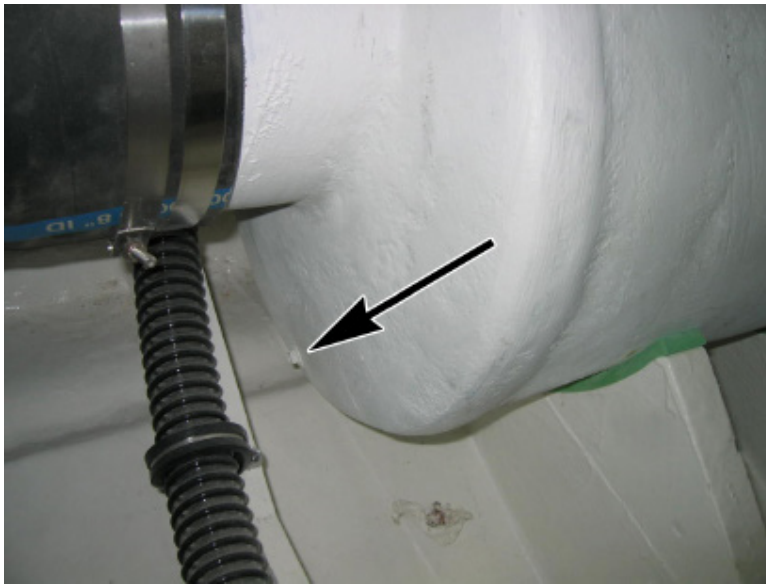

*Figure 8-2: Port engine muffler plug shown. The muffler plugs are accessed through the port and starboard floor hatches.*



### **WARNING**

**BE CERTAIN THAT THE EXHAUST DRAIN PLUGS ARE INSTALLED TIGHTLY. FAILURE TO DO SO WILL ALLOW ENGINE EXHAUST GASES CONTAINING CARBON MONOXIDE AND WATER INTO THE BILGE AREA.**



## CAUTION

Prior to transporting your vessel by truck and trailer the engine mufflers must be drained to prevent sea water reversion into the engines.

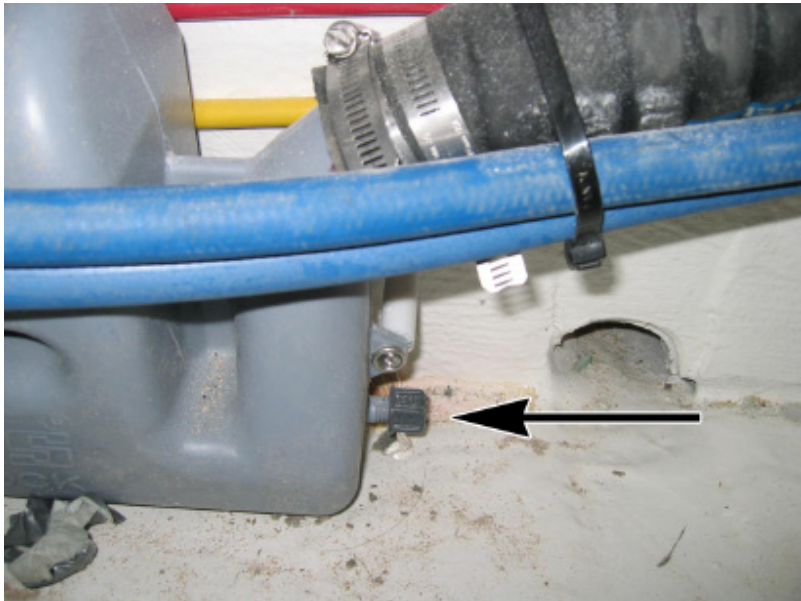

*Figure 8-3: Generator muffler plug shown. The generator muffler is located below the port side of the generator.*

4. Lubricate the pump impeller per instructions in the pump owner's manual.
5. Reconnect all hoses and tighten the clamps securely.

### 8.6.4 Steering System

The steering system is located in the bilge, underneath the center cockpit hatch.

To prepare it for storage:

1. Use clean water and detergent to wash off the steering arms and linkage. Dry with a clean cloth.

## STORING & WINTERIZING

2. Apply a light coat of petroleum jelly to the piston rod.
3. Lubricate the pivot points and upper rudder bearings with a light-weight oil.
4. Inspect the packing glands for wear. If worn, replace with new packing.

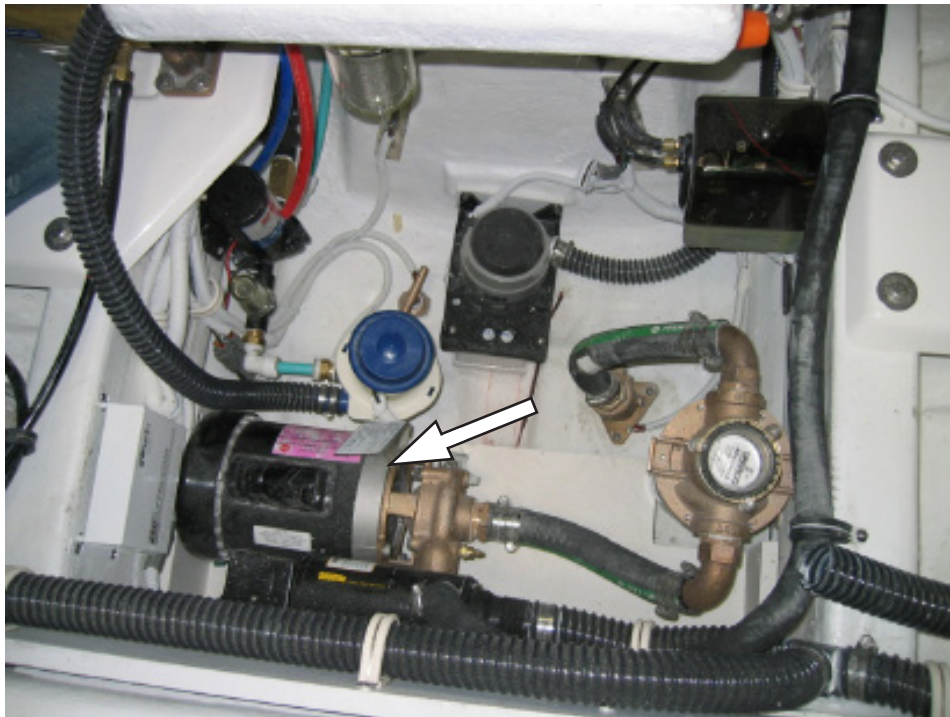

*Figure 8-4: Raw water pump, shown with arrow.*

5. Coat all components with a light coat of petroleum jelly or other suitable corrosion inhibiting material such as BOESHIELD T-9® or WD-40®.

## STORING & WINTERIZING



### **CAUTION**

**Be very careful with compressed air. Too much pressure or volume can damage the raw water system.**



### **CAUTION**

**When reconnecting raw water hoses be certain to tighten clamps well. Leaking fittings on raw water hoses can sink the boat.**

## Appendix A

# SPECIFICATIONS

---

### A.1. GENERAL

#### ENGINE OPTIONS

Twin Cummins® 6.7L.....	480 H.P.
Twin Cummins® QSC .....	550 H.P.

#### GENERAL SPECIFICATIONS

L.O.A. without Standard Swim Platform.....	39'3"	11.96 meters
L.O.A. with Standard Swim Platform.....	41'11"	12.77 meters
Beam.....	15'0"	4.57 meters
Draft (with Props) ... ..	3'6"	1.06 meters
Height from Waterline to Top of Windshield.....	9'7"	2.92 meters
Height from Waterline to Top of Optional Hardtop... ..	10'4"	3.15 meters
Approximate Dry Weight .....	24,500 lbs.	11,113 kg
Standard Fuel Capacity .....	535 U.S. gallons	2,025 liters
Water Capacity.....	120 U.S. gallons	454 liters
Holding Tank Capacity .....	38 U.S. gallons	144 liters
Sleeping Accommodations.....	5	
Deadrise at Transom.....	18°	

#### COCKPIT SIZE

Upper .....	95 sq. ft.	8.83 sq. meters
Lower .....	80 sq. ft.	7.43 sq. meters

APPENDIX A

**A.2. BOAT SPECIFIC**

Boat Serial No: **SSUCC026E516**

Material Description .....	Serial No
A/C, HELM RA VLD16K .....	51698966
A/C, HELM RA VLD16K .....	51698967
A/C, INTERIOR SYSTEM 16K RA.....	51598113
A/C, INTERIOR SYSTEM 6K RA.....	51497407
BOW THRUSTER 185TT 6KW/8HP #591805 12V .....	591805
CHARGER, BATTERY CENTAUR 12/60 60AMP .....	HQ1447KLI5W
DOOR,COMPANIONWAY W/SCREEN RA .....	912, 943
ENGINE KEY, PORT.....	961
ENGINE KEY, STARBOARD.....	961
ENGINE, QSB6.7 ZF85A 2.50:1 160 PORT.....	73823601
ENGINE, QSB6.7 ZF85A 2.50:1 160 STBD.....	73747755
FRIDGE/FREEZE,2-DRAWER DW180IXD4-ES-1 .....	14490212
GARMIN 8215 DISPLAY.....	3BC002752
GARMIN 8215 DISPLAY.....	474000029
GARMIN GHC20.....	33R008991
GENERATOR,9KW MDKBL E-QD W/SHIELD .....	B150795352
GRILL,KENYON ELECTRIC SS WO/LID #B70060.....	683960
STOVE, ELECTRIC 2-BURNER #B41601 .....	684756
TRANSMISSION SER NO - PORT ENG .....	20238764
TRANSMISSION SER NO - STAR ENG .....	20238763
WATER HEATER,11GAL 120V #F1100WTY W/EXCH .....	866663

**Aft:** In, near, or toward the stern of a boat.

**Aground:** A boat stuck on the bottom.

**Amidships:** In or toward the part of a boat midway between the bow and stern.

**Anchor:** A specially shaped heavy metal device designed to dig efficiently into the bottom under a body of water and hold a boat in place.

**Anchor locker:** a locker, usually located in the bow of a boat, used for stowing the anchor line or chain

**Anchorage:** An area specifically designated by governmental authorities in which boats may anchor.

**Ashore:** On shore.

**Astern:** Behind the boat, to move backwards.

**Athwartship:** At right angles to the center line of the boat.

**Barnacles:** Small, hard-shelled marine animals which are found in salt water attached to pilings, docks and bottoms of boats.

**Beam:** The breadth of a boat usually measured at its widest part.

**Beamy:** boats of greater than normal beam

**Bearing:** The direction of an object from the boat, either relative to the boat's direction or to compass degrees.

**Berth:** A bunk or a bed on a boat.

**Bilge:** The bottom of the boat below the flooring.

**Bilge Pump:** A pump that removes water that collects in the bilge.

**Boarding:** Entering or climbing into a boat.

**Boarding Ladder:** Set of steps temporarily fitted over the side of a boat to assist persons coming aboard.

**Boat Hook:** Short shaft of wood or metal with a hook fitting at one end shaped to aid in extending one's reach from the side of the boat.

**Bow:** The front end of a boat's hull.

**Bow Line:** A line that leads forward from the bow of the boat.

**Bow Rail:** Knee high rails of solid tubing to aid in preventing people from falling overboard.

**Bridge:** The area from which a boat is steered and controlled.

**Bridge Deck:** A deck forward and usually above the cockpit deck.

**Broach:** When the boat is sideways to the seas and in danger of capsizing; a very dangerous situation that should be avoided.

**Bulkhead:** Vertical partition or wall separating compartments of a boat.

**Cabin:** Enclosed superstructure above the main deck level.

**Capsize:** When a boat lays on its side or turns over.

**Chapman's:** Chapman Piloting & Seamanship, by Chapman and Jonathon Eaton; published by Hearst.

**Chain locker:** See anchor locker.

**Chock:** A deck fitting, usually of metal, with inward curving arms through which mooring or anchor lines are passed so as to lead them in the proper direction both onboard and off the boat.

**Cleat:** A deck fitting, usually of metal with projecting arms used for securing anchor and mooring lines.

**Closed Cooling System:** A separate supply of fresh water that is used to cool the engine and circulates only within the engine.

**Coaming:** A vertical piece around the edges of cockpit, hatches, etc., to stop water on deck from running below.

**Cockpit:** An open space, usually in the aft deck, outside of the cabin.

**Companionway:** Opening in the deck of a boat to provide access below.

**Compartment:** The interior of a boat divided off by bulkheads.

**Cradle:** A framework designed to support a boat as she is hauled out or stored.

**Cutlass Bearing:** A rubber bearing in the strut that supports the propeller shaft.

**Deck:** The floor-like platform of a boat that covers the hull.

**Displacement:** The volume of water displaced by the hull. The displacement weight is the weight of this volume of water.

**Draft:** The depth of water a boat needs to float.

**Drydock:** A dock that can be pumped dry during boat construction or repair.

**Dry Rot:** A fungus attack on wood areas.

**Electrical Ground:** A connection between an electrical connector and the earth.

**Engine Beds:** Sturdy structural members running fore and aft on which the inboard engines are mounted.

**EPIRB:** Emergency Position Indicating Radio Beacon. Operates as a part of a world-wide satellite distress system.

**Even Keel:** When a boat floats properly as designed.

**Fathom:** A measure of depth. One Fathom = 6 feet.

**Fender:** A soft object of rubber or plastic used to protect the topsides from scarring and rubbing against a dock or another vessel.

**Fend off:** To push or hold the boat off from the dock or another boat.

**Flying Bridge:** A control station above the level of the deck or cabin.

**Flukes:** The broad portions of an anchor which dig into the ground.

**Following Sea:** A sea that comes up from the stern and runs in the same direction that the boat is going.

**Fore:** Applies to the forward portions of a boat near the bow.

**Foundering:** When a boat fills with water and sinks.

**Fuel pump:** feeds fuel under pressure

**Freeboard:** The height from the waterline to the lowest part of the deck.

**Galley:** The kitchen of a boat.

**Grab Rail:** Hand-hold fittings mounted on cabin tops or sides for personal safety when moving around the boat, both on deck and below.

**Ground Tackle:** A general term including anchors, lines, and other gear used in anchoring.



**Grounds:** A boat touches the bottom.

**Gunwale:** The upper edge of a boat's side.

**Hand Rail:** Rail mounted on the boat, for grabbing with your hand, to steady you while walking about the boat.

**Harbor:** An anchorage which provides reasonably good protection for a boat, with shelter from wind and sea.

**Hatch:** An opening in the deck with a door or lid to allow for access down into a compartment of a boat.

**Head:** A toilet on a boat.

**Heat Exchanger:** Used to transfer the heat that is picked up by the closed cooling system to the raw cooling water.

**Helm:** The steering and control area of a boat.

**Hull:** The part of the boat from the deck down.

**Inboard:** A boat with the engine mounted within the hull of the boat. Also refers to the center of the boat away from the sides.

**Inboard/outboard:** Also stern drive or I/O. A boat with an inboard engine attached to an outboard drive unit.

**Keel:** A plate or timber plate running lengthwise along the center of the bottom of a boat.

**Knot:** Unit of speed indicating nautical miles per hour. 1 knot = 1 nautical mile per hour (1.15 miles per hour). A nautical mile is equal to one minute of latitude: 6076 feet. Knots times 1.15 equals miles per hour. Miles per hour times .87 equals knots.

**Lay-up:** To decommission a boat for the winter (usually in northern climates).

**Leeward:** The direction toward which the wind is blowing.

**Length On The Waterline (LWL):** A length measurement of a boat at the waterline from the stern to where the hull breaks the water near the bow.

**Length Overall (LOA):** a length measurement of a boat from the fore part of the stem to the after part of the stern

**Life Preserver:** provides additional buoyancy to keep a person afloat when he/she is in the water

**Limber Hole:** A passage cut into the lower edges of floors and frames next to the keel to allow bilge water to flow to the lowest point of the hull where it can be pumped overboard.

**Line:** The term used to describe a rope when it is on a boat.

**Lists:** A boat that inclines to port or starboard while afloat.

**Locker:** A closet, chest or box aboard a boat.

**Loran:** An electronic navigational instrument which monitors the boat's position using signals emitted from pairs of transmitting stations.

**Lunch hook:** A small light weight anchor typically used instead of the working anchor. Normally used in calm waters with the boat attended.

**Marina:** A protected facility primarily for recreational small craft.

**Marine Ways or Railways:** Inclined planes at the water's edge onto which boats are hauled.

**Midships:** The center of the boat.

**Moored:** A boat secured with cables, lines or anchors.

**Mooring:** An anchor permanently embedded in the bottom of a harbor that is used to secure a boat.

**Nautical Mile:** A unit of measure equal to one minute of latitude. (6076 feet)

**Nun Buoy:** A red or red-striped buoy of conical shape.

**Oil Pump:** Supplies lubricating oil where needed within the engine.

**Outboard:** A boat designed for an engine to be mounted on the transom. Also a term that refers to objects away from the center line or beyond the hull sides of a boat.

**Overhead:** the ceiling of a cabin or compartment,

**Pad Eye:** A deck fitting consisting of a metal eye permanently secured to the boat.

**Personal Flotation Device (PFD):** For example, a life preserver or throwable device.

**Pier:** A structure which projects out from the shoreline.

**Pile or Piling:** A long column driven into the bottom to which a boat can be tied.

**Pitch:** The measure of the angle of a propeller blade. Refers to the theoretical distance the boat travels with each revolution of the propeller.

**Pitching:** The fore and aft rocking motion of a boat as the bow rises and falls.

**Plenum:** a chamber for directing air flow, as in engine intake air plenum

**Port:** The left side of the boat when facing the bow.

**Porthole (port):** The opening in the side of a boat to allow the admittance of light and air.

**Propeller:** A device having two or more blades that is attached to the engine and used for propelling a boat.

**Propeller Shaft:** Shaft which runs from the back of the engine gear box, aft, through the stuffing box, shaft log, struts, and onto which the propeller is attached.

**Pyrotechnic Distress Signals:** Distress signals that resemble the brilliant display of flares or fireworks.

**Raw Water Cooled:** Refers to an engine cooling system that draws sea water in through a hull fitting or engine drive unit, circulates the water in the engine, and then discharges it overboard.

**Reduction Gear:** Often combined with the reverse gear so that the propeller turns at a slower rate than the engine.

**Reverse Gear:** Changes the direction of rotation of the propeller to provide thrust in the opposite direction for stopping the boat or giving it sternway.

**Roll:** A boat's sideways rotational motion in rough water.

**Rope Locker:** See anchor locker.

**Rubrail:** Railing (often rubber or hard plastic) that runs along the boat's sheer to protect the hull when coming alongside docks, piers, or other boats.

**Rudder:** A movable flat surface that is attached vertically at or near the stern for steering.

**Sea anchor:** An anchor that does not touch the bottom. Provides drag to hold the bow in the most favorable position in heavy seas.

**Scupper:** An opening in the hull side or transom of the boat through which water on deck or in the cockpit is drained overboard.

**Seacock:** Safety valves installed just inside the thru-hull fittings and ahead of the piping or hose running from the fittings.

**Shaft Log:** Pipe through which the propeller shaft passes.

**Sheer:** The uppermost edge of the hull.

**Sling:** A strap which will hold the boat securely while being lifted, lowered, or carried.

**Slip:** A boat's berth between two pilings or piers.

**Sole:** The deck of a cockpit or interior cabin.

**Spring Line:** A line that leads from the bow aft or from the stern forward to prevent the boat from moving ahead or astern.

**Starboard:** The right side of a boat when facing the bow.

**Steerageway:** Sufficient speed to keep the boat responding to the rudder or drive unit.

**Stem:** The vertical portion of the hull at the bow.

**Stern:** The rear end of a boat.

**Stern line:** a line that leads aft from the stern of the boat

**Stow:** To pack away neatly.

**Stringer:** Longitudinal members fastened inside the hull for additional structural strength.

**Strut:** Mounted to the hull which supports the propeller shaft in place.

**Strut Bearing:** See "cutlass bearing."

**Stuffing Box:** Prevents water from entering at the point where the propeller shaft passes through the shaft log.

**Superstructure:** Something built above the main deck level.

**Swamps:** When a boat fills with water from over the side.

**Swimming Ladder:** Much the same as the boarding ladder except that it extends down into the water.

**Taffrail:** Rail around the rear of the cockpit.

**Thru-hull:** A fitting used to pass fluids (usually water) through the hull surface, either above or below the waterline.

**Topsides:** The side skin of a boat between the waterline or chine and deck.

**Transom:** A flat stern at right angles to the keel.

**Travel Lift:** A machine used at boat yards to hoist boats out of and back into the water.

**Trim:** Refers to the boat's angle or the way it is balanced.

**Trough:** The area of water between the crests of waves and parallel to them.

**Twin-Screw Craft:** A boat with two propellers on two separate shafts.

**Underway:** When a boat moves through the water.

**Wake:** Disrupted water that a boat leaves astern as a result of its motion.

**Wash:** The flow of water that results from the action of the propeller or propellers.

**Waterline:** The plane of a boat where the surface of the water touches the hull when it is afloat on even keel.

**Water pump:** circulates cooling water

**Watertight Bulkhead:** Bulkheads secured so tightly so as not to let water pass.

**Wharf:** A structure generally parallel to the shore.

**Windlass:** A winch used to raise and lower the anchor.

**Windward:** Toward the direction from which the wind is coming.

**Working Anchor:** An anchor carried on a boat for most normal uses. Refers to the anchor used in typical anchoring situations.

**Yacht Basin:** A protected facility primarily for recreational small craft.

**Yaw:** Side-to-side movement, usually caused by rough seas.

## Owner's Guide: Care & Upkeep of Fiberglass Products

As the world's premier gel coat supplier, Polynt Composites has provided this brochure as a guide to properly maintain and care for your gel coat surface.

Gel Coats provide a protective layer against weathering on a surface. Over time, exposure to sunlight, water, dust and chemicals cause wear and tear on the gel coat surface. This results in chalking, discoloration, yellowing or loss of gloss. By following simple, regular maintenance procedures, you can minimize these effects.

### Basic Maintenance

When not in use, keep the gel coat surface out of the sun or covered with a canvas tarp. Do not use plastic sheeting or other non-porous materials as they trap moisture between the cover and the surface, causing damage to the gel coat.

For best results, use a cleaner recommended for use with fiberglass and follow label instructions. Alternatively, you can wash the surface with a mild detergent, such as dishwashing soap.

DO NOT use automatic dishwasher detergent, abrasive cleaners, bleach, strong acids or bases (i.e. TSP or ammonia). Only use pH neutral cleaners.

Wax at least twice a year to restore gloss and protect the finish. Only use a wax that is recommended for gel coat surfaces and follow instructions carefully. NEVER wax a gel coat surface in direct sunlight.

### Corrective Procedures\*

#### Chalking

A fine rubbing compound as well as a mild detergent will reduce the weathering and chalking accumulated on the surface. Use only a fine grit compound and follow label directions carefully. DO NOT apply rubbing compound in direct sunlight. For best results, wax after applying compound. When applying wax, remove excess compound and apply a thin layer of wax using a clean cloth. It is recommended to use a wax designed for fiberglass.

#### Scratches, Nicks and Stains

Most scratches and nicks can be removed by using a rubbing compound followed by waxing as described above. Deep marks or gouges should be professionally repaired.

Most stains can be removed by washing with mild detergent. For stubborn stains, use a fine abrasive household cleanser designed for fiberglass products, followed by waxing to restore its original luster.

Non-water soluble stains such as grease and oil, rubber heel marks, etc., can be removed by using a solvent such as acetone, rubbing alcohol, toluene or xylene, followed by a mild detergent. If these solvents are not effective, try a rubbing compound or fine sanding followed by a rubbing compound and then waxing.

If you have questions, consult your local dealer.



**Polynt Composites USA**  
99 E. Cottage Ave  
Carpentersville, IL 60110

800-322-8103

*\*Always try a test spot first*



Maintenance	Each Use	Weekly	Monthly	Semi Annually	Yearly	As Needed
Clean hull below the waterline				X		
Bottom paint					X	X
Check sacrificial anodes			X			
Replace sacrificial anodes					X	
Wash boat canvas & hardware	X		X			
Wax exterior gelcoat				X		X
Clean & protect hardware						X
Polish & protect plastic glass					X	X
Clean exterior upholstery	X					X
Clean cabin & interior upholstery						X
Flush engine with fresh water	X					
Spray metal components in bilge with a protector			X			
Clean bilge				X		X
Check bilge for leaks	X		X			
Inspect & operate thru-hull valves			X			
Inspect steering & control systems	X					
Service steering & control systems				X		
Inspect fuel system for leaks	X					
Inspect & service fuel system				X		
Inspect fuel tank vents & screens					X	
Replace fuel filters					X	
Lubricate fuel fill o-rings			X			
Inspect fire extinguisher			X			
Test bilge pump auto switches	X					
Inspect & protect electrical components, wire & battery connections				X		
Check battery electrolyte & service			X			
Test and inspect AC electrical system & shore power cord				X		
Inspect water systems for leaks				X		
Check neutral safety switch	X					
Check trim tab fluid level			X			









DEPARTMENT OF HOMELAND SECURITY U.S. Coast Guard <b>RECREATIONAL BOATING ACCIDENT REPORT</b>		OMB Control Number: 1625-0003 Expires: 07/31/2022						
<p><b>INSTRUCTIONS:</b> Use "Report required because" section below to determine if a report is required for your accident. If required, please have each vessel owner or operator involved in the accident submit a report to their state reporting authority. Each boat operator/owner involved in an accident should submit a separate report. For each question below, please provide answers if applicable and if known; otherwise leave blank.</p> <p style="text-align: center;"><b>Privacy Act Notice</b></p> <p><b>Authority:</b> 46 U.S.C. 6102 and 33 CFR 173 &amp; 174 authorize the collection of information on boating accidents.  <b>Purpose:</b> The Coast Guard uses this information for statistical purposes, chiefly to inform the public, to measure the Program's efforts, and to regulate issues relating to boating safety.  <b>Routine Uses:</b> The Coast Guard shares this information within the agency, and if state and federal law permit it, to the public.</p>								
<b>REPORT SUBMISSION</b>								
<p><b>Report required because (select all that apply):</b></p> <p><input type="checkbox"/> At least one person in this accident <i>died</i>. If so, how many? _____</p> <p><input type="checkbox"/> At least one injured person in this accident <i>required or was in need of treatment beyond first aid</i>. If so, how many? _____</p> <p><input type="checkbox"/> At least one person in this accident <i>disappeared</i> and has not yet been recovered. If so, how many? _____</p> <p><input type="checkbox"/> All boat and other property damage (e.g., fishing/hunting gear) caused by this accident <i>totaled (or likely totaled) \$2,000 or more</i>:</p> <p style="padding-left: 40px;">Approximate value of damage to <i>your</i> boat: \$ _____</p> <p style="padding-left: 40px;">Approximate value of damage to <i>your</i> other property: \$ _____</p> <p><input type="checkbox"/> Your or another <i>boat</i> in this accident was (or likely was) a <i>total loss</i></p> <p><b>Report submitted by (select all that apply):</b></p> <p><input type="checkbox"/> Boat Operator (required if possible)</p> <p><input type="checkbox"/> Boat Owner (if operator unable, or same as operator)</p> <p><input type="checkbox"/> Other (describe): _____</p>		<p><b>To be submitted within:</b></p> <p>48 hours (if injury, disappearance or death)                  10 days (if boat/property damage only)</p> <p>To be submitted to: (Local State Reporting Authority)</p> <p>Phone: _____</p> <p><small>You may submit any comments concerning the accuracy of the burden estimate or any suggestions for reducing the burden to: Commandant (CG-BSX-21), U.S. Coast Guard, Washington, DC 20593-0001 or Office of Management and Budget, Paperwork Reduction Project (1625-0003), Washington, DC 20503. Questions relating to the collection of this data should be sent to the Coast Guard.</small></p>						
		<b>For State Agency Use Only</b>						
		<table border="1" style="width:100%; border-collapse: collapse;"> <tr> <td style="width: 50%;">First Name</td> <td style="width: 50%;">Last Name</td> </tr> <tr> <td colspan="2">Phone: _____</td> </tr> <tr> <td colspan="2">Primary Cause of Accident</td> </tr> </table>	First Name	Last Name	Phone: _____		Primary Cause of Accident	
First Name	Last Name							
Phone: _____								
Primary Cause of Accident								
First Name	Last Name	Phone						
<b>ACCIDENT SUMMARY</b>								
<p><b>WHEN</b></p> <p>Date: (mm/dd/yyyy)      Time: am <input type="checkbox"/> pm <input type="checkbox"/> (select one)</p> <p><b>WHERE</b></p> <p>Body of Water Name</p> <p>Location (on water) description</p> <p>Nearest city/town</p> <p>County: _____ State: _____</p>		<p><b>ACCIDENT DESCRIPTION:</b> Briefly describe this accident (attach extra pages if necessary)</p>						
<p><b>YOUR BOAT – PEOPLE</b></p> <p># people on board (including operator): _____</p> <p># people being towed (e.g., on tubes, skis): _____</p> <p># people wearing lifejackets (on board or towed): _____</p> <p><b>OTHER BOATS INVOLVED IN ACCIDENT</b></p> <p># of other boats involved: _____</p>								
		<p><b>DAMAGE TO YOUR BOAT:</b> Briefly summarize any damage to your boat</p>						
		<p><b>DAMAGE TO YOUR OTHER PROPERTY: (NOT BOAT)</b>                  Briefly summarize any damage to your other property (not boat)</p>						

For each question below, please provide answers IF APPLICABLE AND IF KNOWN, otherwise leave blank.														
<b>YOUR BOAT</b>														
<b>BOAT IDENTIFICATION</b>														
Your Boat Name:						Manufacturer:								
Model Name:						Model Year:								
Registration #:						Documentation #:								
Hull Identification # (HIN):						Rented: <input type="checkbox"/> Yes <input type="checkbox"/> No								
<b>SIZE ESTIMATES</b>														
Length: ft.		Depth from transom (stern) to keel (bottommost point): ft.				in.		Beam width at widest point: ft.						
<b>HULL MATERIAL</b>														
Type of Hull Material (select one)														
Fiberglass			Wood			Rubber/vinyl/canvas			Other (describe):					
Aluminum			Steel			Plastic								
<b>BOAT TYPE</b>														
Boat Type (select one)						Available Propulsion (select all that apply)								
Cabin motorboat		Inflatable boat		Personal watercraft (PWC) (e.g., Wave Runner™, Jet Ski™, Sea-Doo™)		Paddlecraft:		Propeller		Air thrust				
Open motorboat		Houseboat				Canoe		Sail		Other (describe):				
Auxiliary sail		Sail (only)		Air boat		Kayak		Manual						
Pontoon boat		Rowboat		Other (describe):		Standup Paddleboard		Water jet						
<b>ENGINE</b>														
# Engines:			Engine type and horsepower (select one)						Fuel type (select all that apply)					
Manufacturer			Outboard		Sterndrive		Inboard		Pod drive		Gas		Electric	
Total horsepower: hp			No engine		Other:				Diesel		Other:			
<b>SAFETY MEASURES</b>														
Organizations that have conducted a vessel safety check (VSC) on board your boat within the past year (including carriage of safety equipment, e.g., lifejackets, anchor and line, fire extinguishers):														
US Coast Guard Auxiliary: VSC Decal? <input type="checkbox"/> Yes <input type="checkbox"/> No				Federal Agency (Name):										
US Power Squadrons: VSC Decal? <input type="checkbox"/> Yes <input type="checkbox"/> No				State Agency (Name):										
				Other Agency (Name):										
# Life jackets on board:		# Fire extinguishers on board:		Type of fire extinguishers (e.g., ABC):										
		# Fire extinguishers used:												
<b>ACCIDENT DETAILS – EXTERNAL CONDITIONS</b>														
<b>WEATHER</b>														
Overall weather was (select one)				It was (select one)		Visibility was (select one)			Wind was (select one)					
Clear		Raining		Day		Good			0 mph (none)					
Cloudy		Snowing		Night		Fair			Over 0, up to 12 mph (light)					
Foggy		Hazy				Poor			Over 12, up to 25 mph (moderate)					
Other (describe):				Approximate air temperature:		°F			Over 25, up to 55 mph (strong)					
									Over 55 mph (stormy)					
<b>WATER</b>														
Overall water conditions (select one):						Other water conditions:								
Up to 6 in. waves (calm)						Approximate water temperature:			°F					
Over 6 in., up to 2 ft. waves (choppy)						Strong current?			Yes		No			
Over 2 ft., up to 6 ft. waves (rough)						Hazardous waters? (e.g., rapid tidal flow, currents)			Yes		No			
Over 6 ft. waves (very rough)						Congested waters?			Yes		No			

For each question below, please provide answers IF APPLICABLE AND IF KNOWN, otherwise leave blank.			
<b>ACCIDENT DETAILS – ACTIVITIES AND OPERATIONS ON YOUR BOAT</b>			
<b>OPERATOR/PASSENGER ACTIVITIES</b>			
Operator/passenger activities on <i>your</i> boat at time of accident:			
Activities were (select one)		Operator/Passenger activities (select all that apply)	
<input type="checkbox"/> Recreational	<input type="checkbox"/> Fishing	<input type="checkbox"/> Tubing	<input type="checkbox"/> Starting engine
<input type="checkbox"/> Commercial	<input type="checkbox"/> Hunting	<input type="checkbox"/> Water Skiing	<input type="checkbox"/> Making repairs
	<input type="checkbox"/> White water activity (e.g., rafting)	<input type="checkbox"/> Relaxing	<input type="checkbox"/> Other (list):
<b>BOAT OPERATIONS</b>			
Your boat operations at time of accident (select all that apply)			
<input type="checkbox"/> Cruising (underway under power)	<input type="checkbox"/> Drifting	<input type="checkbox"/> Racing	<input type="checkbox"/> Towing another vessel
<input type="checkbox"/> Changing direction	<input type="checkbox"/> At anchor	<input type="checkbox"/> Rowing/paddling	<input type="checkbox"/> Launching
<input type="checkbox"/> Changing speed	<input type="checkbox"/> Being towed	<input type="checkbox"/> Docking/undocking	<input type="checkbox"/> Tied to dock/mooring
<input type="checkbox"/> Sailing	<input type="checkbox"/> Other (list):		
<b>ACCIDENT DETAILS – CONTRIBUTING FACTORS ON YOUR BOAT</b>			
<b>CONTRIBUTING FACTORS</b>			
Indicate factors on <i>your</i> boat which may have contributed to this accident (select all that apply)			
<input type="checkbox"/> Alcohol use	<input type="checkbox"/> Improper lookout	<input type="checkbox"/> Dam/lock	<input type="checkbox"/> Starting in gear
<input type="checkbox"/> Drug use	<input type="checkbox"/> Operator inattention	<input type="checkbox"/> Force of wake/wave	<input type="checkbox"/> Sharp turn
<input type="checkbox"/> Excessive speed	<input type="checkbox"/> Operator inexperience	<input type="checkbox"/> Hazardous waters	<input type="checkbox"/> Restricted vision (e.g., fog)
<input type="checkbox"/> Improper anchoring	<input type="checkbox"/> Language barrier	<input type="checkbox"/> Heavy weather	<input type="checkbox"/> Mission/inadequate aids to navigation (e.g., buoy, daymarker)
<input type="checkbox"/> Improper loading	<input type="checkbox"/> Navigation rules violation	<input type="checkbox"/> Ignition of fuel or vapor	<input type="checkbox"/> Inadequate on-board navigation lights
<input type="checkbox"/> Overloading	<input type="checkbox"/> Failure to vent	<input type="checkbox"/> Hull failure	<input type="checkbox"/> People on gunwale, bow or transom
<input type="checkbox"/> Other (describe):			
<b>ACCIDENT DETAILS – YOUR BOAT</b>			
<b>MACHINERY/EQUIPMENT FAILURE</b>			
Failure of the following machinery/equipment on <i>your</i> boat contributed to this accident (select all that apply)			
<input type="checkbox"/> Engine	<input type="checkbox"/> Onboard lights	<input type="checkbox"/> Shift	<input type="checkbox"/> Sound equipment (e.g., horn, whistle)
<input type="checkbox"/> Electrical system	<input type="checkbox"/> Seats	<input type="checkbox"/> Radio	<input type="checkbox"/> Auxiliary equipment
<input type="checkbox"/> Fuel system	<input type="checkbox"/> Steering	<input type="checkbox"/> Fire extinguisher	<input type="checkbox"/> Other (list):
<input type="checkbox"/> Sail/mast	<input type="checkbox"/> Throttle	<input type="checkbox"/> Ventilation	
<input type="checkbox"/> Onboard navigation aids (e.g., GPS)			
<b>ACCIDENT DETAILS – EVENTS ON YOUR BOAT</b>			
<b>ACCIDENT EVENTS</b>			
Types of events occurring to/on <i>your</i> boat during accident (select all that apply)			
<input type="checkbox"/> Collision with recreational boat	<input type="checkbox"/> Flooding/swamping	<input type="checkbox"/> Person fell overboard	
<input type="checkbox"/> Collision with commercial boat (e.g., tug, barge)	<input type="checkbox"/> Fire/explosion – fuel	<input type="checkbox"/> Person fell on/within boat	
<input type="checkbox"/> Collision with fixed object (e.g., dock, bridge)	<input type="checkbox"/> Fire/explosion – non-fuel	<input type="checkbox"/> Sudden medical condition	
<input type="checkbox"/> Collision with submerged object (e.g., stump, cable)	<input type="checkbox"/> Carbon monoxide exposure	<input type="checkbox"/> Person struck by boat	
<input type="checkbox"/> Collision with floating object (e.g., log, buoy)	<input type="checkbox"/> Mishap of skier, tuber, wake boarder, etc.	<input type="checkbox"/> Person struck by propeller or propulsion unit	
<input type="checkbox"/> Capsizing	<input type="checkbox"/> Person left boat voluntarily	<input type="checkbox"/> Person electrocuted	
<input type="checkbox"/> Grounding	<input type="checkbox"/> Person ejected from boat (caused by collision or maneuver)		
<input type="checkbox"/> Sinking	<input type="checkbox"/> Other (describe):		

For each question below, please provide answers IF APPLICABLE AND IF KNOWN, otherwise leave blank.									
<b>ACCIDENT DETAILS – YOUR BOAT- INJURED PEOPLE RECEIVING OR IN NEED OF TREATMENT BEYOND FIRST AID</b>									
<i>Report only injured people on, struck by, or being towed by your boat, receiving or in need of treatment beyond first aid. Do not report injured people on, struck by, or being towed by another boat or no boat (e.g., swimmers, people on a dock). If more than one injured person to report, attach additional copies of this page. If none, SKIP INJURED PEOPLE section.</i>									
<b>INJURED PERSON</b>									
First Name			MI		Last Name				
Street									
City			State			Zip			
Phone			Date of Birth (mm/dd/yyyy)			Age			
<b>INJURY DETAILS</b>									
<b>Injury caused when person (select all that apply)</b>					<b>Nature of most serious injury (select one)</b>				
Struck the (e.g., boat, water):					Scrape/bruise		Dislocation		
Was struck by a (e.g., boat, propeller):					Cut		Internal organ injury		
Was exposed to carbon monoxide poisoning					Sprain/strain		Amputation		
Received an electric shock					Concussion/brain injury		Burn		
Other (describe):					Spinal cord injury		Other (describe):		
Person was wearing lifejacket?			Yes	No	Broken/fractured bone				
Person received treatment beyond first aid?			Yes	No	Body part of most serious injury (e.g., head, trunk, leg):				
Person was admitted to a hospital?			Yes	No					
<b>ACCIDENT DETAILS – YOUR BOAT – DEATHS/DISAPPEARANCES</b>									
<i>Only report deaths/disappearances of people on, struck by, or being towed by your boat. If more than one death/disappearance to report, attach additional copies of this page. If none, SKIP DEATHS/DISAPPEARANCES section.</i>									
<b>PERSON WHO DIED/DISAPPEARED</b>									
First Name			MI		Last Name				
Street									
City			State			Zip			
Phone			Date of Birth (mm/dd/yyyy)			Age			
<b>DETAILS OF DEATH/DISAPPEARANCE</b>									
<b>Injury caused when person (select all that apply)</b>					<b>Nature of death/disappearance (select one)</b>				
Struck the (e.g., boat, water):					Death – by drowning				
Was struck by a (e.g., boat, propeller):					Death – other likely cause (describe)				
Was exposed to carbon monoxide poisoning									
Received an electric shock					Disappeared and not yet recovered				
Other (describe):					Person was wearing lifejacket?		Yes	No	

For each question below, please provide answers IF APPLICABLE AND IF KNOWN, otherwise leave blank.							
<b>ACCIDENT DETAILS – YOUR BOAT OPERATOR</b>							
<b>OPERATOR INSTRUCTION</b>				<b>OPERATOR SAFETY MEASURES</b>			
Boating safety instruction completed <i>(select all that apply)</i>				On board, prior to accident, was operator wearing:			
None				A lifejacket?		Yes	No
State course				An engine cut-off switch <i>(Lanyard or wireless device)</i> if equipped?		Yes	No
USCG Auxiliary course				On board, prior to accident, was operator using:			
US Power Squadrons course				Alcohol?		Yes	No
Internet <i>(name of sponsoring organization)</i>				Drugs?		Yes	No
Other <i>(describe)</i>				Operator arrested for Boating Under the Influence?		Yes	No
				Weather reports consulted prior to accident?		Yes	No
<b>OPERATOR EXPERIENCE</b>							
Experience operating this type of boat <i>(select one)</i>							
0 to 10 hours		Over 10, up to 100 hours		Over 100, up to 500 hours		Over 500 hours	
<b>ACCIDENT DETAILS – OTHER KEY PEOPLE</b>							
Only report other key people not already documented as injured, died, disappeared or operator/owner of your boat. If more than two other key people to report, attach additional copies of this page.							
<b>NAME/ADDRESS</b>							
This other key person was a(n) <i>(select all that apply)</i>							
<input type="checkbox"/> Other boat operator <input type="checkbox"/> Other boat owner <input type="checkbox"/> Owner of other damaged property <input type="checkbox"/> Passenger on your boat <input type="checkbox"/> Witness							
First Name			MI	Last Name			
Street							
City			State	Zip	Phone		
Other boat name <i>(if any)</i>				Other boat registration # <i>(if any)</i>			
<b>NAME/ADDRESS</b>							
This other key person was a(n) <i>(select all that apply)</i>							
<input type="checkbox"/> Other boat operator <input type="checkbox"/> Other boat owner <input type="checkbox"/> Owner of other damaged property <input type="checkbox"/> Passenger on your boat <input type="checkbox"/> Witness							
First Name			MI	Last Name			
Street							
City			State	Zip	Phone		
Other boat name <i>(if any)</i>				Other boat registration # <i>(if any)</i>			

For each question below, please provide answers IF APPLICABLE AND IF KNOWN, otherwise leave blank.					
<b>YOUR BOAT OPERATOR</b>					
<b>NAME/ADDRESS</b>					
First Name	MI	Last Name			
Street					
City	State	Zip			
<b>AGE/GENDER/PHONE</b>					
Date of Birth <small>(mm/dd/yyyy)</small>	Age	Gender	Male	Female	Phone
<b>YOUR BOAT OWNER</b>					
If same as <i>your boat operator</i> SKIP rest of YOUR BOAT OWNER section.					
<b>NAME/ADDRESS/PHONE</b>					
First Name	MI	Last Name			
Street					
City	State	Zip	Phone		
<b>PERSON SUBMITTING THIS REPORT</b>					
If same as <i>your boat operator</i> OR <i>owner</i> , SKIP rest of PERSON SUBMITTING THIS REPORT section.					
<b>NAME/ADDRESS/PHONE/ROLE</b>					
First Name	MI	Last Name			
Street					
City	State	Zip	Phone		
<b>I was a(n) (select one)</b>					
<input type="checkbox"/>	Other person on board <i>this</i> boat				
<input type="checkbox"/>	Accident witness <i>not</i> on board <i>this</i> boat				
<input type="checkbox"/>	Other ( <i>describe</i> ):				
<b>SIGNATURE OF PERSON SUBMITTING THIS REPORT</b>					
<b>Your signature</b>				<b>Date (mm/dd/yyyy)</b>	
<p>An Agency may not conduct or sponsor and a person is not required to respond to an information collection, unless it displays a currently valid OMB Control Number.</p> <p>The Coast Guard estimates that the average burden for this report form is 30 minutes. You may submit any comments concerning the accuracy of this burden estimate or any suggestions for reducing the burden to: Commandant (CG-BSX-21), U.S. Coast Guard, Washington, DC 20593-0001 or Office of Management and Budget, Paperwork Reduction Project (1625-0003), Washington, DC 20503.</p>					





www.cgaux.org

# FLOAT PLAN

INSTRUCTIONS: Complete this plan before you go boating and leave it with a reliable person who can be depended upon to notify the Coast Guard, or other rescue agency, should you not return or check-in as planned. If you have a change of plans, or will be delayed, notify the person holding your Float Plan. Finally, close your plan by notifying the holder you have arrived home safely and if the holder has reported you overdue, notify all applicable rescue authorities of your safe return.



www.uscgboating.org

**Do NOT file this plan with the Coast Guard**

## VESSEL

### IDENTIFICATION:

Name & Hailing Port \_\_\_\_\_  
 Document / Registration No. \_\_\_\_\_ HIN \_\_\_\_\_  
 Year, Make & Model \_\_\_\_\_  
 Length \_\_\_\_\_ Type \_\_\_\_\_ Draft \_\_\_\_\_ Hull Mat. \_\_\_\_\_  
 Hull & Trim Colors \_\_\_\_\_  
 Prominent Features \_\_\_\_\_

### COMMUNICATION:

Radio Call Sign / Number \_\_\_\_\_  
 DSC MMSI No. \_\_\_\_\_  
 Radio-1: Type \_\_\_\_\_ Ch. / Freq. Monitored \_\_\_\_\_  
 Radio-2: Type \_\_\_\_\_ Ch. / Freq. Monitored \_\_\_\_\_  
 Cell / Satellite \_\_\_\_\_  
 Email \_\_\_\_\_

### PROPULSION:

Primary-- Type \_\_\_\_\_ Eng. \_\_\_\_\_ Fuel Capacity \_\_\_\_\_  
 Auxiliary--Type \_\_\_\_\_ Eng. \_\_\_\_\_ Fuel Capacity \_\_\_\_\_

### NAVIGATION: (Check all onboard)

Compass  Radar  GPS / DGPS  Depth Sounder  
 Charts  Maps  \_\_\_\_\_

## SAFETY & SURVIVAL

### VISUAL DISTRESS SIGNALS:

Electric Distress Light (night only)  
 Flag (day only)  
 Flare, Aerial (day & night)  
 Flare, Handheld (day & night)  
 Signal Mirror (day only)  
 Smoke (day only)

### AUDIBLE DISTRESS SIGNALS:

Bell  
 Horn  
 Whistle

### EPIRB:

UIN\* \_\_\_\_\_

### ADDITIONAL GEAR:

Anchor - Line length \_\_\_\_\_  Food for \_\_\_\_\_ days / person  
 Dewatering device  Water for \_\_\_\_\_ days / person  
 Exposure suits  \_\_\_\_\_  
 Fire Extinguisher  \_\_\_\_\_  
 Flashlight / Searchlight  \_\_\_\_\_  
 Raft / Dinghy  \_\_\_\_\_

## PERSONS ONBOARD

### OPERATOR:

Name \_\_\_\_\_  
 Address \_\_\_\_\_  
 City \_\_\_\_\_ State \_\_\_\_\_ Zip Code \_\_\_\_\_  
 Age \_\_\_\_\_ Gender \_\_\_\_\_ PFD  PLB UIN\* \_\_\_\_\_  
 Note \_\_\_\_\_  
 Float Plan Note \_\_\_\_\_

Has experience with:  this vessel;  the boating area(s).  
 Home Phone \_\_\_\_\_  
 Vehicle (Year, Make & Model) \_\_\_\_\_  
 Vehicle License No. \_\_\_\_\_ Trailer   
 Vehicle parked at \_\_\_\_\_

### PASSENGERS / CREW: (Identify all on board)

Name	Home Phone	Age	Gender	PFD	Note
1. _____	_____	_____	_____	<input type="checkbox"/>	_____
2. _____	_____	_____	_____	<input type="checkbox"/>	_____
3. _____	_____	_____	_____	<input type="checkbox"/>	_____
4. _____	_____	_____	_____	<input type="checkbox"/>	_____
5. _____	_____	_____	_____	<input type="checkbox"/>	_____
6. _____	_____	_____	_____	<input type="checkbox"/>	_____
7. _____	_____	_____	_____	<input type="checkbox"/>	_____
8. _____	_____	_____	_____	<input type="checkbox"/>	_____
9. _____	_____	_____	_____	<input type="checkbox"/>	_____
10. _____	_____	_____	_____	<input type="checkbox"/>	_____
11. _____	_____	_____	_____	<input type="checkbox"/>	_____
12. _____	_____	_____	_____	<input type="checkbox"/>	_____

Passenger PLB UIN\*  
 (Not listed in a specific order)

If you have a genuine concern for the safety or welfare of the persons onboard this vessel that have not returned or checked-in, in a reasonable amount of time, then follow the step-by-step instructions on the Boating Emergency Guide™ located on the last page of this Float Plan.

(\*) EPIRB and PLB registration required by Federal regulations. [www.beaconregistration.noaa.gov](http://www.beaconregistration.noaa.gov)



www.cgaux.org

## FLOAT PLAN continued

INSTRUCTIONS: Complete this plan before you go boating and leave it with a reliable person who can be depended upon to notify the Coast Guard, or other rescue agency, should you not return or check-in as planned. If you have a change of plans, or will be delayed, notify the person holding your Float Plan. Finally, close your plan by notifying the holder you have arrived home safely and if the holder has reported you overdue, notify all applicable rescue authorities of your safe return.

**Do NOT file this plan with the U.S. Coast Guard**



www.uscgboating.org

**CONTACTS**

Contact 1 \_\_\_\_\_ Phone Number \_\_\_\_\_

Contact 2 \_\_\_\_\_ Phone Number \_\_\_\_\_

Rescue Authority \_\_\_\_\_ Phone Number \_\_\_\_\_

**ITINERARY**

		DATE	TIME	LOCATION / WAYPOINT	MODE OF TRAVEL	REASON FOR STOP	CHECK-IN TIME
1	Depart						
	Arrive						
2	Depart						
	Arrive						
3	Depart						
	Arrive						
4	Depart						
	Arrive						
5	Depart						
	Arrive						
6	Depart						
	Arrive						
7	Depart						
	Arrive						
8	Depart						
	Arrive						
9	Depart						
	Arrive						
10	Depart						
	Arrive						
11	Depart						
	Arrive						
12	Depart						
	Arrive						
13	Depart						
	Arrive						
14	Depart						
	Arrive						
15	Depart						
	Arrive						
16	Depart						
	Arrive						
17	Depart						
	Arrive						
18	Depart						
	Arrive						
19	Depart						
	Arrive						
20	Depart						
	Arrive						
21	Arrive						

If you have a genuine concern for the safety or welfare of the persons onboard this vessel that have not returned or checked-in, in a reasonable amount of time, then follow the step-by-step instructions on the Boating Emergency Guide™ located on the last page of this Float Plan.

**USCG Float Plan - BOATING EMERGENCY GUIDE™**

**BEFORE YOU BEGIN** – This guide is designed to work either with or without a Float Plan. You will need the following items: 1) the Float Plan, if one was given to you; 2) a pen or pencil; 3) a clean sheet of paper or writing tablet; and 4) your local telephone directory.

**Step 1:** Do you have a genuine concern for the safety or welfare of any persons who have not returned or checked-in, in a reasonable amount of time?

If **yes**, then continue with **Step 2**. Otherwise **STOP** – no further action is required at this time.

**Step 2:** Were you given a prepared Float Plan by anyone on board the vessel?

If **yes**, then continue with **Step 3**. Otherwise, go to **Step 5**.

**Step 3:** Locate the Contacts at the top of page 2 on the Float Plan. Call Contact number 1...

IF CONTACT #1	THEN						
Answers phone	Take notes during your conversation. <ol style="list-style-type: none"> <li>Let the person know you are responding to a late return or check-in by the individuals designated on the Float Plan.</li> <li>Determine if the person you are talking to, or anyone else at that location, has recently had contact with anyone on the vessel, and when and where that contact occurred.</li> <li>Are you still concerned about the safety or welfare of any persons on board the vessel?</li> </ol> <table border="1"> <thead> <tr> <th>IF</th> <th>THEN</th> </tr> </thead> <tbody> <tr> <td>Yes</td> <td>Continue with <b>Step 4</b>.</td> </tr> <tr> <td>No</td> <td><b>STOP</b>. No further action is required.</td> </tr> </tbody> </table>	IF	THEN	Yes	Continue with <b>Step 4</b> .	No	<b>STOP</b> . No further action is required.
IF	THEN						
Yes	Continue with <b>Step 4</b> .						
No	<b>STOP</b> . No further action is required.						
Does not answer phone	Continue with <b>Step 4</b> .						

**Step 4:** Call Contact number 2...

IF CONTACT #2	THEN						
Answers phone	Take notes during your conversation. <ol style="list-style-type: none"> <li>Let the person know you are responding to a late return or check-in by the individuals designated on the Float Plan.</li> <li>Determine if the person you are talking to, or anyone else at that location, has recently had contact with anyone on the vessel, and when and where that contact occurred.</li> <li>Are you still concerned about the safety or welfare of any persons on board the vessel?</li> </ol> <table border="1"> <thead> <tr> <th>IF</th> <th>THEN</th> </tr> </thead> <tbody> <tr> <td>Yes</td> <td>Continue with <b>Step 6</b>.</td> </tr> <tr> <td>No</td> <td><b>STOP</b>. No further action is required.</td> </tr> </tbody> </table>	IF	THEN	Yes	Continue with <b>Step 6</b> .	No	<b>STOP</b> . No further action is required.
IF	THEN						
Yes	Continue with <b>Step 6</b> .						
No	<b>STOP</b> . No further action is required.						
Does not answer phone	Continue with <b>Step 6</b> .						

**Step 5:** Using the checklist below, jot down only what you know about each item:

**DO NOT SPECULATE.** Incorrect information may mislead Search and Rescue personnel; add to the overall search and rescue time; and adversely affect the outcome.

- Period of time the vessel has been overdue.
- Purpose of the trip or voyage.
- Description of vessel. (Type, size, color, features, etc.)
- Vessel's departure point and destination.
- Places the vessel planned to stop during transit.
- Navigation equipment aboard. (Examples: GPS, radar, compass, sounder, etc.)
- Number of persons aboard. Relevant characteristics such as dependability, reliability, etc.
- Was the vessel initially docked or moored or did a vehicle tow it to a launch point?
- License plate number and description of the tow vehicle and/or the passenger's transport vehicle.
- Communications equipment aboard, including type of radio and frequencies monitored, cellular or satellite telephone numbers of individuals, etc.
- Additional points of contact along the vessel's planned route.
- Operator and/or a passenger/crew member absolutely had to be back at the scheduled return time.
- Call your local Rescue Authority that responds to marine emergencies (Police, Sheriff, Constable, First responder, etc.).

Go to **Step 6-2**.

**Step 6:**

- Call the Rescue Authority contact at the top of page 2 on the Float Plan.
- Tell the dispatcher you are responding to a late return or check-in by the persons on board the vessel.
- The dispatcher will instruct you from there.

**Note:** The dispatcher will provide you with the necessary contact or agency connection to get a search and rescue mission started. This puts you in direct contact with the agency conducting the actual search and rescue, eliminating unnecessary middlemen.  
The dispatcher will tell you if he/she desires a follow-up call on the outcome of the rescue.

4. Continue with **Step 7**.

**Step 7:** Be patient... you've done everything you can possibly do for now. It is important to keep the telephone available so emergency personnel can contact you with additional information and/or questions concerning the search and rescue effort.

**STOP – End of Guide**

Provided as a courtesy by:  
S2 Yachts, Inc.  
Holland, MI  
(616) 392-7163  
Get a Vessel Safety Check before you go boating.



The USCG Float Plan is the official Float Plan of the U.S. Coast Guard and U.S. Coast Guard Auxiliary. For more information visit:

[www.floatplancentral.org](http://www.floatplancentral.org)



Problem	Cause and Solution
<b>Control Systems</b>	
<p><b>Hydraulic steering is slow to respond and erratic.</b></p>	<ul style="list-style-type: none"> <li>• Steering system is low on fluid. Fill and bleed system.</li> <li>• Steering system has air in it. Fill and bleed system.</li> <li>• A component in the steering system is binding. Check and adjust or repair binding component.</li> <li>• Engine steering cylinder is binding. Grease spindle.</li> </ul>
<p><b>The boat wanders and will not hold a course at cruise speeds.</b></p>	<ul style="list-style-type: none"> <li>• There could be air in the steering system. Fill &amp; bleed the system.</li> <li>• The engine steering tab is corroded or out of adjustment. Replace or adjust steering tab.</li> <li>• Engine steering cylinder is binding. Grease spindle.</li> </ul>
<p><b>The engine will not start with the shift control lever in neutral.</b></p>	<ul style="list-style-type: none"> <li>• The control cable is out of adjustment &amp; not activating the neutral safety cut out switch.</li> <li>• The shift control lever is not in the neutral detent. Try moving the shift lever slightly.</li> <li>• There is a loose wire on the neutral safety switch on the transmission. Inspect wires and repair loose connections.</li> <li>• The starter or ignition switch is bad.</li> </ul>
<b>Performance Problems</b>	
<p><b>Boat is sluggish and has lost speed and RPM.</b></p>	<ul style="list-style-type: none"> <li>• The boat may be need to have marine growth cleaned from hull and running gear.</li> <li>• Propeller may be damaged &amp; need repair.</li> <li>• Weeds or line around the propeller. Clean propeller.</li> <li>• Boat is overloaded. Reduce load.</li> <li>• Check for excessive water in the bilge. Pump out bilge &amp; find &amp; correct the problem.</li> <li>• The throttle adjustments has changed and the engine is not getting full throttle. Adjust the throttle cable.</li> </ul>

Problem	Cause and Solution
<p><b>The boat vibrates at cruising speeds.</b></p>	<ul style="list-style-type: none"> <li>• Propeller may be damaged and need repair.</li> <li>• The propeller or propeller shaft is bent. Repair or replace damaged components.</li> <li>• The running gear is fouled by marine growth or rope. Clean running gear.</li> <li>• The engine is not trimmed properly. Trim the engine.</li> </ul>
<p><b>Engine Problems</b></p>	
<p><b>The engine is running too hot.</b></p>	<ul style="list-style-type: none"> <li>• The engine raw water pick-up strainer up is clogged with marine growth. Clean pick-up.</li> <li>• The engine raw water pump impeller is worn or damaged. Repair the pump.</li> <li>• The engine thermostat is faulty and needs to be replaced.</li> </ul>
<p><b>The engine alternator is not charging properly.</b></p>	<ul style="list-style-type: none"> <li>• The battery cable is loose or corroded. Clean and tighten battery cables.</li> <li>• The alternator is not charging and must be replaced.</li> <li>• The engine battery isolator in the charging system is not working properly. Replace the isolator.</li> <li>• The battery is defective. Replace the battery.</li> <li>• The alternator breaker may be in the OFF position.</li> </ul>
<p><b>The engine suddenly will not operate over 2000 RPM.</b></p>	<ul style="list-style-type: none"> <li>• The engine emergency system has been activated. The onboard computer has sensed a problem and has limited the RPM to protect the engine. Find &amp; correct the problem.</li> <li>• The tachometer is bad and needs to be replaced.</li> </ul>

Problem	Cause and Solution
<p><b>The engine is loosing RPM. The boat is not overloaded and the hull bottom and running gear are clean and in good condition.</b></p>	<ul style="list-style-type: none"> <li>• The engine may be having a problem with a sticky anti-siphon valve, located in the fuel line near the fuel tank, that is restricting the fuel flow. Remove &amp; clean or replace the anti-siphon valve.</li> <li>• The remote gasoline fuel filter could be dirty. Inspect and replace the fuel filter.</li> <li>• The primary fuel filter on the engine may be dirty. Inspect and replace the fuel filter.</li> <li>• The electronic engine control system on the engine is malfunctioning. Repair the engine control system.</li> <li>• The fuel injection system on the engine is malfunctioning. Repair the fuel injection system.</li> </ul>
<p><b>Accessory Problems</b></p>	
<p><b>The livewell pump runs, but does not pump water.</b></p>	<ul style="list-style-type: none"> <li>• The strainer on the intake scoop is clogged preventing the water from getting to the pump. Put the boat in reverse to clean the strainer.</li> <li>• There is an air lock in the system. Run the boat above 15 m.p.h. and the pick-up scoop will force the air lock past the pump and prime the system.</li> <li>• The thru-hull valve is not open. Open valve.</li> <li>• The valve in the livewell is not open. Open the valve in the livewell.</li> </ul>
<p><b>The automatic float switch on the bilge pump raises but does not activate the pump.</b></p>	<ul style="list-style-type: none"> <li>• The in-line fuse near the battery switch has blown. Replace the fuse.</li> <li>• The pump impeller is jammed by debris. Clean pump impeller housing.</li> <li>• The pump is defective. Replace pump.</li> </ul>





The fresh water system must be disinfected before first use and yearly at the beginning of each season. A clean sanitized fresh water system will greatly reduce the risk of developing coliform bacteria or other disease-causing organisms (pathogens) and will help protect the health of everyone onboard.



## WARNING

**DISINFECT THE ENTIRE FRESH (POTABLE) WATER SYSTEM PRIOR TO USE AND YEARLY AT THE BEGINNING OF EACH SEASON. FAILURE TO DO SO CAN RESULT IN DEVELOPING COLIFORM BACTERIA OR OTHER DISEASE-CAUSING ORGANISMS (PATHOGENS) IN THE WATER SYSTEM. CONSUMPTION OF CONTAMINATED WATER COULD RESULT IN SEVERE PERSONAL INJURY OR DEATH.**

**Follow this procedure to disinfect the fresh water system, kill bacteria that may be present, and prepare the system for operation:**

Note: The fresh water system may be filled with nontoxic potable water antifreeze. If antifreeze was not used, skip to step 7.

1. Turn both water heater valves to the normal operation position (**Figure A-1**).
2. Open all faucets (hot & cold), setting single faucets to the warm position.
3. Switch ON the FRESH WATER PUMP breaker(s), located on the DC Distribution Panel. The pumps are self-priming.
4. When anti-freeze stops flowing out of the faucets, switch the pump breaker(s) OFF. Do not close faucets.
5. Fill the fresh water tank with clean, fresh water. The fill fitting for the water tank is on the deck amidships, labeled WATER. The tank should be filled until water runs out of the vent located on the hull side just below the fill.
6. Keeping all faucets open, switch the FRESH WATER PUMP breaker(s) ON and empty the water tank. When the water tank is empty turn the pump breaker(s) OFF.
7. Repeat steps 5 and 6 until all nontoxic potable water antifreeze is removed from the system.

**FRESH WATER SYSTEM**

- 8. Ensure the water system, including the water heater and pump(s), is drained completely.
- 9. Close all faucets.

CAUTION

**Notify all persons aboard that the fresh water system is being sanitized. Do not allow anyone to drink from the fresh water system during the sanitizing process.**

- 10. Prepare a chlorine sanitizing solution: in a container with 1 gallon of fresh water, mix 1/4 cup of Clorox® or Purex® regular unscented household bleach (5% sodium hypochlorite solution) for each 15 gallons of water tank capacity (**Table A-1**).

*Table A-1: Tank capacity vs. cups of bleach*

Water Tank Capacity	Cups of Bleach
15 Gal	1/4 Cup
30 Gal	1/2 Cup
45 Gal	3/4 Cup
60 Gal	1 Cup
75 Gal	1-1/4 Cups
90 Gal	1-1/2 Cups
105 Gal	1-3/4 Cups
120 Gal	2 Cups
135 Gal	2-1/4 Cups
150 Gal	2-1/2 Cups

- 11. Fill the fresh water tank halfway with clean, fresh water.
- 12. Pour the sanitizing solution into the water tank through the deck WATER fill fitting.
- 13. Fill the remainder of the tank with clean, fresh water. The tank should be filled until water runs out of the vent. (See step 5.)
- 14. Switch ON the FRESH WATER PUMP breaker(s).
- 15. At each faucet, run about 1/2 gallon of water out of each tap (hot and cold), then close the tap. You should be able to smell chlorine out of each tap.
- 16. Switch OFF the FRESH WATER PUMP breaker(s).
- 17. **Allow the chlorine sanitizing solution to sit in the system for three (3) hours.** A shorter time period will require a greater concentration of chlorine sanitizing solution to disinfect the water system.
- 18. Switch ON the FRESH WATER PUMP breaker(s).

## FRESH WATER SYSTEM

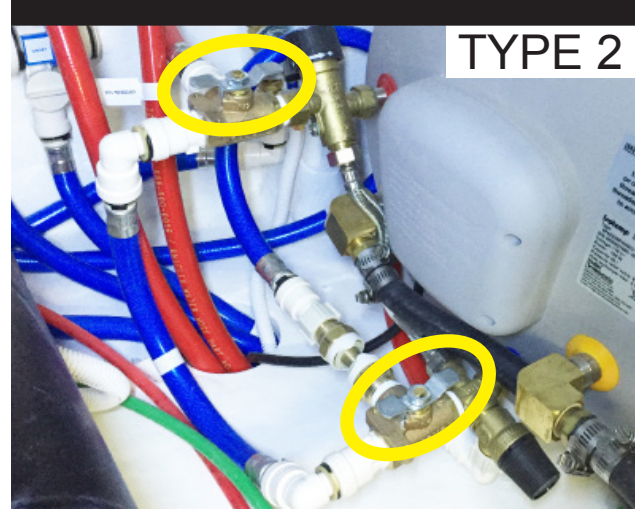
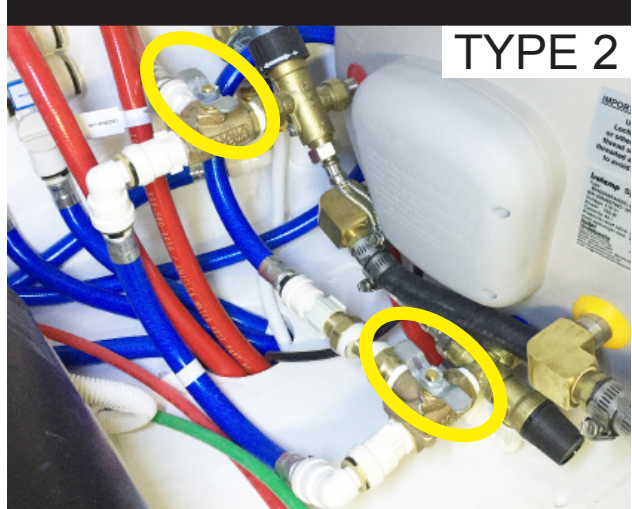
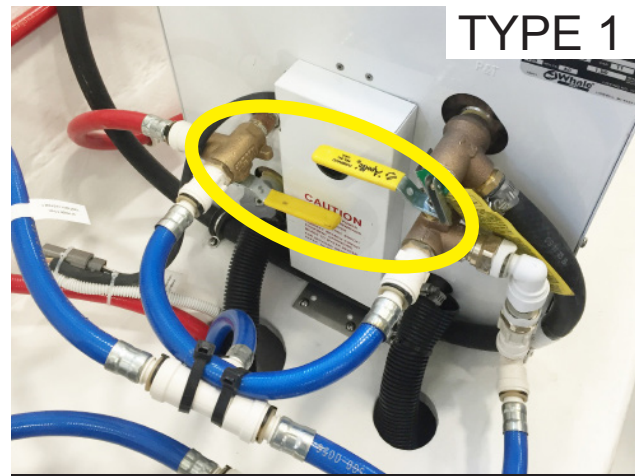
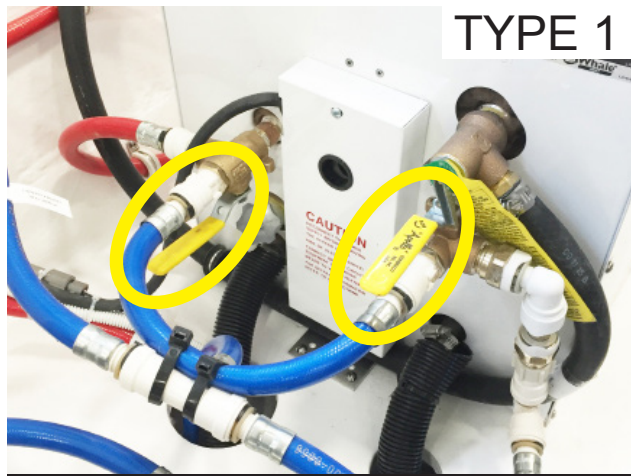

*Figure A-1: Water heater valves in normal operation position*

*Figure A-2: Water heater valves in bypass position*

19. Drain the chlorine sanitizing solution by opening all faucets (hot & cold), setting single faucets to the warm position, and empty the water tank. When the water tank is empty turn the pump breaker(s) OFF.
20. Ensure the water system, including the water heater and pump(s), is drained completely.
21. Fill the fresh water tank with clean, fresh water. The tank should be filled until water runs out of the vent. (See step 5.)

## FRESH WATER SYSTEM

22. Keeping all faucets open, switch the FRESH WATER PUMP breaker(s) ON and empty the water tank. When the water tank is empty turn the pump breaker(s) OFF.
23. Repeat steps 21 and 22.
24. Final fill: Fill the fresh water tank with clean, fresh water. The tank should be filled until water runs out of the vent. (See step 5.)
25. Turn the FRESH WATER PUMP breaker(s) ON
26. Open each faucet. When a smooth flow of water is observed from each hot and cold tap, close the faucet. When all faucets are closed, the pumps will shut off as the system pressure increases. Any air should now be purged from the system. Leave the FRESH WATER PUMP breaker(s) ON.

**The fresh water system is now commissioned and ready for use.**

To remove excessive chlorine taste or odor that might remain in the system, do the following:

1. Ensure the water tank has enough available capacity to accept 10 additional gallons. If there is ample room in the tank, proceed to step 3, below.
2. Drain at least 10 gallons of water out of the system so the following vinegar solution will have room to be added. To do this switch ON the FRESH WATER PUMP breaker(s) and open a faucet. When at least 10 gallons has been drained, close the faucet and turn the pump breaker(s) OFF.
3. Prepare a solution of one (1) quart vinegar to five (5) gallons fresh water.
4. Pour the vinegar solution into the water tank through the deck WATER fill fitting.
5. Repeat steps 3 and 4.
6. Allow the vinegar solution to agitate in the tank for 24 hours.
7. Switch ON the FRESH WATER PUMP breaker(s).
8. Drain the vinegar solution by opening all faucets (hot & cold), setting single faucets to the warm position, and empty the water tank. When the water tank is empty turn the pump breaker(s) OFF.
9. Close all faucets.

## FRESH WATER SYSTEM

10. Fill the fresh water tank with clean, fresh water. The fill fitting for the water tank is on the deck amidships, labeled WATER. The tank should be filled until water runs out of the vent located on the hull side just below the fill.
11. Turn the FRESH WATER PUMP breaker(s) ON
12. Open each faucet. When a smooth flow of water is observed from the hot and cold tap, close the faucet. When all faucets are closed, the pumps will shut off as the system pressure increases. Any air should now be purged from the system. Leave the FRESH WATER PUMP breaker(s) ON.
13. Repeat if necessary.

## FRESH WATER SYSTEM

This page intentionally left blank.



# **Tiara**<sup>®</sup>

**Y A C H T S**

725 E 40th Street, Holland, MI 49423 | 616.392.7163  
tiarayachts.com



**AMERICAN MADE**