



Owner's Guide

Installation & Operation

Fryer
HFR Series



Hestan Commercial Corporation

3375 E. La Palma Ave
Anaheim, CA 92806
(888) 905-7463

RETAIN THIS MANUAL FOR FUTURE REFERENCE



P/N 002137 REV B

IMPORTANT FOR YOUR SAFETY

THIS MANUAL HAS BEEN PREPARED FOR PERSONNEL QUALIFIED TO INSTALL GAS EQUIPMENT, WHO SHOULD PERFORM THE INITIAL FIELD START-UP AND ADJUSTMENTS OF THE EQUIPMENT COVERED BY THIS MANUAL.

POST IN A PROMINENT LOCATION THE INSTRUCTIONS TO BE FOLLOWED IN THE EVENT THE SMELL OF GAS IS DETECTED. THIS INFORMATION CAN BE OBTAINED FROM THE LOCAL GAS SUPPLIER.

IMPORTANT

IN THE EVENT A GAS ODOR IS DETECTED, SHUT DOWN UNITS AT MAIN SHUTOFF VALVE AND CONTACT THE LOCAL GAS COMPANY OR GAS SUPPLIER FOR SERVICE.

FOR YOUR SAFETY

DO NOT STORE OR USE GASOLINE OR OTHER FLAMMABLE VAPORS OR LIQUIDS IN THE VICINITY OF THIS OR ANY OTHER APPLIANCE.

WARNING

IMPROPER INSTALLATION, ADJUSTMENT, ALTERATION, SERVICE OR MAINTENANCE CAN CAUSE PROPERTY DAMAGE, INJURY OR DEATH. READ THE INSTALLATION, OPERATING AND MAINTENANCE INSTRUCTIONS THOROUGHLY BEFORE INSTALLING OR SERVICING THIS EQUIPMENT.

IN THE EVENT OF A POWER FAILURE, DO NOT ATTEMPT TO OPERATE THIS DEVICE.

DO NOT OPERATE THE FRYER WITHOUT A TIPPING RESTRAINT IN PLACE. DO NOT ATTEMPT TO MOVE THE FRYER WITH OIL/SHORTENING, ESPECIALLY WHEN HOT. IT COULD SPLASH/SPILL AND CAUSE SEVERE BURNS. DRAIN THE FRYER BEFORE MOVING.

CALIFORNIA PROPOSITION 65 - WARNING



WARNING This product can expose you to chemicals including carbon monoxide, which is known to the State of California to cause cancer.

For more information, go to www.P65Warnings.ca.gov.

Table of Contents

Section 1:	Installation	4
	Installation Procedure.....	4
	Uncrating.....	4
	Location	4
	Clearances	4
	Placing Appliance	4
	Leveling.....	4
	Riser Installation.....	5
	Statutory Regulations	5
	United States of America	5
	Canada	5
	Appliances Equipped with Casters	6
	Gas Supply.....	7
	Gas Pressure Regulator	8
	Ventilation Air / Flue Connections.....	9
	Model / Serial / Rating Plate Location	9
Section 2:	Operating Instructions	10
	Lighting and Shutdown Instructions.....	10
Section 3:	Cleaning and Maintenance.....	11
	Gas-Fired Appliances	11
	Service.....	12
	Troubleshooting Guide.....	12

Installation

Installation Procedure

Uncrating

Check the crate for any possible damage sustained during transit. Carefully remove the appliance, removing all packing material, again check for damage. Any damage to the appliance must be reported to the carrier immediately.

Location

Proper placement of the appliance will ensure operator convenience and satisfactory performance. Adequate clearance must be maintained so that the combustion and ventilation air is not obstructed for proper operation. A minimum front clearance of 36 inches (914 mm) must be provided for servicing. The appliance must be kept free and clear of combustible materials.

Clearances

The following minimum clearances must be followed:

Model	COMBUSTIBLE		NON-COMBUSTIBLE	
	BACK	SIDE	BACK	SIDE
Fryer	6"	6"	0"	0"

NOTE: For use on combustible floor with 6" legs, or for 6" non-combustible curb mount with 3" recess.

Placing Appliance

Place the appliance in the required position and level by means of the adjustable legs. The surface on which the appliance is to be installed must be capable of adequately supporting the weight of the appliance.

Leveling

For proper and safe operation, each appliance must be level.

6" legs are mounted using four hex-head bolts per leg and each leg is adjustable simply by turning the inner cylinder leg, clockwise to lower and counter-clockwise to elevate.

NOTE: A carpenter's level can be used on the plate shelf for left to right leveling.

Riser Installation

- 1) Remove back panel from riser assembly by removing mounting screws.
- 2) Remove the four bolts at the rear of the appliance holding on the side panels (two on each side, see diagram below).
- 3) Place riser on support brackets on back of the appliance.
- 4) Re-install the four bolts into the back of the appliance through the riser channels, do not tighten.
- 5) Attach the bottom supports with supplied bolts, two on each side.
- 6) Tighten the four bolts that attach riser to appliance.
- 7) Tighten the four bolts that attach riser to bottom supports.
- 8) Re-install back cover.

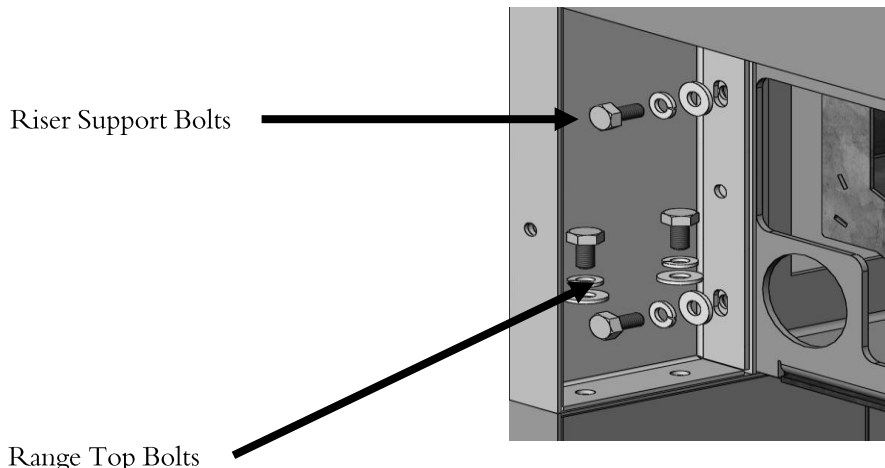

NOTE: Failure to re-install back cover could cause improper venting of exhaust gases/heat from the appliance, creating soot that clogs the burner(s) and flue and/or creates a temperature risk to cabinet and components.

Statutory Regulations (Install Codes)

The installation of this appliance must be carried out by a properly trained and qualified installer and in accordance with the relevant regulations, codes of practice and the related publications of the Country, State, County and City of destination.

United States of America

- 1) Local Codes
- 2) In the absence of local codes, installation must conform to the National Fuel Gas Code, ANSI Z223.1/NFPA 54, or the Natural Gas and Propane Installation Code, CSA B149.1, as applicable. Copies may be obtained from the American Gas Association, Inc., on their web site: <http://www.aga.org/>
- 3) National Electrical Code, ANSI/NFPA-70, or latest edition. Copies may be obtained from the National Fire Protection Association, on their web site: <http://www.nfpa.org/>
- 4) Vapor Removal From Cooking Equipment, NFPA-96, or latest edition. Copies may be obtained from the National Fire Protection Association, on their web site: <http://www.nfpa.org/>

Canada

- 1) Local Codes
- 2) CSA B149.1 Natural Gas and Propane Installation Code.
- 3) CSA C22.1 Canadian Electrical Code
- 4) CSA C22.2 Canadian Electrical Code

Canadian codes can be found on the CSA website: <http://www.csa.ca>

Appliances Equipped with Casters

NOTE: The front casters of the appliance are equipped with brakes to limit movement of the appliance without depending on the connector and any quick-disconnect device or its associated piping to limit the appliance movement.

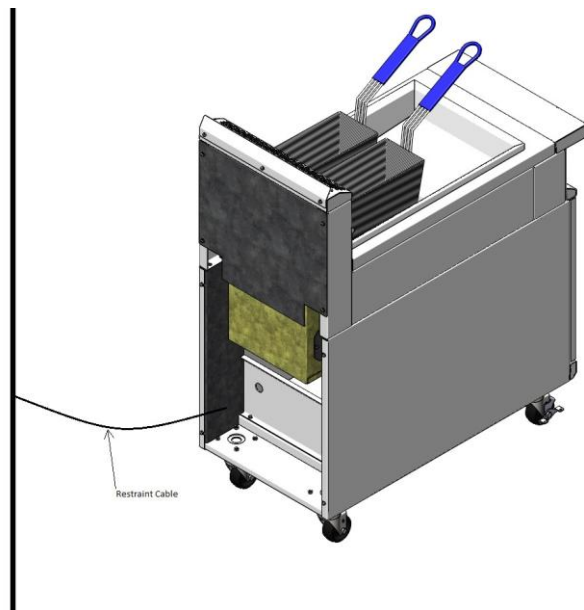

Fig. 1

- 1) The installation shall be made with a connector that complies with the Standard for Connectors for Movable Gas Appliances, ANSI Z21.69/CSA 6.16, (or latest edition), and a quick-disconnect device that complies with Standard for Quick Disconnect of Use with Gas Fuel, ANZI Z21.41/CSA 6.9, (or latest edition).
- 2) Adequate means must be provided to limit the movement of the appliance without depending on the connector and the quick-disconnect device or its associated piping to limit the appliance movement. (Fig. 1)

NOTE: Please be aware, required strain relief restraint cable is attached to a bracket, and if disconnection of the restraint is necessary, be sure to reconnect the restraint after the appliance has been returned to its original installed position.

Gas Supply

The local gas authority should be consulted at the installation planning stage in order to establish the availability of an adequate supply of gas and to ensure that the meter is adequate for the required flow rate. The pipe work from the meter to the appliance must be an appropriate size.

All fixed (non-mobile) appliances must be fitted with an accessible upstream gas shutoff valve as a means of isolating the appliance for emergency shut off and for servicing. A union or similar means of disconnection must be provided between the gas-cock and the appliance.

A manually operable valve must be fitted to the gas supply to the kitchen to enable it to be isolated in an emergency. Wherever practical, this shall be located either outside the kitchen or near an exit in a readily accessible position.

Where it is not practical to do this, an automatic isolation valve system should be fitted which can be operated from a readily accessible position near the exit.

In locations where the manual isolation valve is fitted or the automatic system can be reset this notice must be posted:

“ALL DOWNSTREAM BURNER AND PILOT VALVES MUST BE TURNED OFF PRIOR TO ATTEMPTING TO RESTORE THE SUPPLY. AFTER EXTENDED SHUT OFF, PURGE BEFORE RESTORING GAS”

NOTE: Before assembly and connection, check gas supply.

Gas Supply Notes

- 1) The type of gas for which the unit is equipped is stamped on the rating plate, see locations on page 9. Connect a unit stamped “NAT” only to natural gas and stamped “LP” only to propane gas.
- 2) If it is a new installation, have the gas authorities check the meter size and piping to assure that the unit is supplied with the necessary amount of gas supply and pressure to operate the unit(s).
- 3) Make certain new piping and connections have been made in a clean manner and have been purged so that piping compound, chips, etc. will not clog pilots, valves, gas regulator, or burners. Use pipe joint compound approved for natural and liquefied petroleum gases.
- 4) The natural gas pressure coming into the regulator should be 7” WC or .25 psig (1.75kpa) and 4” WC .14 psig (1.0 kpa) coming out of the regulator. For liquid propane gas pressure coming into the regulator should be 11” WC or .4 psig (2.75kpa) and 10” WC .36 psig (2.5kpa) coming out of the regulator.

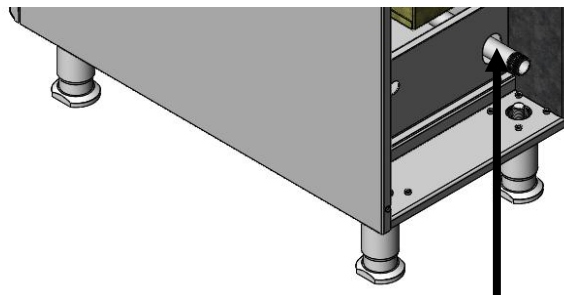

1" NPT Rear Gas Connection

Gas Pressure Regulator

A gas pressure regulator must be installed to regulate the proper flow of gas to the appliance. The regulator must be installed between the main gas supply line to the unit shut off valve and the appliance and must be accessible for servicing. Proper sizing of the regulator is extremely important, check the BTU rating of the appliance or appliances being regulated by the regulator.

NOTE: Contact the factory for regulator sizing when multiple appliances are being installed in a line up or island suite configuration and are interconnected using the front manifold connections.

NOTE: Gas pressure should be checked when the unit is installed and all other equipment on the same line is on. The operating gas pressure must be the same as that specified on the rating plate. If necessary, pressure adjustment may be made at the pressure regulator.

The appliance and its individual shutoff valve must be disconnected from the gas supply piping system during any pressure testing of that system where pressures are in excess of .5 psig (3.45kpa).

When test pressures are .5 psig (3.45kpa) or less, the appliance must be isolated from the gas supply system by closing its individual manual shutoff valve.



Prior to lighting, check all joints in the gas supply line for leaks. Use soap and water solution. Do not use an open flame. After piping has been checked for leaks, all piping receiving gas should be fully purged to remove air.

Ventilation Air / Flue Connections

The following notes are intended to give general guidance. For detailed recommendations, refer to the applicable codes in the Country, State, County and City of installation.



Do not obstruct the flow of combustion and ventilation air.

Proper ventilation is critical for optimum performance. The ideal method of ventilating gas fired equipment is the use of properly designed canopy that should extend six inches (152mm) beyond all sides of the appliance (s) and six feet six inches (1981mm) above the floor. Information on the construction and installation of ventilating hoods may be obtained from the standard for "Vapor Removal from Cooking Equipment," NFPA No. 96 (latest edition), available from the National Fire Protection Association, on their web site: <http://www.nfpa.org/>.

A strong exhaust will create a vacuum in the room. For an exhaust vent to work properly, replacement air must be equal to the amount of air exhausted. An imbalance between exhaust and replacement air can cause degradation in the appliance's performance.

All gas burners and pilots need sufficient air to operate. Large objects should not be placed in front of the appliance(s) that would obstruct the flow of air into the front.

NOTICE: In the Commonwealth of Massachusetts all gas appliances vented by either mechanical systems or ventilation hoods shall comply with 248 CMR interlocking requirements.

Model / Serial / Rating Plate Locations

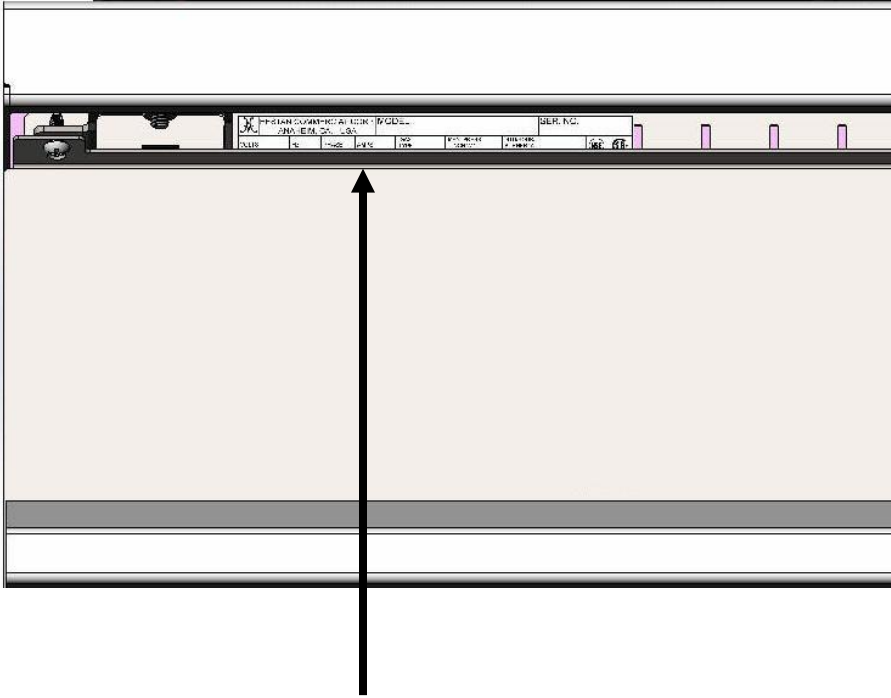

Fryers
Rating plate will be located above the front panel

Operating Instructions

Lighting Instructions

Fryer Section

Before turning the burner on

LIGHTING INSTRUCTIONS are located on the inside of the cabinet door.

1. Fill the vessel with liquid oil up to the "Level" marking.
2. Do not operate fryer without oil in the vessel.
3. Do not overfill the vessel.

LIGHTING

1. Set thermostat dial and gas valve dial to the "OFF" position. Wait 5 minutes and turn gas valve dial to "PILOT" position.
2. Depress the gas valve dial for 5-15 seconds to purge the gas line, and then light the pilot with a log lighter or match. Continue to depress the dial for about 30 seconds or until the pilot remains lit. Release the dial, the pilot should remain lit. Repeat as needed until the pilot remains lit.
3. To light the burners, turn the gas valve dial to the "ON" position and turn thermostat to the desired temperature.
4. For daily shutoff, turn the thermostat dial and gas valve dial to the "OFF" position.

Pilot

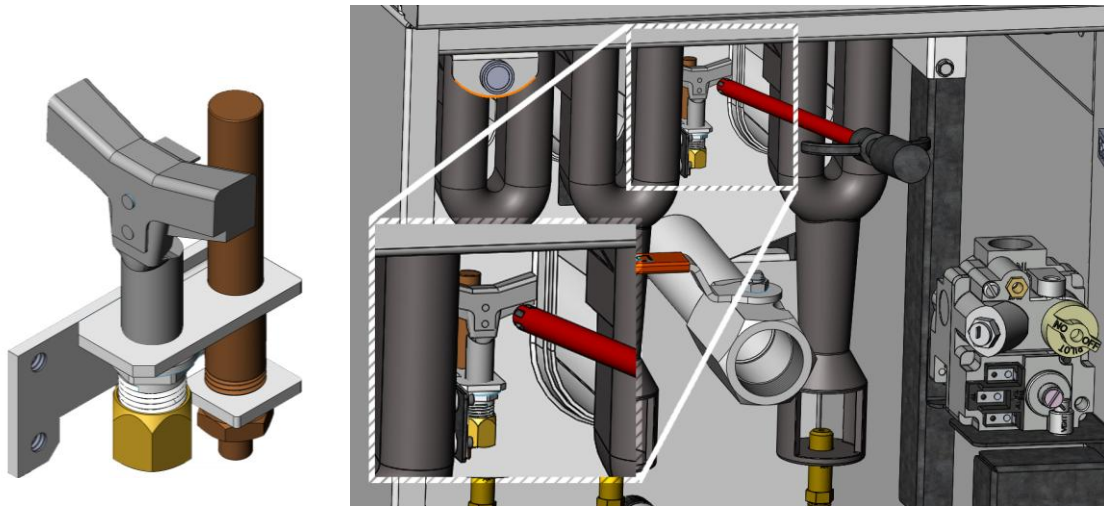

WARNING

A 5 minute complete shutoff period is required before the appliance is re-lighted

FRYING WITH SHORTENING

To deep fry with shortening, always start with an empty and/or cleaned-out tank and melt the shortening on the stove – carefully pouring it into the tank. That way, you can be sure the shortening is in full contact with the fryer tank metal – eliminating the potential of weld fracture from dry firing.

For daily shutoff: If you do not want to relight the pilot the next day, turn thermostat dial "OFF" and gas valve dial to the "PILOT" position, pilot(s) will remain on.

Cleaning and Maintenance

Gas Fired Appliances

1. Shut down the fryer by turning the thermostat and pilot valve to the OFF position.
2. Disconnect the restraining device before moving the appliance for cleaning and servicing.
3. Drain the fryer into a filtered pan or steel container. Flush out sediment at the bottom of fryer with liquid oil.
4. Close the drain valve and fill the vessel with a mixture of boil-out solution and water.
5. Relight the pilot and turn on the burners.
6. When the solution starts to boil, turn off the thermostat and let the vessel soak to soften deposits and/or carbon spots, for approximately one hour.
7. Drain off the solution. Scrub the insides with a brush and rinse thoroughly.
8. Repeat steps 4-7 if necessary.
9. Wipe dry with soft towels and refill with oil/shortening.

NOTE: STAINLESS STEEL PARTS - Do not use steel wool, abrasive cloths, cleaners or powders to clean Stainless Steel surfaces. All stainless Steel parts should be wiped regularly with hot soapy water during the day and a Stainless Steel cleaner at end of the day. To remove encrusted materials, soak in hot water to loosen the material - then use a wood or nylon scraper.



All water must be removed before adding oil or shortening. Not doing so can result in splattering of hot oil causing severe burns and burn hazard.



DO NOT DRY-FIRE; operating the unit without liquid is an extreme fire hazard and will cause irreparable damage such as gas leaks, scorched surfaces and burnt components. Dry firing is typically done after cleaning when the end user wants to dry out the tank the "easy" way. It is a major cause of tank damage in the industry.



1. Do not drain the oil while it's hot; wait until it cools before emptying. Rapid change in temperature causes stress fractures and tears at the seams of the tank.
2. Do not use acidic cleaners; use only boil-out solution. Acid can cause erosion to metal and in due time can cause a leak in the tank.
3. Solid shortening must be liquefied before filling the tank. The tank walls must have liquid against it in order to transfer heat and avoid overheating and stressing the metal to the point of a tear.
4. Do not rinse off a hot tank with cold water. Always allow it to cool first.
5. Do not use sharp tools to clean the fryer; it can leave metal debris in the tank.
6. Keep your tank clean. Check for debris buildup at the bottom of the tank, and never allow too much build-up to occur. Excessive build up reduces the efficiency of the fryer.

Service

All warranty and non-warranty repairs should be performed by qualified service personnel. To locate an authorized service agent in your area contact your dealer, local representative, or the manufacturer.

Hestan Commercial Products
(888) 905-7463

Troubleshooting guide

Symptom	Check
Burner will not light	Unit is not connected to gas; visually check that the unit is connected to gas. Thermostat is not turned on or make sure it is set to a proper temperature setting
Pilot is not burning or won't stay lit	Pilot orifice obstructed or dirty Vent plugged on regulator or regulator installed improperly Negative pressure or unbalanced ventilation in kitchen creating drafts Low gas pressure to unit Faulty pilot generator on gas valve
Thermostat is set to very low temperature	Check temperature setting and adjust to proper or desired values
Fryer does not reach selected temperatures	Unit may not have been operating long enough Unit preheats to 350°F in about ten minutes Thermostat may be defective Too little gas pressure or gas line is obstructed
General frying problems	Make sure unit is set to recommended temperatures of foods being fried Thermostat out of calibration
Gas Odor	Loose or broken gas line Ruptured pressure regulator Burner not installed properly Poor combustion, air fuel mixture not adjusted properly or obstructed/dirty burner ports Pilot not lit
Burner not working well/lazy or yellow flame	Gas pressure incorrect / incorrect regulator Orifice sized incorrectly Burner ports are obstructed or dirty Poor combustion, air fuel mixture not adjusted properly