

STANDARD FEATURES

HESTAN

CHARBROILER

- ◆ High performance, top grade stainless steel tubular burner, each up to 40,000Btu/hour, per 12" wide section
- ◆ Each burner individually controlled
- ◆ Reversible cast iron broiler grate with channels to direct grease to trough (*Patented*)
- ◆ Cantilevered stainless steel cooking system : each section can be individually adjusted vertically at 3 broiling positions . Low profile design to allow island installation
- ◆ Modular sections to allow various types of broiler grates
- ◆ Standard Marine Grade 12 GA stainless steel radiant for even heat distribution
- ◆ Available from 18" to 72" wide configurations
- ◆ Heavy gauge welded body construction

Reversible Cast Iron Grates

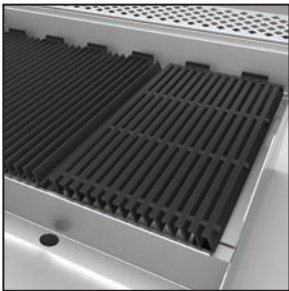

Optional Searing Plate

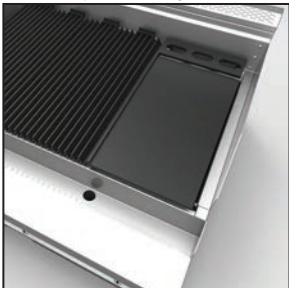

Stainless Steel Rod Grate

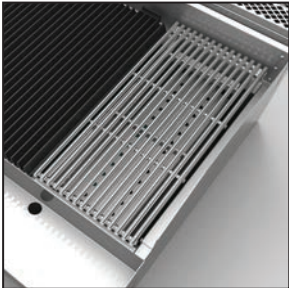

- ◆ Heavy gauge stainless steel, fully welded, charbroiler firebox
- ◆ 1-1/4" front gas manifold
- ◆ Standing pilot ignition system with front accessible pilot adjustment
- ◆ Zamak die cast knobs and bezels with set screw (*Patented*)
- ◆ Stainless steel front, sides, 4.5" plate shelf, and bottom
- ◆ 9" tall Low Riser

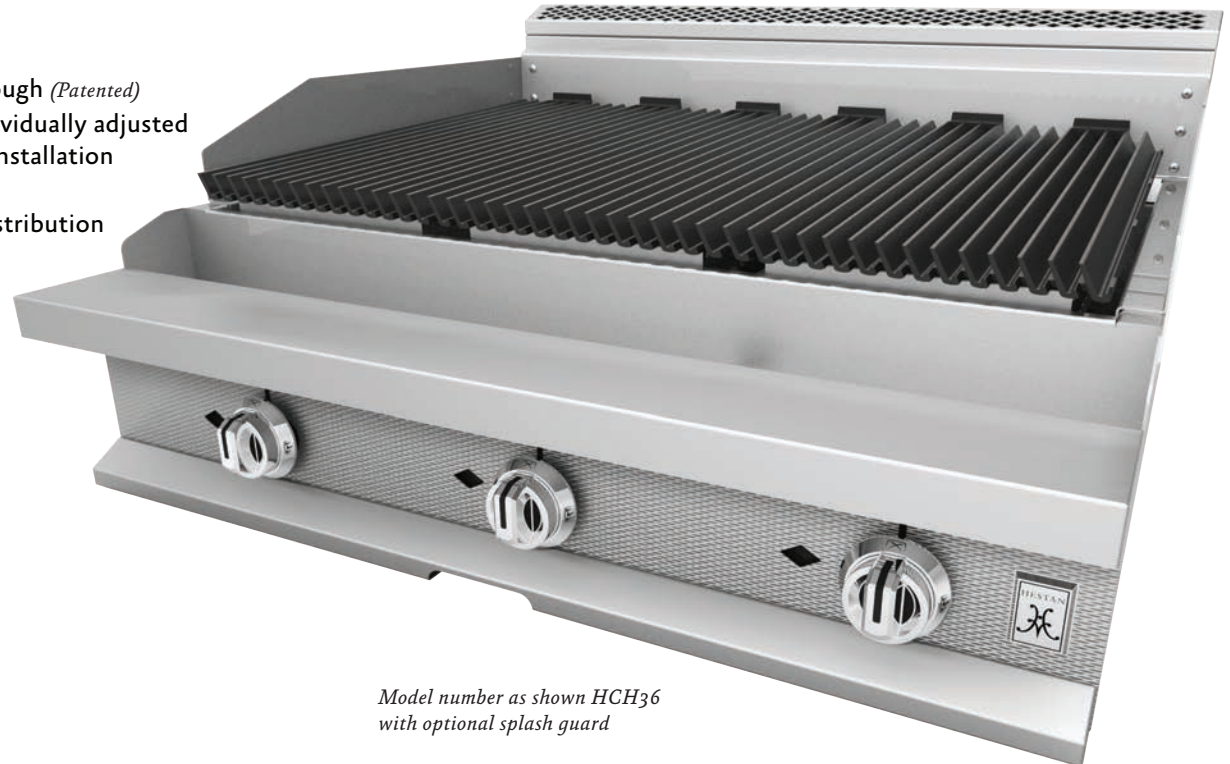

Model number as shown HCH36
with optional splash guard

OPTIONS

- ◆ Heavy duty stainless steel rod grates for fish or vegetables
- ◆ Heavy duty 3/8" thick steel searing plate
- ◆ Removable stainless steel splash guard (sides & rear) at 4.5" high
- ◆ Customizable Marquise Accented™ valve panel (*Patented* / contact sales department for available options)
- ◆ Manifold caps and covers
- ◆ 1" rear gas supply connection
- ◆ Front manifold union connections
- ◆ Stainless steel back cover
- ◆ Common plate shelf up to 108" wide
- ◆ Extended plate shelf (6" or 8")
- ◆ Belly bar with 1" space or extended to accommodate 1/9 condiment pans
- ◆ 4" legs for countertop models
- ◆ Risers: Tall or Mid

Note: Salamander, Cheesemelter, Island Trim, casters, and shelves are not recommended for fryers as a safety precaution



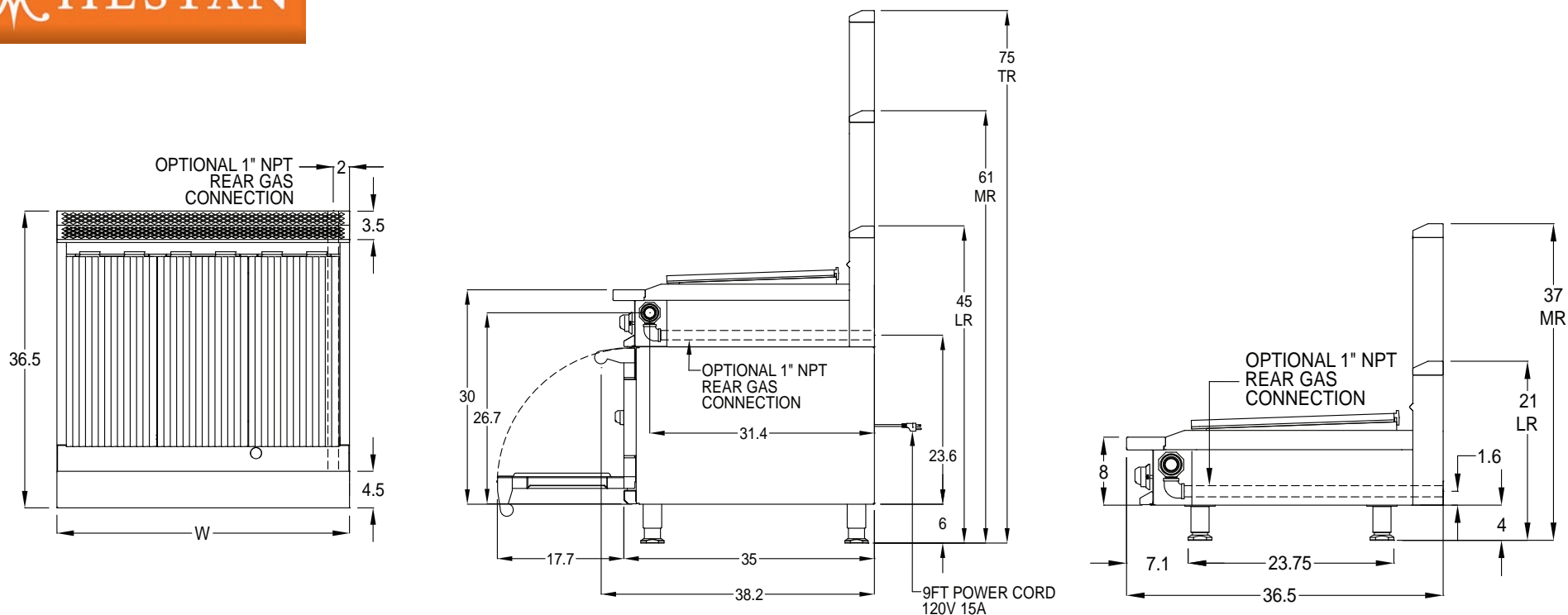

Model	Description	Gas [Btu/HR]	Approx SHP WT	Width (W)
HCH18	18" Charbroiler Rangetop	60,000	200	18"
HCH24	24" Charbroiler Rangetop	80,000	250	24"
HCH30	30" Charbroiler Rangetop	100,000	300	30"
HCH36	36" Charbroiler Rangetop	120,000	360	36"
HCH48	48" Charbroiler Rangetop	160,000	500	48"
HCH60	60" Charbroiler Rangetop	200,000	620	60"
HCH72	72" Charbroiler Rangetop	240,000	720	72"

ELECTRICAL : No electrical requirement

GAS : 1-1/4" front manifold, capped or connectable to adjacent equipment. 1" male NPT rear gas connection available. Minimum gas supply is 7" water column for natural gas and 11" for propane. Operating pressure at the manifold is 5" water column for natural gas and 10" for propane. All units require a regulated gas supply.

VENTILATION : The product is required to be installed under an exhaust hood.



Note: Hestan Commercial products are not approved or recommended for residential use. Hestan Commercial Corporation reserves the right to change materials and specifications without notice. Specify type of gas when ordering. Specify altitude when above 2,000 ft.



CONTACT US: www.hestancommercial.com

phone 888.905.7463

3375 E. La Palma Ave., Anaheim, CA 92806