

STANDARD FEATURES

 HESTAN

SALAMANDER

- ◆ Unique wide - open chassis design for maximum visibility from all directions
- ◆ Heavy duty gas - powered infrared burner, up to 30,000 Btu/hour, with intense and efficient infrared heat
- ◆ Heavy duty Inconel burner screen with optimum combustion efficiency, durability, and flame stability
- ◆ Tilted burner design for heat deflection and rear flue system to direct heat away from the user and controls
- ◆ Durable attachment design to allow complete horizontal movement of the broiler along the length of the riser (*Patented*)

Vertical Mechanism



Horizontal Mechanism



Infrared Inconel Screen Burner



- ◆ Front mounted ON-OFF gas valve for optimum flame control and stability
- ◆ Elevation rack mechanism for smooth 5" vertical operation, infinite height adjustment, and maximum heating control (*Patented*)
- ◆ Full extension concealed horizontal glide system for smooth operation and easy access
- ◆ Removable stainless steel drip tray for ease of cleaning
- ◆ Range mount (R) model with Tall Riser, Wall mount (W) model with mounting bracket, or Counter (C) model with 4" countertop legs
- ◆ Available in 24" and 36" wide configurations
- ◆ Heavy gauge welded body construction
- ◆ Standing pilot ignition system with front accessible pilot adjustment
- ◆ Zamak die cast knobs and bezels with set screw (*Patented*)
- ◆ Full width Marquise Accented™ stainless steel rack handle (*Patented*)
- ◆ Stainless steel front, sides, top and bottom
- ◆ 3/4" manifold and rear gas supply connection



Model number as shown HSMW36



AutoQuotes



AUTODESK
REVIT



BIM | CAD | MOBILE

OPTIONS

- ◆ Customizable Marquise Accented™ valve panel (*Patented* / contact sales department for available options)
- ◆ Removable side shields (2). Units may be mounted adjacent to one another with 0" side clearance



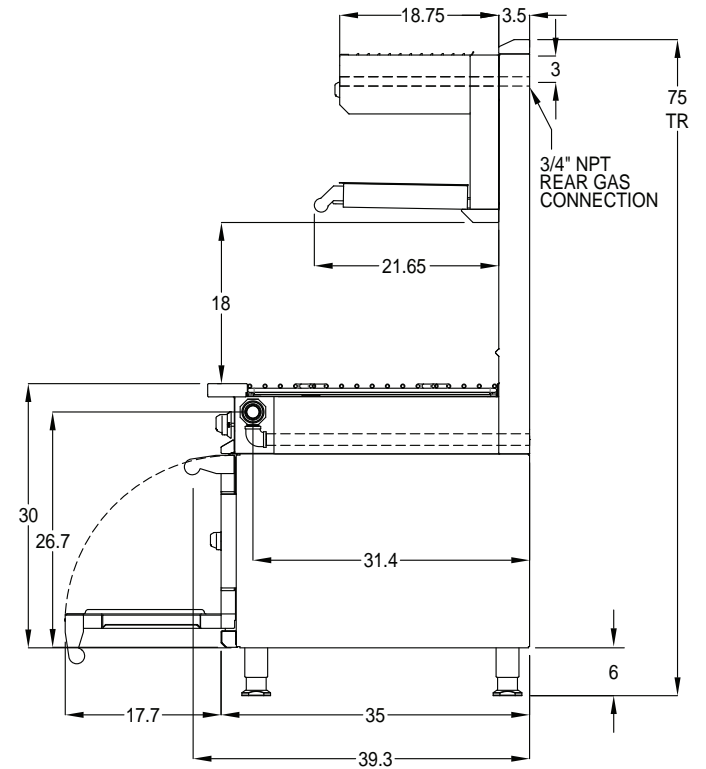
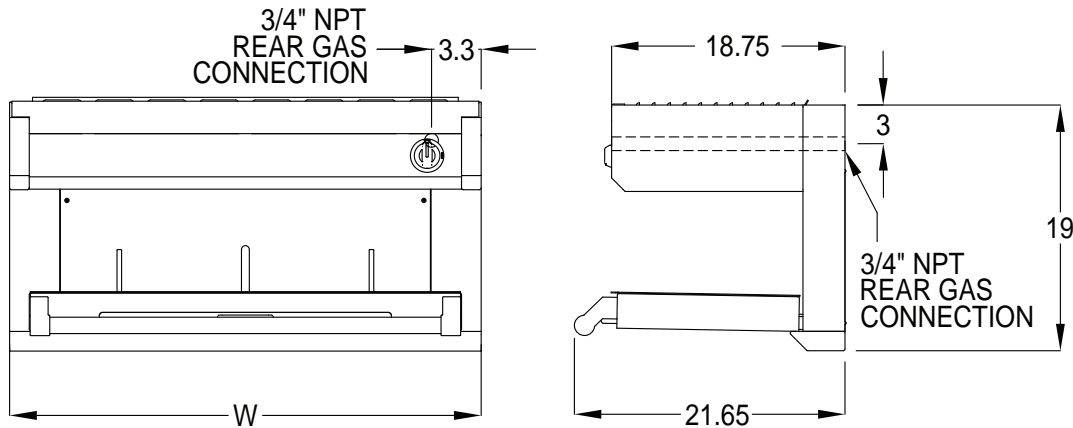

Model	Description	Gas [Btu/HR]	Approx SHP WT	Width (W)
HSMR24	24" Salamander Range mount	20,000	200	24"
HSMW 24	24" Salamander Wall mount	20,000	170	24"
HSMC 24	24" Salamander Counter model	20,000	190	24"
HSMR 36	36" Salamander Range mount	30,000	300	36"
HSMW 36	36" Salamander Wall mount	30,000	250	36"
HSMC36	36" Salamander Counter model	30,000	275	36"

ELECTRICAL : No electrical requirement

GAS : Minimum gas supply is 7" water column for natural gas and 11" for propane. Operating pressure at the manifold is 5" water column for natural gas and 10" for propane. All units require a regulated gas supply

VENTILATION : The product is required to be installed under an exhaust hood.

Note: Hestan Commercial products are not approved or recommended for residential use. Hestan Commercial Corporation reserves the right to change materials and specifications without notice. Specify type of gas when ordering. Specify altitude when above 2,000 ft.

