

STANDARD FEATURES



WORK TOP

- ◆ Heavy gauge welded body construction
- ◆ Sound insulated work top surface
- ◆ Available from 12" to 48" wide configurations
- ◆ Stainless steel front, sides, bottom, and 4.5" plate shelf
- ◆ 9" tall Low Riser

Insulated Work Top

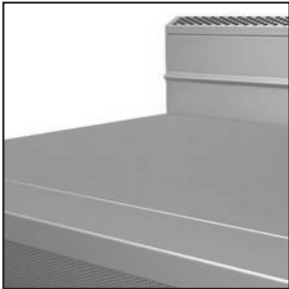

Welded Construction



Marquise Accent



OPTIONS

- ◆ Customizable Marquise Accented™ front panel (*Patented* / contact sales department for available options)
- ◆ Customized widths
- ◆ Manifold caps and covers
- ◆ 1-1/4" front gas manifold with side union connections
- ◆ Stainless steel back cover
- ◆ Common plate shelf up to 108" wide
- ◆ Extended plate shelf (6" or 8")
- ◆ Belly bar with 1" space or extended to accommodate 1/9 condiment pans
- ◆ 4" legs for countertop models
- ◆ Risers : Tall, Mid, or Island Trim
- ◆ Shelves : single or double, solid, tubular or mixed

Model number as shown HWT36



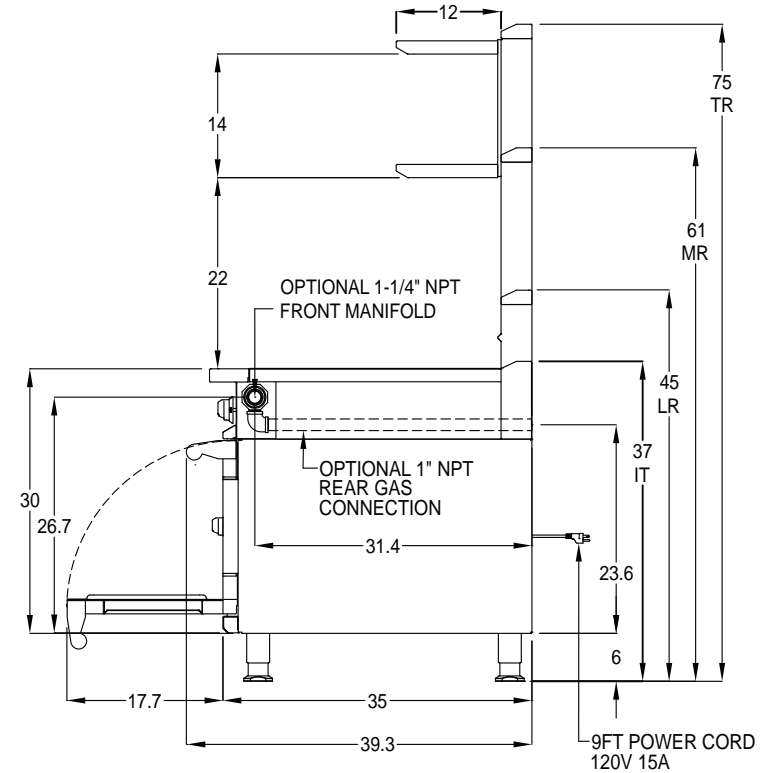
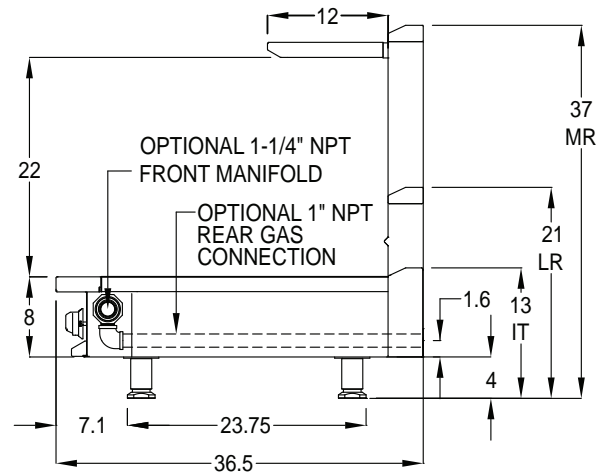
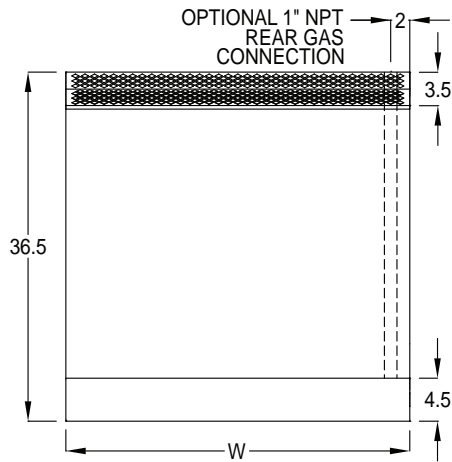

Model	Description	Approx SHP WT	Width (W)
HWT12	12" wide Work Top	80	12"
HWT18	18" wide Work Top	100	18"
HWT24	24" wide Work Top	150	24"
HWT30	30" wide Work Top	165	30"
HWT36	36" wide Work Top	180	36"
HWT48	48" wide Work Top	200	48"

ELECTRICAL : No electrical requirement

GAS : No gas requirement

VENTILATION : No ventilation requirement



Note : Hestan Commercial products are not approved or recommended for residential use. Hestan Commercial Corporation reserves the right to change materials and specifications without notice.