

## STANDARD FEATURES



## COUNTERHEIGHT UNIT

- ◆ Each product on 28" tall modular legs
- ◆ Heavy duty 2.5" diameter stainless steel tubular modular legs with bottom shelf
- ◆ Modular design to allow maximum flexibility and endless possible configurations
- ◆ Available product offerings:
  - Sealed Burner Rangetops (*Patented*)
  - Thermostatic Griddles
  - Manual Griddles
  - Charbroilers (*Patented*)
  - Hot Tops
  - French Tops (*Patented*)
  - Plancha
  - Open Burners
  - Split Tops
  - Step Ups

Stainless Steel Tubular Legs

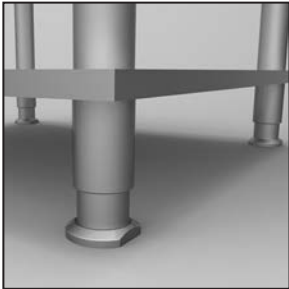

36" Size Shown



72" size shown with optional casters



- ◆ Available from 12" to 72" wide configurations
- ◆ Heavy gauge welded body construction
- ◆ 1-1/4" NPT front gas manifold with side union connections
- ◆ Sealed Burner Rangetops have single point re-ignition direct spark system and modules at each burner position. Flame rectification means igniter will continue to spark until the burner flame is established
- ◆ Other products with standing pilot ignition system with front accessible pilot adjustment
- ◆ Zamak die cast knobs and bezels with set screws (*Patented*)
- ◆ Stainless front, sides, 4.5" plate shelf, and bottom
- ◆ 9" tall Low Riser
- ◆ 6" height adjustable legs

### OPTIONS

- ◆ Customizable Marquise Accented™ valve panel (*Patented* / contact sales department for available options)
- ◆ Flame failure safety valves
- ◆ Manifold caps and covers
- ◆ 1" NPT rear gas supply connection
- ◆ Front manifold union connections
- ◆ Stainless steel back cover
- ◆ Common plate shelf up to 108" wide
- ◆ Extended plate shelf (6" or 8")
- ◆ Belly bar with 1" space or extended to accommodate 1/9 condiment pans
- ◆ Risers : Mid or Island Trim
- ◆ Shelves : single, solid, or tubular
- ◆ 6" height adjustable casters. Front casters with brakes



Model number as shown HMB366 and HEL36



COUNTERHEIGHT UNIT

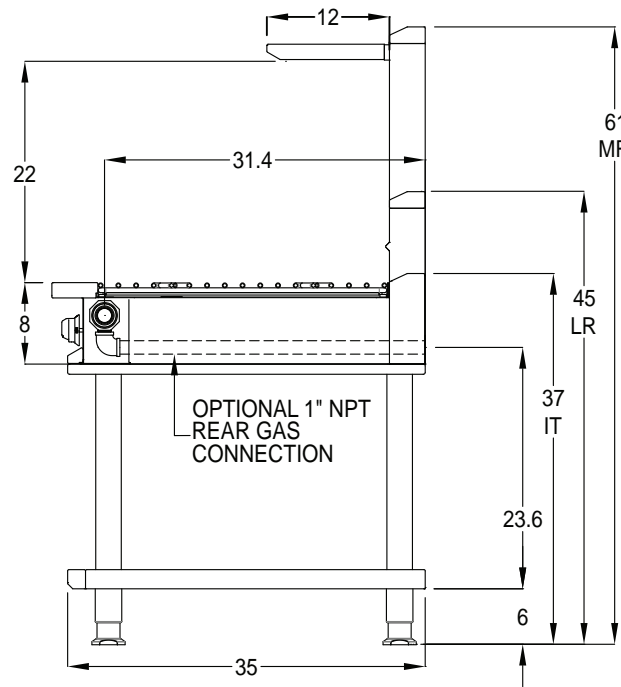
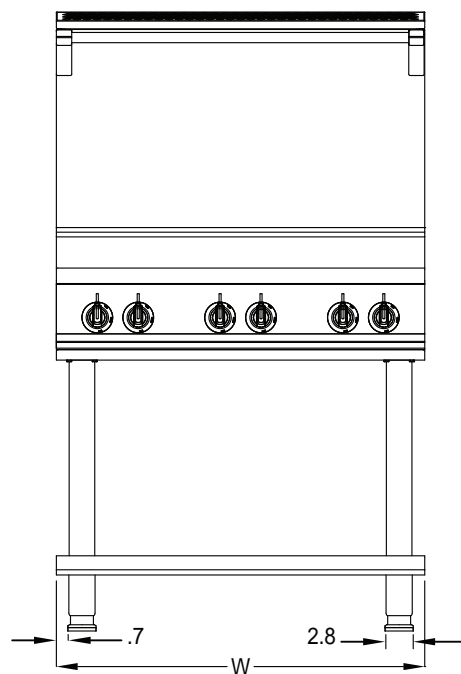

Model	Description	Approx SHP WT	Width (W)
HEL12	12" wide Extended Legs	35lbs	12"
HEL18	18" wide Extended Legs	55lbs	18"
HEL24	24" wide Extended Legs	65lbs	24"
HEL30	30" wide Extended Legs	75lbs	30"
HEL36	36" wide Extended Legs	85lbs	36"
HEL48	48" wide Extended Legs	108lbs	48"
HEL60	60" wide Extended Legs	128lbs	60"
HEL72	72" wide Extended Legs	148lbs	72"

**ELECTRICAL** : For Sealed Burner Rangetops only : 120V, 60Hz, 15A, 1 phase. Other models : no electrical requirement

**GAS** : 1-1/4" front manifold, capped or connectable to adjacent equipment. 1" male NPT rear gas connection available. Minimum gas supply is 7" water column for natural gas and 11" for propane. Operating pressure at the manifold is 5" water column for natural gas and 10" for propane. All units require a regulated gas supply.

**VENTILATION** : The product is required to be installed under an exhaust hood.



*Note: Hestan Commercial products are not approved or recommended for residential use. Hestan Commercial Corporation reserves the right to change materials and specifications without notice. Specify type of gas when ordering. Specify altitude when above 2,000 ft.*