

## STANDARD FEATURES



## THERMOSTATIC GRIDDLE

- ◆ Heavy duty 1" thick Blanchard ground steel griddle plate
- ◆ High performance, top grade stainless steel tubular burner, each up to 25,000Btu/hour, per 12" wide section
- ◆ Each burner is controlled with a combination thermostatic safety valve
- ◆ 2" high stainless steel splash guard (sides and rear)
- ◆ Stainless steel front grease trough
- ◆ Available from 12" to 72" wide configurations
- ◆ Heavy gauge welded body construction
- ◆ Fully enclosed, spill-proof grease drawer for easy cleaning

Grease Trough and Drawer

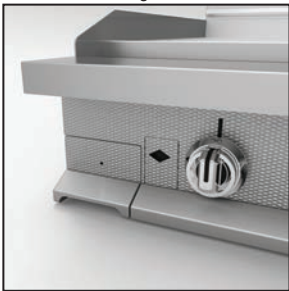

- ◆ 1-1/4" front gas manifold
- ◆ Standing pilot ignition system with front accessible pilot adjustment
- ◆ Zamak die cast knobs and bezels with set screws (*Patented*)
- ◆ Stainless steel front, sides, 4.5" plate shelf, and bottom
- ◆ 9" Low Flue Riser

Optional Mirror Finish Plate



Optional Grooved Plate



## OPTIONS

- ◆ 6" high splash guard
- ◆ Chrome / mirror finish griddle plate
- ◆ Grooved griddle plate
- ◆ Customizable Marquise Accented™ valve panel (*Patented* / contact sales department for available options)
- ◆ Manifold caps and covers
- ◆ 1" rear gas supply connection
- ◆ Front manifold union connections
- ◆ Stainless steel back cover
- ◆ Common plate shelf up to 108" wide
- ◆ Extended plate shelf (6" or 8")
- ◆ Belly bar with 1" space or extended to accommodate 1/9 condiment pans
- ◆ 4" legs for countertop models
- ◆ Risers: Tall, Mid, or Island Trim
- ◆ Shelves: single or double, solid, tubular or mixed



Model number  
as shown HTG36



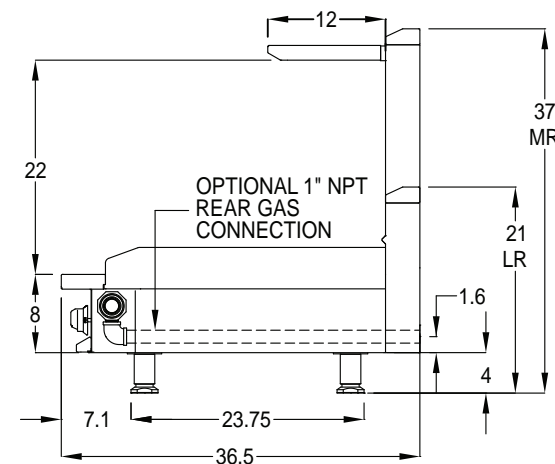
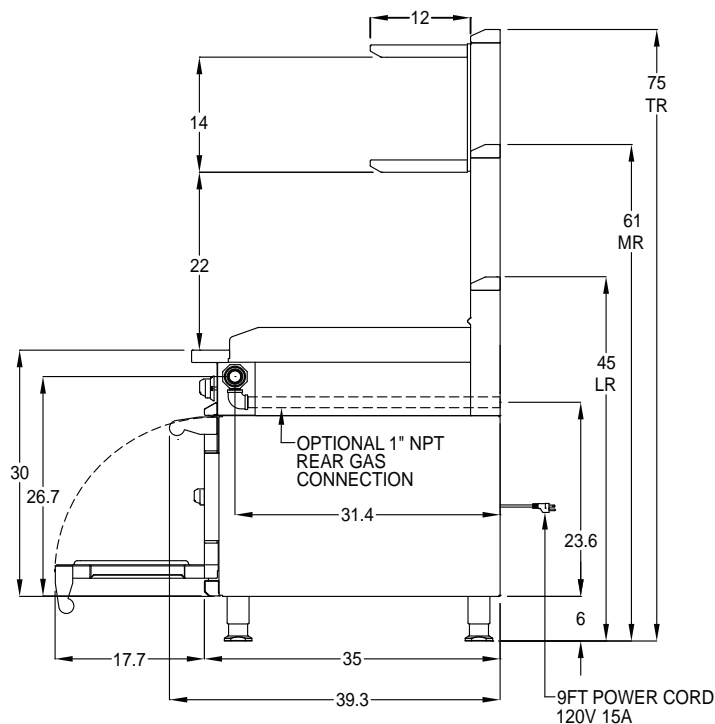
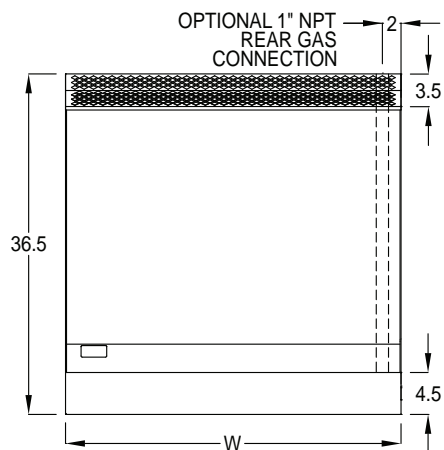

Model	Description	Gas [Btu/HR]	Approx SHP WT	Width (W)
HTG 12	12" Thermostatic Griddle	16,500	150	12"
HTG18	18" Thermostatic Griddle	25,000	200	18"
HTG24	24" Thermostatic Griddle	50,000	275	24"
HTG30	30" Thermostatic Griddle	62,500	300	30"
HTG36	36" Thermostatic Griddle	75,000	360	36"
HTG48	48" Thermostatic Griddle	100,000	540	48"
HTG60	60" Thermostatic Griddle	125,000	600	60"
HTG72	72" Thermostatic Griddle	150,000	720	72"

**ELECTRICAL :** No electrical requirement

**GAS :** 1-1/4" front manifold, capped or connectable to adjacent equipment. 1" male NPT rear gas connection available. Minimum gas supply is 7" water column for natural gas and 11" for propane. Operating pressure at the manifold is 5" water column for natural gas and 10" for propane. All units require a regulated gas supply.

**VENTILATION :** The product is required to be installed under an exhaust hood.



Note: Hestan Commercial products are not approved or recommended for residential use. Hestan Commercial Corporation reserves the right to change materials and specifications without notice. Specify type of gas when ordering. Specify altitude when above 2,000 ft.



**CONTACT US:** [www.hestancommercial.com](http://www.hestancommercial.com)

phone 888.905.7463

3375 E. La Palma Ave., Anaheim, CA 92806