



E ERECTASTEP®

Portable Series - IBC



OWNER'S MANUAL

Portable Series - IBC

THIS PRODUCT AND/OR IT'S COMPONENTS MAY BE COVERED BY ONE OR MORE PATENTS, SEE WWW.ERECTASTEP.COM/PATENTS

E ERECTASTEP®

219 Safety Avenue / Andrews, SC 29510 / Ph 888 878 1839 / Fx 843 264 8584

PORTABLE PLATFORM SYSTEM



WARNING! READ CAREFULLY AND UNDERSTAND ALL INSTRUCTIONS BEFORE STARTING INSTALLATION. FAILURE TO FOLLOW ALL INSTRUCTIONS MAY RESULT IN DEATH OR SERIOUS PERSONAL INJURY.

IMPORTANT

- Equipment should not be altered or modified from its original design without consultation with the manufacturer.
- Equipment which is damaged or becomes damaged during use, handling, or shipping should be set aside and not used.



- **WARNING! Failure to anchor unit properly with the correct layout dimensions can result in product damage not covered under warranty – units 42” and taller are not designed to be self supported without anchor bolts. Failure to secure all fasteners may result in death or serious personal injury.**
- Do not assemble unit off of anchor bolts and then lift onto them. System should only be assembled in its final location. Never move an assembled system.



- **WARNING! Handrail mount angles must be used where designated in the instruction manual. Failure to use handrail mount angles where designated may cause equipment to fail and may result in death or serious personal injury.**

TORQUE DATA:

All ½” bolted connections = 678 in-lbs. (56 ft-lbs.) lubricated or 904 in-lbs. (75 ft-lbs.) dry +/-10%.

For 5/8” anchor bolts = 900 in-lbs. (75 ft-lbs.) lubricated or 1080 in-lbs. (90 ft-lbs.) dry +/-10%.

Use of impact wrenches NOT sanctioned.



- **WARNING! After a usage period of 60-90 days, check all fasteners to ensure connections are secure. Periodic inspection is recommended to insure all fasteners are secured. Failure to secure all fasteners may result in death or serious personal injury.**



- **WARNING! This product can expose you to chemicals including cadmium, which is known to the State of California to cause cancer, and/or birth defect or other reproductive harm.**
For more information, go to www.P65warnings.ca.gov

PORTABLE PLATFORM SYSTEM

ASSEMBLY CRITERIA

Verify proper installation according to ErectASStep – Portable Series installation manual. In addition, make sure to check the following specifically.

- Ensure all anchor bolts are installed properly at the stair base and supports.
- Ensure supports are vertically plumb.
- Ensure platform and steps are level.
- Ensure all bolts are properly tightened according to ErectASStep – Portable Series installation manual.
 - No impact wrenches are to be used – tighten all bolts manually with wrench.

PORTABLE SERIES PLATFORM SYSTEM



Thank you for purchasing an ErectAStep Portable Series Metal Stair Unit!

Your new ErectAStep stair unit has been manufactured using the latest technologies, along with only the highest quality materials to ensure dependable service for years to come.

Please take care, to follow all configuration guidelines and installation instructions to ensure your new Stair unit performs as designed. Please note: design limitations can exist with respect to required supports, adequate footings, and the prescribed application. Please seek the help of licensed professional engineer if further support and/or foundation requirements are in question.

For further questions or concerns, please contact Customer Support at [888.878.1839](tel:888.878.1839)

Thanks again for choosing ErectAStep!

COMPONENTS

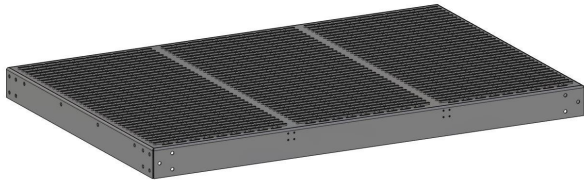

PLATFORM



4FT HANDRAIL



6FT HANDRAIL



STAIR UNIT



SUPPORTS

- Min 2 people are recommended for assembly.
- Forklifts may be required for assembly.

PLATFORM COMPONENT

Platform Order Part Number:
Platform 4 Ft x 6 Ft – Part #90219

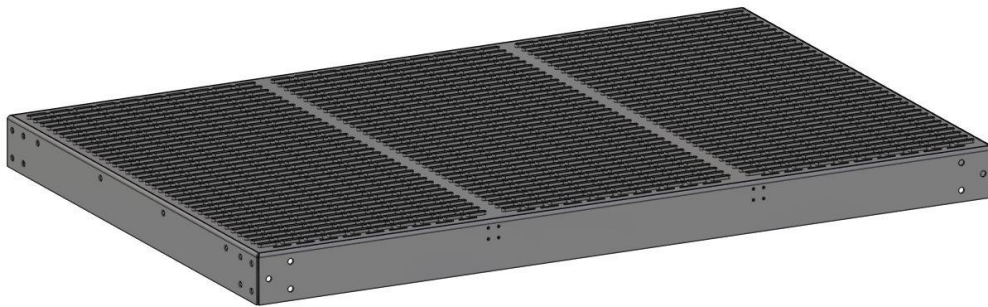

PLATFORM

PLATFORM HANDRAIL COMPONENTS

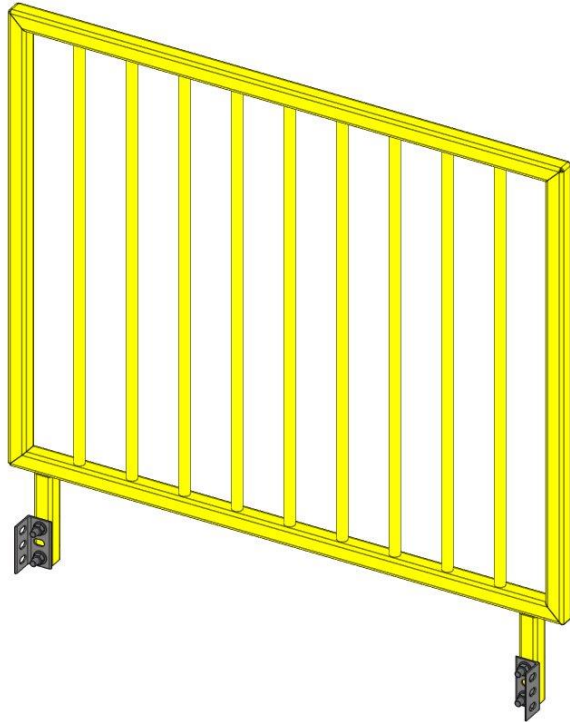

Platform Handrail Order Part Number:

Platform Handrail 4 Ft– Part #90222

Platform Handrail 6 Ft– Part #90221

PLATFORM HANDRAIL

STAIR COMPONENTS



STAIR UNIT

Stair Unit Order Part Number:

Stair 28" – Part #90224

Stair 35" – Part #90225

Stair 42" – Part #90230

Stair 49" – Part #90231

Stair 56" – Part #90232

Stair 63" – Part #90233

SUPPORT COMPONENTS



Portable Support

Order Part Numbers:

28"/35" – Part #90228 (Set of 4)

42"/49" – Part #90229 (Set of 4)

56"/63" – Part #90238 (Set of 4)

Cross Braces Required for 56"/63"
Supports (included in part #90238)

SUPPORTS

SYSTEM ANCHOR LAYOUT

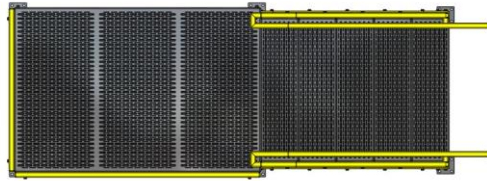

PLAN VIEW

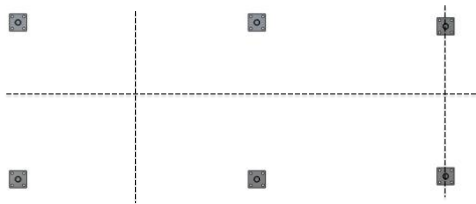

PAD LAYOUT

ANCHOR BOLT POSITION

- **NOTICE – Anchors are required for system 42” and taller. Anchors are optional for systems less than 42”.**
- **NOTICE - Do not assemble unit off of anchor bolts and then lift onto them. System should only be assembled in its final location. Never move an assembled system.**
- Anchor bolt positions should be laid out by mathematically calculating positions of anchors. (see component anchor layout)
- Layout area for location of your ErectASStep Portable Series system using measuring tape and chalk lines, keeping anchor lines square and parallel.
- Drill or wet set anchor bolts in the mathematically correct location prior to assembly. Follow any curing procedures recommended by your concrete/anchor bolt supplier.
- Using a level slab/foundation is recommended for anchoring the ErectASStep Portable unit to achieve a good contact point between the bottom of the stairs/supports and the concrete in lieu of utilizing leveling anchors and shims.
- Once pad layout is complete and you are ready to assemble unit, continue with instructions. Assemble unit on anchor bolts starting with supports and platform, then stairs and handrails.

COMPONENT ANCHOR LAYOUT

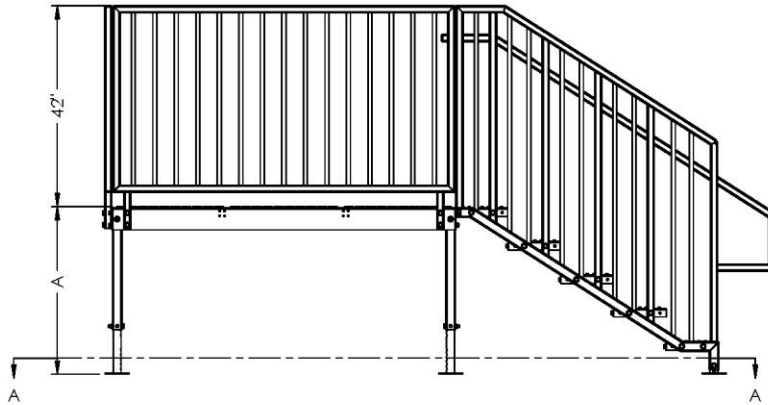

Stair Unit and Supports

5/8" diameter anchor bolts required for 3/4" diameter holes in base plate.

Anchors required for systems 42" and taller.

Anchors are optional for systems less than 42".

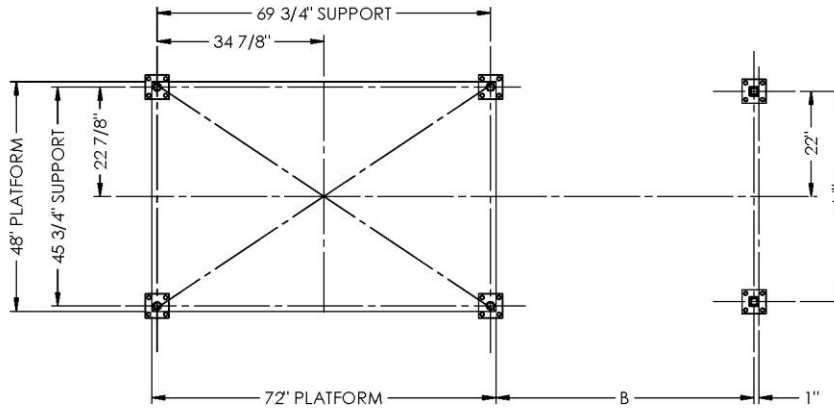

SECTION A-A

Dimensions:

A = (# of step X 7")

B = (# of step X 11")-1"

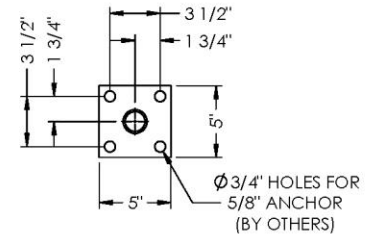

FOOT LAYOUT

SUPPORT ASSEMBLY INSTRUCTIONS

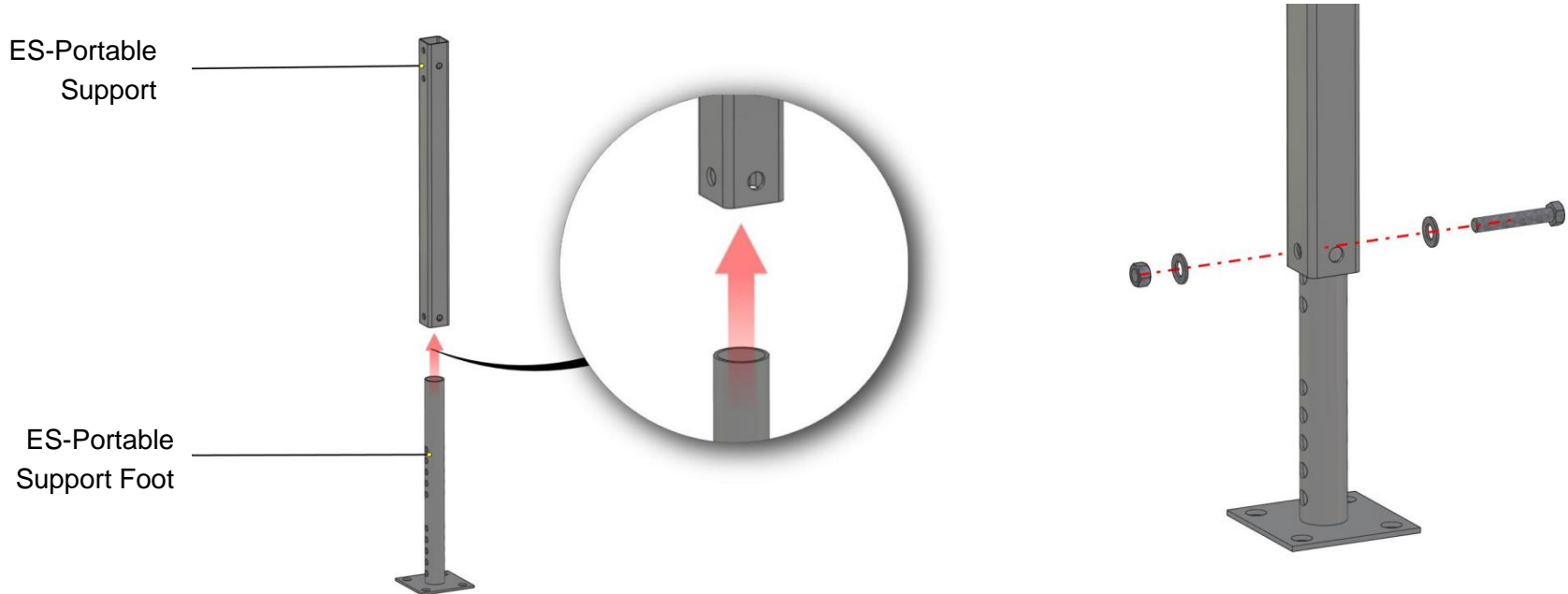

STEP 1: Orient components as shown.

NOTE: The support foot slides into the end of the support that has single holes only.

STEP 2: Attach hardware as shown and tighten hardware.

NOTE: Bolt head and nut should be on face of the support tube that has two bolt holes on the opposite end. See picture next page.

Support Foot has two sets of holes.

Middle hole of lower set is starting position for 28", 42", 56" heights.

Middle hole of upper set is starting position for 35", 49", 63" heights.

Adjust up or down as needed based on ground conditions.

SUPPORT TO PLATFORM INSTRUCTIONS

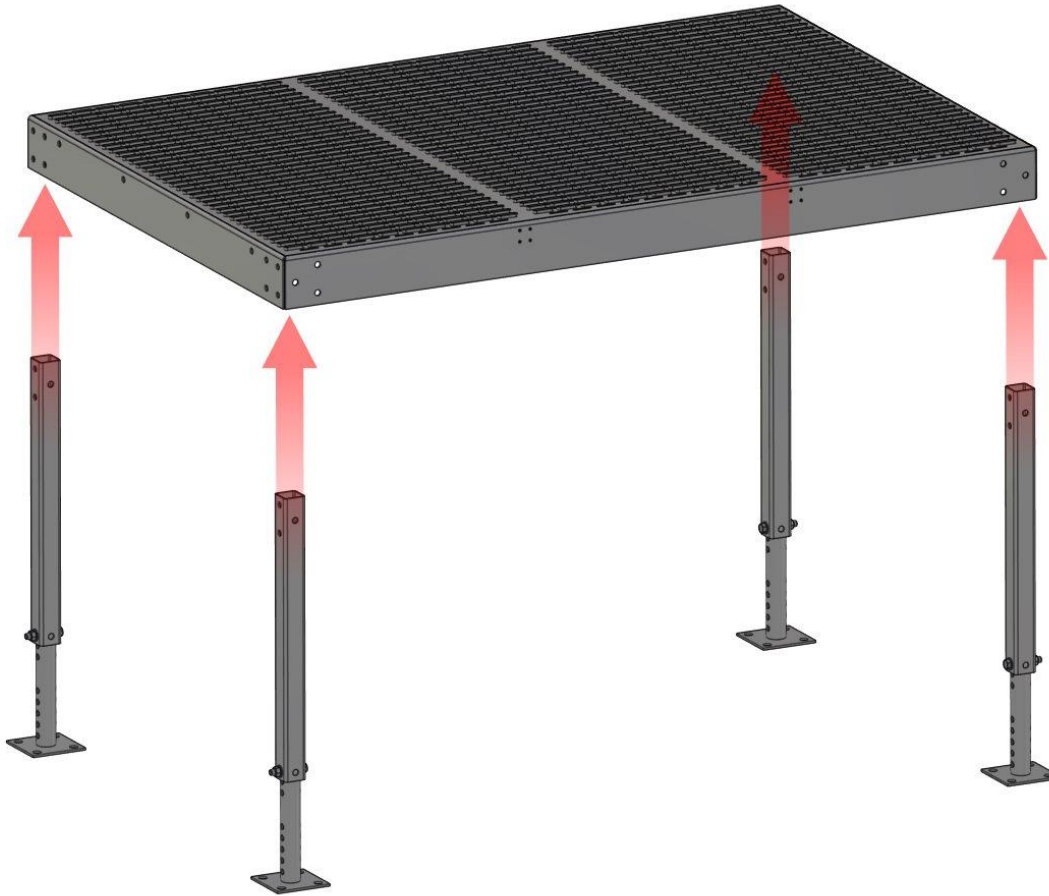

STEP 3: Orient components as shown.

NOTE: Support tubes should be oriented with two holes side facing 4 foot side of platform.

NOTE: If handrails will be used and configuration is know, referencing instruction for handrail attachment at this point could save a couple of steps.

SUPPORT TO PLATFORM INSTRUCTIONS

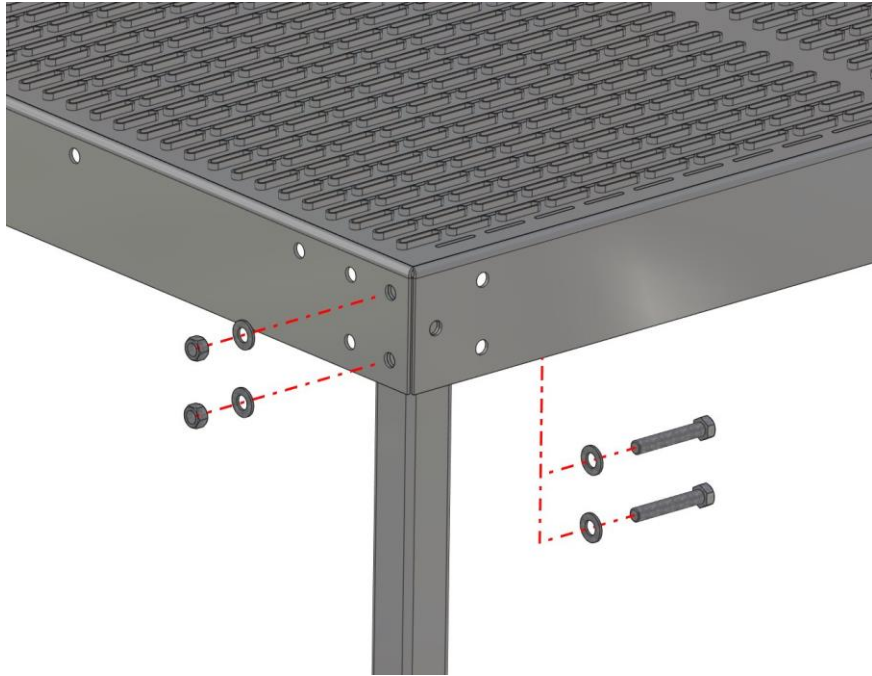

STEP 4: Attach hardware as shown and tighten hardware. There will be three bolts at each connection.

NOTE: Head of bolts should be on the inside of the platform.

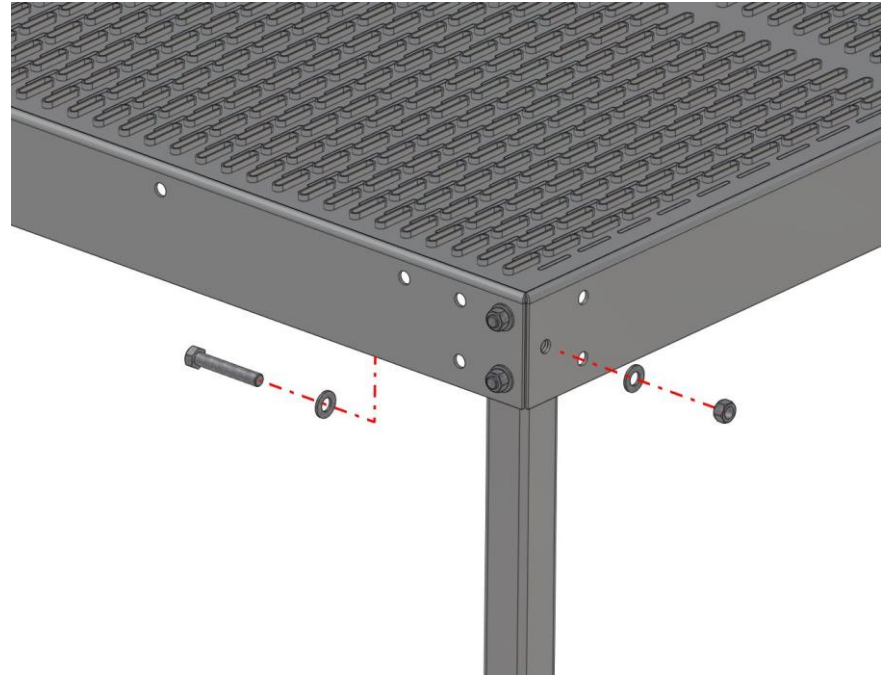

STEP 5: Repeat for steps 4 & 5 for all four supports.

SUPPORT ANGLE BRACES



Support Angle Braces
(Required for 56" and 63"
systems).

Attach angle braces as shown
as required using existing
support hardware.

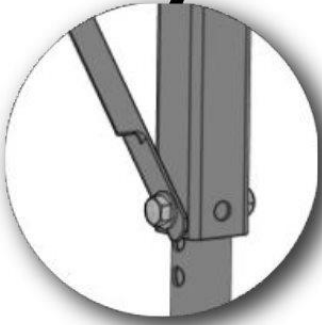

WARNING! Support angle
braces are required for 56" and
63" systems. Failure to use
support angle braces may cause
equipment to fail and may result
in death or serious personal
injury.

STAIR TO PLATFORM INSTRUCTIONS

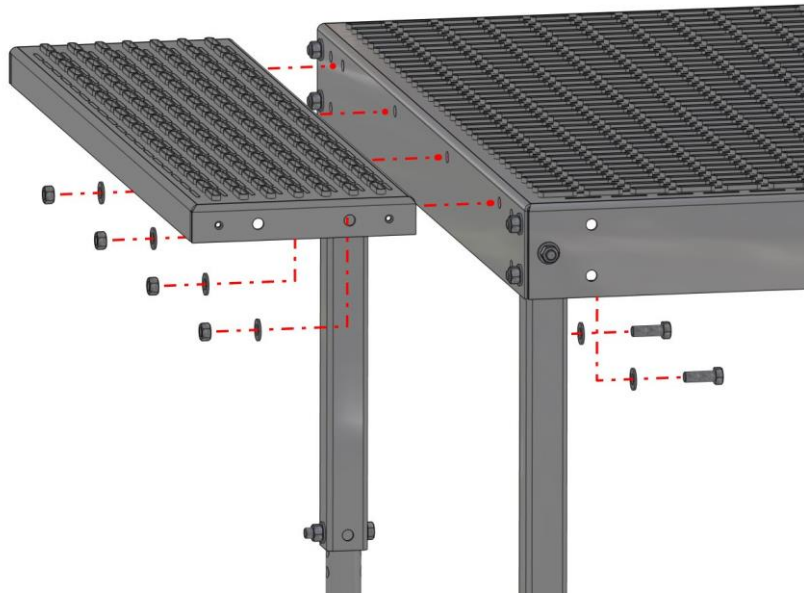

STEP 6: Orient step to platform as shown.

NOTE: Stairs only attach to 4 foot side of platform.



STEP 7: Attached hardware as shown and tighten hardware.

NOTE: This step will not use kick plate, but kick plates are to be used on all other steps (see Sheet 17).

STAIR STEP KICK PLATE INSTRUCTIONS

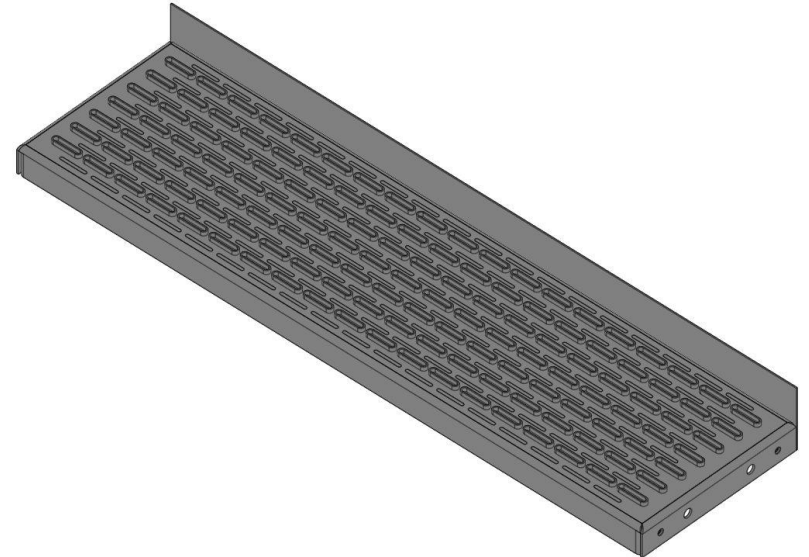
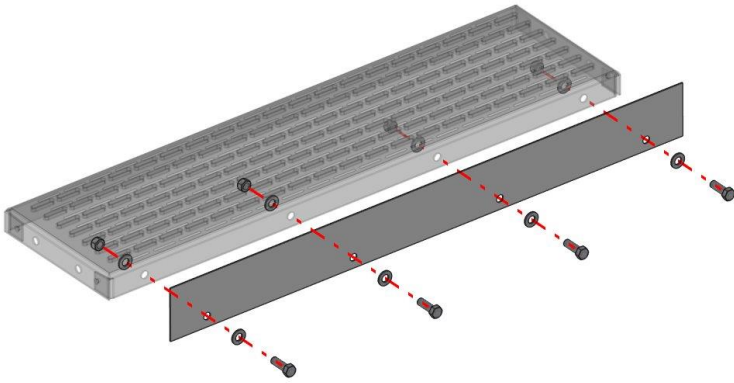

STEP 8: Orient step kick plate to step as shown.

STEP 9: Attached hardware as shown and tighten hardware.
Repeat for all remaining steps.

NOTE: Top step of stairs will not use kick plate.

STAIR STRINGER INSTRUCTIONS

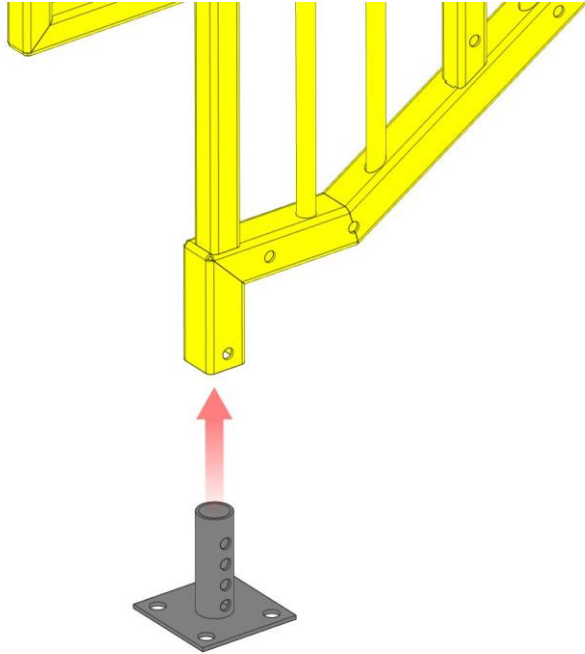

STEP 10: Slide stair foot into stair stringers as shown.

STEP 11: Attached hardware as shown and tighten hardware.

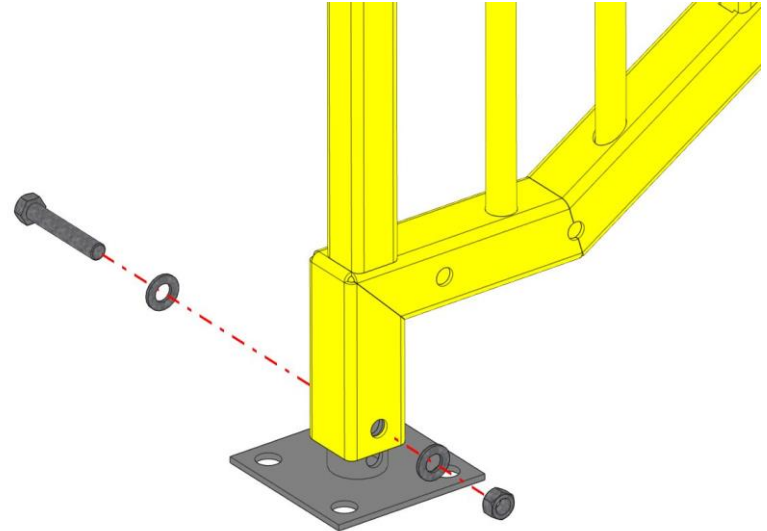

Stair Foot has four holes.
Second hole from the base plate is starting position.
Adjust up or down as needed based on ground conditions.

STAIR STRINGER INSTRUCTIONS

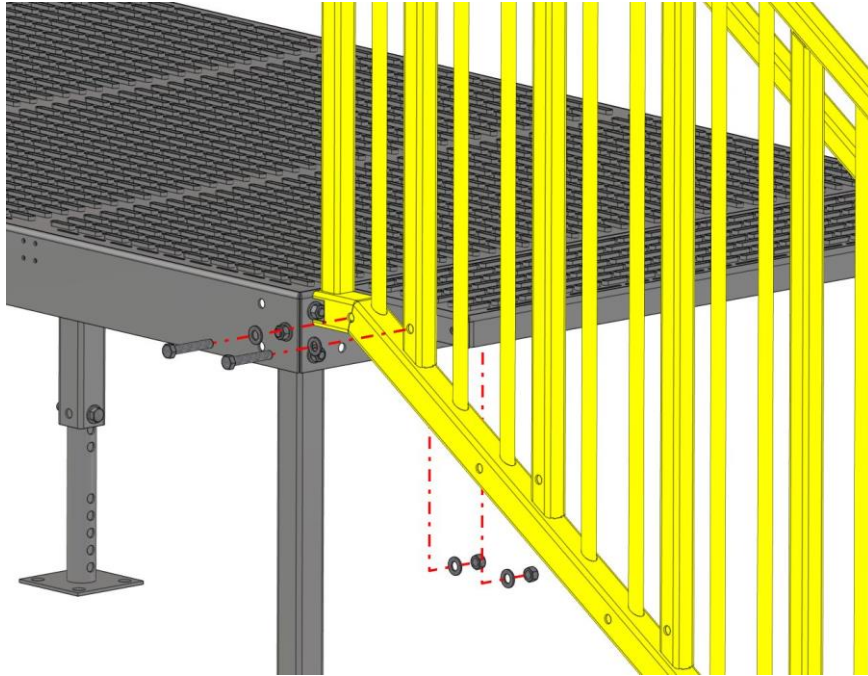

STEP 12: Position stringer next to upper step as shown.

NOTE: Stringer grab rail should be oriented towards step.

STEP 13: Attached hardware with head of bolt oriented to the outside of the stringer. Start nut on bolt, but leave loose.

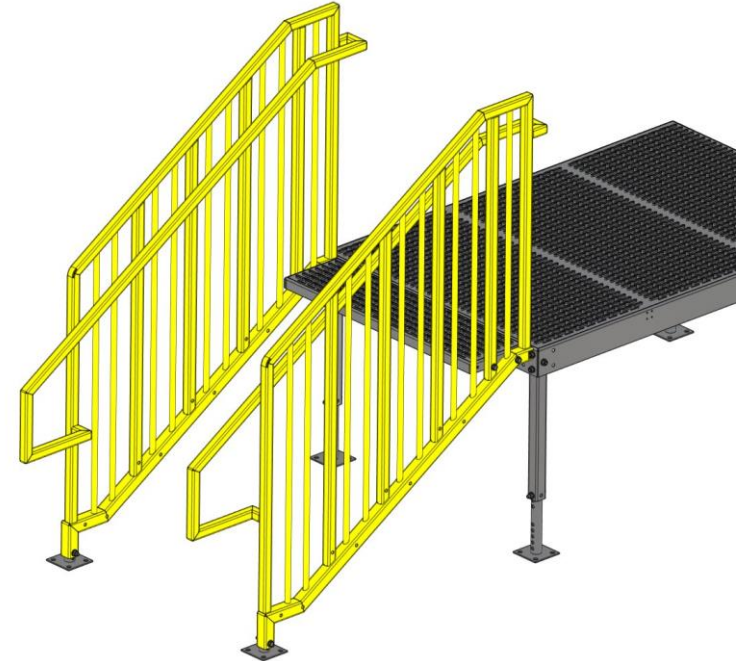

Repeat Steps 12 and 13 for each stringer.

STAIR STRINGER INSTRUCTIONS

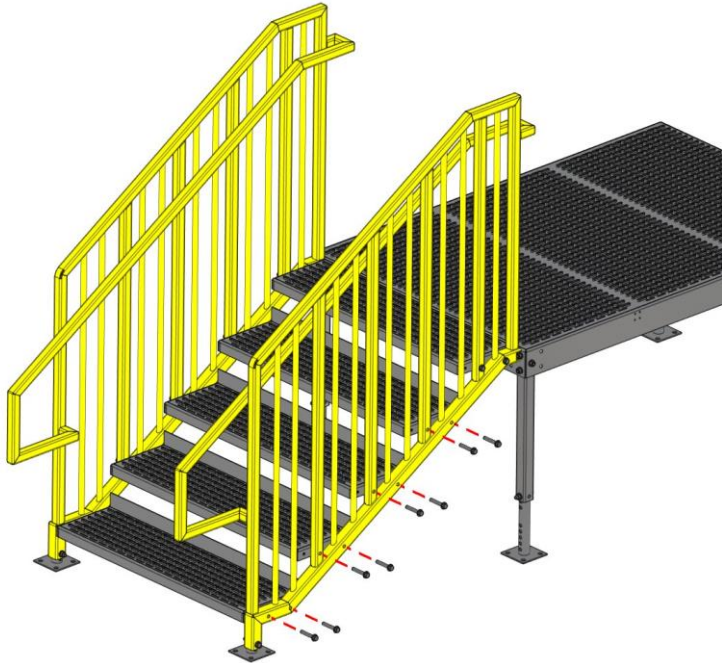

STEP 14: Position all other steps with attached kick plates to stringer as shown.

STEP 15: Attach hardware with head of bolt oriented to the outside of the stringer. Start nut on bolt, but leave loose.



STEP 16: Once all steps are located between stringers, securely tighten all steps to stringer hardware.

HANDRAIL MOUNT ANGLES INSTRUCTIONS

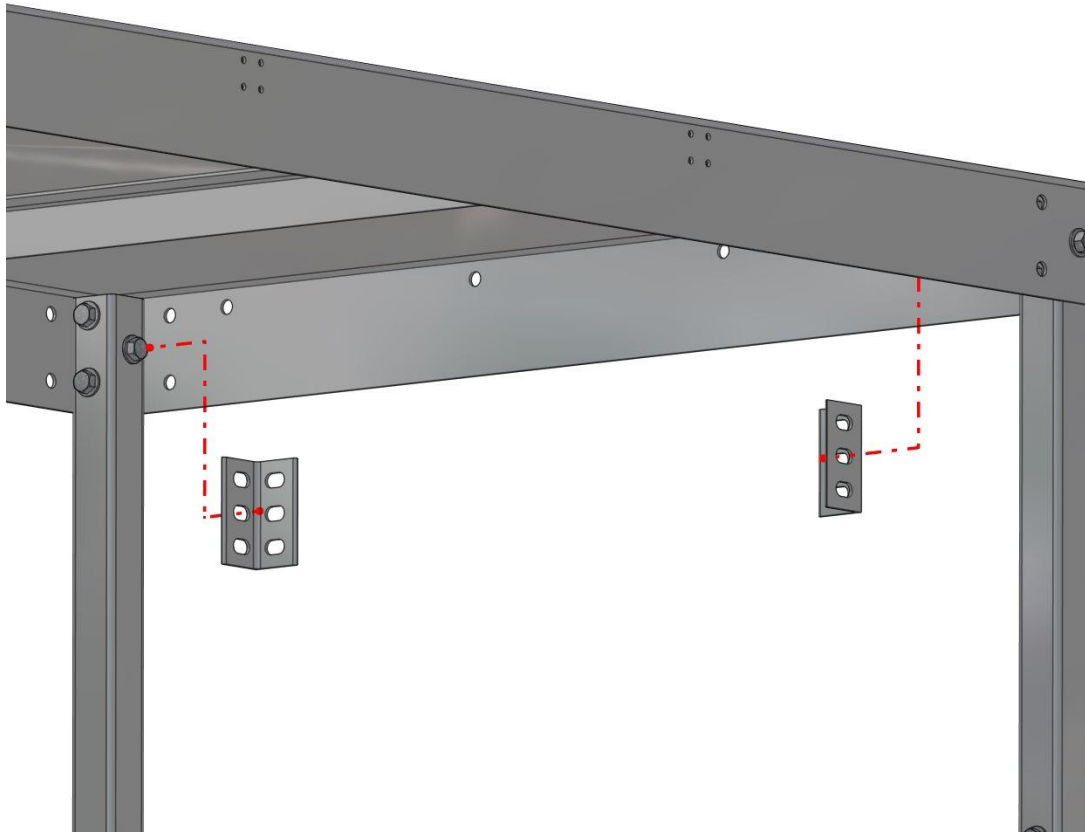

STEP 17: Attach the handrail mount angles to the support tubes. Orient one leg against the support tube and the other against the inside wall of the platform to which the handrail is to be attached.

NOTE: Use the bolts that connect the support to the platform.



WARNING! Handrail Mount Angle must be used at this connection. Failure to use Handrail Mount Angle may cause equipment to fail and may result in death or serious personal injury.

HANDRAIL INSTRUCTIONS

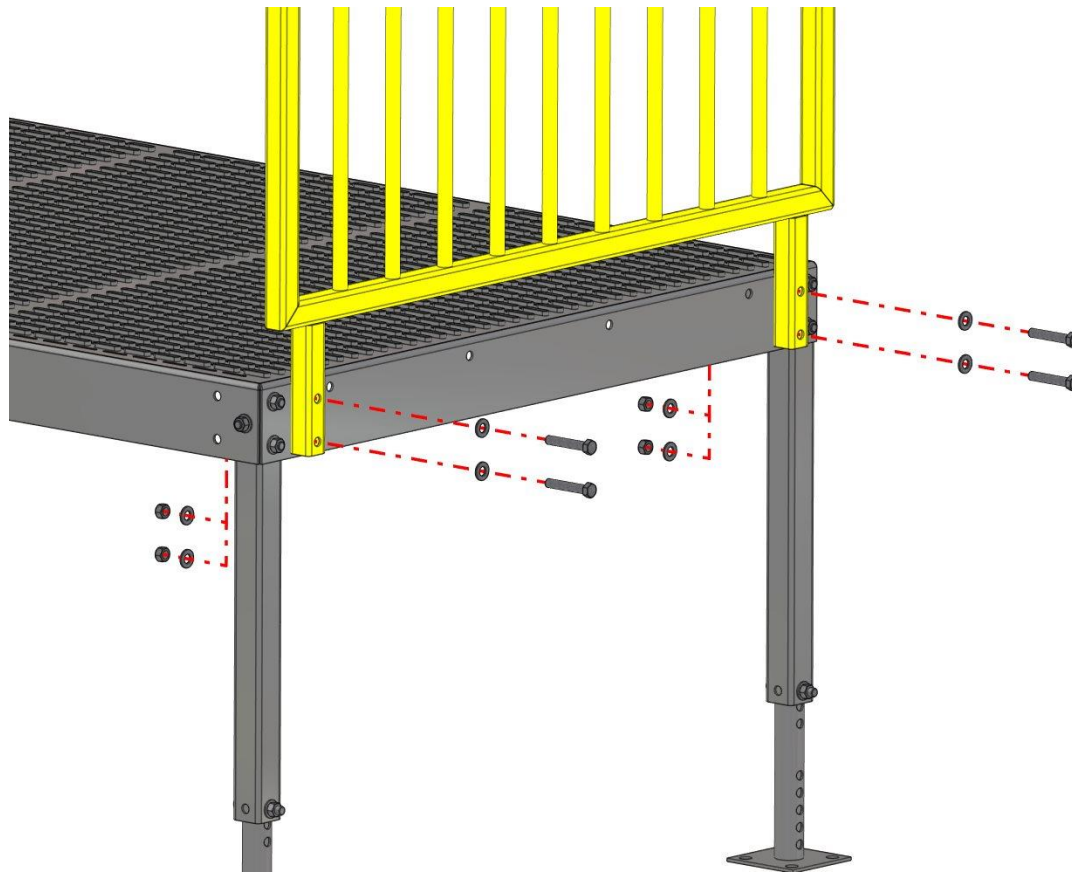

STEP 18: Position handrail and attach hardware as shown. Tighten hardware.

NOTE: Bolts connecting handrail to platform must go through handrail, platform wall and handrail mount angle.



WARNING! Handrail Mount Angle must be used to attach a handrail to a platform. Failure to use Handrail Mount Angle may cause equipment to fail and may result in death or serious personal injury.

IBC COMPLIANCES

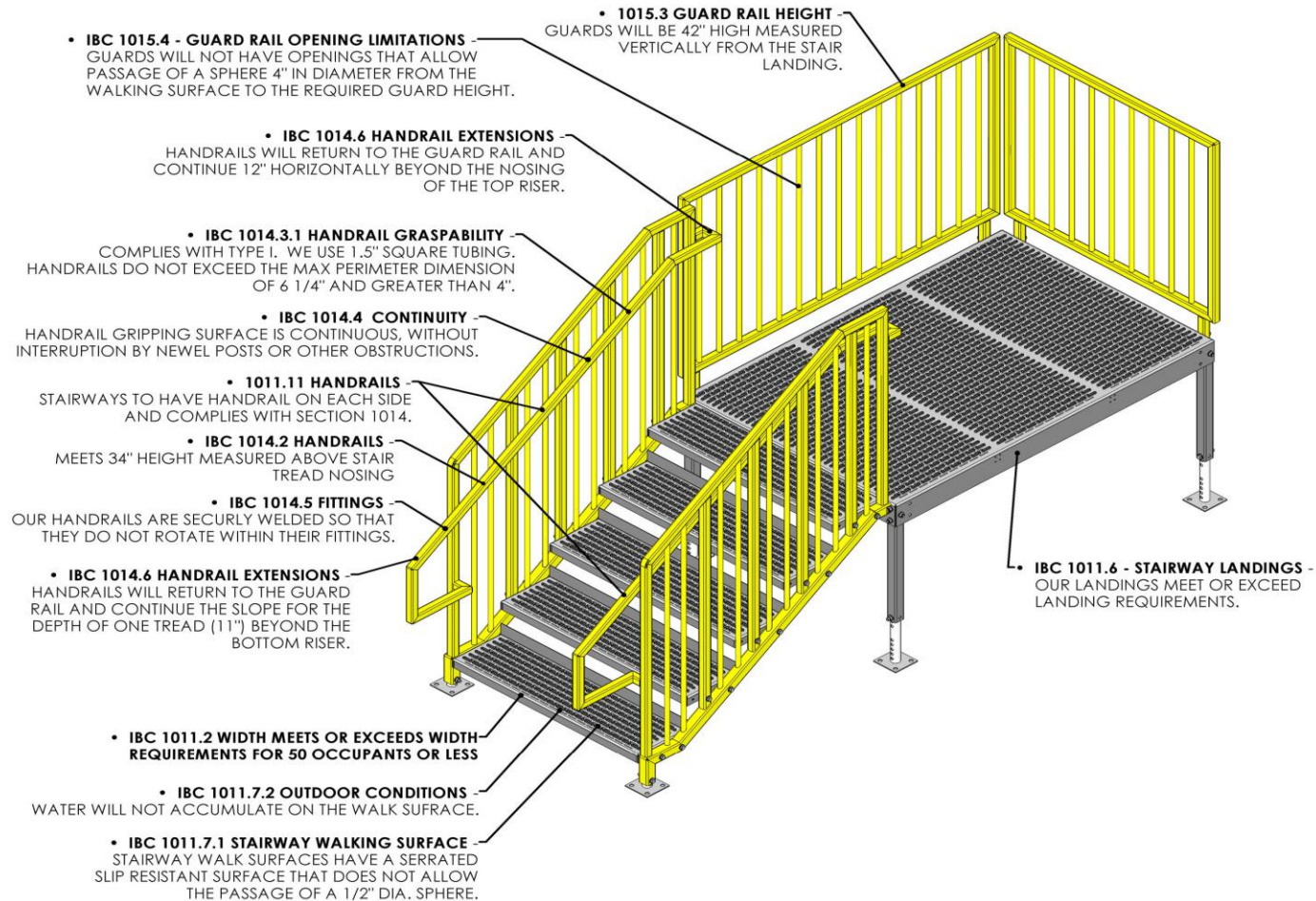

IBC COMPLIANCES

