



E ERECTA STEP
Commercial Stair Series

OWNER'S MANUAL
Commercial Stair Series



THIS PRODUCT AND/OR IT'S COMPONENTS MAY BE COVERED BY ONE OR MORE PATENTS, SEE WWW.SAFERACK.COM/PATENTS

COMMERCIAL PLATFORM SYSTEM



WARNING! READ CAREFULLY AND UNDERSTAND ALL INSTRUCTIONS BEFORE STARTING INSTALLATION. FAILURE TO FOLLOW ALL INSTRUCTIONS MAY RESULT IN DEATH OR SERIOUS PERSONAL INJURY.

IMPORTANT

- Equipment should not be altered or modified from its original design without consultation with the manufacturer.
- Equipment which is damaged or becomes damaged during use, handling, or shipping should be set aside and not used.



- **WARNING! Failure to anchor unit properly with the correct layout dimensions can result in product damage not covered under warranty. Failure to secure all fasteners may result in death or serious personal injury.**
- Do not assemble unit off of anchor bolts and then lift onto them. System should only be assembled in its final location. Never move an assembled system.
- All bolts to be tightened per AISC.



- **WARNING! After a usage period of 60-90 days, check all fasteners to ensure connections are secure. Periodic inspection is recommended to insure all fasteners are secured. Failure to secure all fasteners may result in death or serious personal injury.**



- **WARNING! This product can expose you to chemicals including cadmium, which is known to the State of California to cause cancer, and/or birth defect or other reproductive harm.**
For more information, go to www.P65warnings.ca.gov

COMMERCIAL PLATFORM SYSTEM

ASSEMBLY CRITERIA

Verify proper installation according to ErectASStep – Commercial Series installation manual. In addition, make sure to check the following specifically.

- Ensure all anchor bolts are installed properly at the stair base and supports.
- Ensure supports are vertically plumb.
- Ensure platform and steps are level.
- Ensure all bolts are properly tightened according to ErectASStep – Commercial Series installation manual.

COMMERCIAL SERIES PLATFORM SYSTEM



Thank you for purchasing an ErectAStep Commercial Series Metal Stair Unit!

Your new ErectAStep stair unit has been manufactured using the latest in robotic and laser technologies, along with only the highest quality materials to ensure dependable service for years to come.

Please take care, to follow all installation instructions to ensure your new Commercial Metal Stair performs at it's best. Please note: design limitation can exist with respect to required supports, adequate footings, and the prescribed application. Please seek the help of licensed professional engineer if further support and/or foundation requirements are in question.

For further questions or concerns, please contact Customer Support at [888.878.1839](tel:888.878.1839)

Thanks again for choosing ErectAStep!

COMPONENTS



PLATFORM



4FT HANDRAIL



6FT HANDRAIL



STAIR UNIT

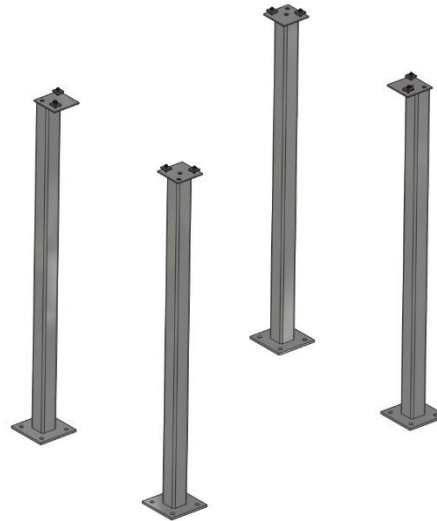

SUPPORTS

- Forklifts or other equipment may be required for assembly.

SUPPORT INSTRUCTIONS

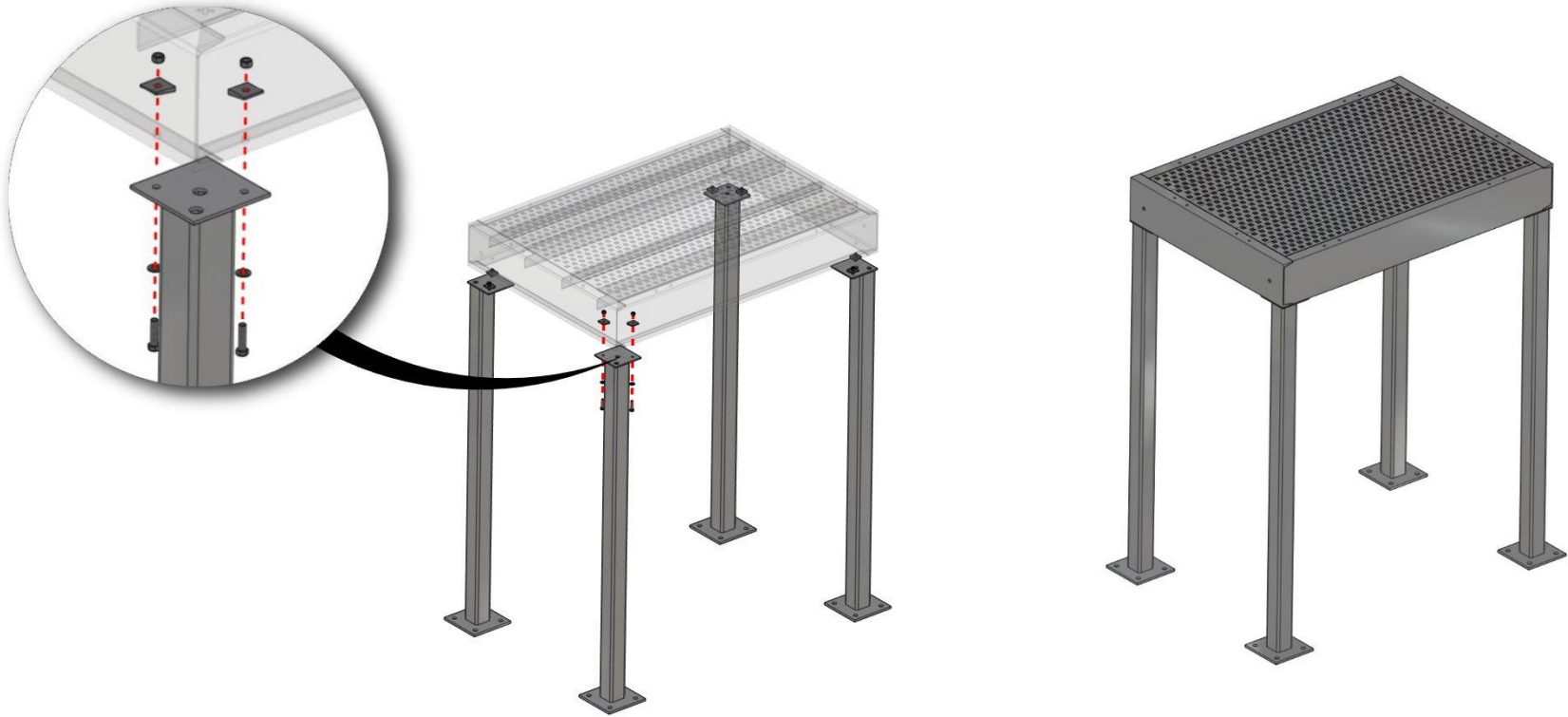

- Supports should be oriented and positioned based on anchor layout.
- See approval drawings for anchor layouts.
- Orient supports in line with outer edges of platform. Note that support tube should be directly under channel of platform.
- Use $\frac{1}{2}$ " x $2 \frac{1}{4}$ " bolt, nut, flat washer and bevel washer as shown.



WARNING! Failure to properly attach supports to platform may cause equipment to fail and may result in death or serious personal injury.

STAIR UNIT INSTRUCTIONS

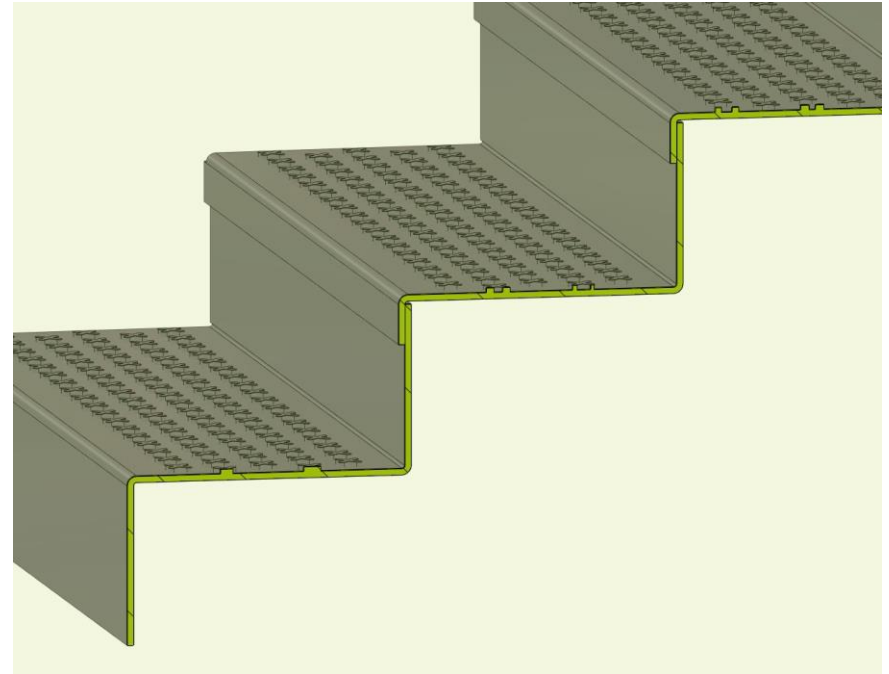
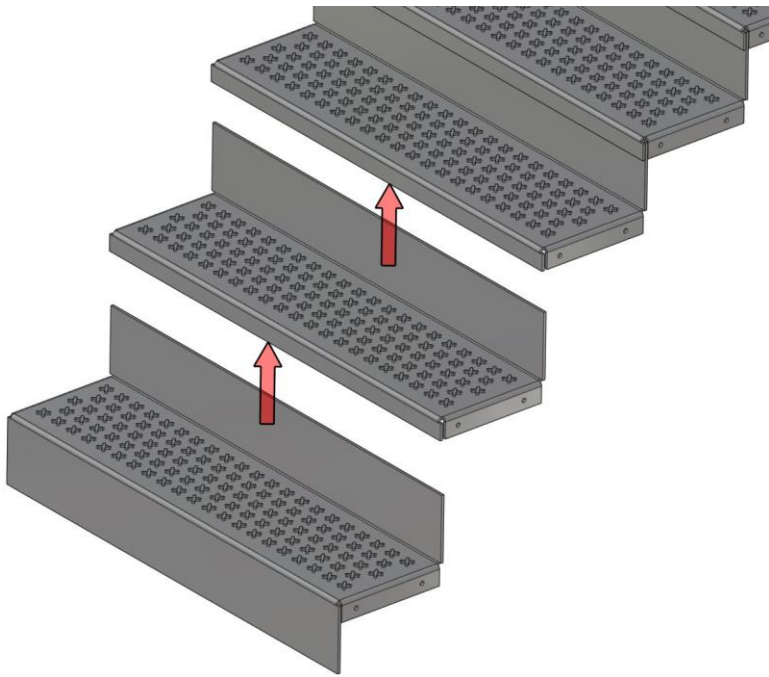

- Stair steps should be oriented with vertical kick plate behind short vertical leg of next step.
- Bottom step has both leading edge and trailing edge kick plate. One per unit
- Intermediate steps have only trailing edge kick plate.
- Top step does not have kick plate. One per unit.

NOTE: Some components of stair unit will be shipped already assembled.

STAIR UNIT INSTRUCTIONS

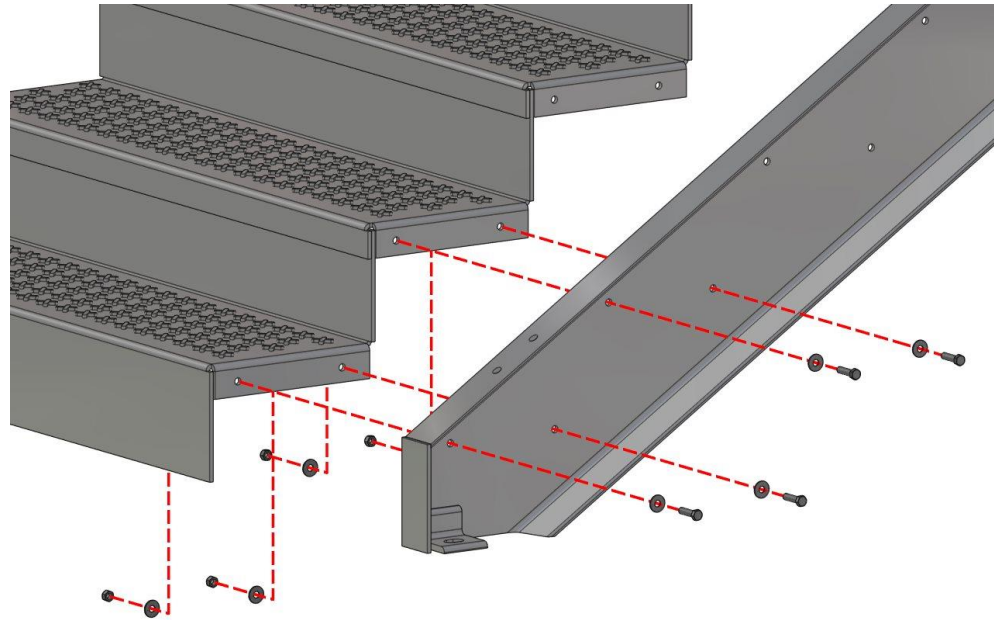

- Use 3/8" x 1 1/2" bolts, nuts and flat washers (each side) as shown to connect left and right side stringers to steps.
- Securely tighten all hardware once all steps and stair unit has been leveled.

 **WARNING!** Failure to properly attach stair steps may cause equipment to fail and may result in death or serious personal injury.

NOTE: Some components of stair unit will be shipped already assembled.

STAIR UNIT INSTRUCTIONS

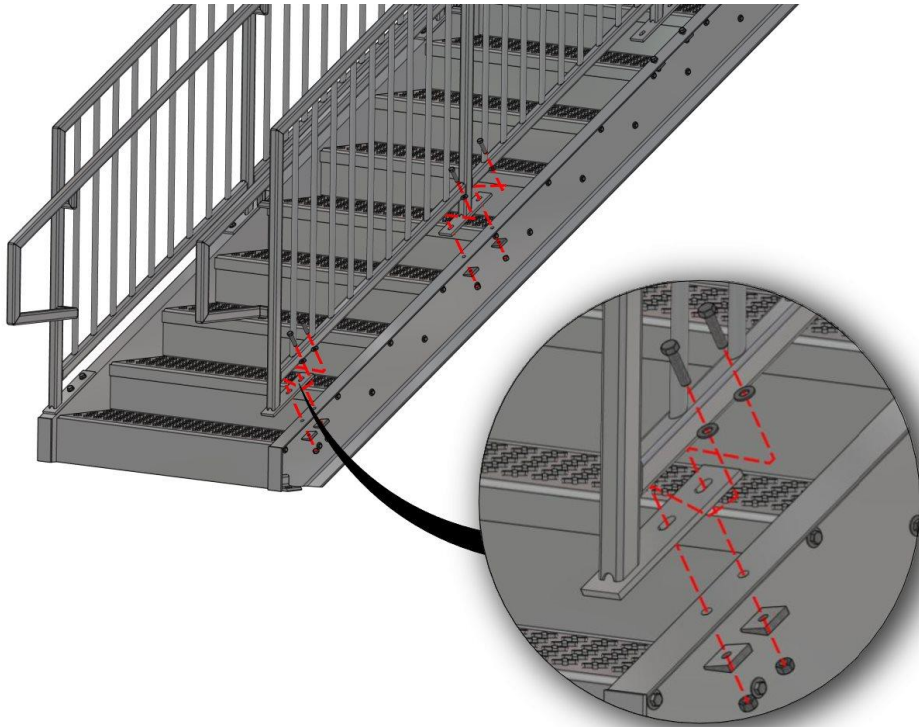

- Use 1/2" x 2" bolts, nuts, flat washers and bevel washers as shown to connect stair handrails to stringers.
- Securely tighten all hardware once all steps and stair unit has been leveled.

 **WARNING!** Failure to properly attach stair handrails may cause equipment to fail and may result in death or serious personal injury.

NOTE: Some components of stair unit will be shipped already assembled.

STAIR UNIT TO PLATFORM INSTRUCTIONS

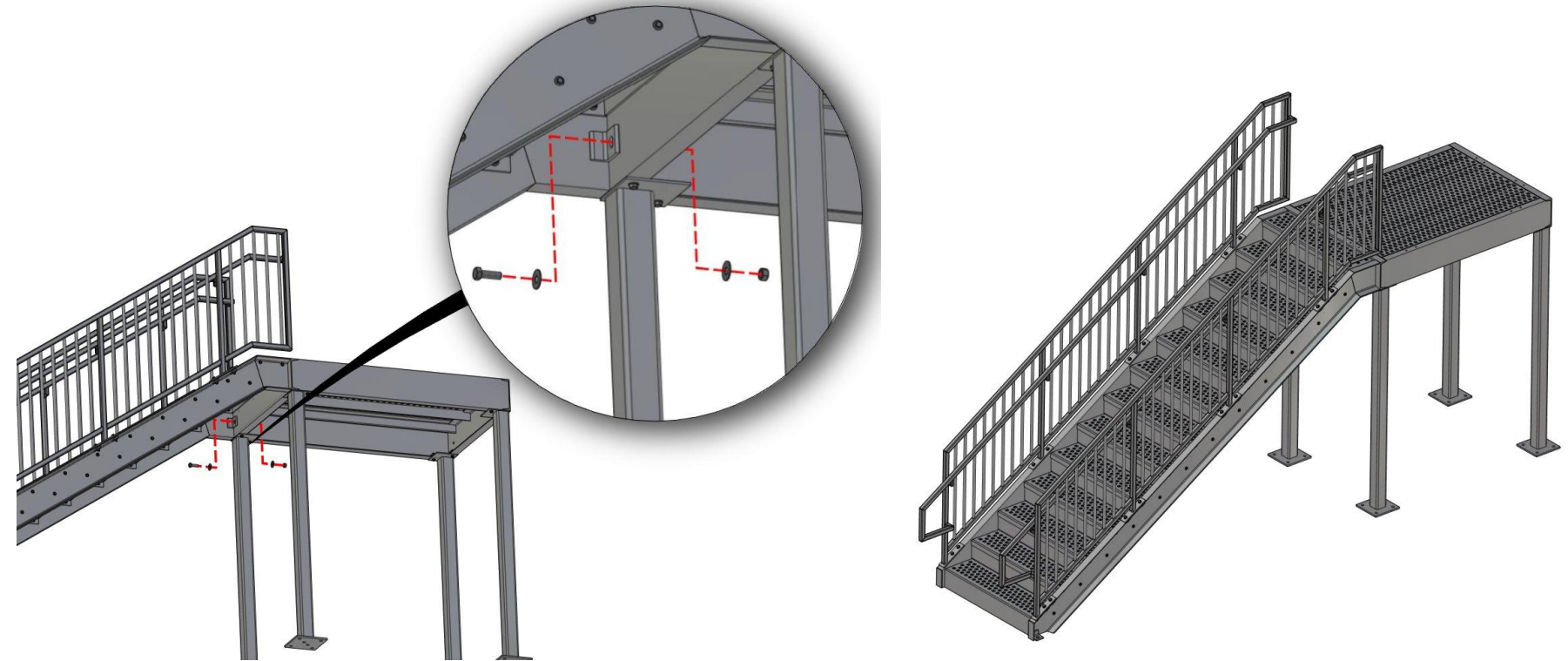

- Use 3/4" x 2 1/4" bolts, nuts and flat washers as shown to connect stair unit to the platform.
- Securely tighten all hardware once unit has been leveled.

 **WARNING!** Failure to properly attach stair unit to platform may cause equipment to fail and may result in death or serious personal injury.

HANDRAIL TO PLATFORM INSTRUCTIONS

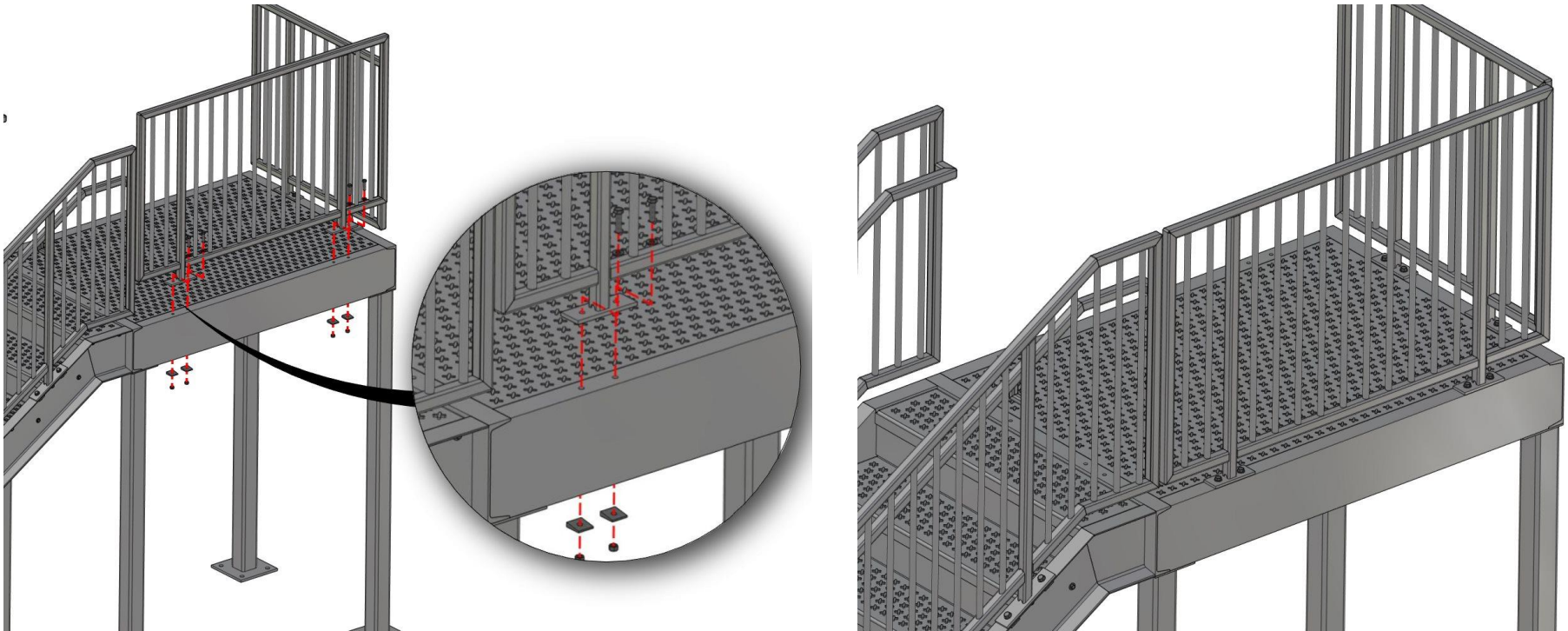

- Use ½" x 2" bolts, nuts, flat washers and bevel washers as shown to connect handrails to the platform.
- Securely tighten all hardware.

 **WARNING!** Failure to properly attach handrails may cause equipment to fail and may result in death or serious personal injury.

NOTE: Narrow handrails go on narrow side of platform. Wide handrails go on wide side of platform. See approval drawings for handrail orientation.

IBC COMPLIANCES

