

SERIES NAME	A	B
RS-MP-SERIES-MP27	27" (686 mm)	10'-4 3/8" (3159 mm)
RS-MP-SERIES-MP36	36" (914 mm)	11'-1 3/8" (3388 mm)
RS-MP-SERIES-MP45	45" (1143 mm)	11'-10 3/8" (3616 mm)
RS-MP-SERIES-MP54	54" (1372 mm)	12'-7 3/8" (3845 mm)
RS-MP-SERIES-MP63	63" (1600 mm)	13'-4 3/8" (4074 mm)
RS-MP-SERIES-MP72	72" (1829 mm)	14'-1 3/8" (4302 mm)

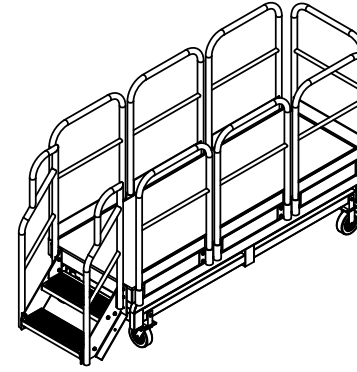

RS-MP-SERIES-MP27

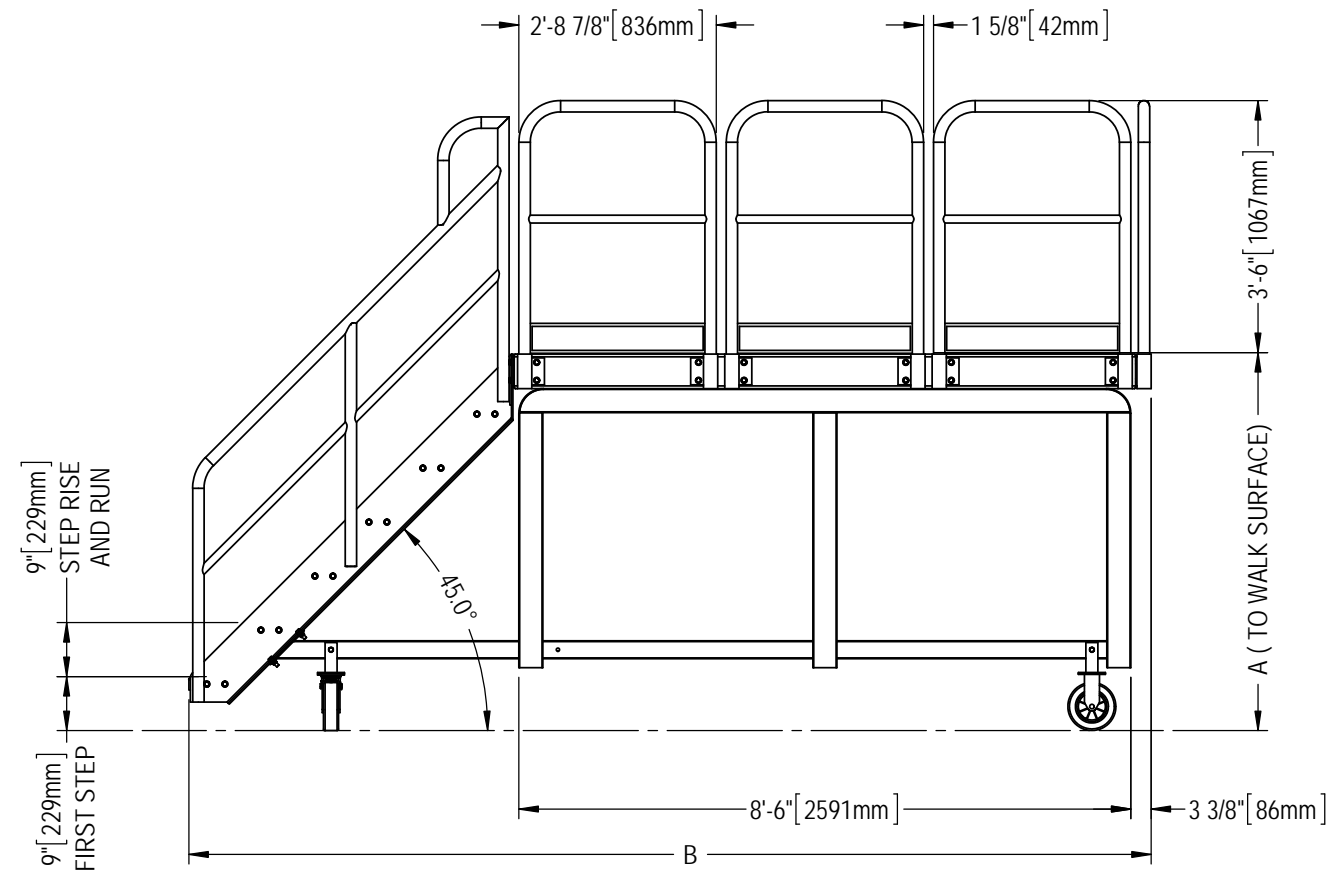
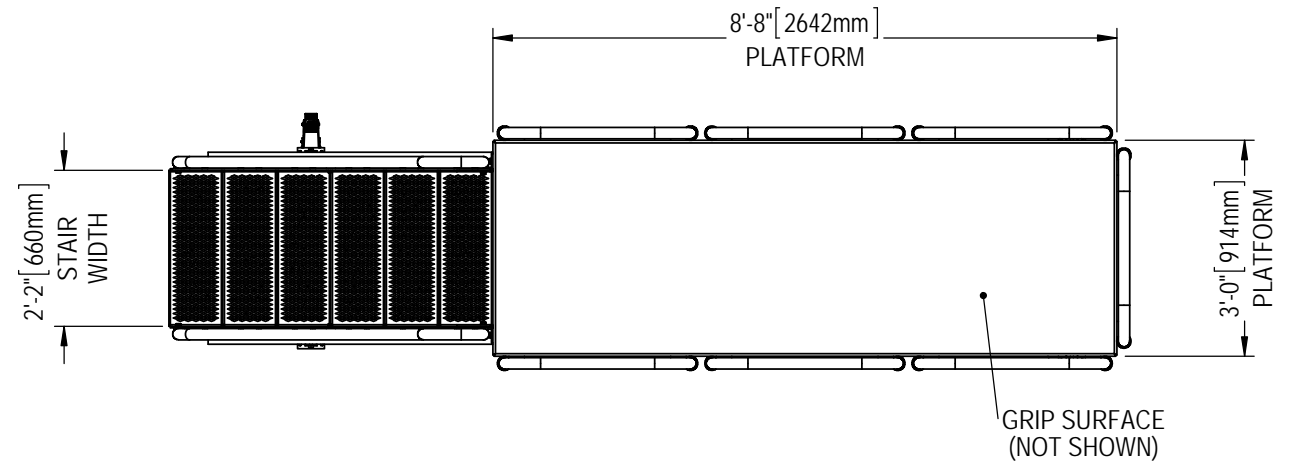
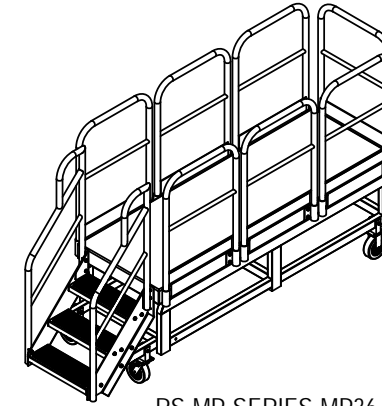

RS-MP-SERIES-MP36

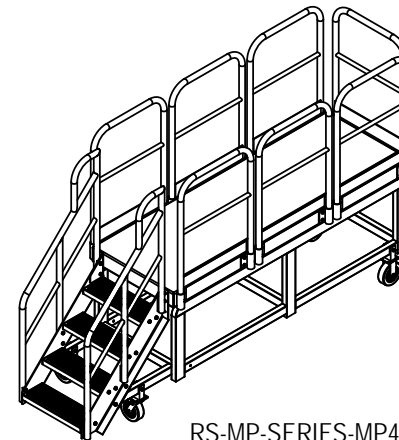

RS-MP-SERIES-MP45

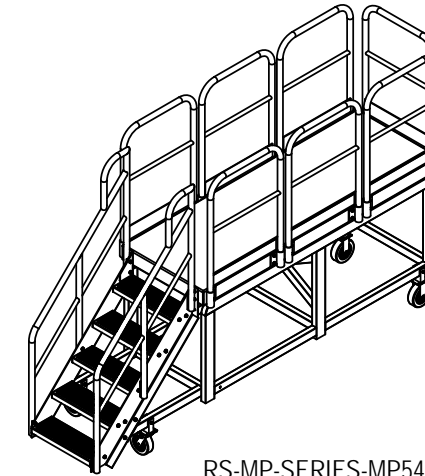

RS-MP-SERIES-MP54

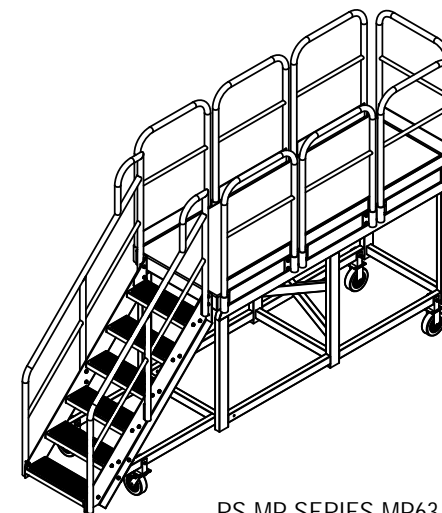

RS-MP-SERIES-MP63

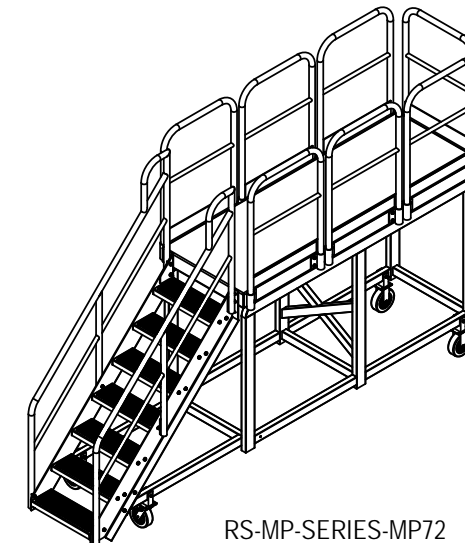

RS-MP-SERIES-MP72

ALL INFORMATION CONTAINED HEREIN IS CONFIDENTIAL & PROPRIETARY. IT MAY NOT BE DISCLOSED IN ANY FORM WITHOUT THE WRITTEN CONSENT OF ROLLASTEP.		PART NAME: RS-MP SERIES SPEC SHEET MODEL BY: TK DRAWN BY: TK CHECKED BY: TK PROGRAMMED BY: TK PROGRAMMED CHECKED BY:	DATE: 8/28/11 DATE: 8/28/11 DATE: 8/28/11 DATE: 8/28/11 DATE: 8/28/11 DATE:	FINISH: 1:32 SHEET SCALE: 1 SHEET: 1
<h1>ROLLASTEP</h1>		CUSTOMER	JOB #	ABAS #
		RS-MP SERIES SPEC SHEET		
ROLLASTEP WELDING STANDARDS SEAL WELD UNLESS OTHERWISE NOTED USE FILLETS LISTED BELOW UNLESS OTHERWISE NOTED		Material Thickness of Thicker Part (mm) Material Thickness of Thinner Part (mm) Minimum Fillet Size - S (inch) Minimum Fillet Size - S (mm)	1/4" (6) to 1/2" (13) 1/4" (6) to 1/2" (13) 3/16" (5) 3/16" (5) 1/2" (13) to 3/4" (19) 1/2" (13) to 3/4" (19) 1/4" (6) 1/4" (6) Over 3/4" (19) Over 3/4" (19) 5/16" (8) 5/16" (8)	
BATCH	DATE	REV	DESCRIPTION	BY
2	3/8/12	2	UPDATED WELD SPECS FOR ENGLISH/METRIC DIMENSIONS	TK
1	2/24/12	1	SPEC SHEET CREATED (ENGLISH/METRIC)	TK