

Railway Carriage

Product Overview

The Railway Carriage has been developed to act as an ideas hub for collaboration as well as a relaxed, focus space for concentration, this office meeting booth has a sleeker aesthetic with a stronger, more modular design. Available in over multiple combinations, it has varying styles, a huge range of finish options and accessories. Not only can this pod create an extension of your brand in the workspace with its customizable components, it is also relocatable and therefore adaptable to ever-changing workspace requirements. Attract top talent by creating an efficient, uniquely-designed space with the Railway Carriage.

Dimensions

See the full dimension drawings located at the end of this document.

Environmental Summary

Furniture grade HPL or lacquered ply cladding panels are fixed to the external face of the main steel structure. Upholstered acoustic panels are clipped to the interior surface. Built in upholstered seating and a table complete the booth.

Environmental Document & Declare Label



Sustainability Compliance

Spacestor products can support leading sustainability standards including WELL, LEED, BREEAM, LBC (Living Building Challenge), and SKA. By aligning with these frameworks, we help you create environmentally responsible spaces that enhance employee wellbeing.

We simplify the complexity of certification by providing clear, tailored guidance and product-specific compliance breakdowns for your project.

Scan above for more information or contact your dedicated rep for detailed documentation.

Electrics

Lighting

Low Voltage LED Lighting for consistent illumination is supplied on a PIR system with movement sensor.

Options include:

- Pendant Light
- Striplight
- Spotlights

Power

Upholstered Back variations have 2 x Regional Power, 1 x Twin USB (USB-A & USB-C)

Open Back variations, power can either be placed in the front of the seat or the end of the seat and consists of 2 x Regional Power, 2 x Twin USB (USB-A & USB-C)

Our Railway Carriage units use 120v power with 72" lead and soft wire standard Nema 15a plug which exits booth at back RH corner. Power can exit at other locations or roof if needed and agreed with the project team at time of order.

Unit draws 10amp at max load,

Up to 2 units can be daisy chained together into one power outlet.

Hardwire option is available to meet Chicago code Title 14E

Safety

Sprinklers

To address the need for any required fire sprinkler regulations, this product can accept a sprinkler head drop from the building fire sprinkler system via a 2½" dia hole, managed per project with the Project Manager. A flexible fire sprinkler drop is recommended.

Full dimension drawings at the end of the document.

Fire Ratings

- All fabrics specified by Spacestor comply with California Technical Bulletin 117 for smolder resistance.
- All Foam used in our products also complies with California Technical Bulletin 117
- All products have a label fitted as below

General safety

- All maintenance and repair tasks must be performed by appropriately qualified and authorised technicians.
- Only use tools that are appropriate for these tasks.

Weights

2 Person Open Back Flat Roof with Spotlight: 584 lbs

4 Person Open Back Flat Roof with Spotlight: 794 lbs

2 Person Upholstered Back Flat Roof with Spotlight: 765 lbs

4 Person Upholstered Back Flat Roof with Spotlight: 917 lbs

2 Person Banquette: 463 lbs

4 Person Banquette: 556 lbs

Structural

Adjustable levelers on the product have up to ¾" / 20mm tolerance.

Seismic

To address the need for any required seismic regulations, this product can be fitted with brackets, managed per project with the Project Manager.

Shipping

Shipping dims/weight/packaging are dependent per project - please enquire. Aprox. 1 x double pallet and 1 x single pallet.

Aprox. weight for Railway Carriage Pitched Roof:

Pallet no.	Length (in)	Width (in)	Height (in)	Weight (lbs)
1	78¾"	43¼"	19¾"	507
2	47¼"	39⅜"	63"	287

TECHNICAL DATA

Railway Carriage

Dimensions

2 Person, Arch Roof, Upholstered Back, with Pendant

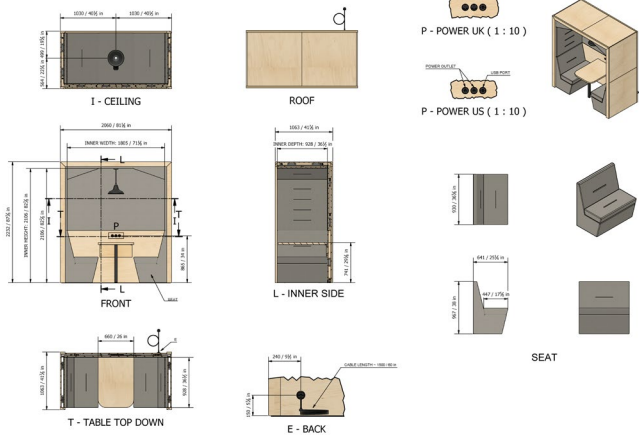

2 Person, Flat Roof, Upholstered Back, with Pendant

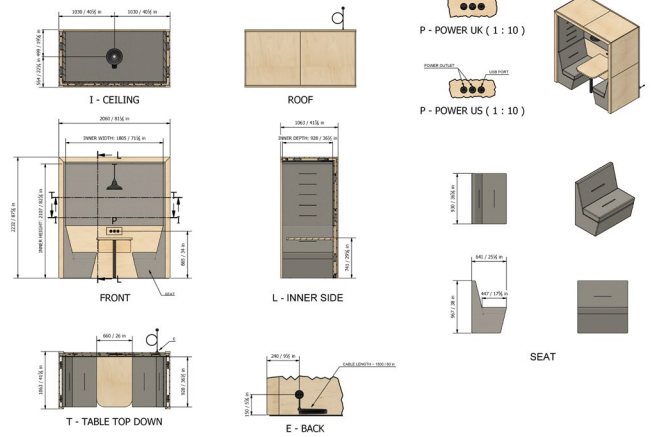

2 Person, Arch Roof, Upholstered Back, with Spotlight

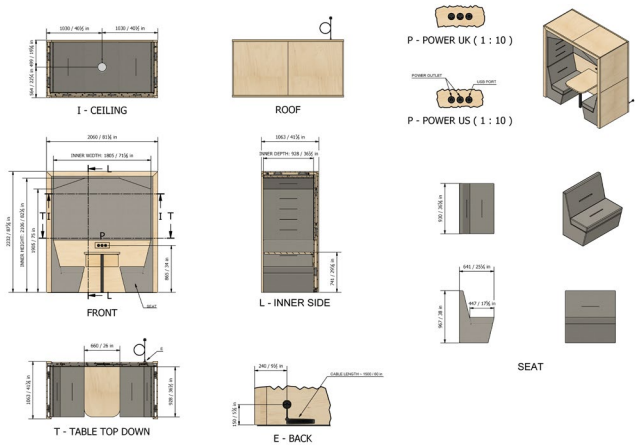

2 Person, Flat Roof, Upholstered Back, with Spotlight

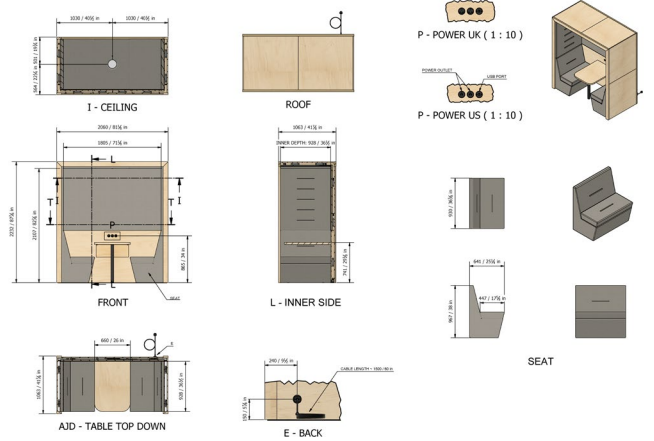

2 Person, Arch Roof, Upholstered Back, with Striplight

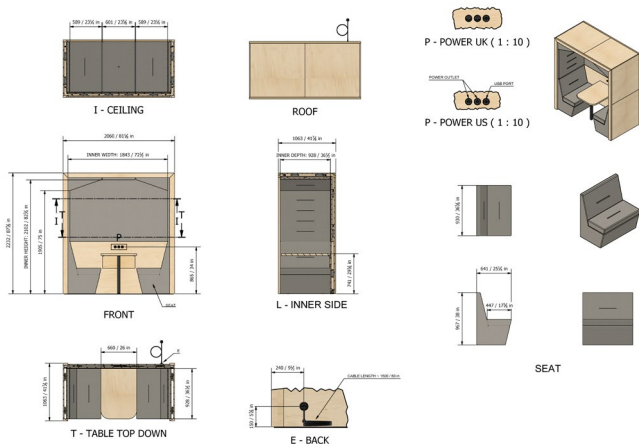

2 Person, Flat Roof, Upholstered Back, with Striplight

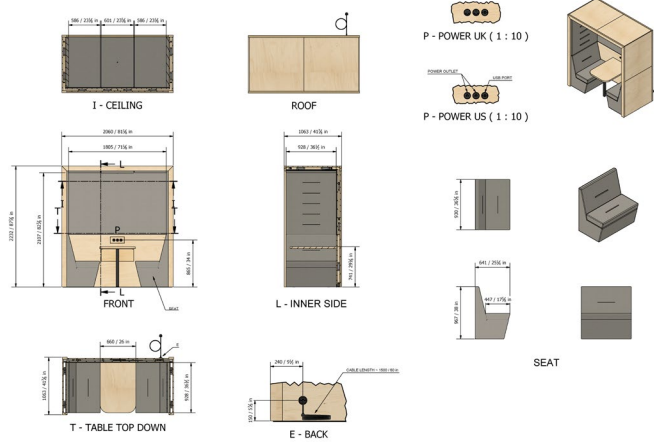

TECHNICAL DATA

Railway Carriage

R4 Person, Arch Roof, Upholstered Back, with Pendant

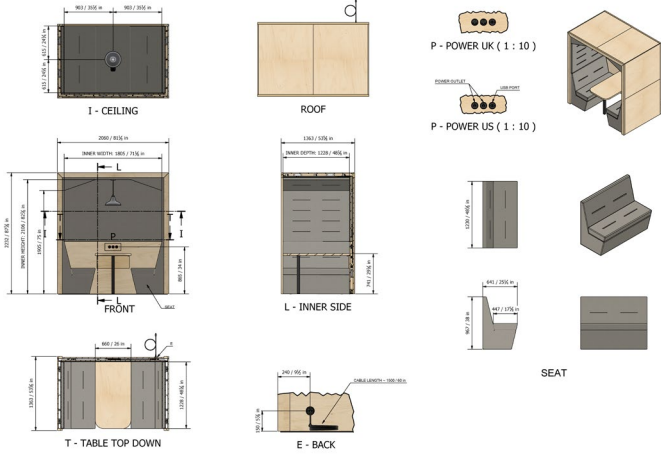

4 Person, Flat Roof, Upholstered Back, with Pendant

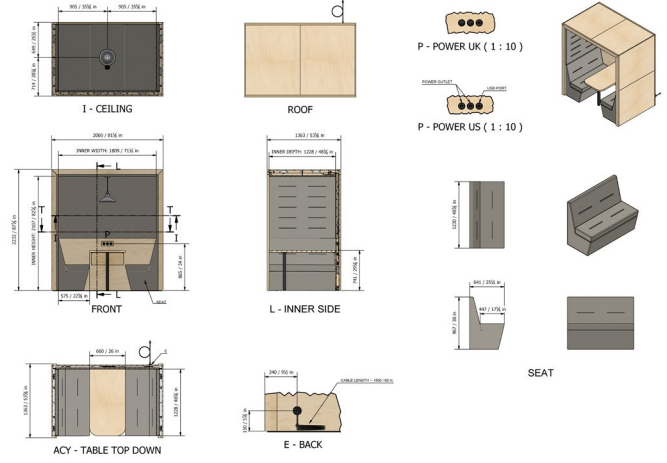

4 Person, Arch Roof, Upholstered Back, with Spotlights

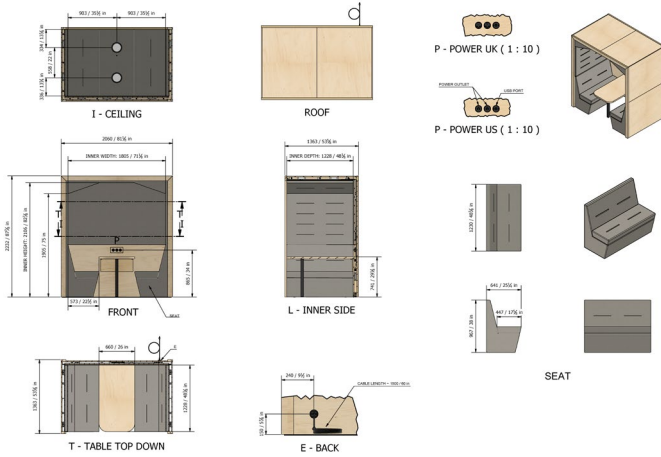

4 Person, Flat Roof, Upholstered Back, with Spotlights

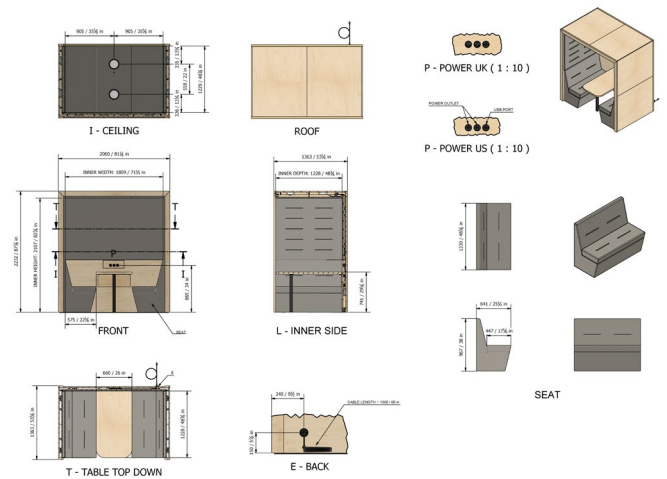

4 Person, Arch Roof, Upholstered Back, with Striplight

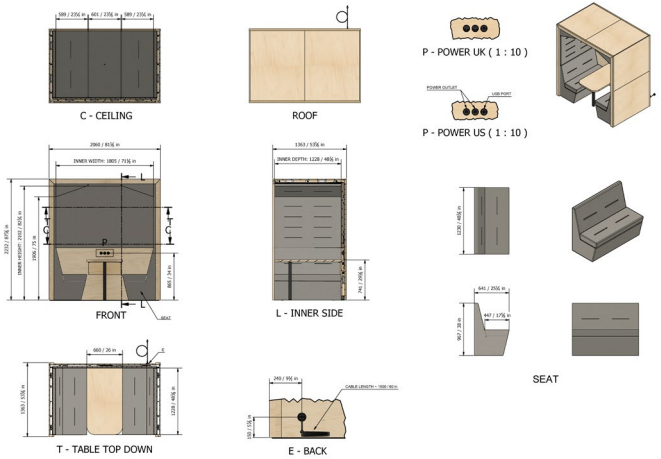

4 Person, Flat Roof, Upholstered Back, with Striplight

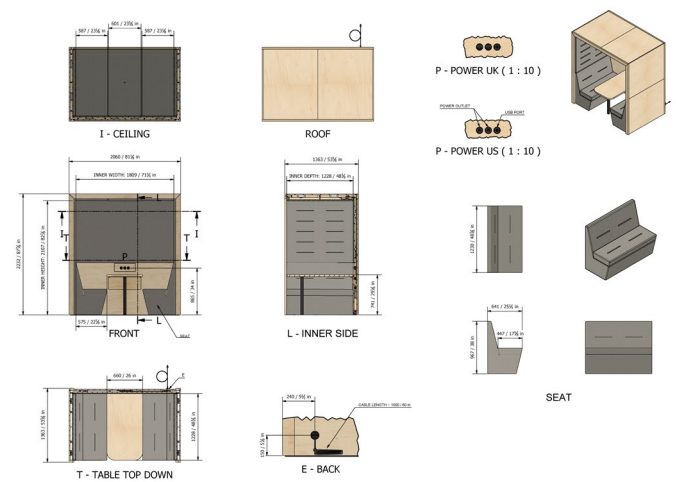

TECHNICAL DATA

Railway Carriage

2 Person, Arch Roof, Open Back, with Pendant

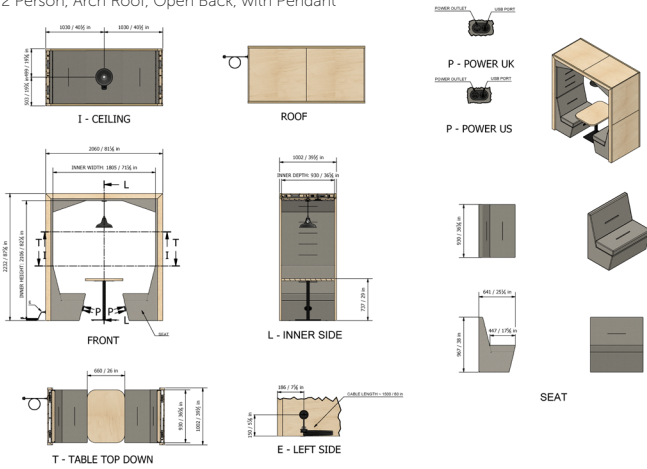

2 Person, Flat Roof, Open Back, with Pendant

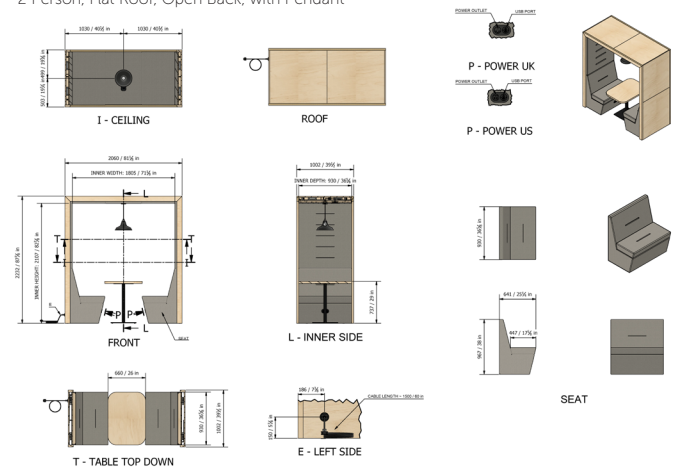

2 Person, Arch Roof, Open Back, with Spotlight

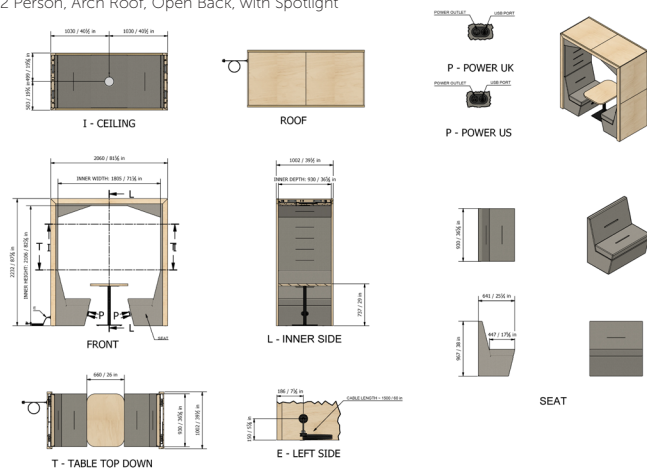

2 Person, Flat Roof, Open Back, with Spotlight

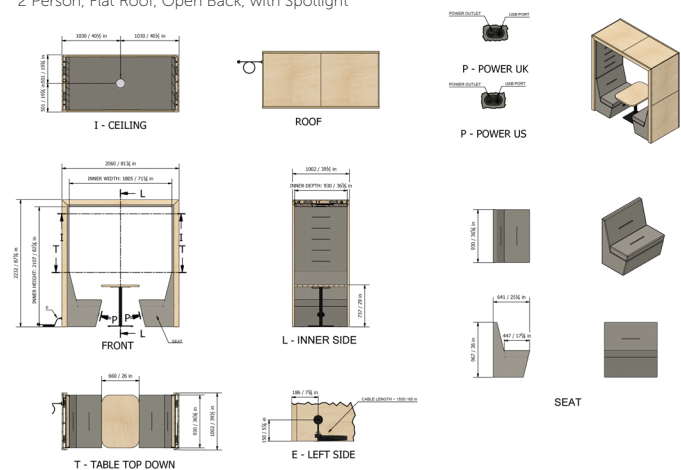

2 Person, Arch Roof, Open Back, with Striplight

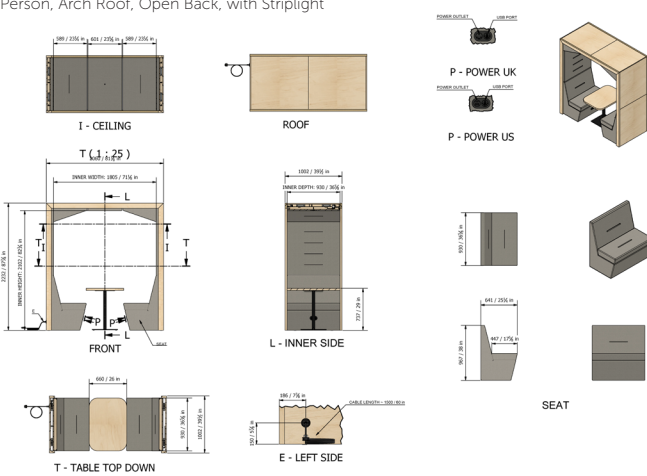

2 Person, Flat Roof, Open Back, with Striplight

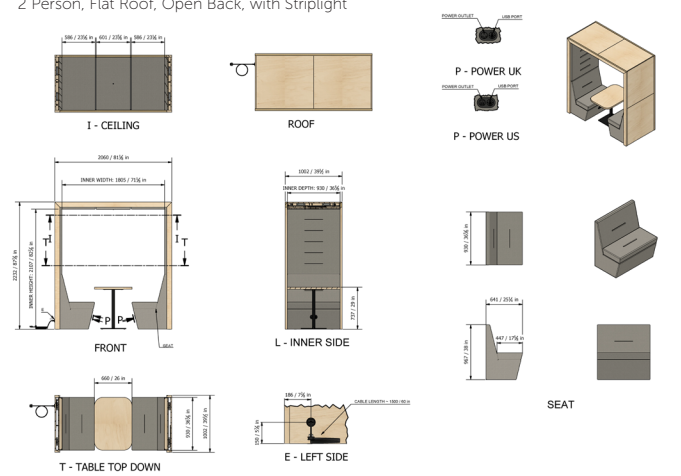

TECHNICAL DATA

Railway Carriage

4 Person, Arch Roof, Open Back, with Spotlights

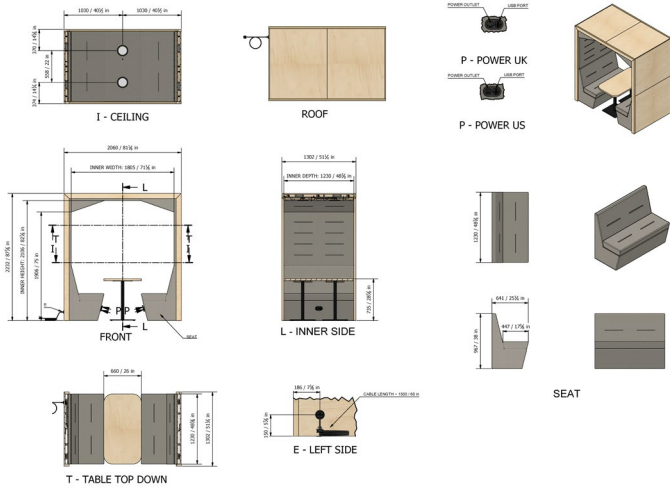

2 Person Banquette

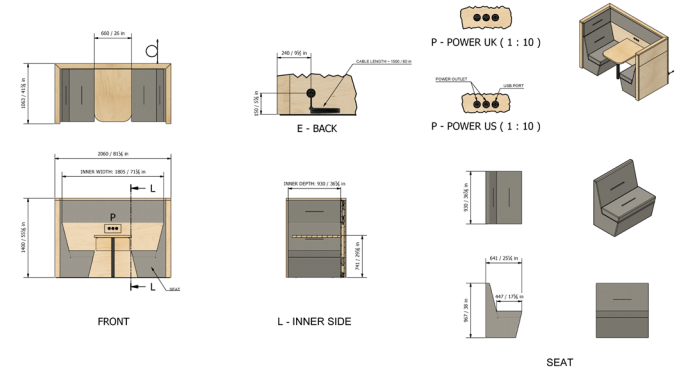

4 Person, Arch Roof, Open Back, with Pendant

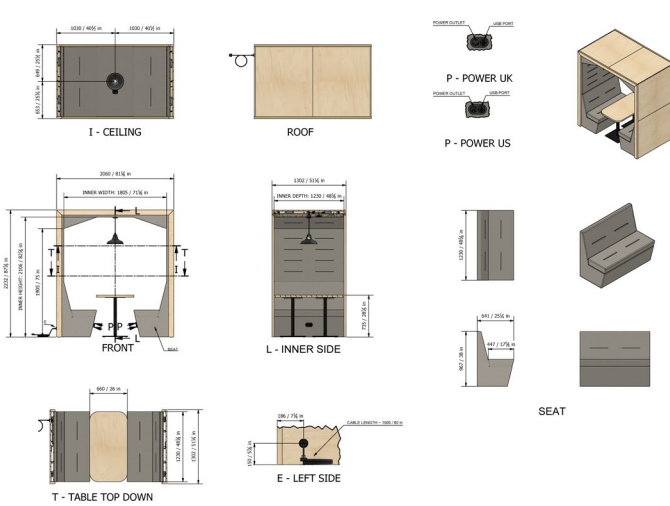

4 Person Banquette

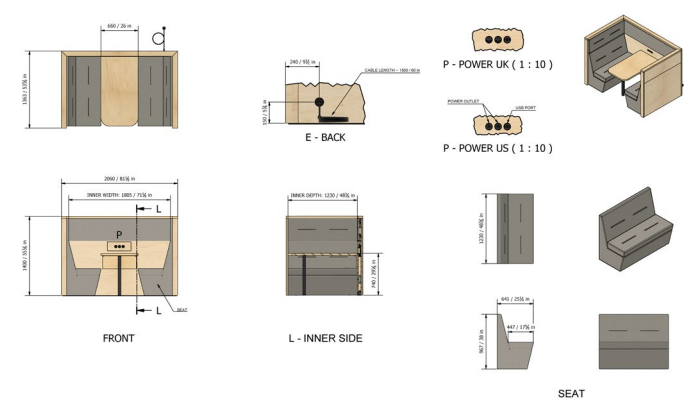

4 Person, Arch Roof, Open Back, with Striplight

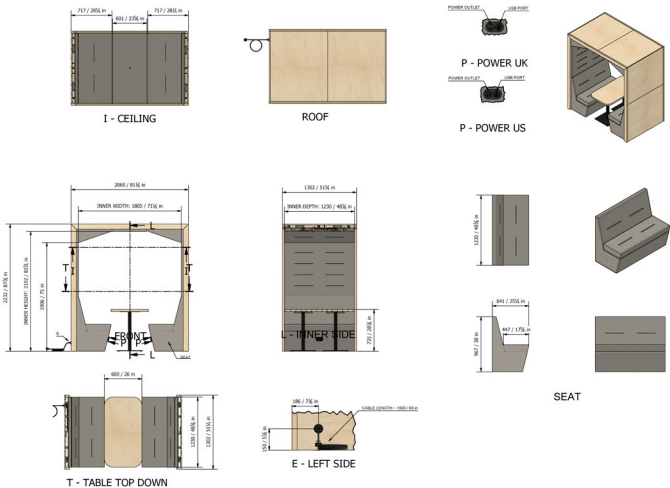

Railway Carriage

2 Person Upholstered Back Flat Roof with Spotlight

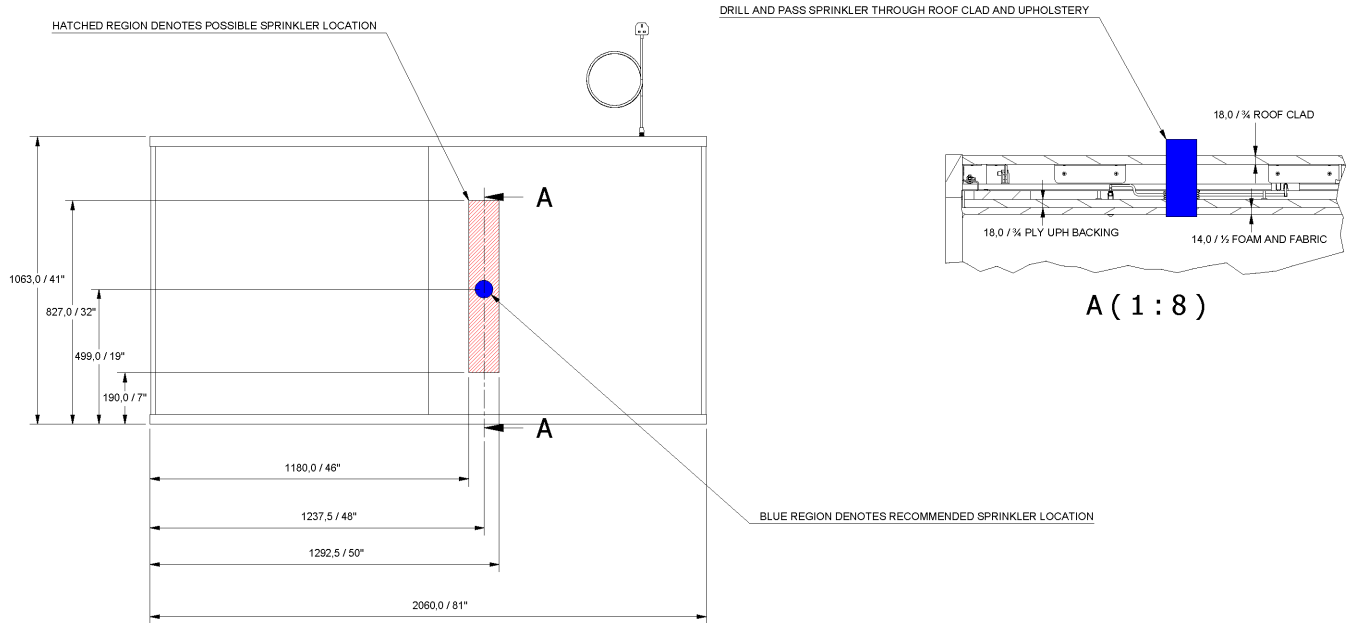

2 Person Open Back Flat Roof with Pendant

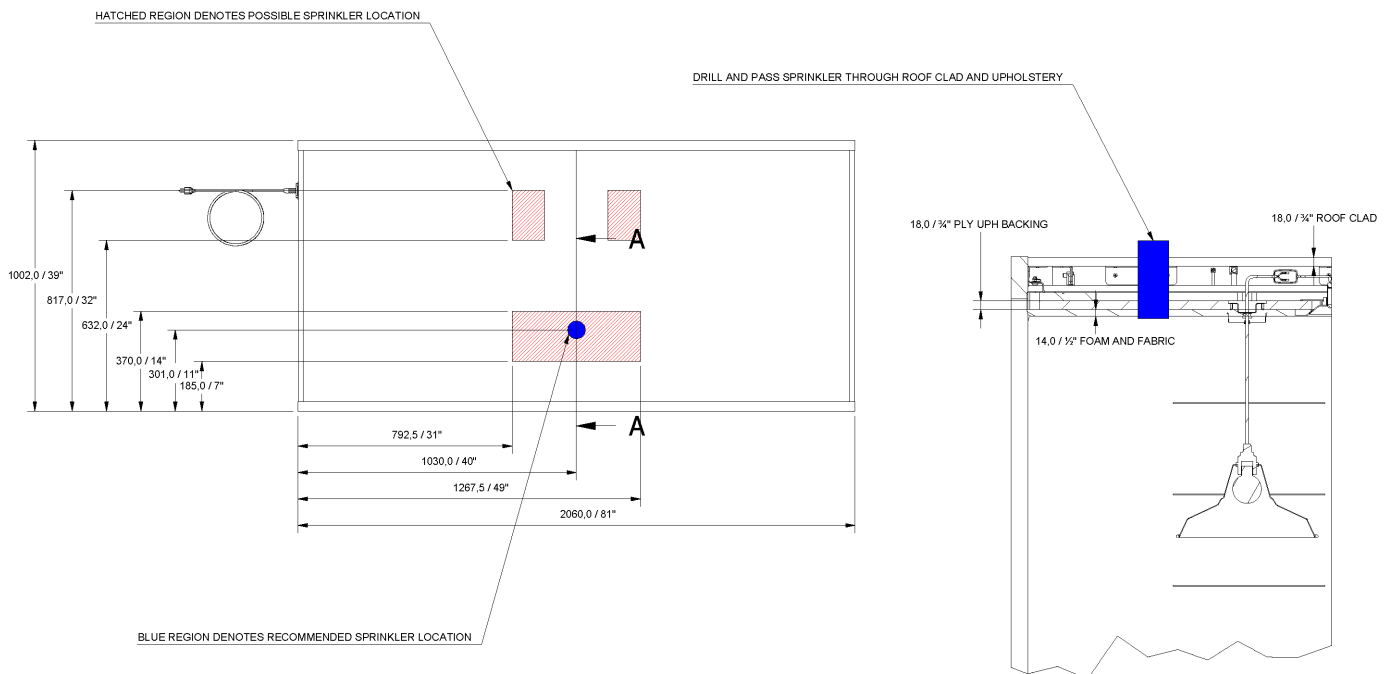

TECHNICAL DATA

Railway Carriage

4 Person Upholstered Back Flat Roof with Striplight

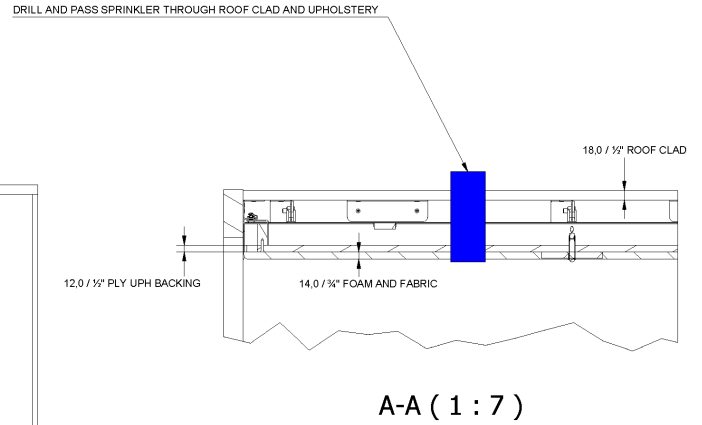
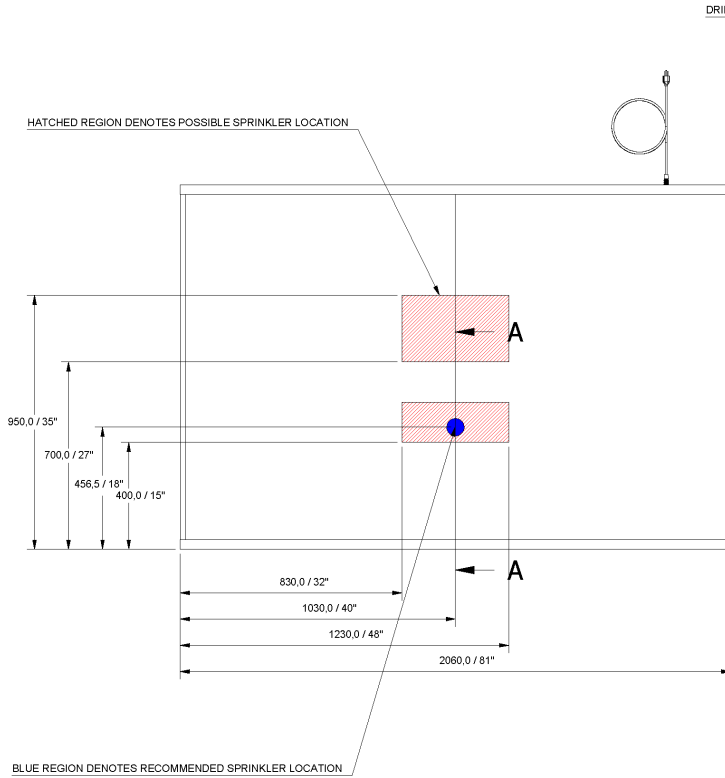

4 Person Open Back Arch Roof with Spotlight

