



MANUFACTURED BY:  
Backyard Discovery  
3305 Airport Drive, Pittsburg, KS 66762  
800-856-4445

Basepoint Business Centre: Rivermead Drive, Westlea, Swindon SN5 7EX Phone: 0800-118-2476  
J.P. Coenstraat 7, The Bridge, The Hague, 2595 WP, Netherlands Phone: 0800-567-8990

# EDGEWOOD

## Swing Set Model # 2500259

The assembly manual must be retained  
since it contains important information



### WARNING

**Adult Assembly Required.**

Not suitable for children under 36 months due to small parts.

**FOR DOMESTIC USE ONLY. INTENDED FOR OUTDOOR USE.**

CAN ICES-003 (B)/NMB-003(B)



**Please visit [www.backyarddiscovery.com](http://www.backyarddiscovery.com)**

For the most up to date assembly manual, to register your set, or to order replacement parts

*Para obtener instrucciones en español, visite [www.backyarddiscovery.com](http://www.backyarddiscovery.com)*



**EASY STEP-BY-STEP  
3D INTERACTIVE INSTRUCTIONS**  
DOWNLOAD THE FREE APP



# Owner's Manual - Basic Setup Dimensions & Assembly Notes

Place the set on level ground, not less than 6'-7" [2007 mm] from any structure or obstruction such as a fence, garage, house, overhanging branches, laundry lines, or electrical wires.

- While assembling unit, take time before and after each phase to make sure fort is level. If fort is not level, assembly will be difficult and improper assembly may result. Extra care must be taken to insure the fort is square.
- The safe play area refers to a zone extending 6'-7" (2007 mm) beyond the play product on all sides, including the space above the play product.

## SAFE PLAY AREA DIAGRAM

### Ground Dimensions

### Safe Play Area

16'-0" [4878 mm] x 16'-1 3/4" [4924 mm] x 9'-4 1/2" [2858 mm]    28'-2 1/2" [8596 mm] x 28'-7 3/4" [8731 mm] x 15'-11 1/4" [4858 mm]

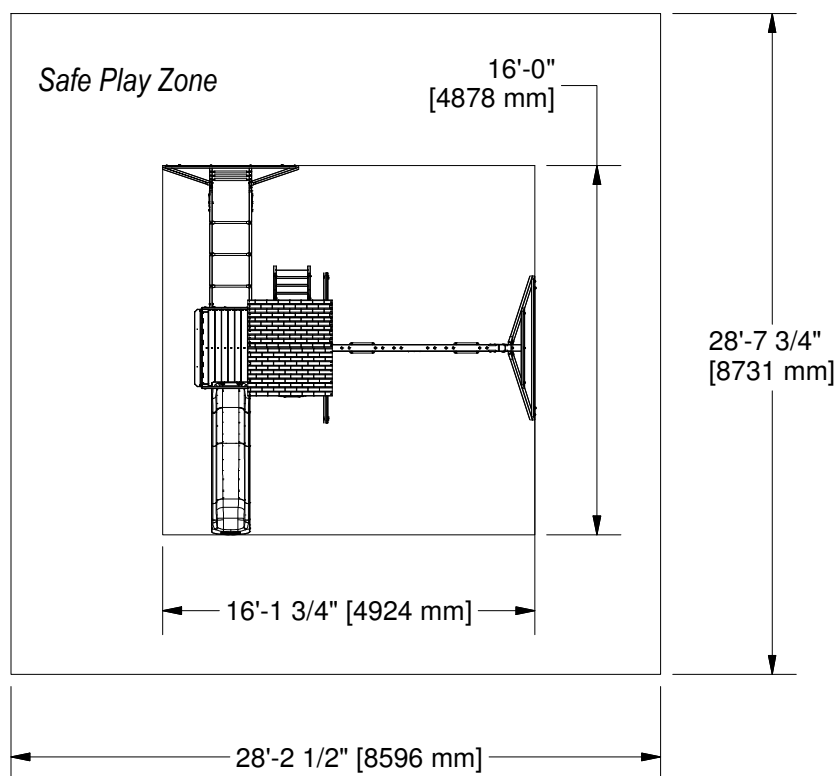

SAFE PLAY HEIGHT: 15'-11 1/4" [4858 mm]  
MAXIMUM FALL HEIGHT: 6' 4 1/2" [1942 mm]

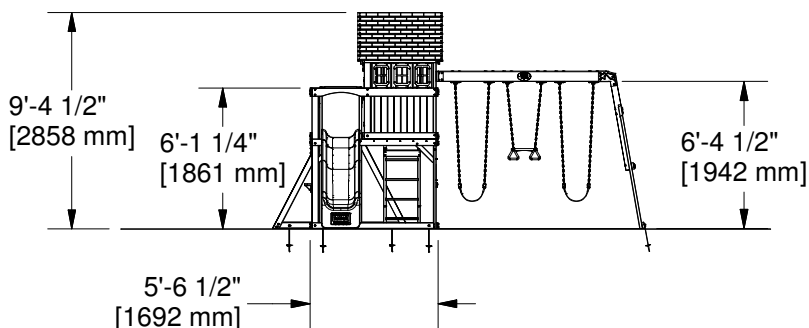

### General Information:

Your set has been designed and engineered for children only and for residential use only.  
A maximum of 150 lbs. per child is recommended for play activities designed for individual use.  
A maximum of 120 lbs. per child is recommended for play activities designed for multiple child use.  
A maximum of 8 children is recommended for this swing set.

# Owner's Manual - Parts Identification

## Wood Components (Not to Scale)



**A01 SWING BEAM EXTENDED - W4L21496**  
(x1) 3 3/8"x5 1/4"x89 1/2" (86x134x2274)

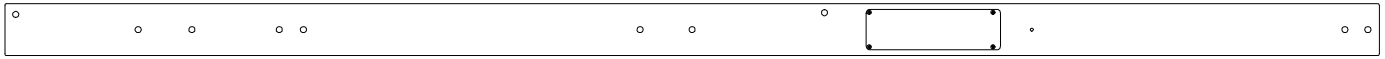

**E1 UPRIGHT ASSEMBLY - W2A05150**  
(x1) 1 3/8"x3 3/8"x89 1/2" (36x86x2274)



**E2 UPRIGHT - W4L22705**  
(x1) 1 3/8"x3 3/8"x73 1/8" (36x86x1856)

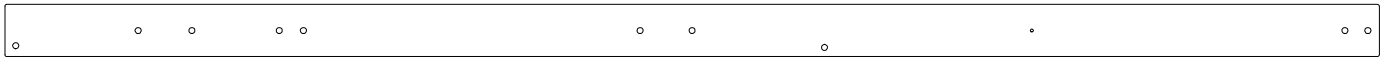

**E3 UPRIGHT - W4L22704**  
(x1) 1 3/8"x3 3/8"x89 1/2" (36x86x2274)



**E4 CLUB HOUSE LEG - W4L14534**  
(x1) 1 3/8"x3 3/8"x43 1/8" (36x86x1094)



**E5 UPRIGHT - W4L22706**  
(x1) 1 3/8"x3 3/8"x73 1/8" (36x86x1856)



**E6 MONKEY BAR UPRIGHT - W4L22700**  
(x2) 1 3/8"x3 3/8"x71 3/8" (36x86x1812)



**E7 ANGLE BRACE - W4L22726**  
(x2) 1 3/8"x3 3/8"x74 3/8" (36x86x1890)



**E8 CLUB HOUSE LEG - W4L14537**  
(x1) 1 3/8"x3 3/8"x43 1/8" (36x86x1094)



**E71 MONKEY BAR RAIL - W4L22703**  
(x2) 1 3/8"x3 3/8"x60 5/8" (36x86x1539)



**G1 COUNTER TOP - W4L22684**  
(x1) 1"x5 1/4"x40 3/8" (24x134x1024)



**G2 WALL RAIL - W4L22687**  
(x2) 1"x4 3/8"x40 3/4" (24x112x1034)



**H1 TABLE SUPPORT - W4L14543**  
(x2) 1"x2"x4" (24x51x102)

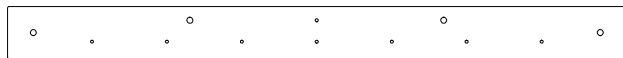

**H2 FLOOR SUPPORT - W4L22676**  
(x1) 1"x3 3/8"x40 3/8" (24x86x1024)



**H4 FLOOR SUPPORT - W4L22678**  
(x1) 1"x3 3/8"x40 3/8" (24x86x1024)

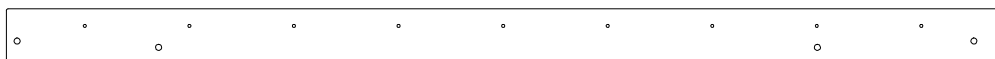

**H3 FLOOR SUPPORT - W4L22677**  
(x1) 1"x3 3/8"x64 3/4" (24x86x1644)

# Owner's Manual - Parts Identification

## Wood Components (Not to Scale)

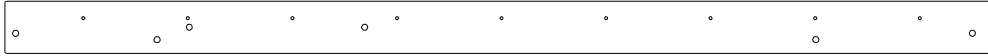

**H5 FLOOR SUPPORT - W4L22679**  
(x1) 1"x3 3/8"x64 3/4" (24x86x1644)



**H6 FLOOR SUPPORT - W4L22680**  
(x1) 1"x3 3/8"x40 3/8" (24x86x1024)



**H7 FLOOR SUPPORT - W4L22681**  
(x1) 1"x3 3/8"x37 1/2" (24x86x951)



**H8 FLOOR SUPPORT - W4L22682**  
(x1) 1"x3 3/8"x40 3/8" (24x86x1024)



**H9 WALL RAIL - W4L22683**  
(x1) 1"x3 3/8"x8 1/2" (24x86x216)



**H10 WALL RAIL - W4L22685**  
(x1) 1"x3 3/8"x6 3/4" (24x86x173)



**H11 WALL RAIL - W4L22686**  
(x1) 1"x3 3/8"x4 3/4" (24x86x122)



**H12 WALL RAIL - W4L22697**  
(x2) 1"x3 3/8"x40 3/8" (24x86x1024)



**H13 ROOF RAFTER - W4L22698**  
(x4) 1"x3 3/8"x34 1/4" (24x86x871)



**H14 WALL RAIL - W4L22699**  
(x2) 1"x3 3/8"x37 1/2" (24x86x951)



**H15 WALL RAIL - W4L22709**  
(x1) 1"x3 3/8"x11 5/8" (24x86x265)



**H74 LEFT UPRIGHT - W4L17611**  
(x1) 1 3/8"x3 3/8"x50 3/4" (36x86x1290)

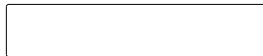

**H81 LADDER RUNG - W4L14554**  
(x4) 1"x3 3/8"x17 1/8" (24x86x434)

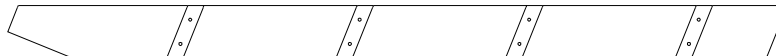

**H75 RIGHT UPRIGHT - W4L17612**  
(x1) 1 3/8"x3 3/8"x50 3/4" (36x86x1290)



**H82 ATTACHMENT BOARD - W4L17613**  
(x1) 1"x3 3/8"x19 1/8" (24x86x486)



**HB1 GROUND BOARD - W4L22671**  
(x1) 1"x3"x78 1/4" (24x76x1986)



**HB2 GROUND BOARD - W4L22672**  
(x2) 1"x3"x64 3/4" (24x76x1644)

# Owner's Manual - Parts Identification

## Wood Components (Not to Scale)



**HB3 GROUND BOARD - W4L22673**  
(x1) 1"x3"x40 3/8" (24x76x1024)

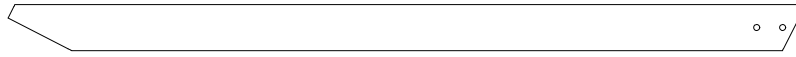

**HB4 MONKEY BAR BRACE - W4L22701**  
(x2) 1 1/8"x3"x52" (30x76x1320)



**HB5 MONKEY BAR GROUND BOARD - W4L22702**  
(x1) 1"x3"x70 3/4" (24x76x1798)



**K3 FLOOR SUPPORT - W4L14559**  
(x1) 5/8"x5 1/4"x40 3/8" (16x134x1024)



**K6 WALL BOARD - W4L14562**  
(x1) 5/8"x5 1/4"x16 1/4" (16x134x412)



**L5 CLUB HOUSE WALL RAIL - W4L14567**  
(x1) 5/8"x4 3/8"x40 3/8" (16x112x1024)



**L6 BAY WINDOW HEADER - W4L14568**  
(x2) 5/8"x4 3/8"x30 1/2" (16x112x774)



**L7 DOOR BOARD - W4L22711**  
(x1) 5/8"x4 3/8"x35" (16x110x890)



**L8 DOOR BOARD - W4L14570**  
(x1) 5/8"x4 3/8"x35" (16x110x890)



**M2 FLOOR SUPPORT - W4L14572**  
(x1) 5/8"x3 3/8"x40 3/8" (16x86x1024)



**M4 FLOOR BOARD - W4L14574**  
(x2) 5/8"x3 3/8"x40 3/8" (16x86x1024)

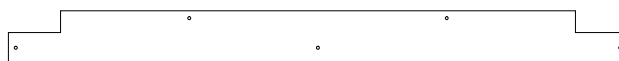

**M5 FLOOR BOARD - W4L22777**  
(x1) 5/8"x3 3/8"x40 3/8" (16x86x1024)



**M6 FLOOR BOARD - W4L22778**  
(x1) 5/8"x3 3/8"x37 1/2" (16x86x952)

# Owner's Manual - Parts Identification

## Wood Components (Not to Scale)



**M9 WALL BOARD - W4L22707**  
(x2) 5/8"x3 3/8"x42 1/4" (16x86x1074)



**M10 WALL BOARD - W4L22708**  
(x9) 5/8"x3 3/8"x22 1/4" (16x86x566)



**M12 WALL BOARD - W4L14582**  
(x9) 5/8"x3 3/8"x38 7/8" (16x86x986)



**M13 WALL BOARD - W4L14583**  
(x9) 5/8"x3 3/8"x22" (16x86x558)



**M14 WALL BOARD - W4L22712**  
(x1) 5/8"x3"x36 1/2" (16x76x926)



**M19 WALL BOARD - W4L14589**  
(x2) 5/8"x3 3/8"x40 5/8" (16x86x1032)



**M20 WALL BOARD - W4L14590**  
(x2) 5/8"x3 3/8"x16 1/4" (16x86x412)



**M22 WALL BOARD - W4L14592**  
(x1) 5/8"x2 7/8"x38 7/8" (16x73x986)



**M23 DOOR BOARD - W4L14593**  
(x2) 5/8"x3 3/8"x35 3/4" (16x86x908)



**M24 DOOR BOARD - W4L14594**  
(x2) 5/8"x3 3/8"x21 1/4" (16x86x540)



**M25 DOOR BOARD - W4L14595**  
(x2) 5/8"x3 3/8"x6 1/4" (16x86x160)



**M26 WALL BOARD - W4L14596**  
(x8) 5/8"x3 3/8"x3 1/2" (16x86x88)



**M31 GABLE BOARD - W4L14599**  
(x2) 5/8"x3 3/8"x31 1/2" (16x86x800)



**M33 WALL BOARD - W4L22710**  
(x1) 5/8"x3"x36 1/2" (16x76x926)

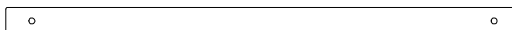

**M34 FILLER BOARD - W4L14617**  
(x1) 5/8"x1 3/4"x33 1/2" (16x45x851)

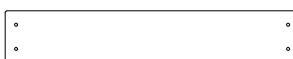

**M102 REAR SUPPORT - W4L17614**  
(x1) 5/8"x3 3/8"x19 1/8" (16x86x486)

# Owner's Manual - Parts Identification

## Wood Components (Not to Scale)



**N1 SAFETY BOARD - W4L14602**  
(x1) 5/8"x2 3/8"x40 3/8" (16x60x1024)



**N2 PICKET - W4L14603**  
(x6) 5/8"x2 3/8"x22" (16x60x558)

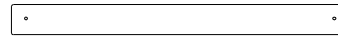

**N3 WALL BOARD - W4L14604**  
(x1) 5/8"x2"x22" (16x50x558)



**N4 BAY WINDOW BOARD - W4L14605**  
(x6) 5/8"x2 3/8"x13 1/8" (16x60x332)



**N5 BAY WINDOW BOARD - W4L14606**  
(x6) 5/8"x2 3/8"x6 1/4" (16x60x158)

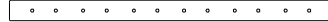

**O1 DOOR CLEAT - W4L14609**  
(x3) 5/8"x1 3/8"x21" (16x34x534)



**O2 WALL BOARD - W4L14610**  
(x2) 5/8"x1 3/8"x15 1/2" (16x34x395)



**OB01 GROUND BOARD - W4L21477**  
(x1) 1 1/8"x3"x74 3/4" (30x76x1900)



**OG01 END SUPPORT - W4L21476**  
(x1) 1"x3 1/2"x42" (30x86x1061)



**OG03 ANGLE BRACE - W4L22674**  
(x2) 1 3/16"x3 3/8"x47" (30x86x1194)



**OJ01 SWING BEAM MOUNT - W4L22696**  
(x1) 1 1/8"x5 1/4"x40 3/8" (30x134x1024)



**OR01 DECK BRACE - W4L22675**  
(x6) 1 1/8"x2 3/8"x14 5/8" (30x60x371)



**OR02 JOIST - W4L22691**  
(x1) 1 1/8"x2 3/8"x64 3/4" (30x60x1644)



**Q1 WALL RAIL - W4L22692**  
(x1) 1"x4 3/8"x40 3/8" (24x112x1024)

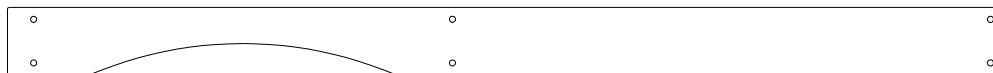

**Q2 WALL RAIL - W4L22693**  
(x1) 1"x4 3/8"x64 3/4" (24x112x1644)



**Q3 WALL RAIL - W4L22694**  
(x1) 1"x4 3/8"x40 3/8" (24x112x1024)

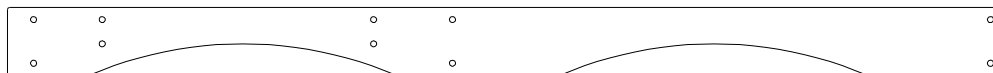

**Q4 WALL RAIL - W4L22695**  
(x1) 1"x4 3/8"x64 3/4" (24x112x1644)

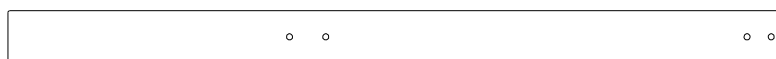

**SP01 SWING BEAM SUPPORT - W4L21497**  
(x1) 3 3/8"x3 3/8"x50 5/8" (86x86x1286)

# Owner's Manual - Parts Identification

## Wood Components (Not to Scale)



**T1 FLOOR SUPPORT - W4L22688**  
(x1) 1"x1 1/8"x33 1/2" (24x30x852)



**T3 FLOOR SUPPORT - W4L22690**  
(x1) 1 1/8"x1"x37 1/2" (30x24x952)



**T2 FLOOR SUPPORT - W4L22689**  
(x2) 1"x1 1/8"x59 7/8" (24x30x1522)



**Y1 WALL BOARD - W4L14616**  
(x2) 5/8"x4"x34 5/8" (16x102x880)



**FP1 FLOOR PANEL - W2A03131**  
(x3) 1 1/4"x17"x40 5/16" (32x432x1024)



**RP1 ROOF PANEL - W2A05151**  
(x2) 1 3/8"x19 3/8"x42 5/8" (35x491x1115)



**RP2 ROOF PANEL - W2A05152**  
(x2) 1 3/8"x16 1/8"x42 5/8" (35x410x1115)

# Owner's Manual - Parts Identification

## Hardware Components

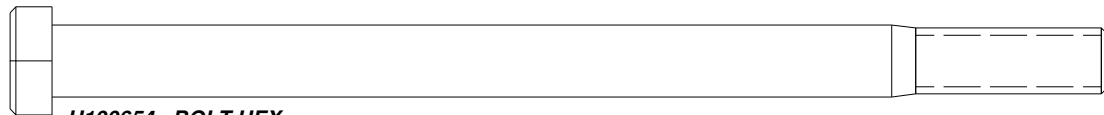

**H100654 BOLT HEX**  
(x12) 3/8x5-1/2

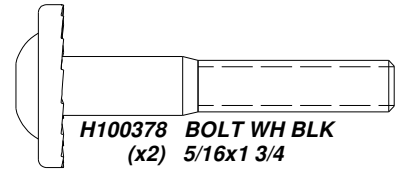

**H100378 BOLT WH BLK**  
(x2) 5/16x1 3/4

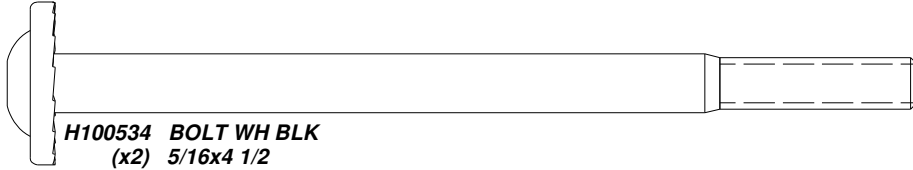

**H100534 BOLT WH BLK**  
(x2) 5/16x4 1/2

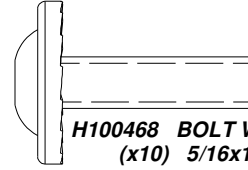

**H100468 BOLT WH BLK**  
(x10) 5/16x1

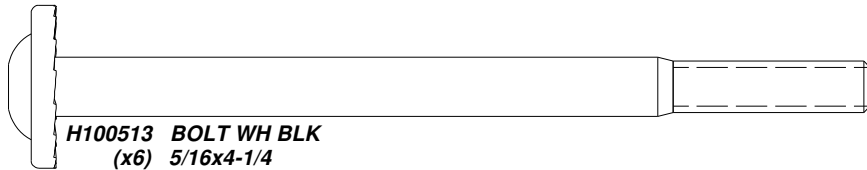

**H100513 BOLT WH BLK**  
(x6) 5/16x4-1/4

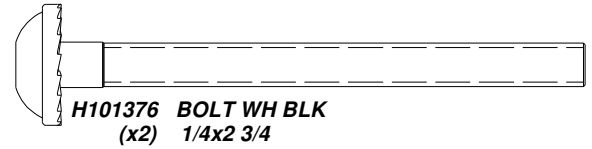

**H101376 BOLT WH BLK**  
(x2) 1/4x2 3/4

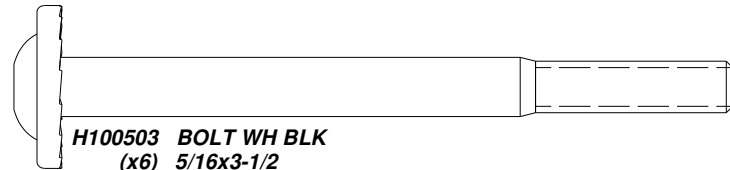

**H100503 BOLT WH BLK**  
(x6) 5/16x3-1/2

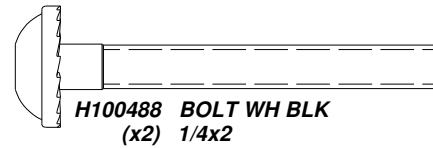

**H100488 BOLT WH BLK**  
(x2) 1/4x2

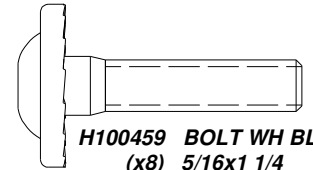

**H100459 BOLT WH BLK**  
(x8) 5/16x1 1/4

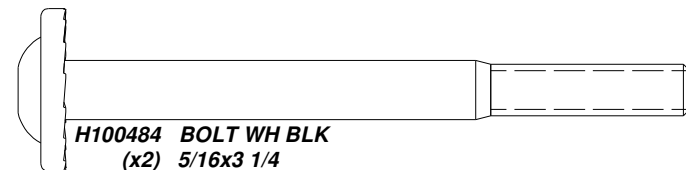

**H100484 BOLT WH BLK**  
(x2) 5/16x3 1/4

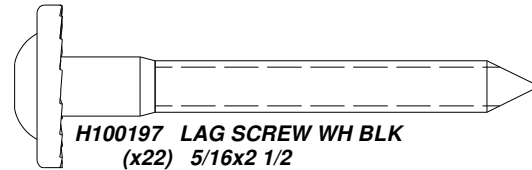

**H100197 LAG SCREW WH BLK**  
(x22) 5/16x2 1/2

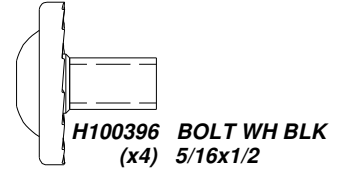

**H100396 BOLT WH BLK**  
(x4) 5/16x1/2

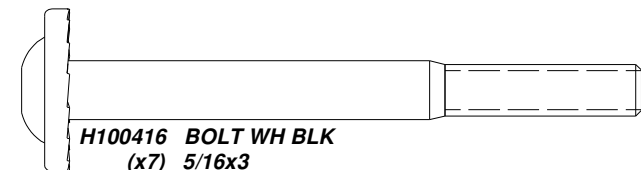

**H100416 BOLT WH BLK**  
(x7) 5/16x3

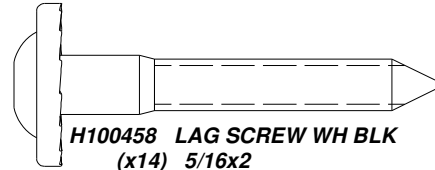

**H100458 LAG SCREW WH BLK**  
(x14) 5/16x2

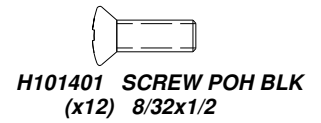

**H101401 SCREW POH BLK**  
(x12) 8/32x1/2

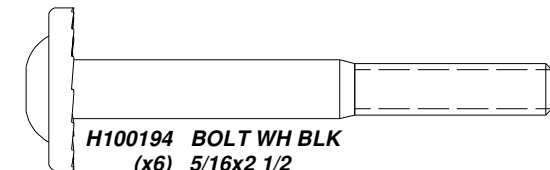

**H100194 BOLT WH BLK**  
(x6) 5/16x2 1/2

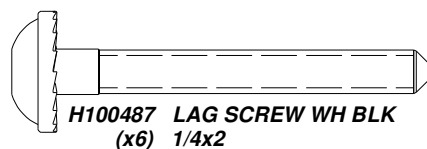

**H100487 LAG SCREW WH BLK**  
(x6) 1/4x2

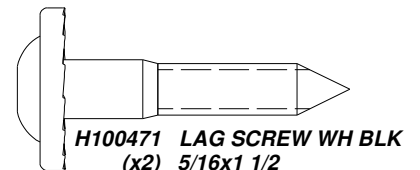

**H100471 LAG SCREW WH BLK**  
(x2) 5/16x1 1/2

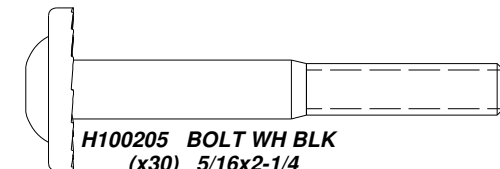

**H100205 BOLT WH BLK**  
(x30) 5/16x2-1/4

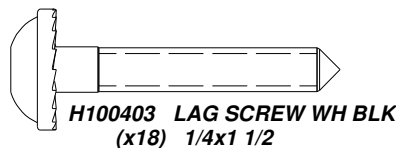

**H100403 LAG SCREW WH BLK**  
(x18) 1/4x1 1/2

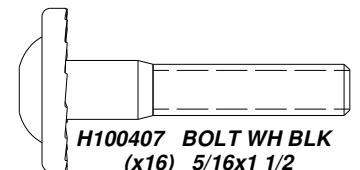

**H100407 BOLT WH BLK**  
(x16) 5/16x1 1/2

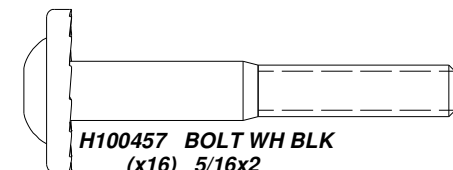

**H100457 BOLT WH BLK**  
(x16) 5/16x2

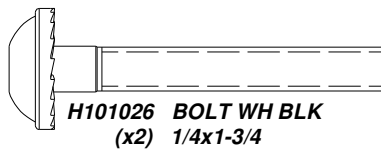

**H101026 BOLT WH BLK**  
(x2) 1/4x1-3/4



**H100775 BOLT HEX**  
(x4) 5/16x2-3/4

# Owner's Manual - Parts Identification

## Hardware Components

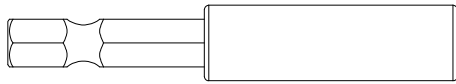

**H101100 MAGNETIC DRIVER**  
(x1)

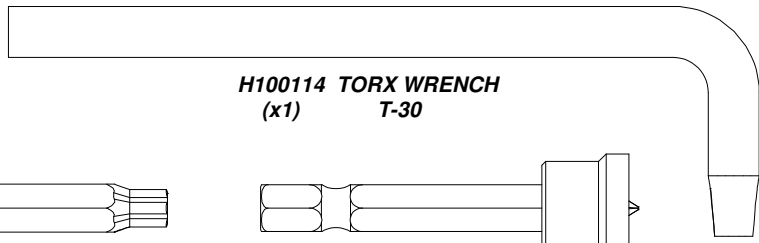

**H100114 TORX WRENCH**  
(x1) T-30

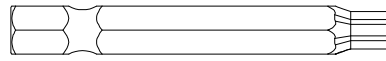

**H100147 TORX BIT**  
(x1) T-30

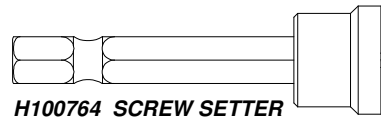

**H100764 SCREW SETTER**  
(x1)

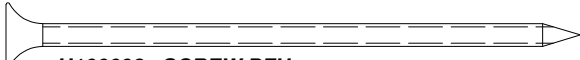

**H100092 SCREW PFH**  
(x4) 8x3

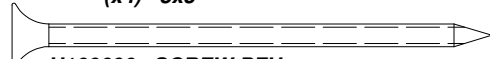

**H100090 SCREW PFH**  
(x16) 8x2 1/2"



**H100111 SCREW PFH**  
(x6) 8x2

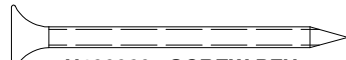

**H100089 SCREW PFH**  
(x36) 8x1 3/4

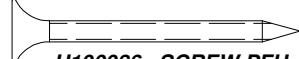

**H100086 SCREW PFH**  
(x121) 8x1 1/2

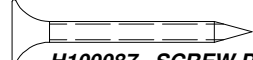

**H100087 SCREW PFH**  
(x3) 8x1 1/4

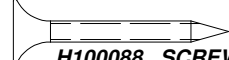

**H100088 SCREW PFH**  
(x270) 8x1 1/8

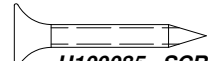

**H100085 SCREW PFH**  
(x4) 8x1

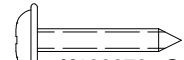

**H100070 SCREW PWH**  
(x36) 8x3/4

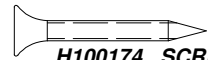

**H100174 SCREW PFH**  
(x2) 6x1

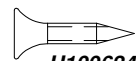

**H100624 SCREW PFH BLK**  
(x2) 6x5/8

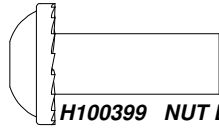

**H100399 NUT BARREL WH BLK**  
(x2) 1/4x7/8



**H101272 NUT BARREL PTH BLK**  
(x12) 8x32

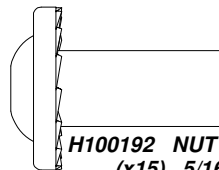

**H100192 NUT BARREL WH BLK**  
(x15) 5/16x7/8

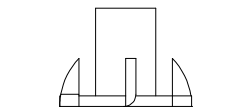

**H100398 T-NUT BLK**  
(x4) 1/4

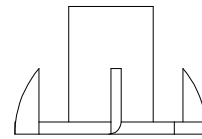

**H100073 T-NUT**  
(x12) 3/8

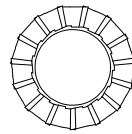

**H100400 WASHER LOCK EXT BLK**  
(x2) 8x15

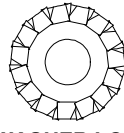

**H100405 WASHER LOCK EXT BLK**  
(x16) 6x15

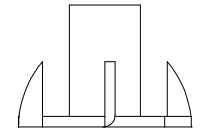

**H100379 T-NUT BLK**  
(x104) 5/16

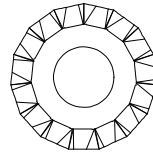

**H100198 WASHER LOCK EXT BLK**  
(x104) 8x19

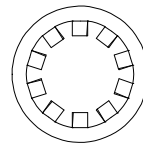

**H100107 WASHER LOCK INT**  
(x12) 10x18

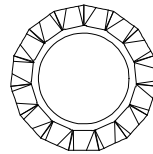

**H100199 WASHER LOCK EXT BLK**  
(x4) 12x19

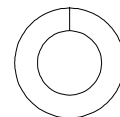

**H100477 WASHER SPLIT BLK**  
(x4) 5/16

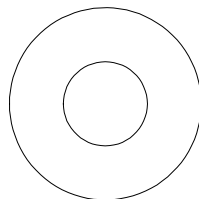

**H100102 WASHER FLAT**  
(x12) 11x25

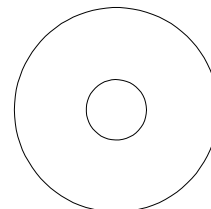

**H100478 WASHER FLAT BLK**  
(x4) 8x27

# Owner's Manual - Parts Identification

## Accessory Components (Not to Scale)

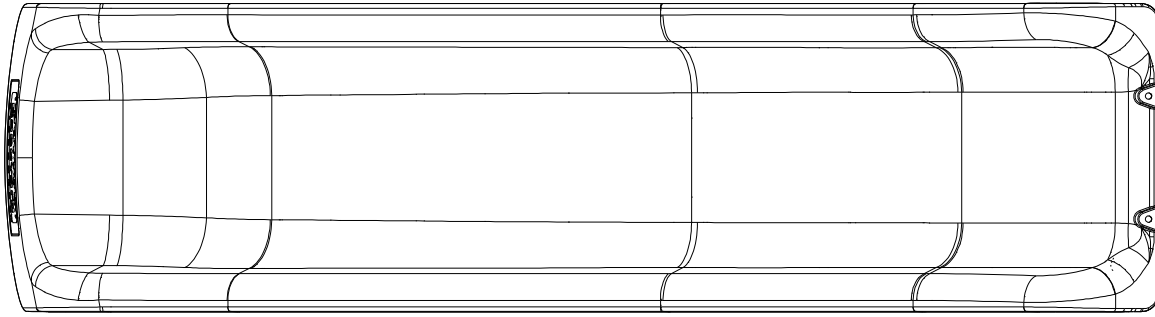

**A6P00525 8' BLOW MOLDED SLIDE - GREEN**  
(x1)

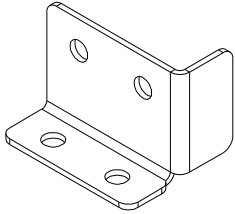

**A4M05883 SADDLE BRACKET - RIGHT**  
(x1)

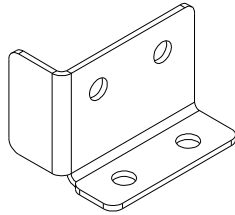

**A4M05884 SADDLE BRACKET - LEFT**  
(x1)

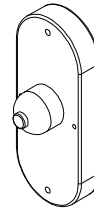

**A100174 DOOR BELL**  
(x1)

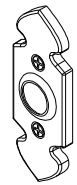

**A6P00290 DOOR BELL PLATE**  
(x1)

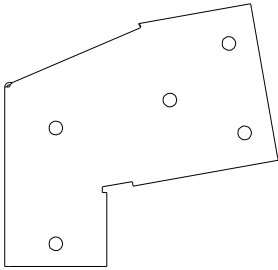

**A100326 SWING BEAM EXTENSION BRACKET-RIGHT**  
(x1)

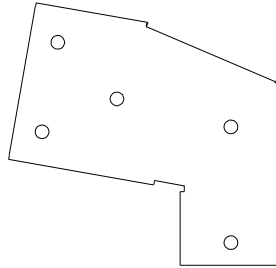

**A100325 SWING BEAM EXTENSION BRACKET-LEFT**  
(x1)

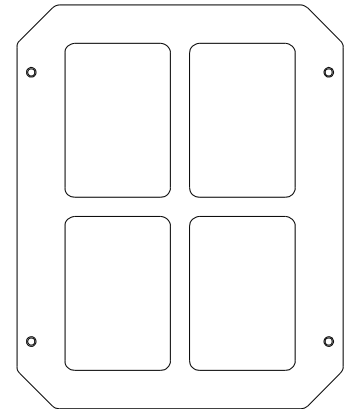

**A100014 PLASTIC WINDOW WHITE**  
(x6)

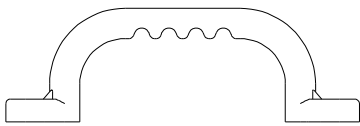

**A100028 HAND GRIP GREEN PLASTIC**  
(x4)

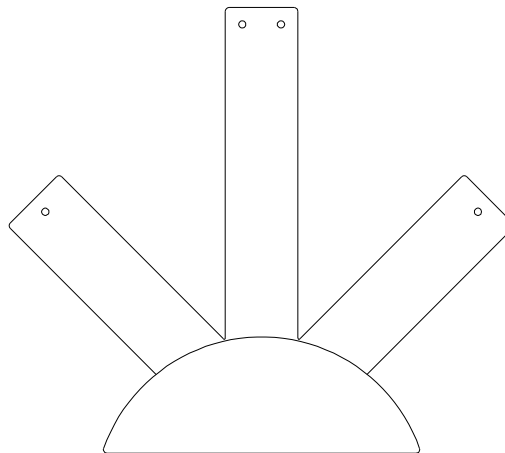

**A100361 PLASTIC SUNBURST**  
(x2)



**A100164 BYD ID TAG (LARGE)**  
(x1) AGES 3-10

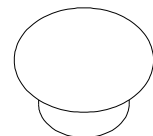

**A6P00122 KNOB - LT BROWN**  
(x1)

# Owner's Manual - Parts Identification

## Accessory Components (Not to Scale)

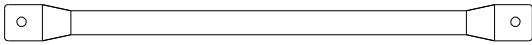

**A100045 METAL RUNG 559 GREEN**  
(x6)

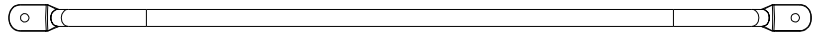

**A100134 HAND GRIP GREEN 816 C/C**  
(x2)



**A100068 CHAIN GREEN 51.25"**  
(x4)



**A100177 CHAIN GREEN 31"**  
(x2)

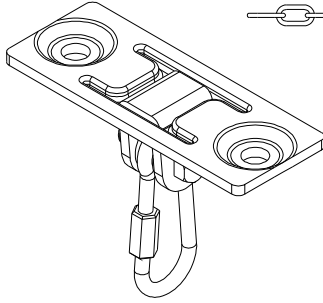

**A4M00505 SWING HANGER**  
(x6)

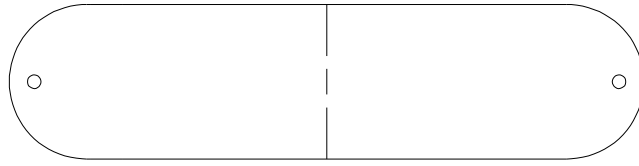

**A6P00054 SWING SEAT GREEN 22"**  
(x2)

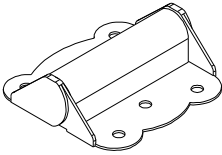

**A4M00624 HINGE (DOOR, SPRING LOADED)**  
(x2)

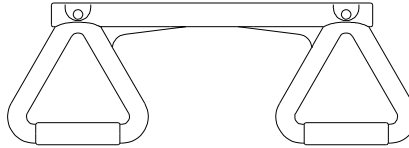

**A6P00034 TRAPEZE YELLOW**  
(x1)

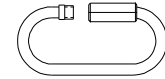

**A100069 QUICK LINK**  
(x6)

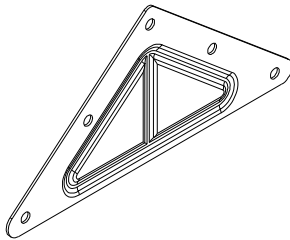

**A100294 TRIANGLE PLATE 100° 5 HOLE**  
(x2)

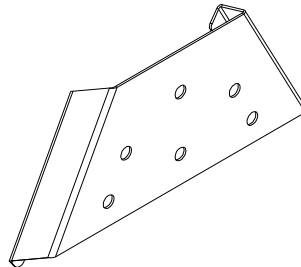

**A4M01169 A-FRAME BRACKET**  
(x1)

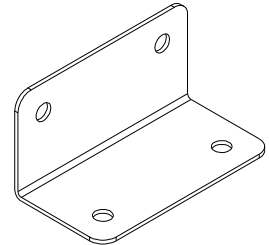

**A100140 L BRACKET 66x66x127**  
(x2)

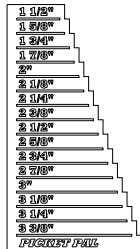

**A6P00410 PICKET PAL**  
(x1)

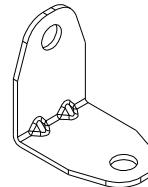

**A4M01046 L BRACKET 2.5x38x55x55**  
(x4)

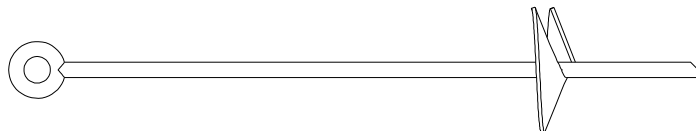

**A100178 AUGER GROUND STAKE**  
(x8)

# PRE-ASSEMBLY STEP 1 - SORTING PARTS

It is critical for ease of assembly that you take the time to sort and organize the wood and hardware.

---

## WOOD PARTS:

- Organize wood parts by the three-digit, alpha-numeric number stamped on each board (ex. P01).
- If there are multiple boards with the same stamped number, stack those pieces together.
- Stamps can be found on the flat surface of the boards or on the end of the boards.
- Allow yourself plenty of room - the wood pieces can take up a significant amount of space.

**NOTE: CARTONS ARE NOT ORGANIZED BY BOARD NUMBER.**

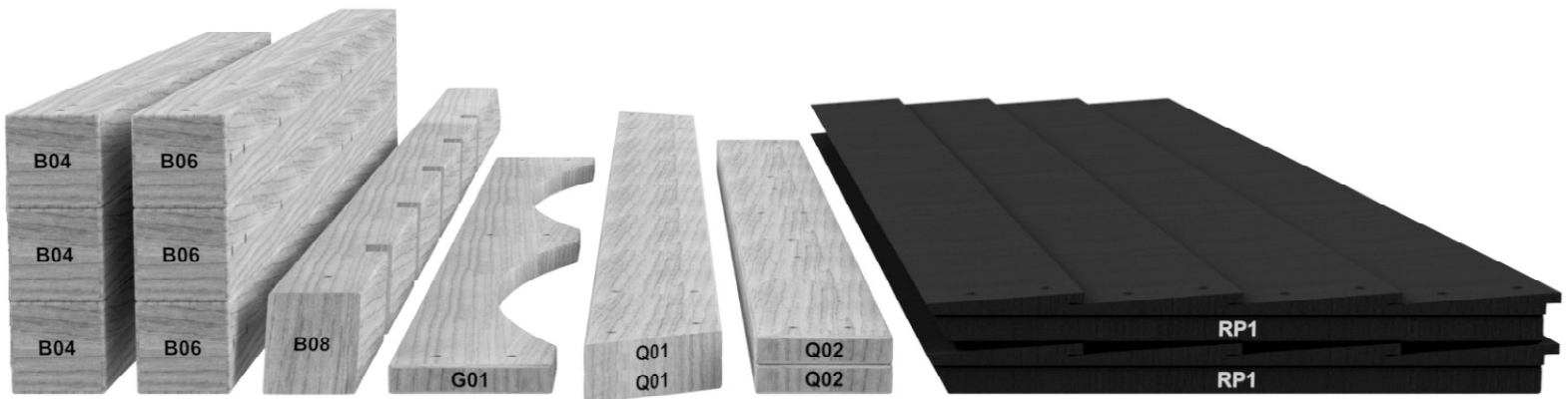

---

## HARDWARE PARTS:

- We recommend that you have a separate table to organize the hardware.
- Hardware bags are printed with a seven-digit, alpha-numeric part number.
- You can organize your hardware by part number or group by hardware type (i.e. bolts, nuts, etc.).
- During assembly you only need to reference the last four digits of the number.

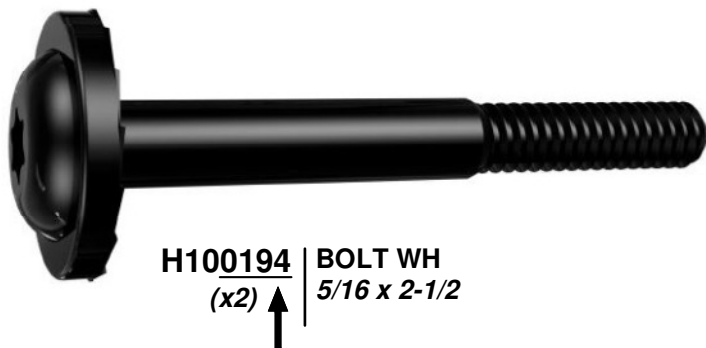

# PRE-ASSEMBLY STEP 2 - TOOLS REQUIRED



**Cordless Drill or  
Electric Drill**



**Drill Attachments:  
Phillips Head**



**1/8", 3/16", 3/8" & 7/16"  
Drill Bits**



**Phillips Screw Driver**



**Open End Wrenches 1/2" & 9/16"**



**3/8" Drive Ratchet, 1/2" &  
9/16" STD Sockets 1/2" & 9/16" Deep  
Sockets**



**Claw Hammer**



**Rubber Mallet - Optional**



**Tape Measure**

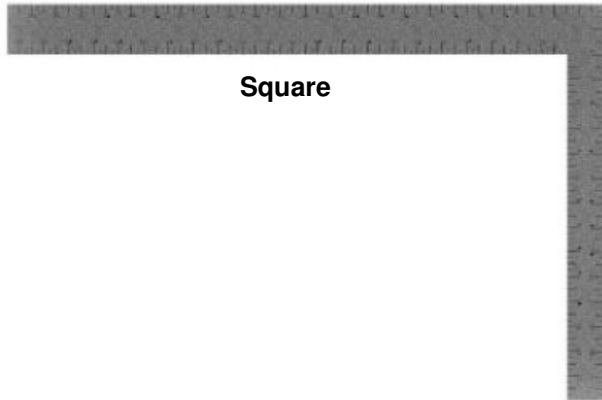

**Square**



**Level 24"**

# PRE-ASSEMBLY STEP 3 - CHOOSE YOUR ASSEMBLY METHOD

There are several types of assembly instructions available to you.

1. Printed Assembly Manual included with your set
2. BILT APP - 3D interactive instructions
3. Combination of the Printed Manual and BILT APP (Note: Step numbers can differ between the two methods)





SCAN FOR **BILT**. 3D INSTRUCTIONS



POWERED BY **BILT INTELLIGENT INSTRUCTIONS**®

**Scan for easy  
3D instructions**

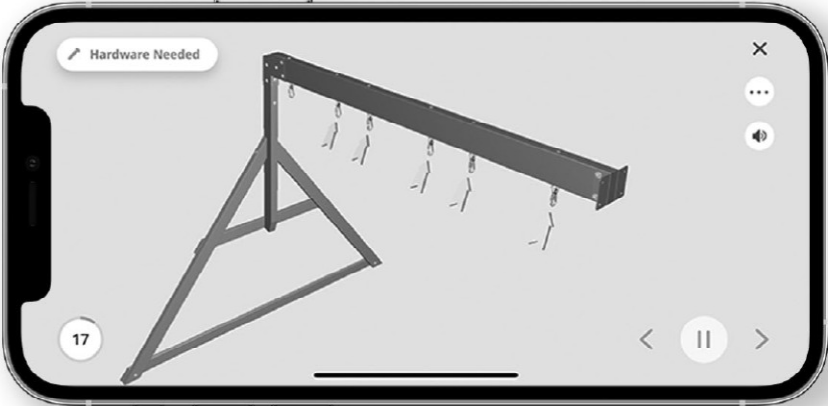
Download the BILT app  
before you begin



The image shows a smartphone screen displaying a 3D assembly instruction. At the top left of the screen, there is a button labeled "Hardware Needed". The main content is a 3D model of a metal frame structure. At the bottom left of the screen, the number "17" is displayed in a circle. At the bottom right, there are navigation icons: a back arrow, a pause button, and a forward arrow. The smartphone is shown with a slight shadow, giving it a 3D appearance.

# ELECTRONICS SAFETY WARNING

**Note:**

This equipment has been tested and found to comply with the limits for a Class B digital device, pursuant to part 15 of the FCC Rules. These limits are designed to provide reasonable protection against harmful interference in a residential installation. This equipment generates, uses and can radiate radio frequency energy and, if not installed and used in accordance with the instructions, may cause harmful interference to radio communications. However, there is no guarantee that interference will not occur in a particular installation. If this equipment does cause harmful interference to radio or television reception, which can be determined by turning the equipment off and on, the user is encouraged to try to correct the interference by one or more of the following measures:

- Reorient or relocate the receiving antenna.
- Increase the separation between the equipment and receiver.
- Connect the equipment into an outlet on a circuit different from that to which the receiver is connected.
- Consult the dealer or an experienced radio/TV technician for help

Caution: Changes or modifications not expressly approved by the party responsible for compliance could void the user's authority to operate the equipment.

# STEP 1 - A100174 BATTERY ASSEMBLY

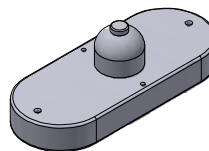

A100174 DOOR BELL  
(x1)

## NOTE:

- DO NOT MIX OLD AND NEW BATTERIES.
- DO NOT MIX ALKALINE, STANDARD (CARBON-ZINC), OR RECHARGEABLE (NI-CAD, NI-MH, ETC.) BATTERIES.
- NON-RECHARGEABLE BATTERIES ARE NOT TO BE RECHARGED.
- ONLY BATTERIES OF THE SAME OR EQUIVALENT TYPE AS RECOMMENDED ARE TO BE USED.
- BATTERIES ARE TO BE INSERTED WITH THE CORRECT POLARITY.
- EXHAUSTED BATTERIES ARE TO BE REMOVED FROM THE TOY OR IF THE TOY IS TO BE LEFT UNUSED FOR A LONG TIME.
- THE SUPPLY TERMINALS ARE NOT TO BE SHORT-CIRCUITED.



## FCC LABEL

### NOTE:

THIS DEVICE COMPLIES WITH PART 15 OF THE FCC RULES. OPERATION IS SUBJECT TO THE FOLLOWING TWO CONDITIONS: (1) THIS DEVICE MAY NOT CAUSE HARMFUL INTERFERENCE, (2) THIS DEVICE MUST ACCEPT ANY INTERFERENCE RECEIVED, INCLUDING INTERFERENCE THAT MAY CAUSE UNDESIRABLE OPERATION.

### NOTE:

USING A SCREW DRIVER, REPLACE BATTERIES BY REMOVING SCREW IN BATTERY COVER, REMOVING BATTERY COVER AND FOLLOWING DIRECTIONS FOR BATTERY REPLACEMENT LOCATED ON THE BATTERY COVER.

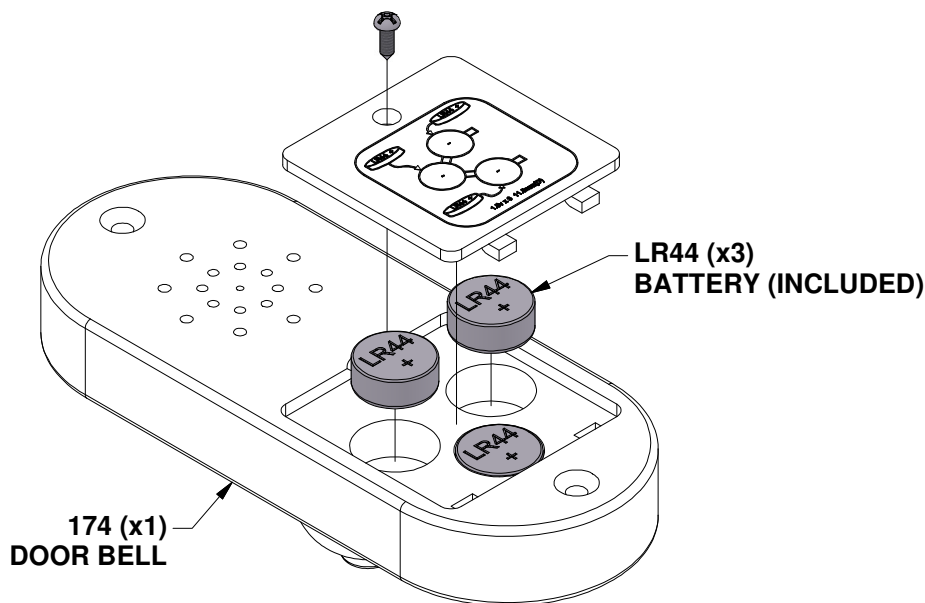

## WARNING:

1. KEEP BATTERIES OUT OF THE REACH OF CHILDREN.
2. SWALLOWING MAY LEAD TO SERIOUS INJURY OR DEATH IN AS LITTLE AS 2 HOURS, DUE TO CHEMICAL BURNS AND POTENTIAL PERFORATION OF THE ESOPHAGUS.
3. IF YOU SUSPECT YOUR CHILD HAS SWALLOWED A BUTTON BATTERY, IMMEDIATELY SEEK URGENT MEDICAL ASSISTANCE.
4. EXAMINE DEVICES AND MAKE SURE THE BATTERY COMPARTMENT IS CORRECTLY SECURED, E.G. THAT THE SCREW OR OTHER MECHANICAL FASTENER IS TIGHTENED. DO NOT USE IF COMPARTMENT IS NOT SECURE.
5. DISPOSE OF USED BUTTON BATTERIES IMMEDIATELY AND SAFELY. FLAT BATTERIES CAN STILL BE DANGEROUS.
6. TELL OTHER OF THE RISK ASSOCIATED WITH BUTTON BATTERIES AND HOW TO KEEP THEIR CHILDREN SAFE.

# STEP 1 - LADDER ASSEMBLY

QTY	PART NUMBER	DESCRIPTION
8	H100090	SCREW PFH 8x2 1/2



**H74** | LEFT UPRIGHT - W4L17611  
(x1) | 1 3/8"x3 3/8"x50 3/4" (36x86x1290)

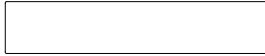

**H81** | LADDER RUNG - W4L14554  
(x4) | 1"x3 3/8"x17 1/8" (24x86x434)

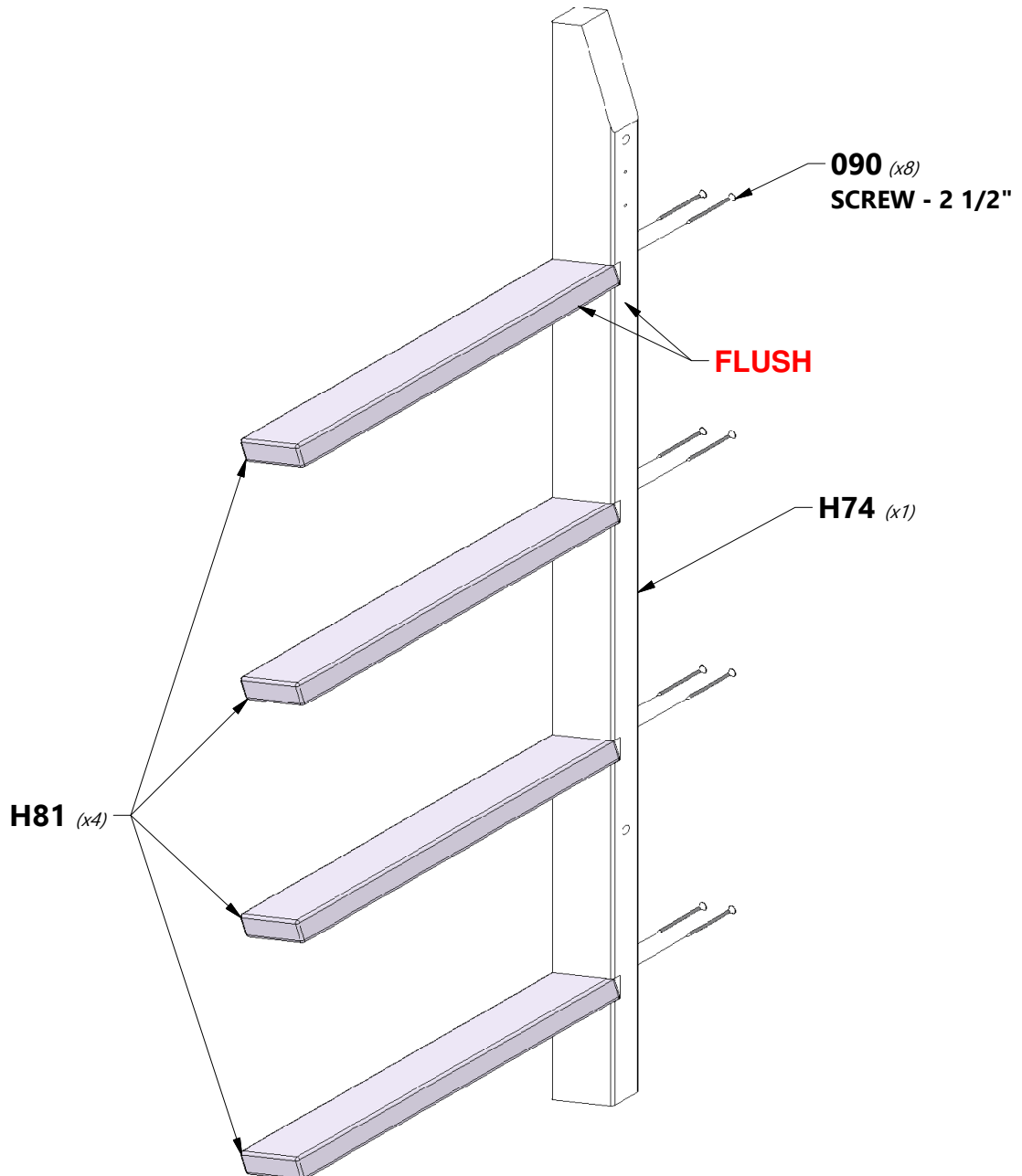

# STEP 2 - LADDER ASSEMBLY

QTY	PART NUMBER	DESCRIPTION
8	H100090	SCREW PFH 8x2 1/2



**H75 | RIGHT UPRIGHT - W4L17612**  
(x1) | 1 3/8"x3 3/8"x50 3/4" (36x86x1290)

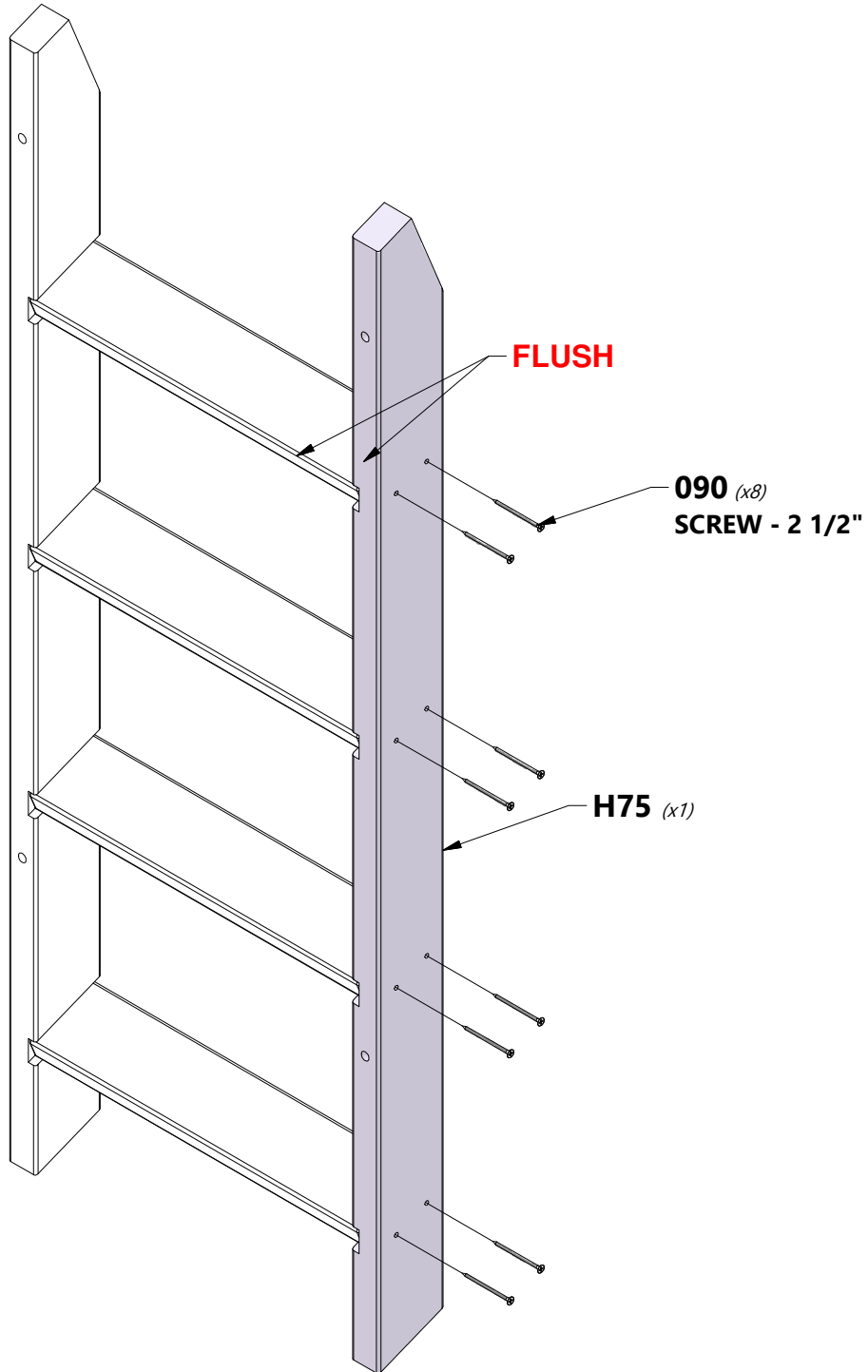

# STEP 3 - LADDER ASSEMBLY

QTY	PART NUMBER	DESCRIPTION
4	H100086	SCREW PFH 8x1-1/2"
4	H100089	SCREW PFH 8x1-3/4"



**M102** REAR SUPPORT - W4L17614  
(x1) 5/8"x3 3/8"x19 1/8" (16x86x486)



**H82** ATTACHMENT BOARD - W4L17613  
(x1) 1"x3 3/8"x19 1/8" (24x86x486)

**- ALIGN PILOT HOLES**

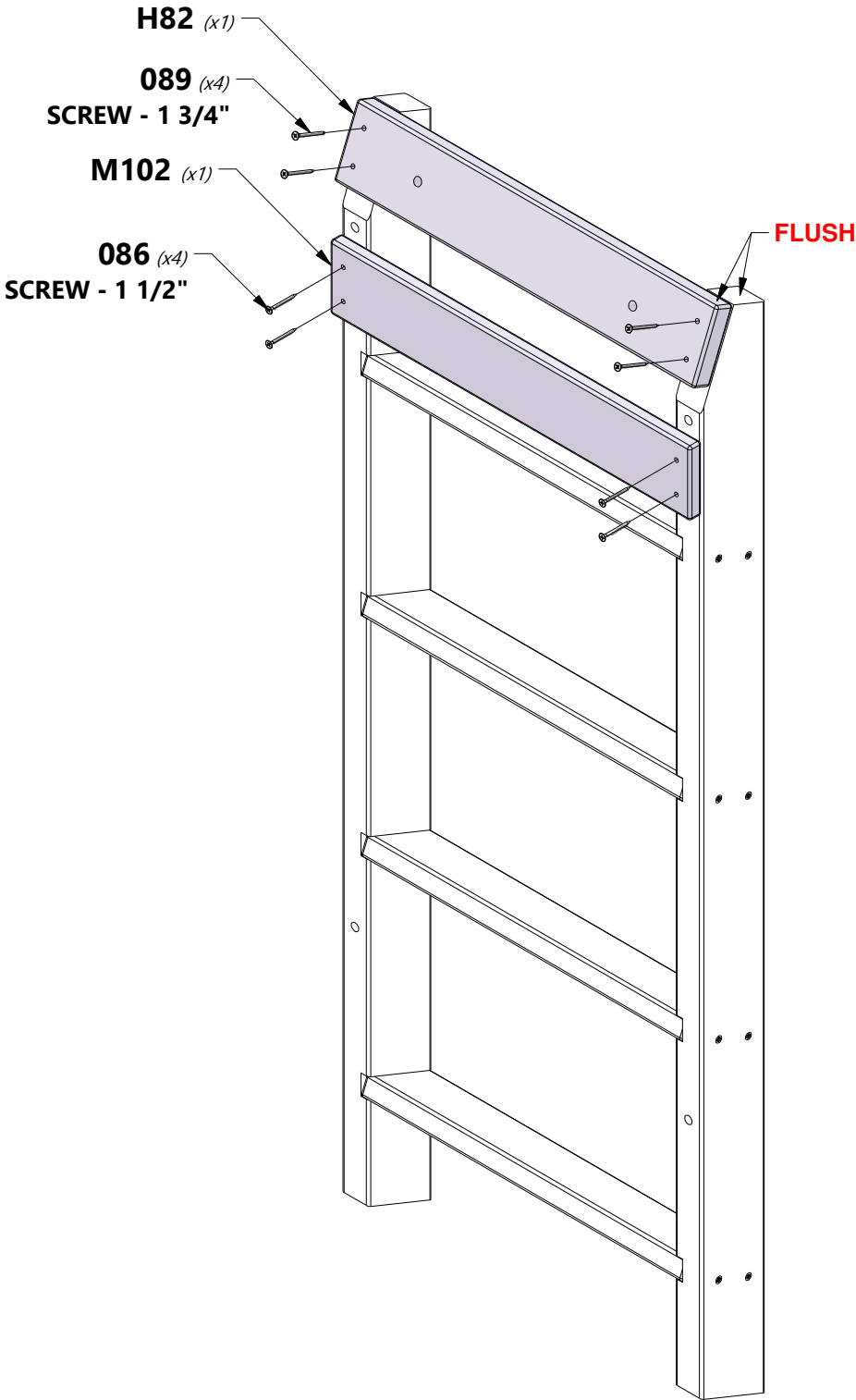

# STEP 4 - LADDER ASSEMBLY

QTY	PART NUMBER	DESCRIPTION
4	H100503	BOLT WH 5/16x3-1/2 BLK
4	H100379	T-NUT 5/16 BLK



- INSERT T-NUTS FIRST

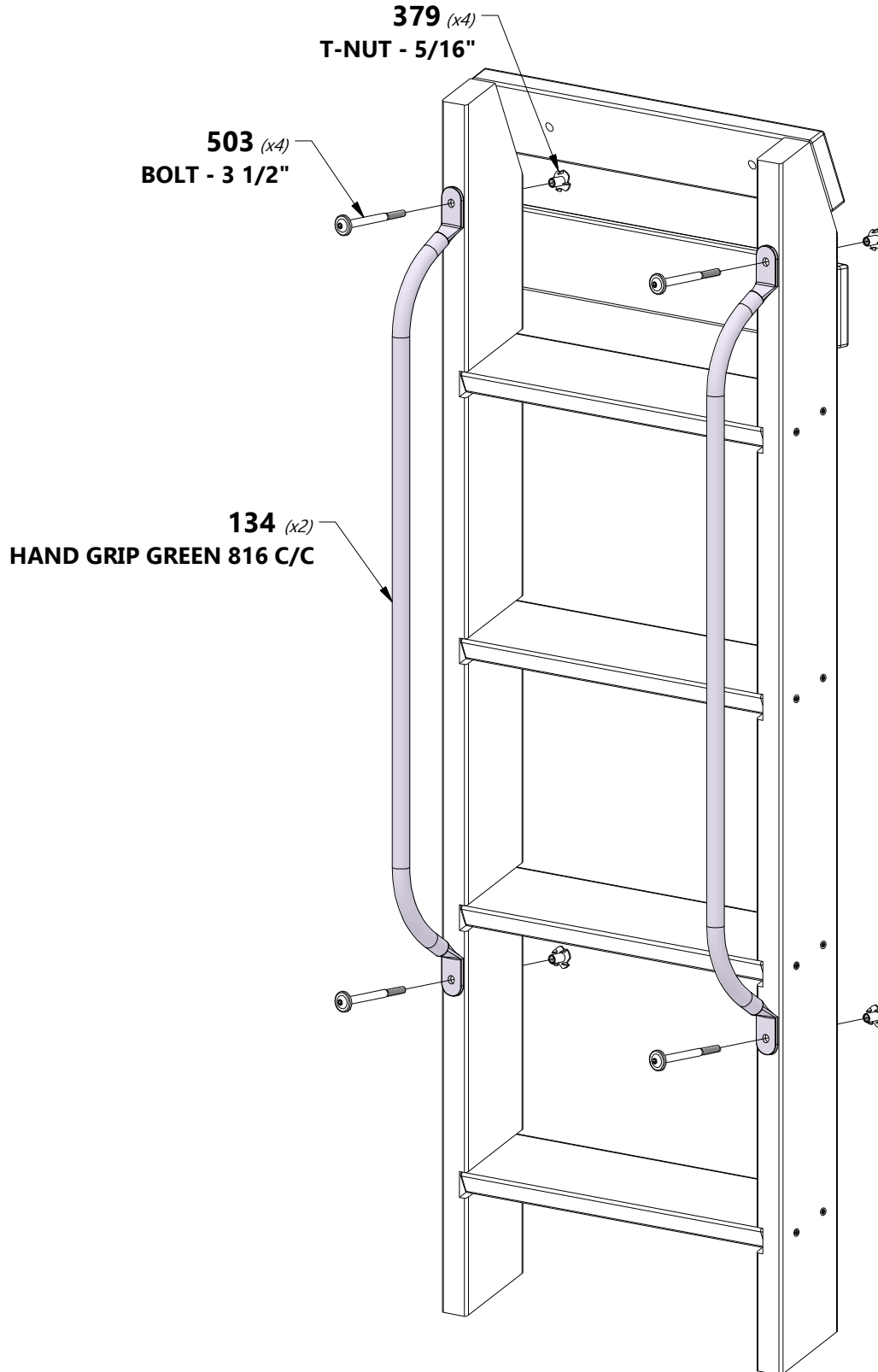

# STEP 1 - BAY WINDOW ASSEMBLY

QTY	PART NUMBER	DESCRIPTION
8	H100088	SCREW PFH 8x1-1/8"

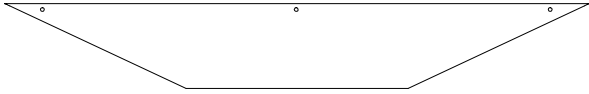

**L6 BAY WINDOW HEADER - W4L14568**  
(x2) 5/8"x4 3/8"x30 1/2" (16x112x774)



**N4 BAY WINDOW BOARD - W4L14605**  
(x2) 5/8"x2 3/8"x13 1/8" (16x60x332)



**N5 BAY WINDOW BOARD - W4L14606**  
(x2) 5/8"x2 3/8"x6 1/4" (16x60x158)

**- ALIGN PILOT HOLES**

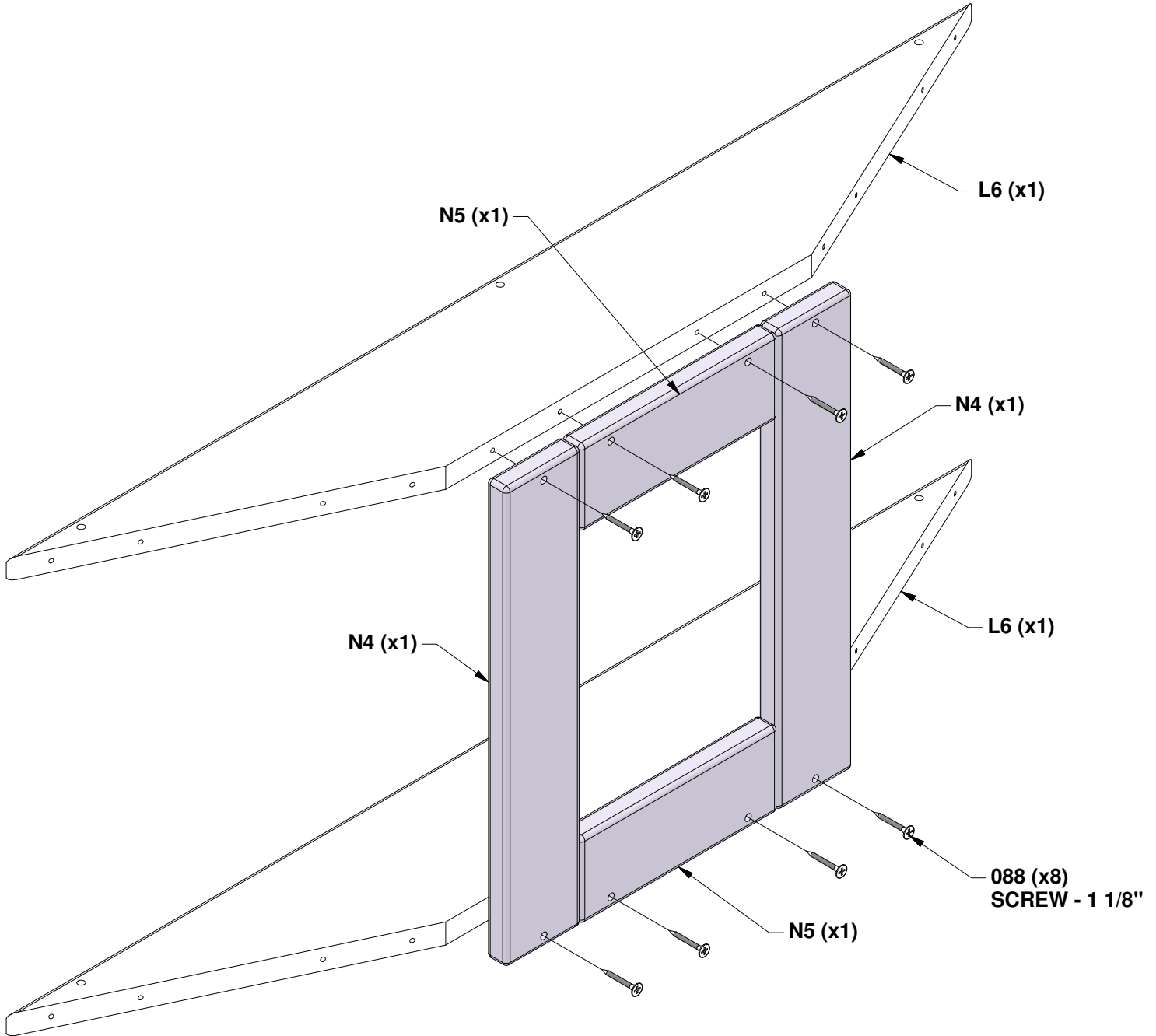

# STEP 2 - BAY WINDOW ASSEMBLY

QTY	PART NUMBER	DESCRIPTION
2	H100085	SCREW PFH 8x1
6	H100088	SCREW PFH 8x1-1/8"



**N4 BAY WINDOW BOARD - W4L14605**  
(x2) 5/8"x2 3/8"x13 1/8" (16x60x332)



**N5 BAY WINDOW BOARD - W4L14606**  
(x2) 5/8"x2 3/8"x6 1/4" (16x60x158)

## - ALIGN PILOT HOLES

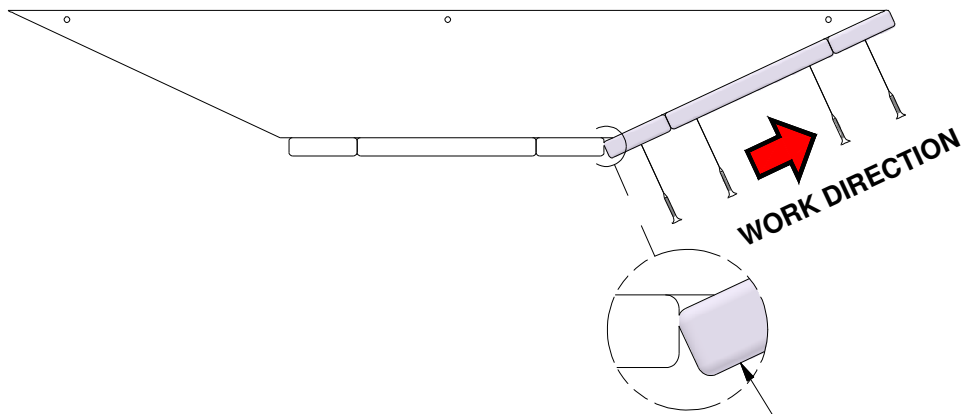
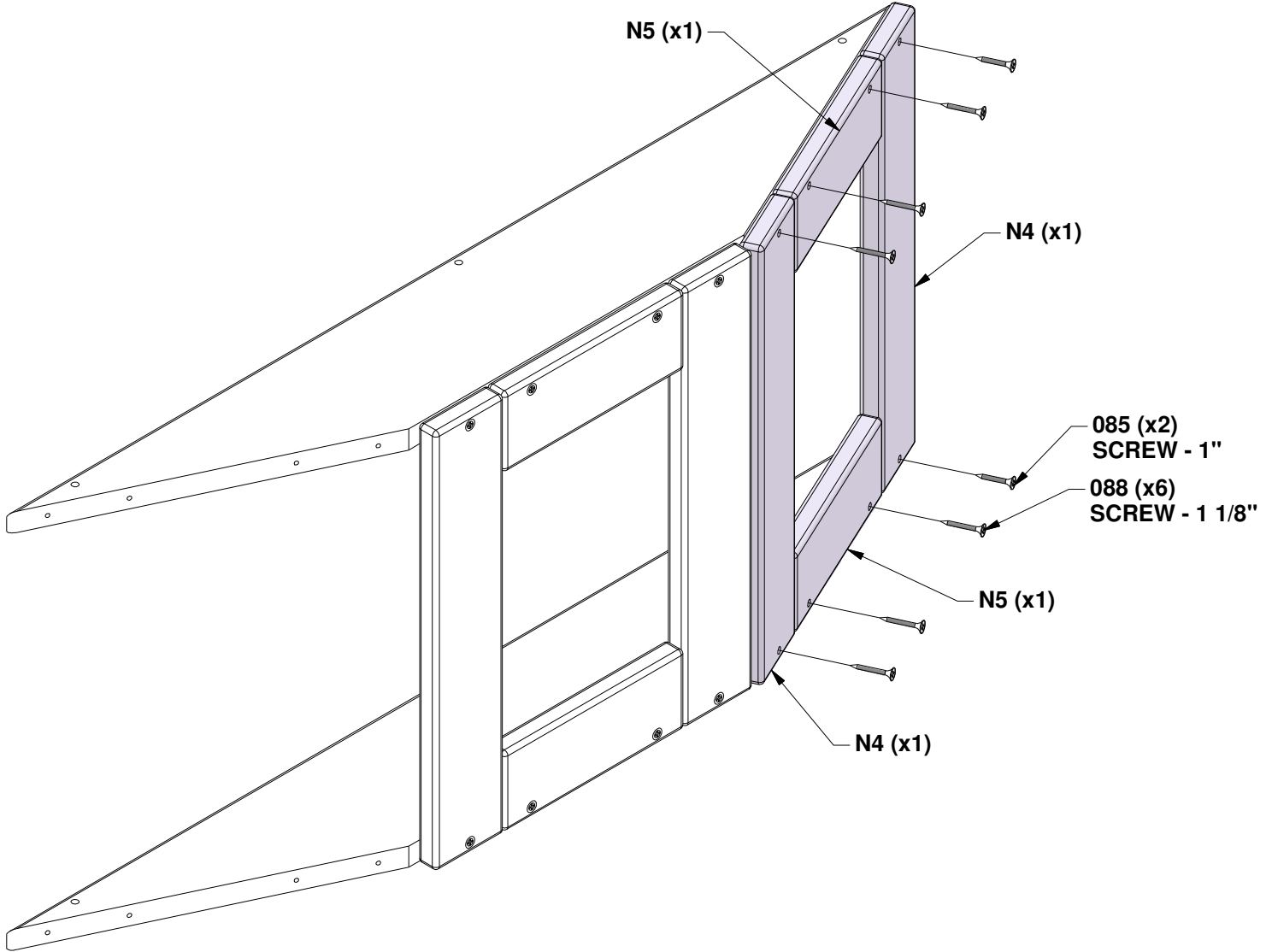

**START BY PLACING THE 'N4' BOARD FIRST, AS SHOWN.**

# STEP 3 - BAY WINDOW ASSEMBLY

QTY	PART NUMBER	DESCRIPTION
2	H100085	SCREW PFH 8x1
6	H100088	SCREW PFH 8x1-1/8"

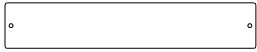

**N4 BAY WINDOW BOARD - W4L14605**  
 (x2) 5/8"x2 3/8"x13 1/8" (16x60x332)



**N5 BAY WINDOW BOARD - W4L14606**  
 (x2) 5/8"x2 3/8"x6 1/4" (16x60x158)

## - ALIGN PILOT HOLES

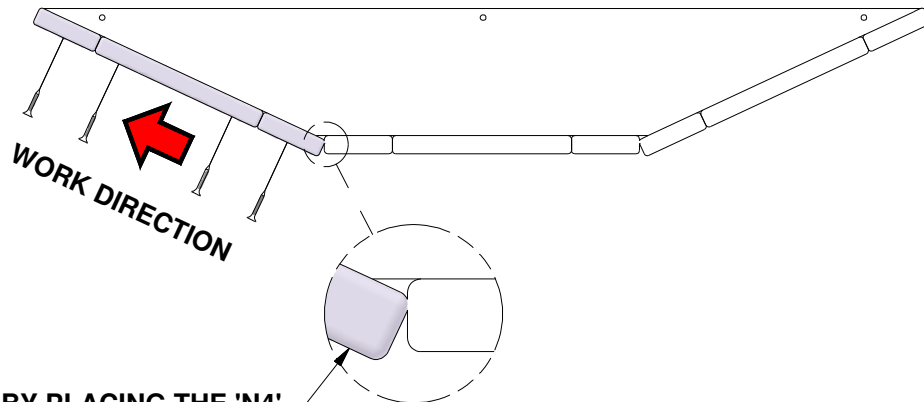
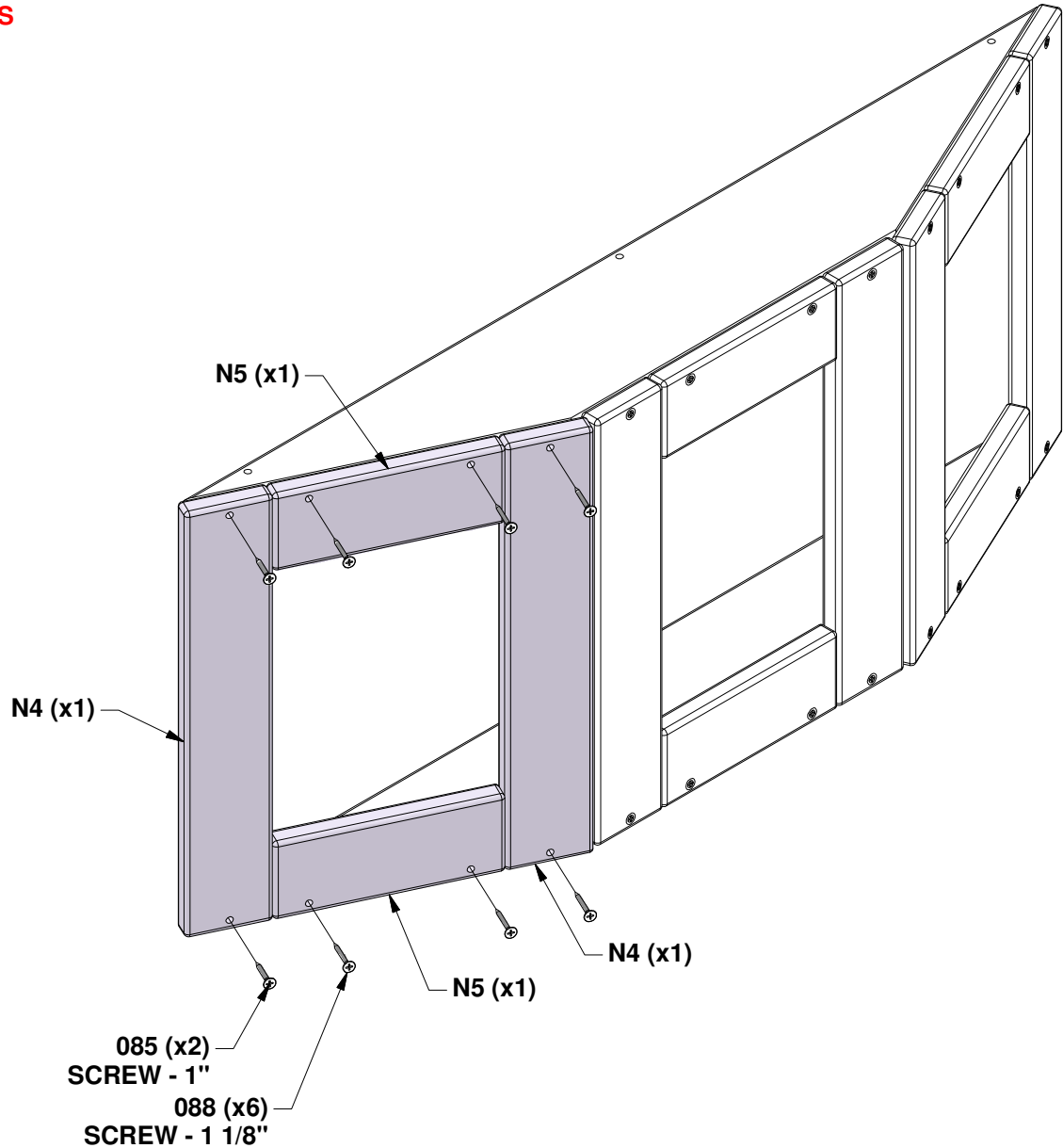

**START BY PLACING THE 'N4' BOARD FIRST, AS SHOWN.**

# STEP 4 - BAY WINDOW ASSEMBLY

QTY	PART NUMBER	DESCRIPTION
12	H100070	SCREW PWH 8x3/4

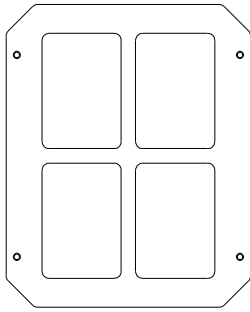

**A100014 PLASTIC WINDOW WHITE**  
(x3)

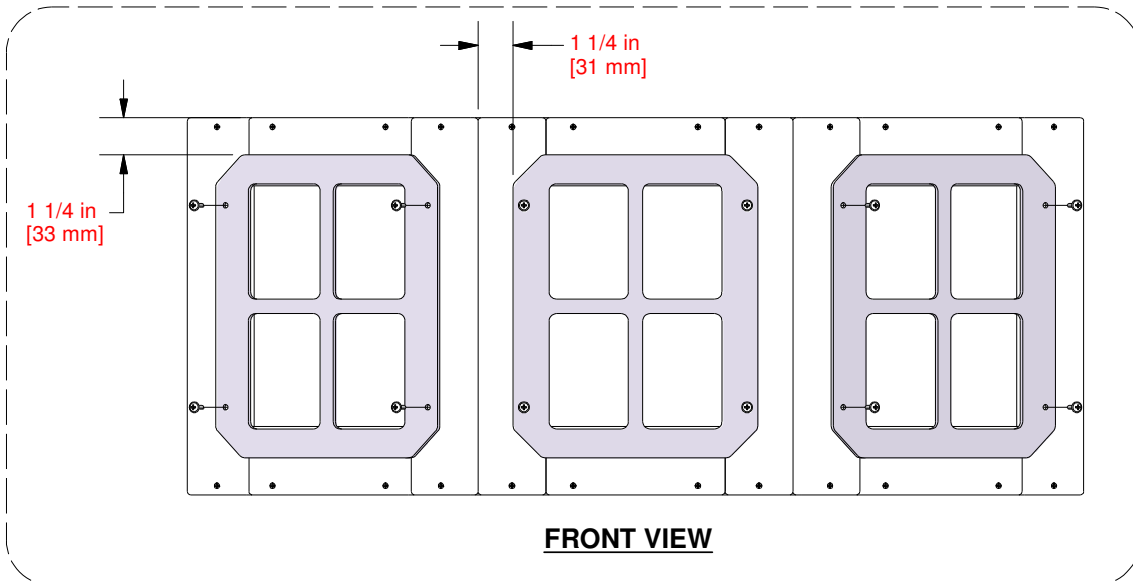
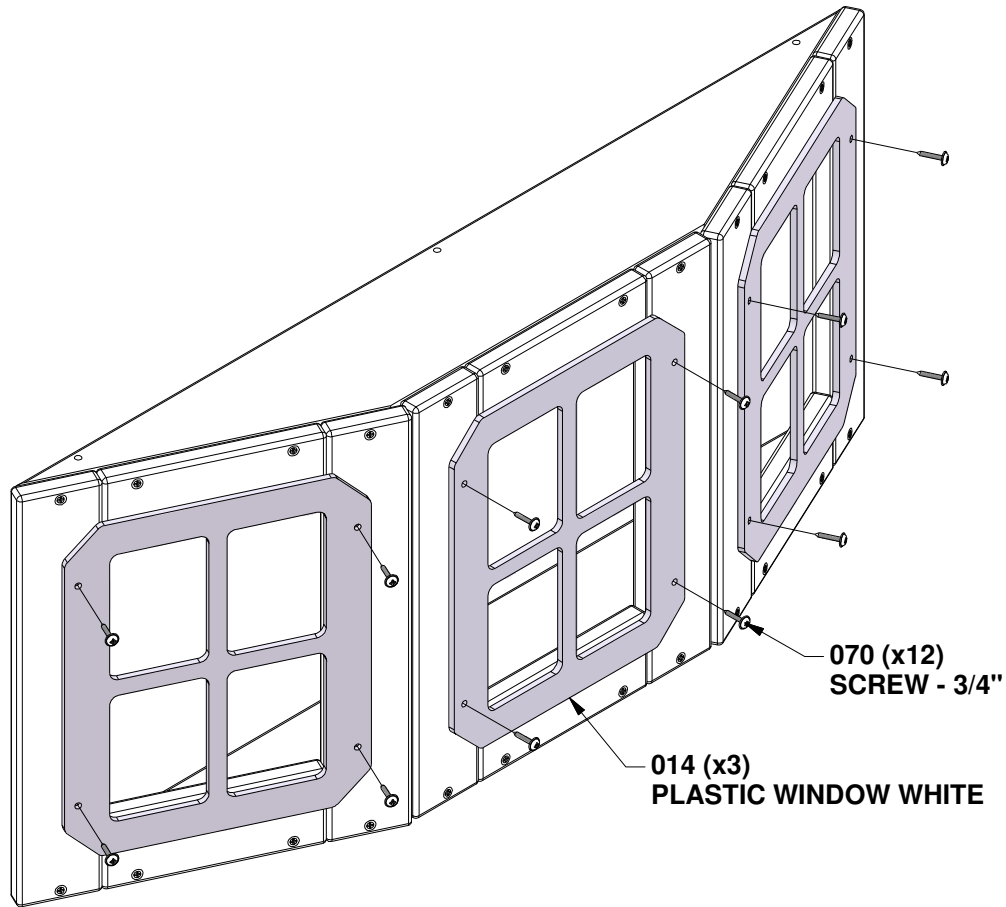

# STEP 1 - DOOR ASSEMBLY

QTY	PART NUMBER	DESCRIPTION
36	H100088	SCREW PFH 8x1-1/8"



**L8 DOOR BOARD - W4L14570**  
(x1) 5/8"x4 3/8"x35" (16x110x890)



**M23 DOOR BOARD - W4L14593**  
(x2) 5/8"x3 3/8"x35 3/4" (16x86x908)



**L7 DOOR BOARD - W4L22711**  
(x1) 5/8"x4 3/8"x35" (16x110x890)

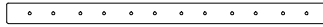

**O1 DOOR CLEAT - W4L14609**  
(x3) 5/8"x1 3/8"x21" (16x34x534)



**M25 DOOR BOARD - W4L14595**  
(x2) 5/8"x3 3/8"x6 1/4" (16x86x160)

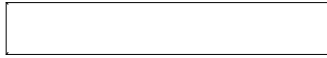

**M24 DOOR BOARD - W4L14594**  
(x2) 5/8"x3 3/8"x21 1/4" (16x86x540)

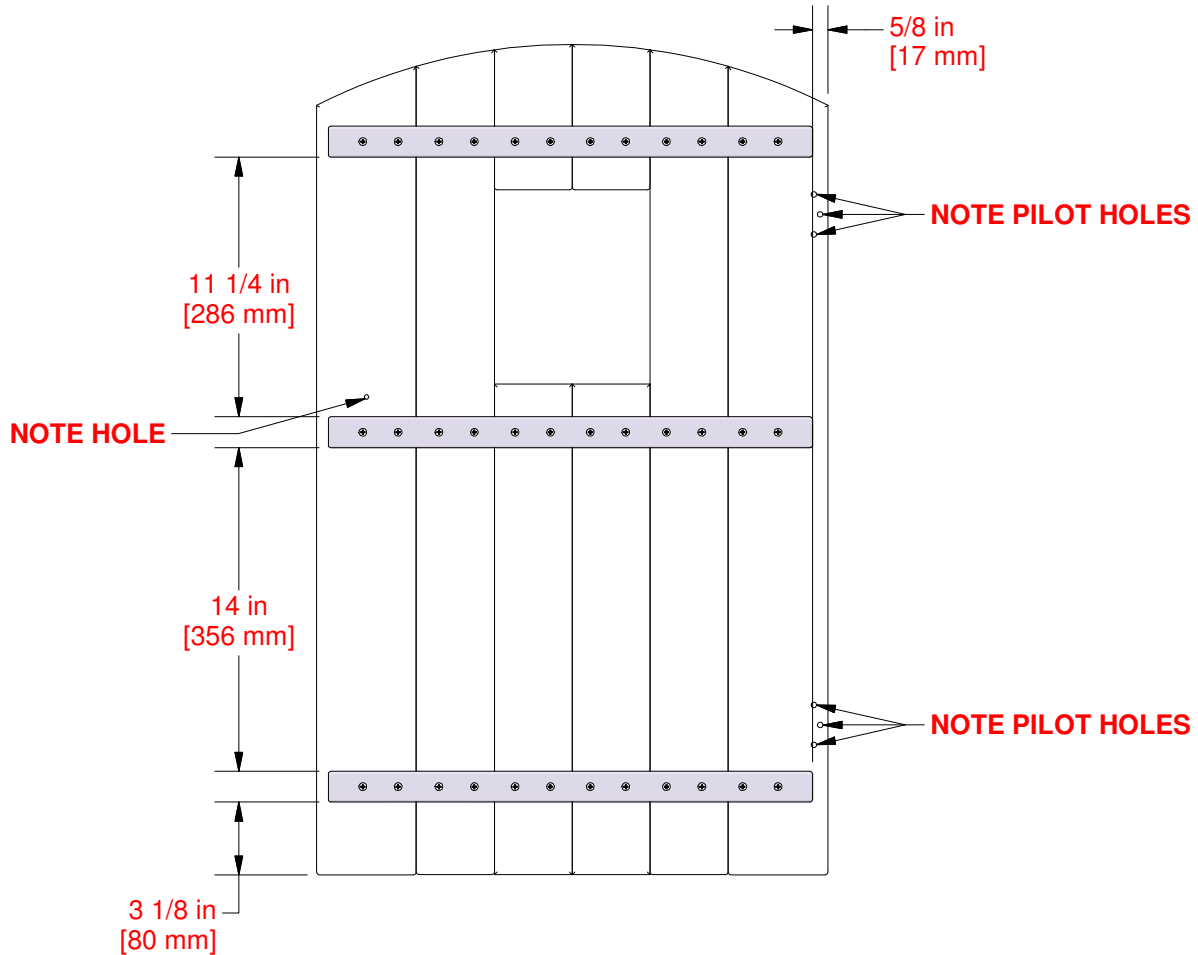
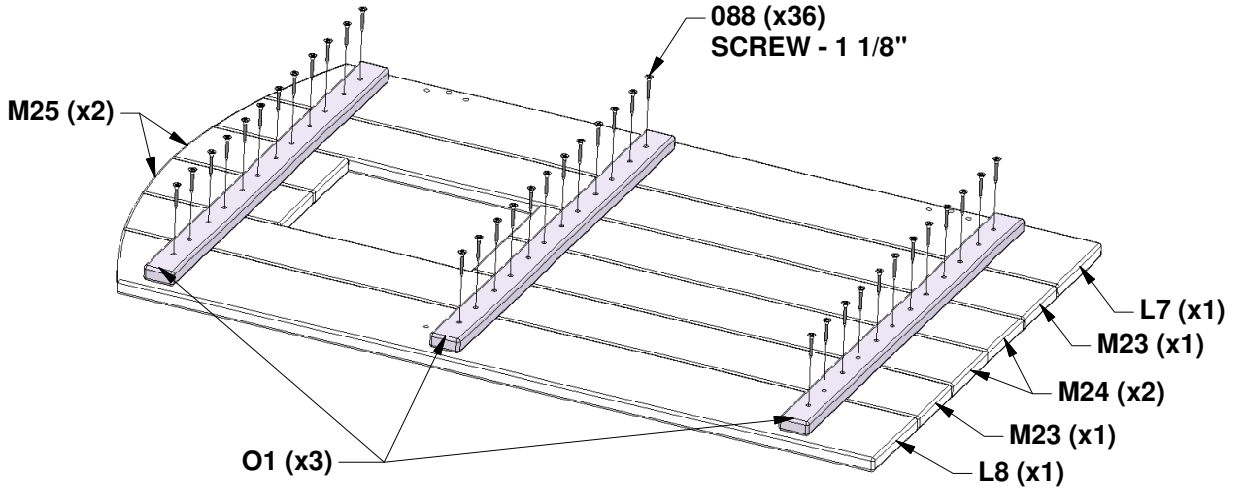

# STEP 2 - DOOR ASSEMBLY

QTY	PART NUMBER	DESCRIPTION
4	H100070	SCREW PWH 8x3/4

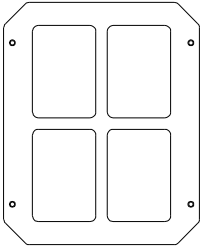

A100014 PLASTIC WINDOW WHITE  
(x1)

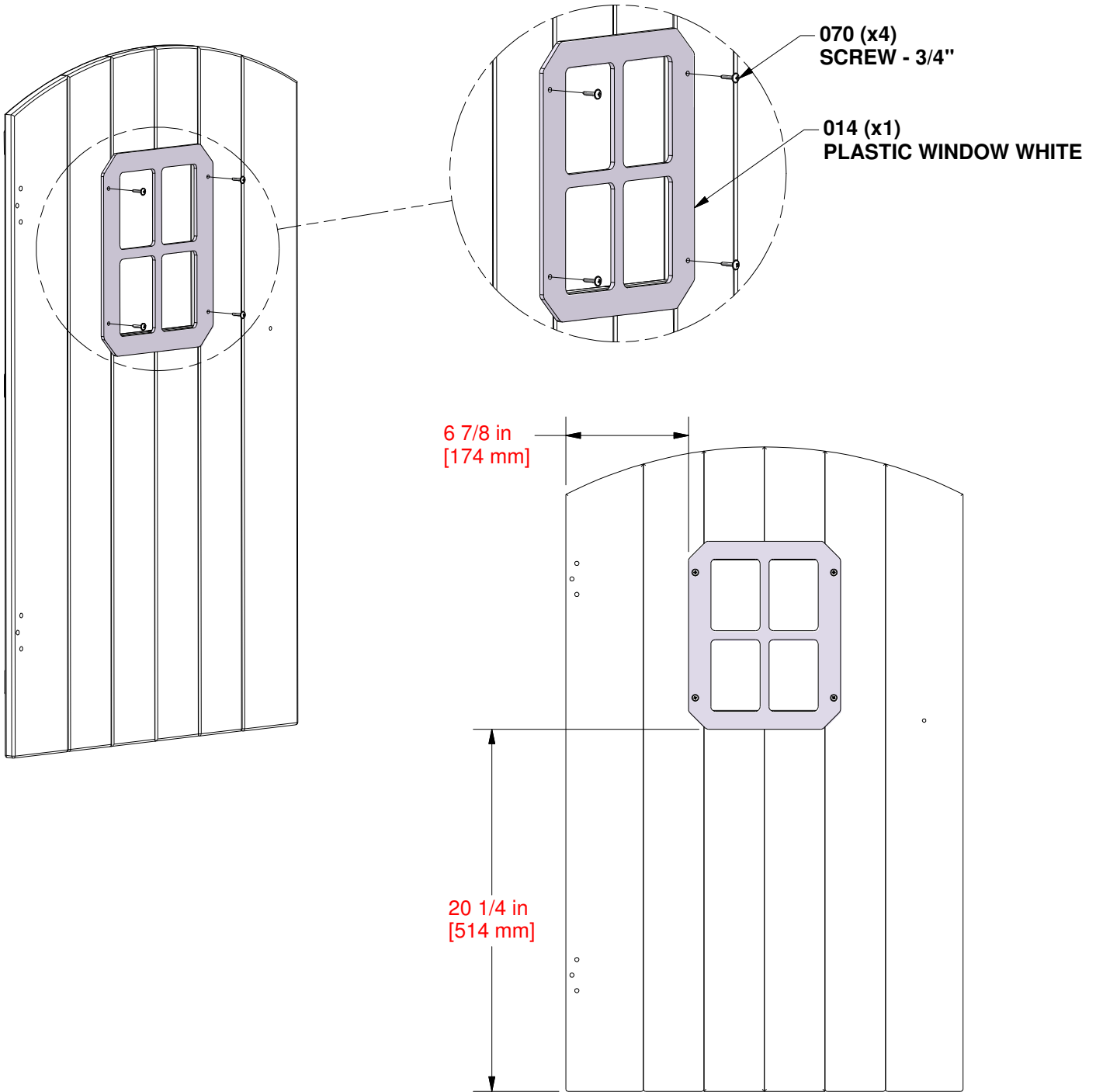

# STEP 3 - DOOR ASSEMBLY

QTY	PART NUMBER	DESCRIPTION
1	H100087	SCREW PFH 8x1-1/4"
6	H101401	SCREW POH-MS 8/32x1/2 BLK
6	H101272	NUT BARREL PPH 8x32 BLK

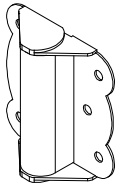

**A4M00624 HINGE (DOOR, SPRING LOADED)**  
(x2)

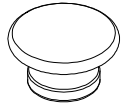

**A6P00122 KNOB - LT BROWN**  
(x1)

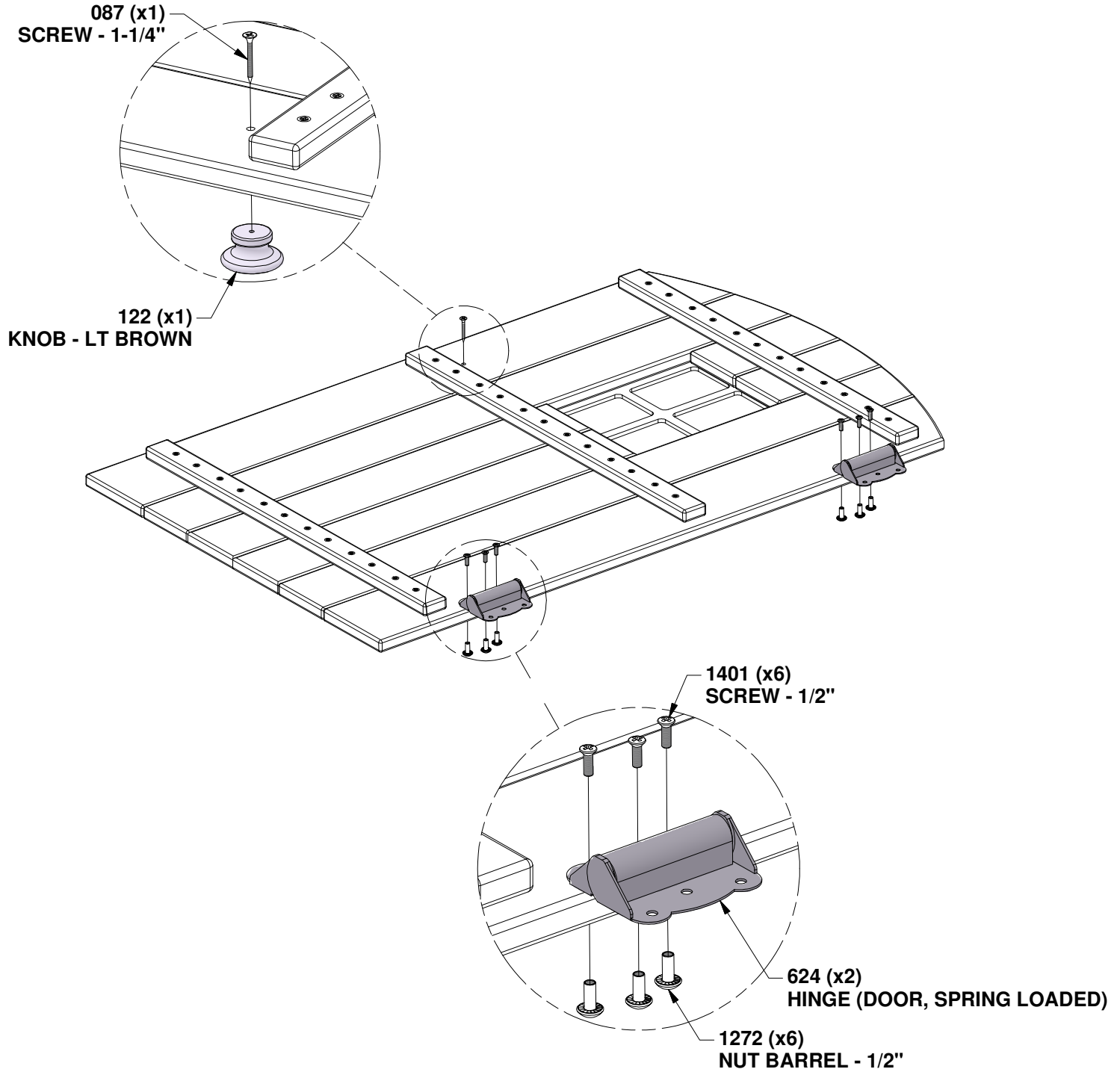

# STEP 1 - MONKEY BAR ASSEMBLY

QTY	PART NUMBER	DESCRIPTION
2	H100192	NUT BARREL WH 5/16x7/8 BLK
2	H100198	WASHER LOCK EXT 8x19 BLK
3	H100379	T-NUT 5/16 BLK
3	H100407	BOLT WH 5/16x1 1/2 BLK
2	H100468	BOLT WH 5/16x1 BLK

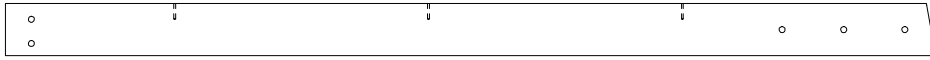

**E71 MONKEY BAR RAIL - W4L22703**  
(x1) 1 3/8"x3 3/8"x60 5/8" (36x86x1539)

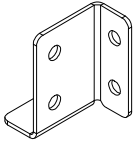

**A4M05884 SADDLE BRACKET**  
(x1) - LEFT

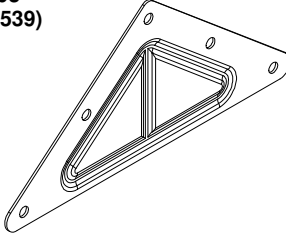

**A100294 TRIANGLE PLATE**  
(x1) 100° 5 HOLE

## - INSTALL T-NUTS IN WOOD FIRST

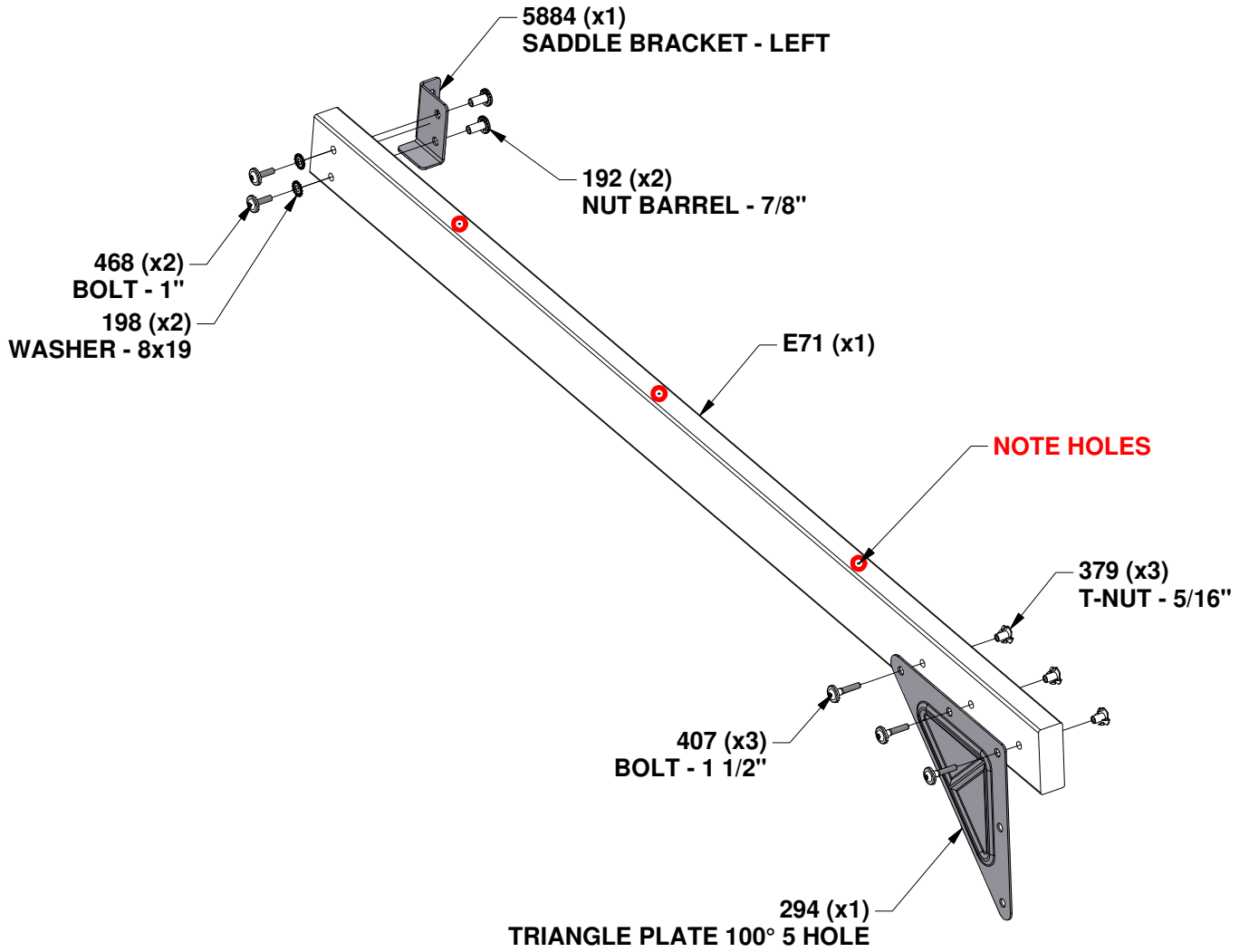

# STEP 2 - MONKEY BAR ASSEMBLY

QTY	PART NUMBER	DESCRIPTION
2	H100192	NUT BARREL WH 5/16x7/8 BLK
2	H100198	WASHER LOCK EXT 8x19 BLK
3	H100379	T-NUT 5/16 BLK
3	H100407	BOLT WH 5/16x1 1/2 BLK
2	H100468	BOLT WH 5/16x1 BLK



**E71 MONKEY BAR RAIL - W4L22703**  
(x1) 1 3/8"x3 3/8"x60 5/8" (36x86x1539)

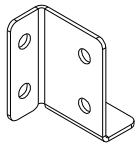

**A4M05883 SADDLE BRACKET**  
(x1) - RIGHT

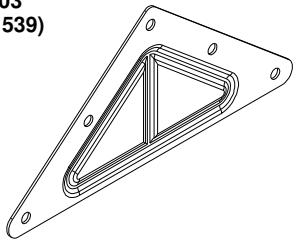

**A100294 TRIANGLE PLATE**  
(x1) 100° 5 HOLE

## INSTALL T-NUTS IN WOOD FIRST

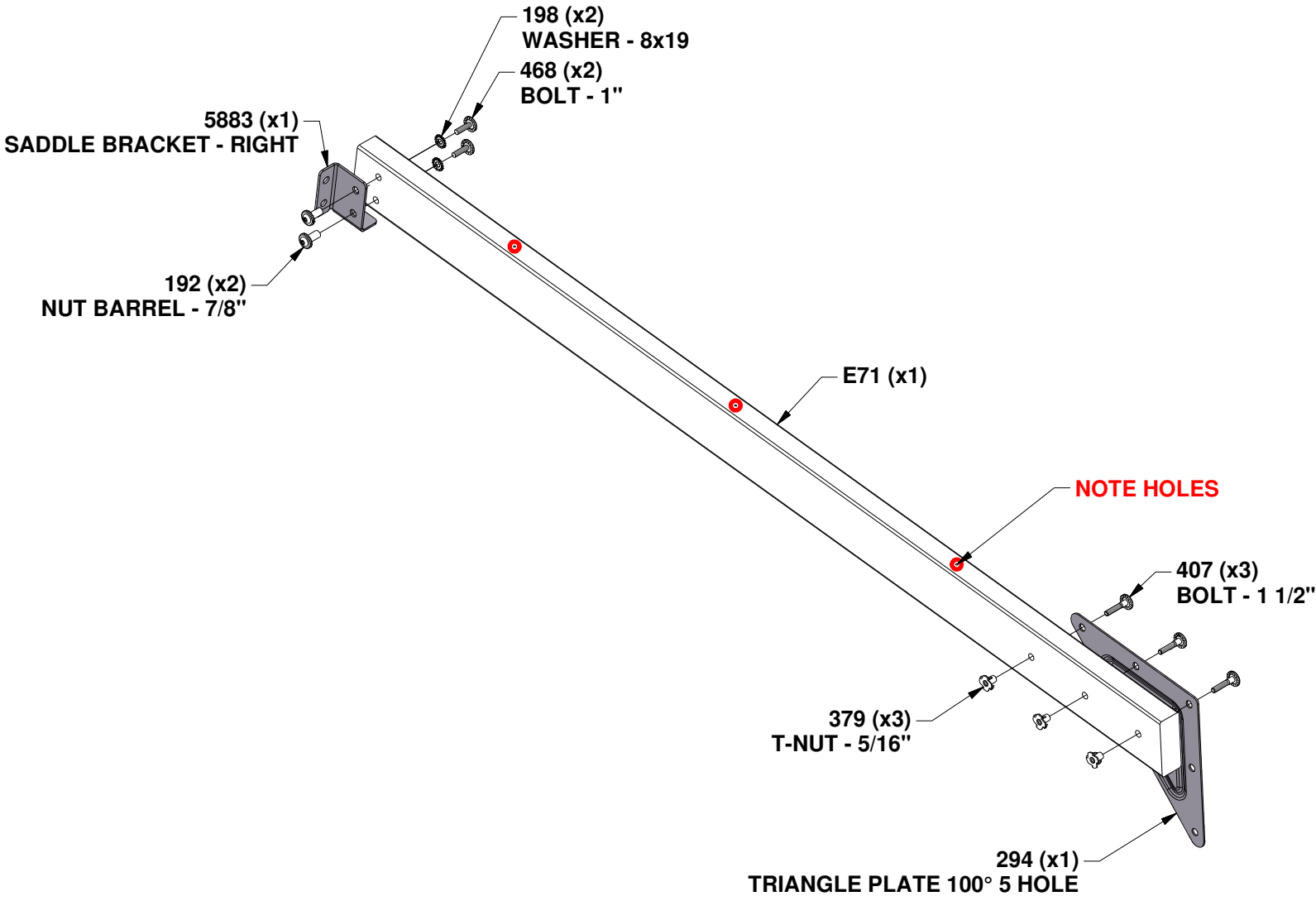

# STEP 3 - MONKEY BAR ASSEMBLY

QTY	PART NUMBER	DESCRIPTION
2	H100379	T-NUT 5/16 BLK
2	H100403	LAG SCREW WH 1/4x1-1/2 BLK
2	H100405	WASHER LOCK EXT 6x15 BLK
2	H100407	BOLT WH 5/16x1 1/2 BLK



**E6 MONKEY BAR UPRIGHT - W4L22700**  
 (x1) 1 3/8"x3 3/8"x71 3/8" (36x86x1812)

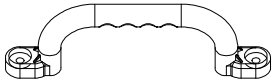

**A100028 HAND GRIP GREEN PLASTIC**  
 (x1)

**- INSTALL T-NUTS IN WOOD FIRST**

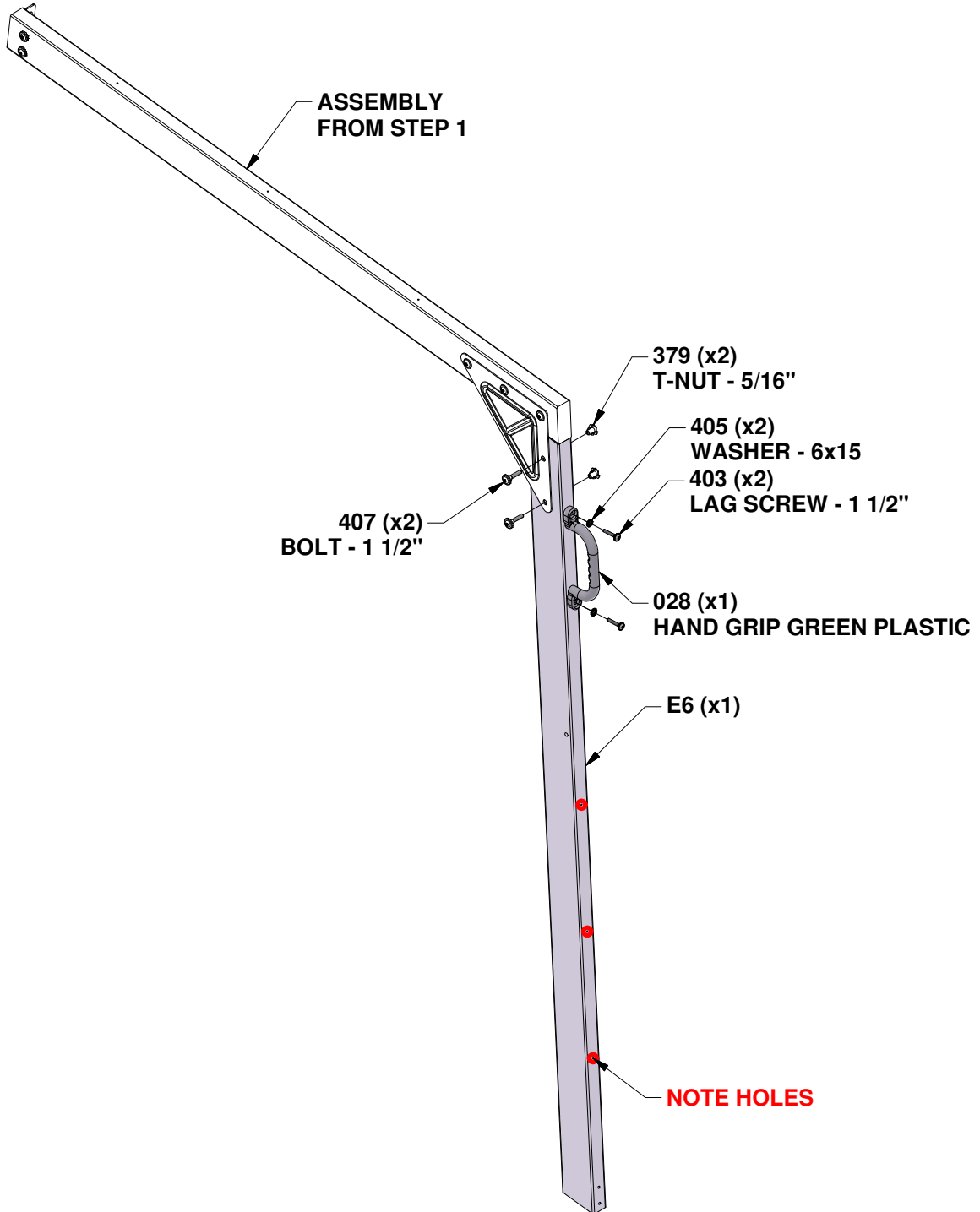

# STEP 4 - MONKEY BAR ASSEMBLY



**E6 MONKEY BAR UPRIGHT - W4L22700**  
 (x1) 1 3/8"x3 3/8"x71 3/8" (36x86x1812)

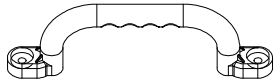

**A100028 HAND GRIP GREEN PLASTIC**  
 (x1)

QTY	PART NUMBER	DESCRIPTION
2	H100379	T-NUT 5/16 BLK
2	H100403	LAG SCREW WH 1/4x1-1/2 BLK
2	H100405	WASHER LOCK EXT 6x15 BLK
2	H100407	BOLT WH 5/16x1 1/2 BLK

## - INSTALL T-NUTS IN WOOD FIRST

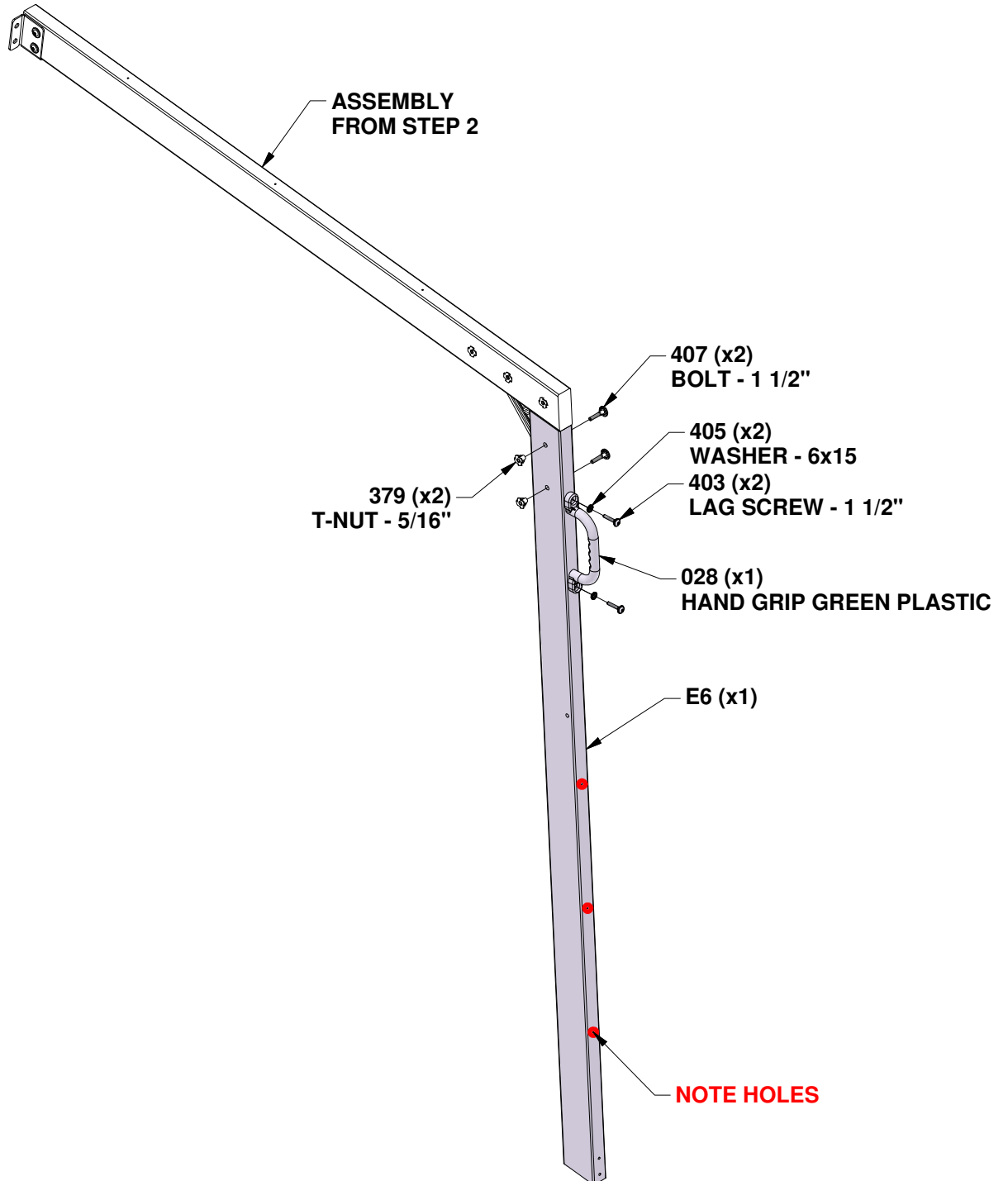

# STEP 5 - MONKEY BAR ASSEMBLY

QTY	PART NUMBER	DESCRIPTION
12	H100403	LAG SCREW WH 1/4x1-1/2 BLK

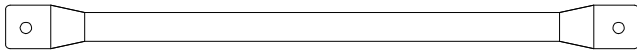

**A100045 METAL RUNG 559 GREEN**  
(x6)

## - ALIGN PILOT HOLES

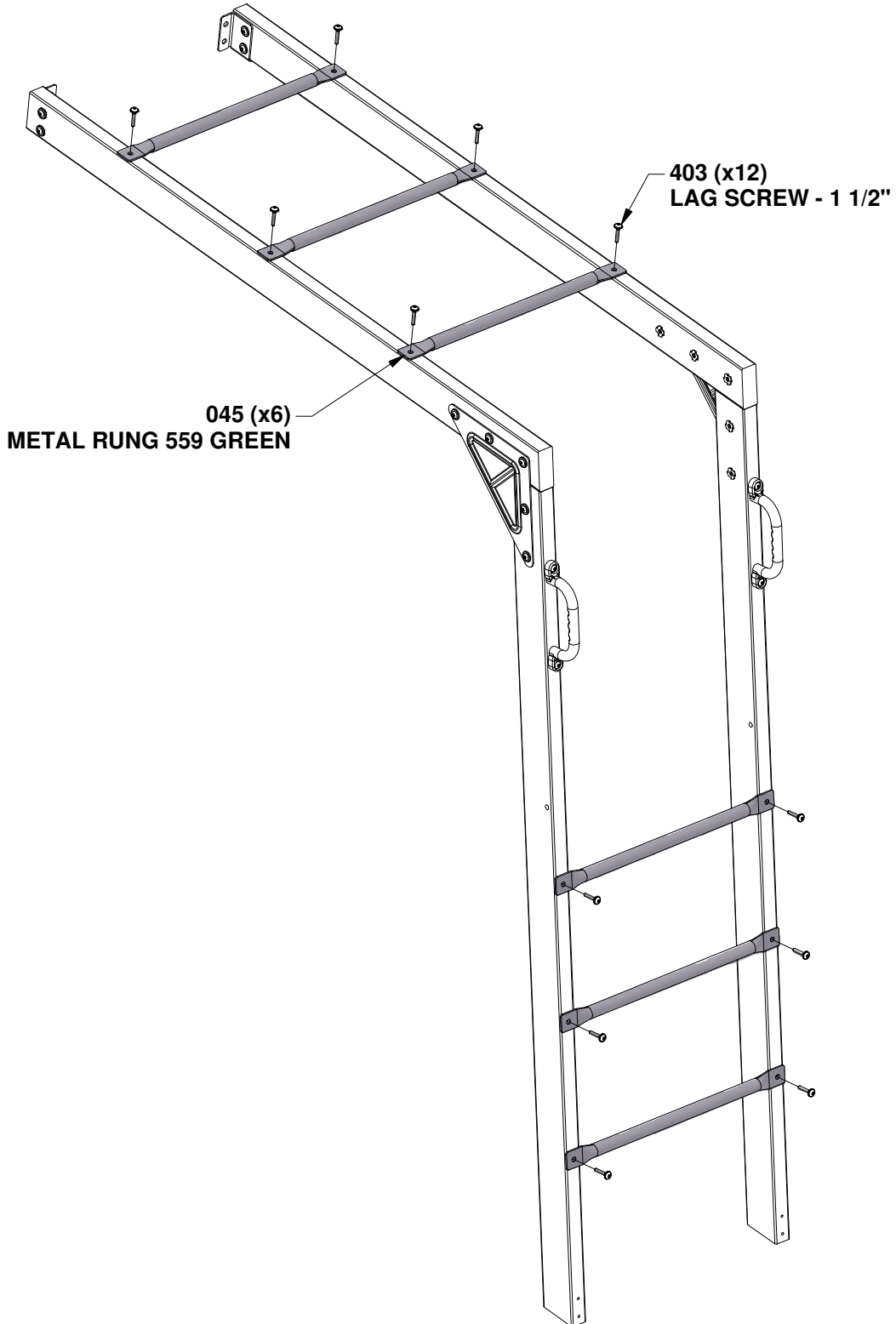

# STEP 6 - MONKEY BAR ASSEMBLY

QTY	PART NUMBER	DESCRIPTION
8	H100198	WASHER LOCK EXT 8x19 BLK
4	H100379	T-NUT 5/16 BLK
2	H100398	T-NUT 1/4 BLK
2	H100405	WASHER LOCK EXT 6x15 BLK
4	H100457	BOLT WH 5/16x2 BLK
4	H100458	LAG SCREW WH 5/16x2 BLK
2	H101376	BOLT WH 1/4x2 3/4 BLK



**HB4 MONKEY BAR BRACE - W4L22701**  
(x2) 1 1/8"x3"x52" (30x76x1320)



**HB5 MONKEY BAR GROUND BOARD - W4L22702**  
(x1) 1"x3"x70 3/4" (24x76x1798)

- INSTALL T-NUTS IN WOOD FIRST
- ALIGN PILOT HOLES

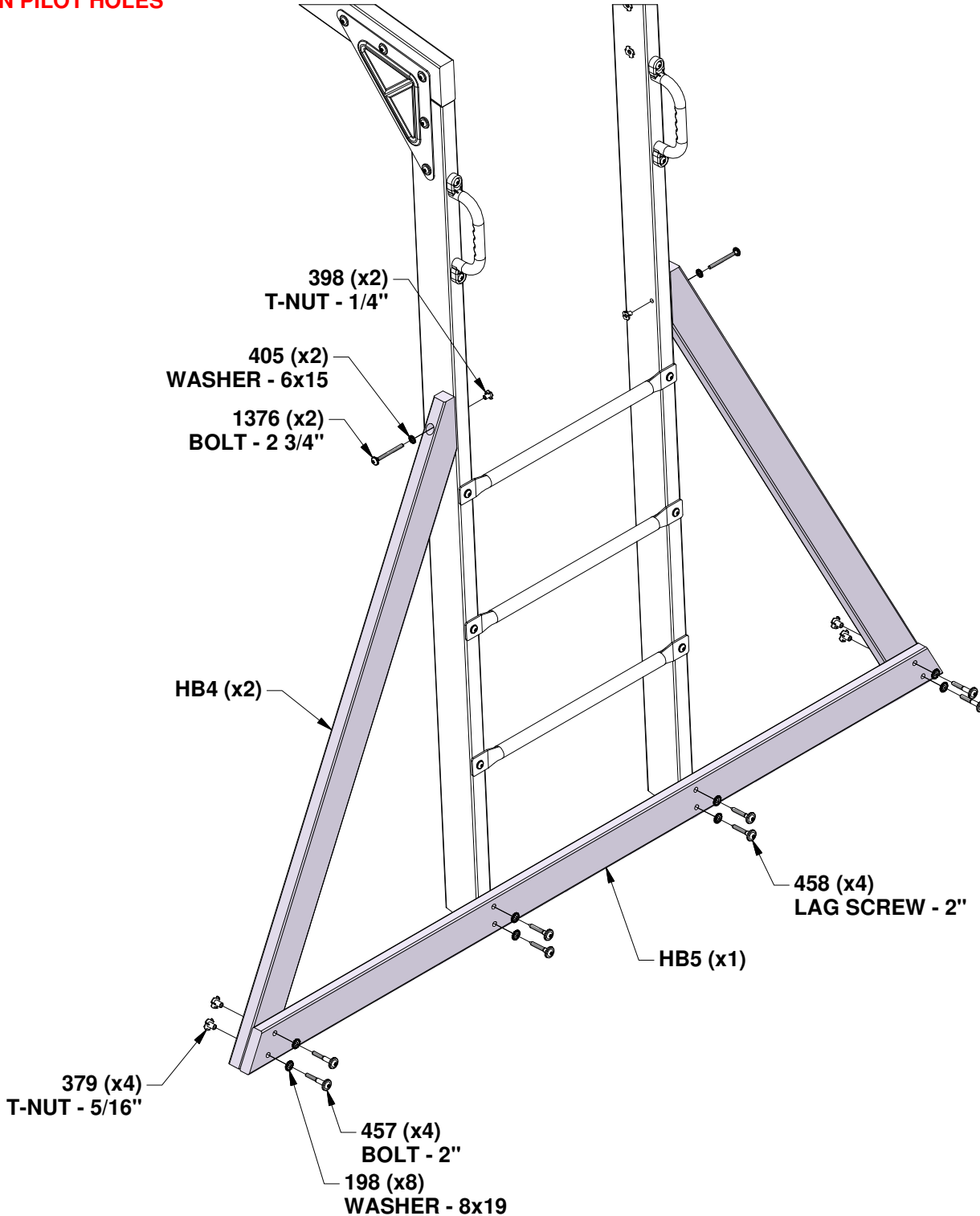

# STEP 1 - SWING BEAM ASSEMBLY

QTY	PART NUMBER	DESCRIPTION
5	H100192	NUT BARREL WH 5/16x7/8 BLK
5	H100416	BOLT WH 5/16x3 BLK

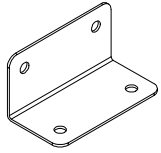

A100140 L BRACKET  
(x2) 66x66x127

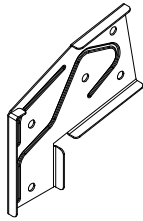

A100325 SWING BEAM  
EXTENSION  
BRACKET-LEFT  
(x1)

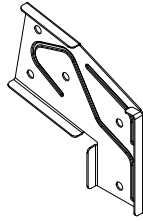

A100326 SWING BEAM  
EXTENSION  
BRACKET-RIGHT  
(x1)



A01 SWING BEAM EXTENDED - W4L21496  
(x1) 3 3/8"x5 1/4"x89 1/2" (86x134x2274)

## - ALIGN HOLES

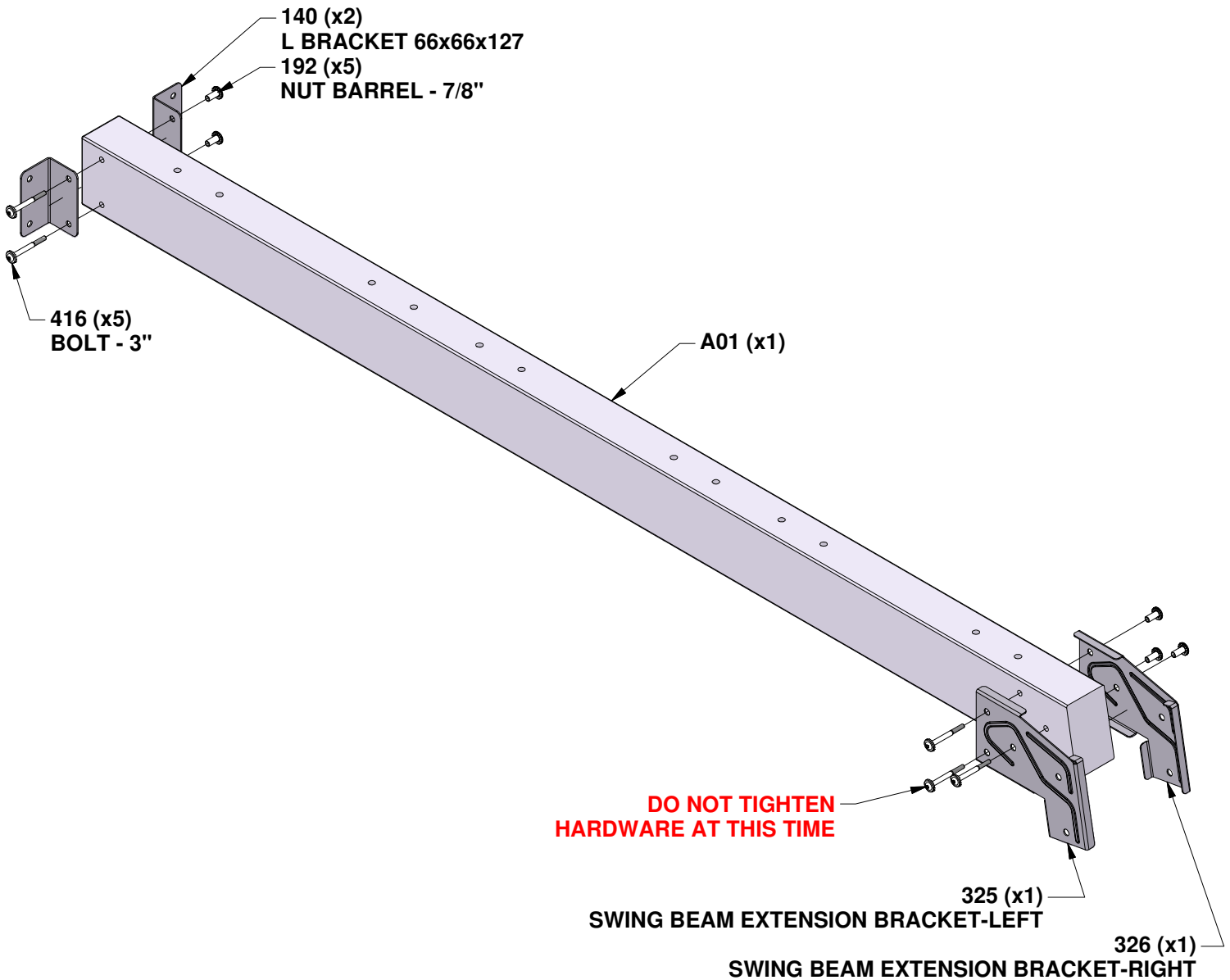

# STEP 2 - SWING BEAM ASSEMBLY

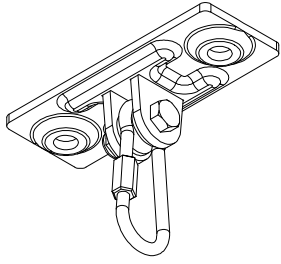

**A4M00505 SWING HANGER**  
(x6)



**A100164 BYD ID TAG (LARGE) AGES 3-10**  
(x1)

QTY	PART NUMBER	DESCRIPTION
4	H100070	SCREW PWH 8x3/4
12	H100073	T-NUT 3/8
12	H100102	WASHER FLAT 11x25
12	H100107	WASHER LOCK INT 10x18
12	H100654	BOLT HEX 3/8x5-1/2

## - INSTALL T-NUTS IN WOOD FIRST

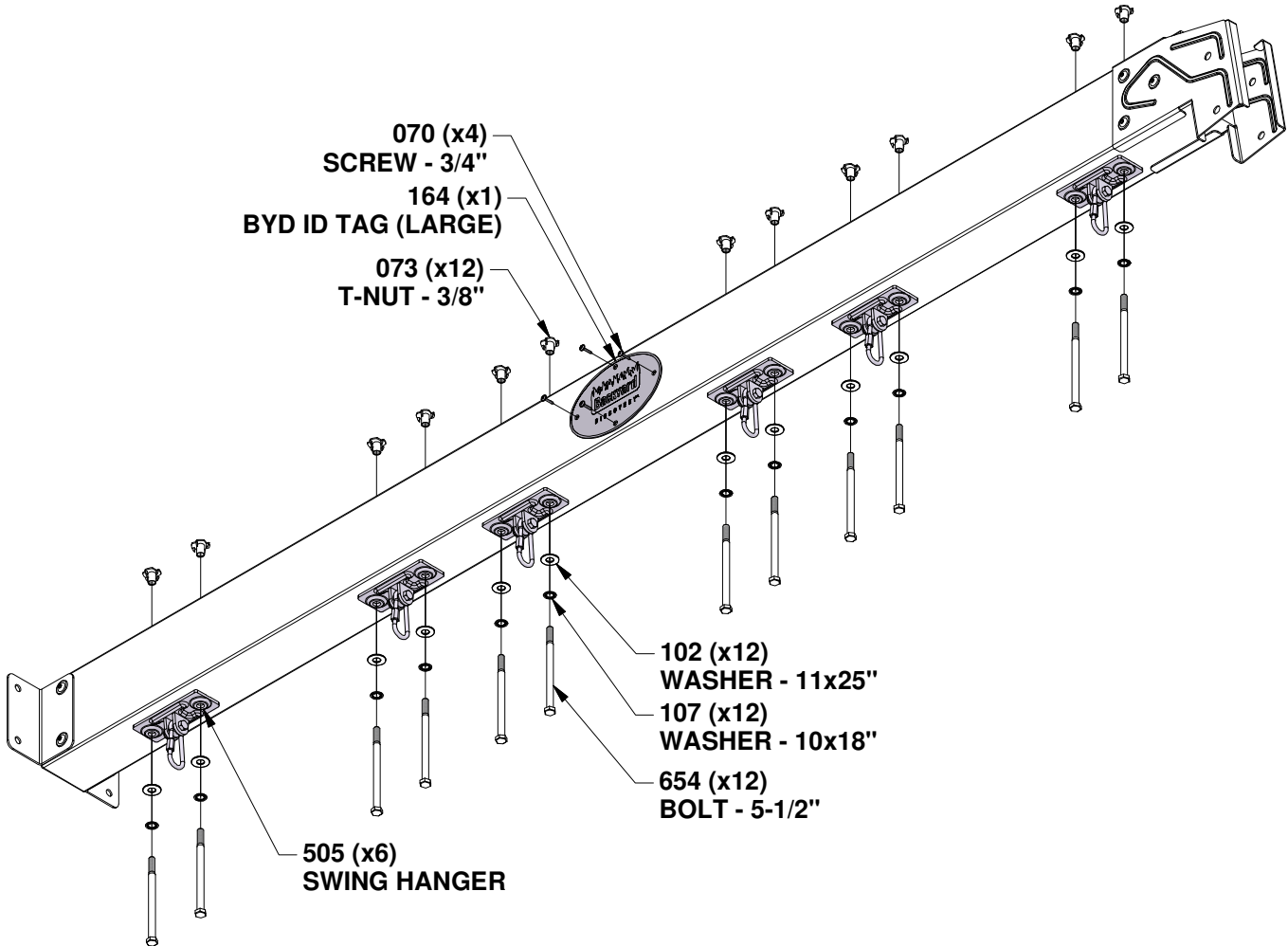

# STEP 3 - SWING BEAM ASSEMBLY

QTY	PART NUMBER	DESCRIPTION
6	H100379	T-NUT 5/16 BLK
4	H100407	BOLT WH 5/16x1 1/2 BLK
2	H100503	BOLT WH 5/16x3-1/2 BLK

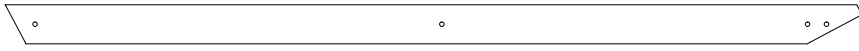

**E7 ANGLE BRACE - W4L22726**  
(x2) 1 3/8"x3 3/8"x74 3/8" (36x86x1890)



**SP01 SWING BEAM SUPPORT - W4L21497**  
(x1) 3 3/8"x3 3/8"x50 5/8" (86x86x1286)

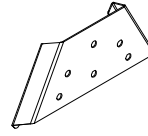

**A4M01169 A-FRAME BRACKET**  
(x1)

## - INSTALL T-NUTS IN WOOD FIRST

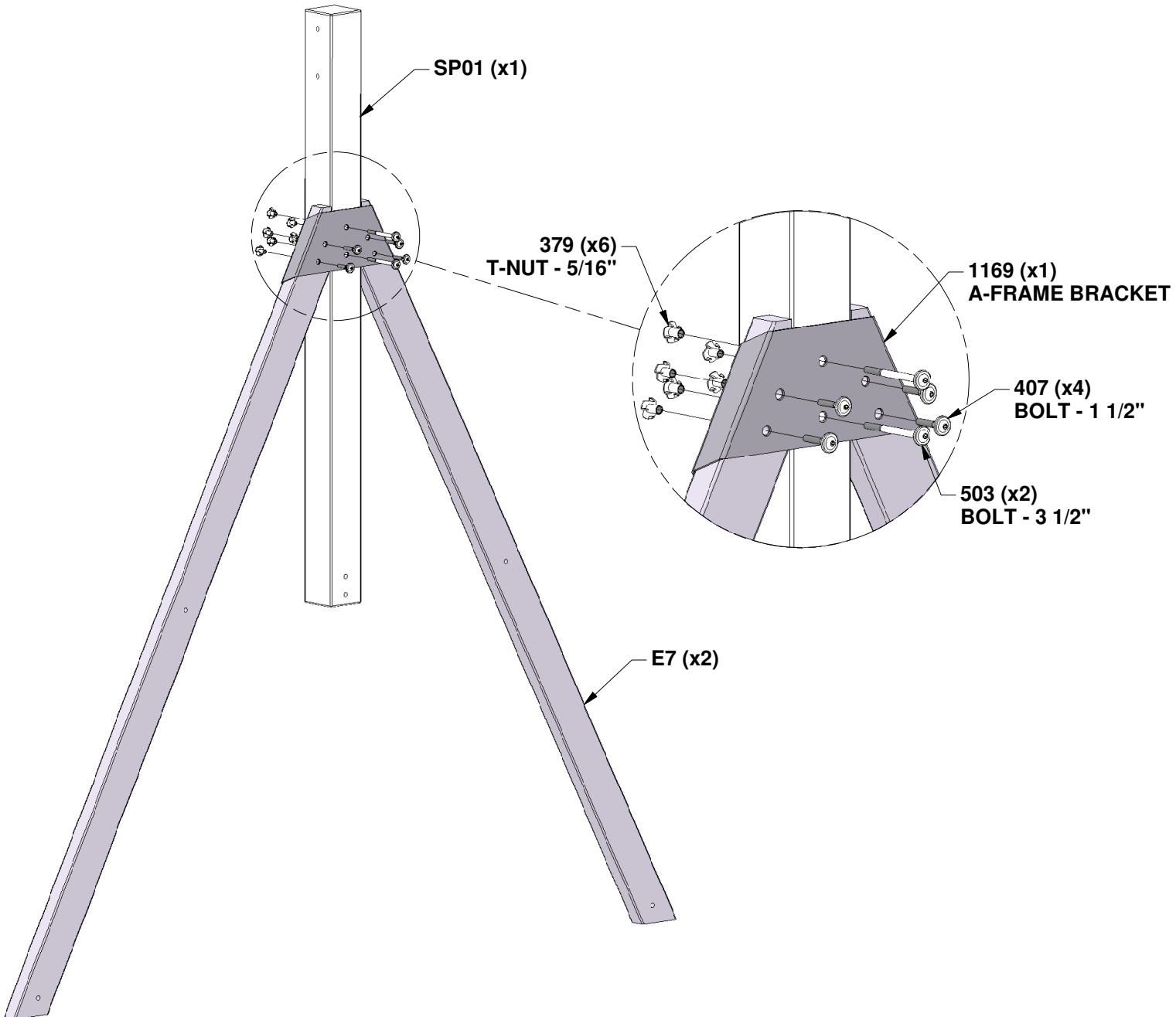

# STEP 4 - SWING BEAM ASSEMBLY

QTY	PART NUMBER	DESCRIPTION
6	H100198	WASHER LOCK EXT 8x19 BLK
4	H100194	BOLT WH 5/16x2-1/2 BLK
6	H100379	T-NUT 5/16 BLK
2	H100534	BOLT WH 5/16x4 1/2 BLK

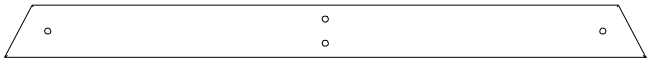

**OG01 END SUPPORT - W4L21476**  
(x1 1"x3 1/2"x42" (30x86x1061))

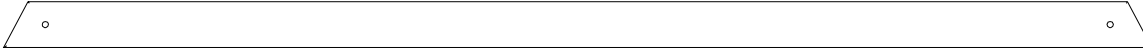

**OB01 GROUND BOARD - W4L21477**  
(x1 1 1/8"x3"x74 3/4" (30x76x1900))

**- INSTALL T-NUTS IN WOOD FIRST**

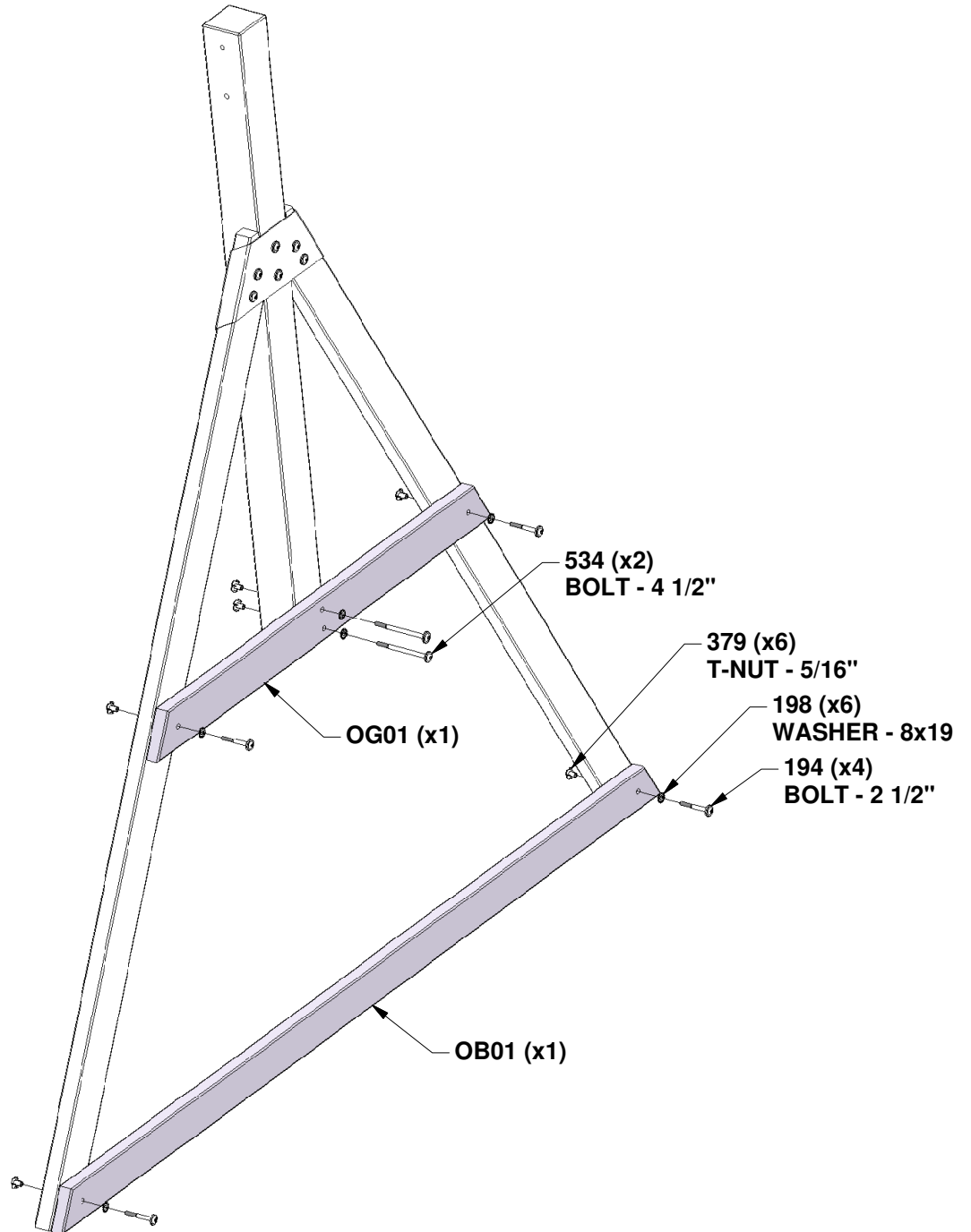

# STEP 5 - SWING BEAM ASSEMBLY

QTY	PART NUMBER	DESCRIPTION
2	H100192	NUT BARREL WH 5/16x7/8 BLK
2	H100416	BOLT WH 5/16x3 BLK

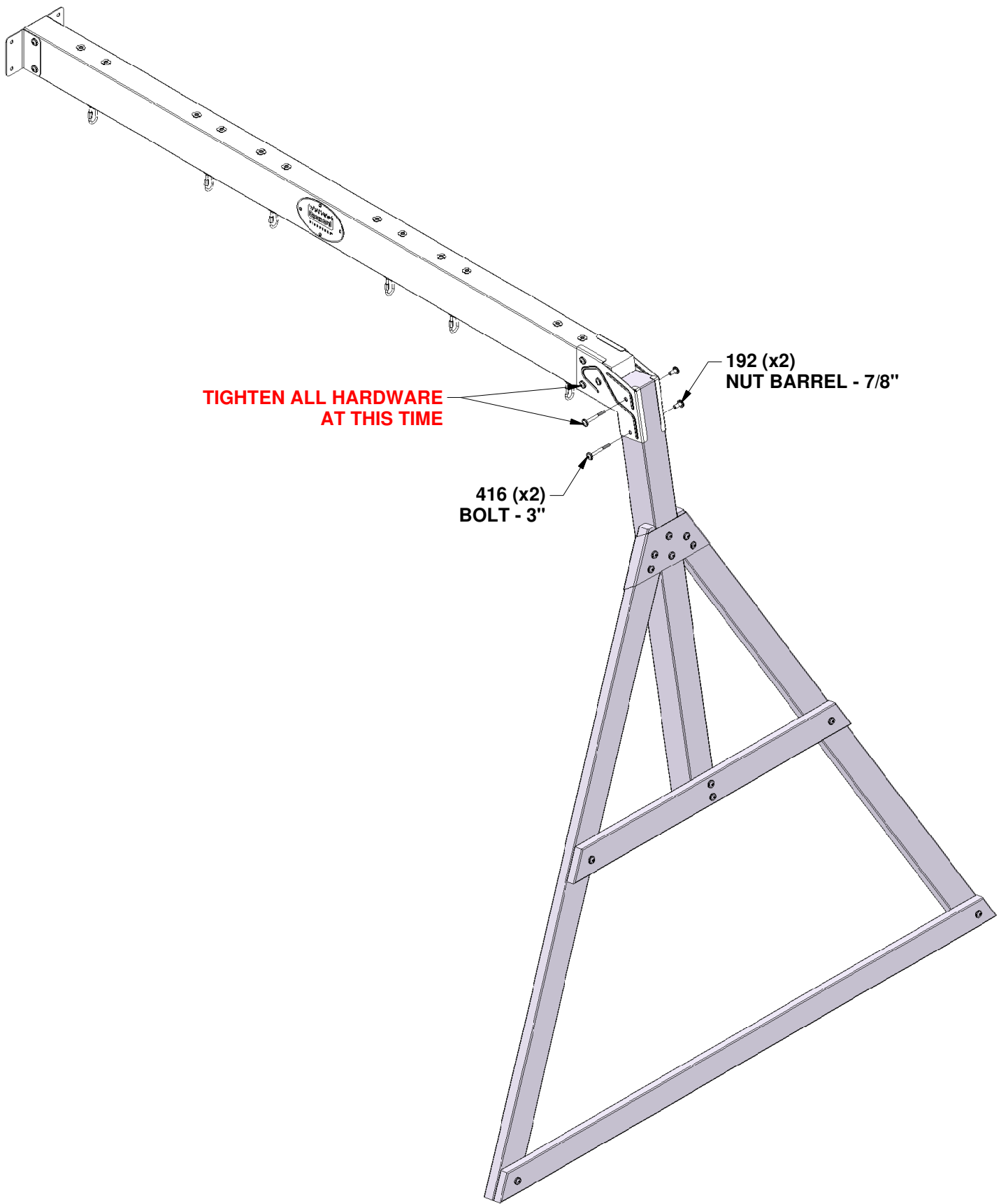

# STEP 1A - FORT ASSEMBLY

QTY	PART NUMBER	DESCRIPTION
14	H100198	WASHER LOCK EXT 8x19 BLK
12	H100205	BOLT WH 5/16x2-1/4 BLK
12	H100379	T-NUT 5/16 BLK
2	H100471	LAG SCREW WH 5/16x1-1/2 BLK

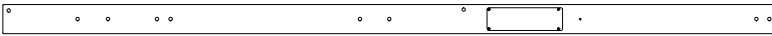

**E1** | UPRIGHT - W2A03132  
(x1) | 1 3/8"x3 3/8"x89 1/2" (36x86x2274)

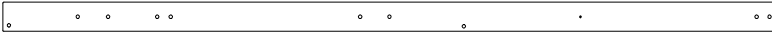

**E3** | UPRIGHT - W4L22704  
(x1) | 1 3/8"x3 3/8"x89 1/2" (36x86x2274)

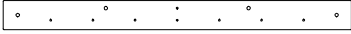

**H2** | FLOOR SUPPORT - W4L22676  
(x1) | 1"x3 3/8"x40 3/8" (24x86x1024)



**H6** | FLOOR SUPPORT - W4L22680  
(x1) | 1"x3 3/8"x40 3/8" (24x86x1024)

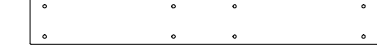

**OJ01** | SWING BEAM MOUNT - W4L22696  
(x1) | 1 1/8"x5 1/4"x40 3/8" (30x134x1024)



**Q1** | WALL RAIL - W4L22692  
(x1) | 1"x4 3/8"x40 3/8" (24x112x1024)

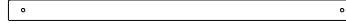

**N1** | SAFETY BOARD - W4L14602  
(x1) | 5/8"x2 3/8"x40 3/8" (16x60x1024)

- INSTALL T-NUTS IN WOOD FIRST
- ALIGN PILOT HOLES

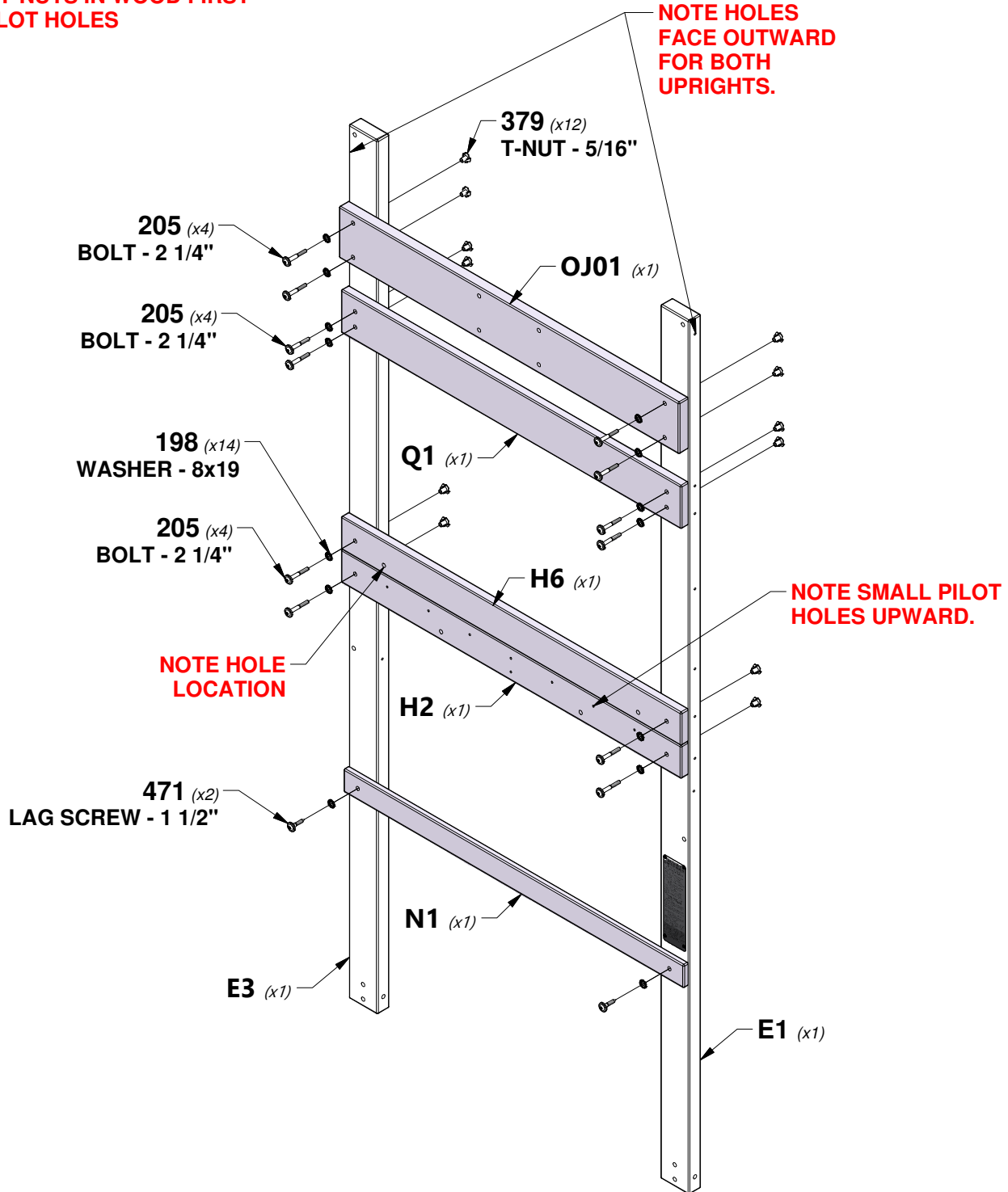

# STEP 1B - FORT ASSEMBLY

QTY	PART NUMBER	DESCRIPTION
8	H100198	WASHER LOCK EXT 8x19 BLK
4	H100205	BOLT WH 5/16x2-1/4 BLK
8	H100379	T-NUT 5/16 BLK
2	H100405	WASHER LOCK EXT 6x15 BLK
4	H100457	BOLT WH 5/16x2 BLK
2	H100487	LAG SCREW WH 1/4x2 BLK

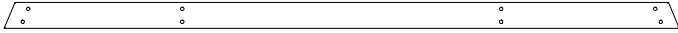

**HB1** | GROUND BOARD - W4L22671  
(x1) | 1"x3"x78 1/4" (24x76x1986)



**OG03** | ANGLE BRACE - W4L22674  
(x2) | 1 3/16"x3 3/8"x47" (30x86x1194)

- INSTALL T-NUTS IN WOOD FIRST
- ALIGN PILOT HOLES

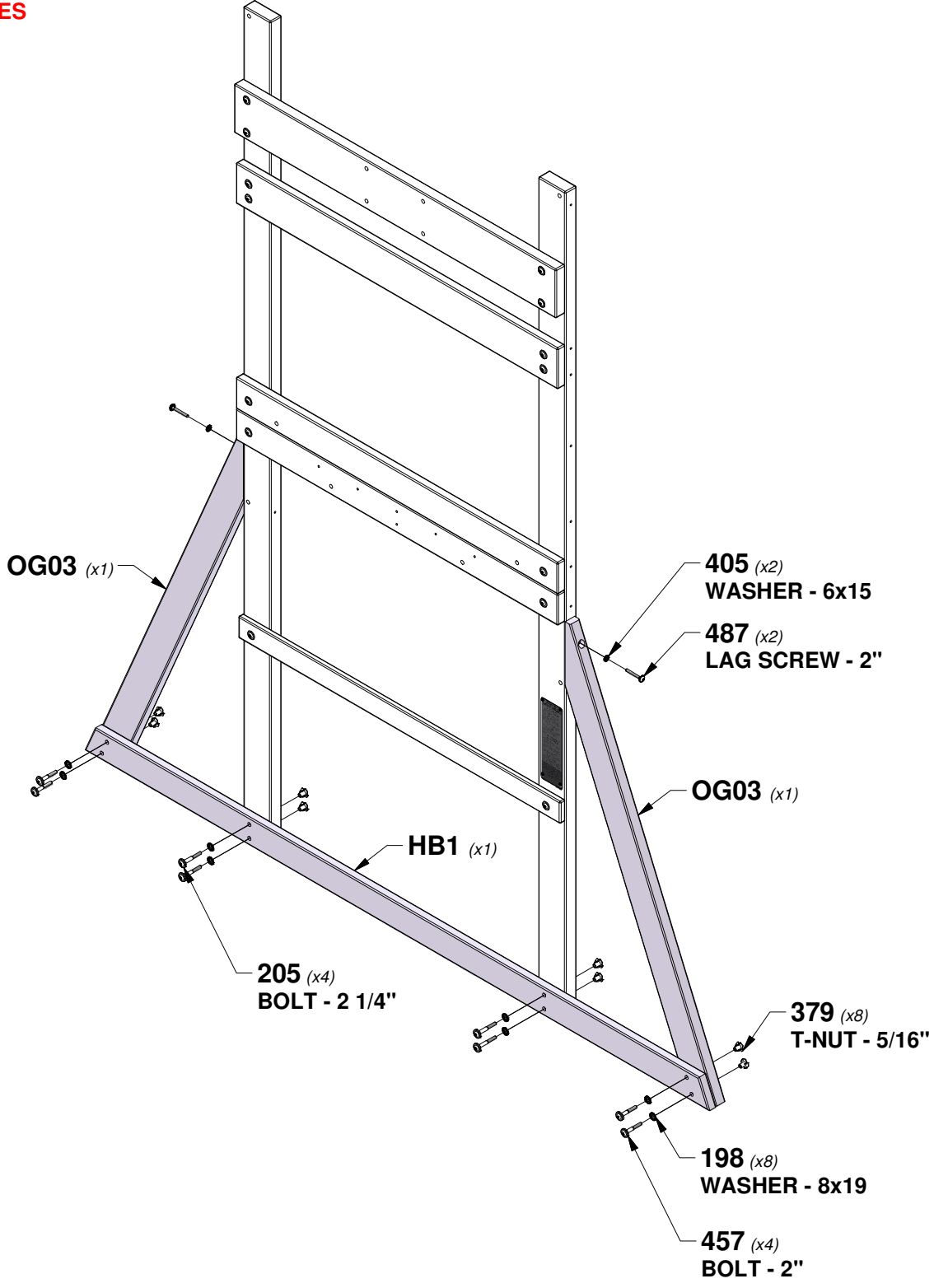

# STEP 2 - FORT ASSEMBLY

QTY	PART NUMBER	DESCRIPTION
8	H100197	LAG SCREW WH 5/16x2-1/2 BLK
18	H100198	WASHER LOCK EXT 8x19 BLK
4	H100379	T-NUT 5/16 BLK
6	H100458	LAG SCREW WH 5/16x2 BLK
4	H100513	BOLT WH 5/16x4 1/4 BLK

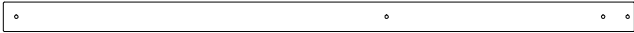

**E2 | UPRIGHT - W4L22705**  
(x1) | 1 3/8"x3 3/8"x73 1/8" (36x86x1856)



**E5 | UPRIGHT - W4L22706**  
(x1) | 1 3/8"x3 3/8"x73 1/8" (36x86x1856)

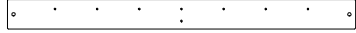

**H4 | FLOOR SUPPORT - W4L22678**  
(x1) | 1"x3 3/8"x40 3/8" (24x86x1024)



**H8 | FLOOR SUPPORT - W4L22682**  
(x1) | 1"x3 3/8"x40 3/8" (24x86x1024)



**Q3 | WALL RAIL - W4L22694**  
(x1) | 1"x4 3/8"x40 3/8" (24x112x1024)



**HB3 | GROUND BOARD - W4L22673**  
(x1) | 1"x3"x40 3/8" (24x76x1024)



**K3 | FLOOR SUPPORT - W4L14559**  
(x1) | 5/8"x5 1/4"x40 3/8" (16x134x1024)



**M2 | FLOOR SUPPORT - W4L14572**  
(x1) | 5/8"x3 3/8"x40 3/8" (16x86x1024)

- INSTALL T-NUTS IN WOOD FIRST
- ALIGN PILOT HOLES

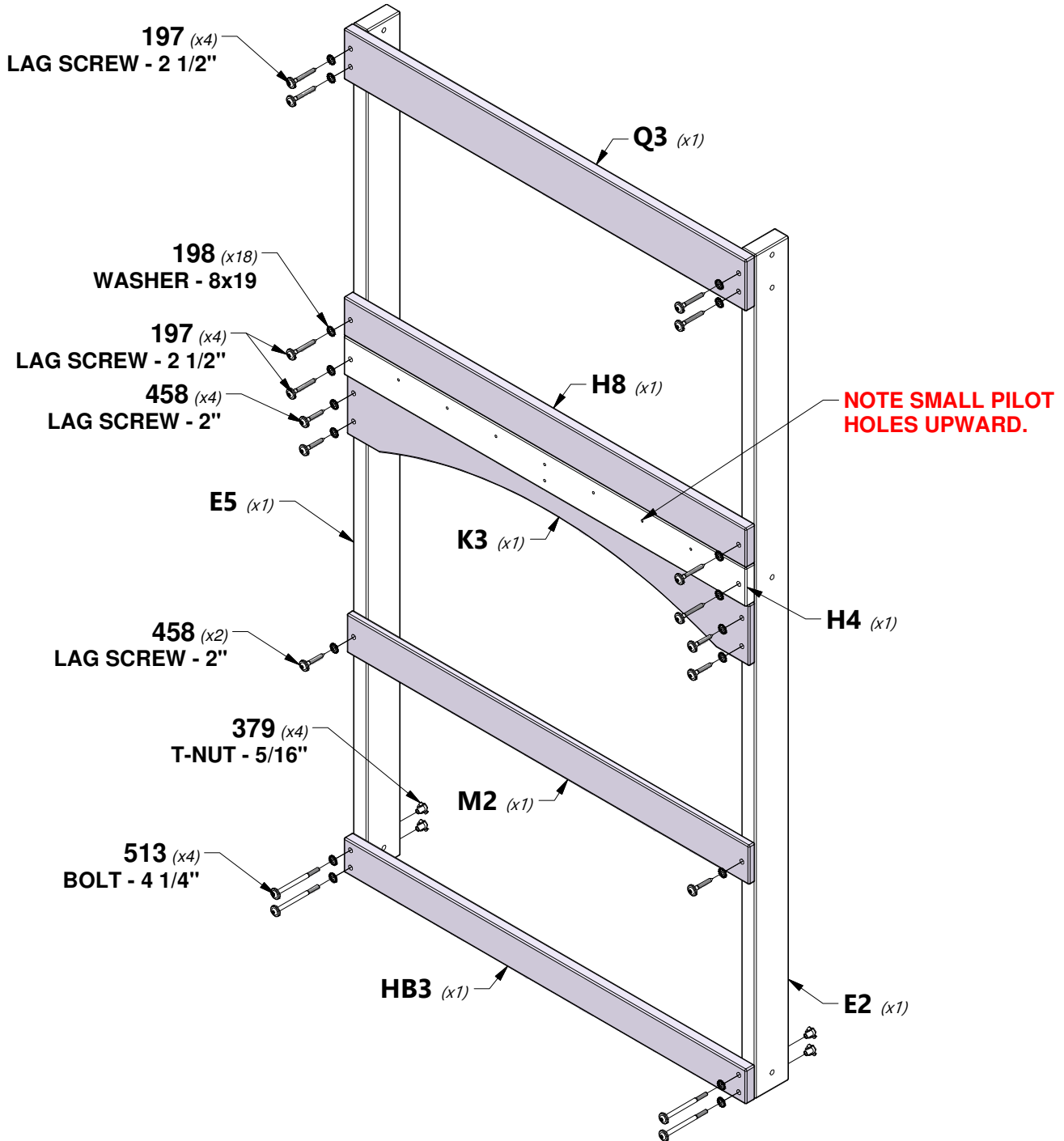

# STEP 3 - FORT ASSEMBLY

QTY	PART NUMBER	DESCRIPTION
6	H100197	LAG SCREW WH 5/16x2-1/2 BLK
16	H100198	WASHER LOCK EXT 8x19 BLK
8	H100205	BOLT WH 5/16x2-1/4 BLK
12	H100379	T-NUT 5/16 BLK
2	H100513	BOLT WH 5/16x4 1/4 BLK

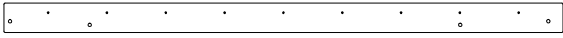

**H3** FLOOR SUPPORT - W4L22677  
(x1) 1"x3 3/8"x64 3/4" (24x86x1644)

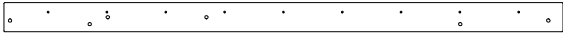

**H5** FLOOR SUPPORT - W4L22679  
(x1) 1"x3 3/8"x64 3/4" (24x86x1644)



**HB2** GROUND BOARD - W4L22672  
(x2) 1"x3"x64 3/4" (24x76x1644)



**Q2** WALL RAIL - W4L22693  
(x1) 1"x4 3/8"x64 3/4" (24x112x1644)



**Q4** WALL RAIL - W4L22695  
(x1) 1"x4 3/8"x64 3/4" (24x112x1644)

- INSTALL T-NUTS IN WOOD FIRST
- ALIGN PILOT HOLES

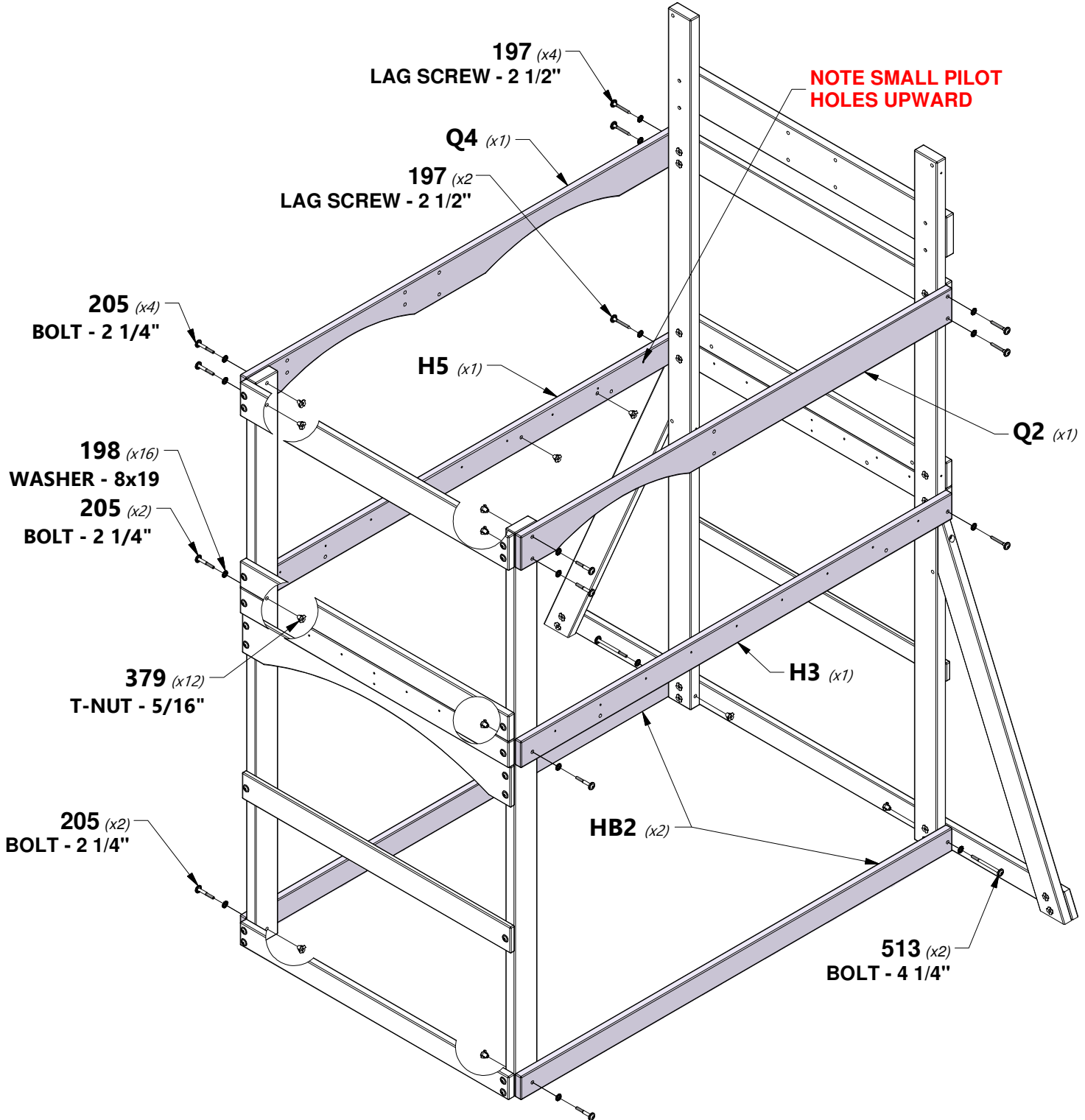

# STEP 4 - FORT ASSEMBLY



**OR01 | DECK BRACE - W4L22675**  
(x6) 1 1/8"x2 3/8"x14 5/8" (30x60x371)

QTY	PART NUMBER	DESCRIPTION
6	H100198	WASHER LOCK EXT 8x19 BLK
6	H100379	T-NUT 5/16 BLK
2	H100399	NUT BARREL WH 1/4x7/8 BLK
2	H100400	WASHER LOCK EXT 8x15 BLK
4	H100405	WASHER LOCK EXT 6x15 BLK
6	H100457	BOLT WH 5/16x2 BLK
4	H100487	LAG SCREW WH 1/4x2 BLK
2	H100488	BOLT WH 1/4x2 BLK

- INSTALL T-NUTS IN WOOD FIRST
- ALIGN PILOT HOLES

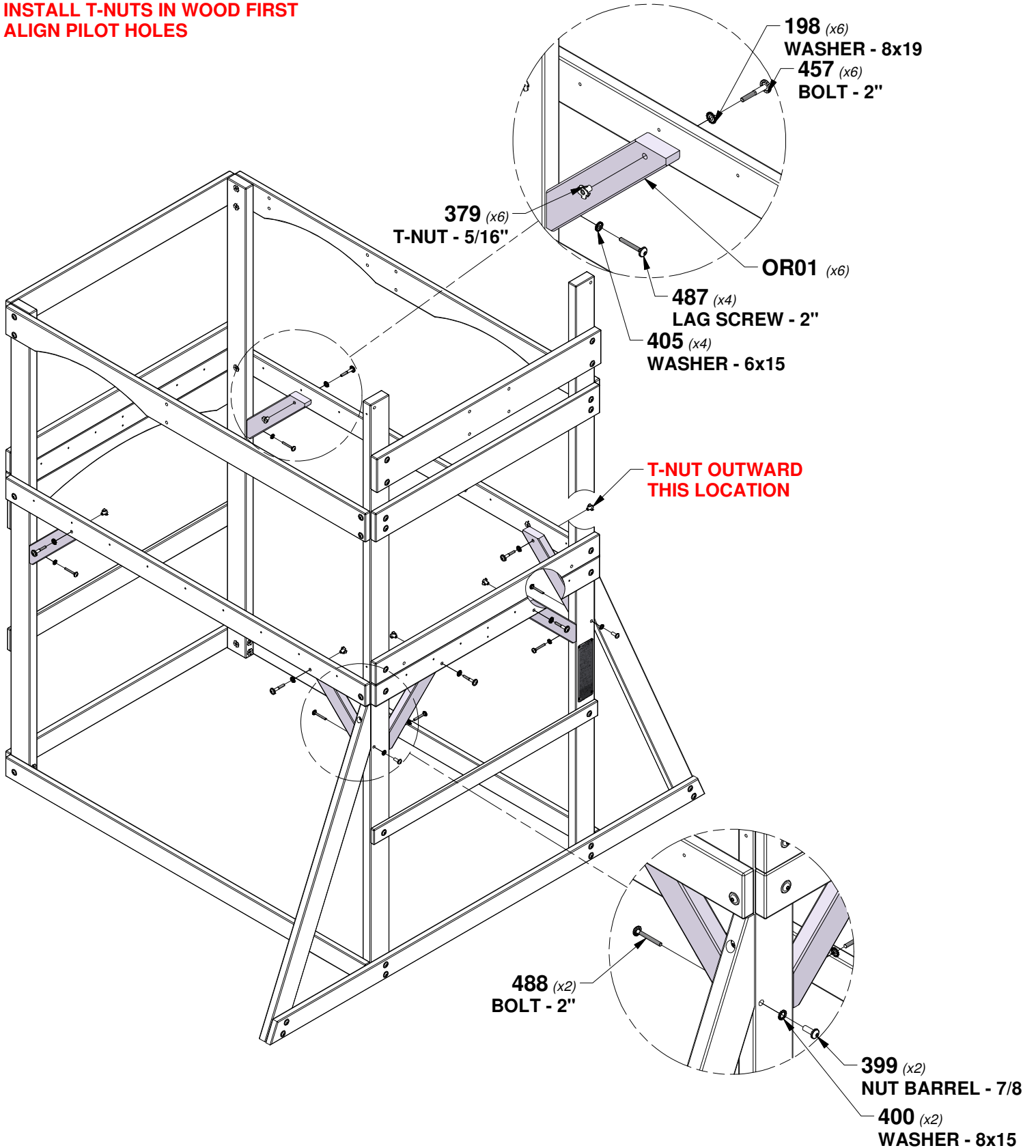

# STEP 5 - FORT ASSEMBLY

QTY	PART NUMBER	DESCRIPTION
46	H100088	SCREW PFH 8x1-1/8"



**M9** | WALL BOARD - W4L22707  
 (x2) | 5/8"x3 3/8"x42 1/4" (16x86x1074)



**M10** | WALL BOARD - W4L22708  
 (x9) | 5/8"x3 3/8"x22 1/4" (16x86x566)

**- NOTE EQUALLY SPACE WALL BOARDS**

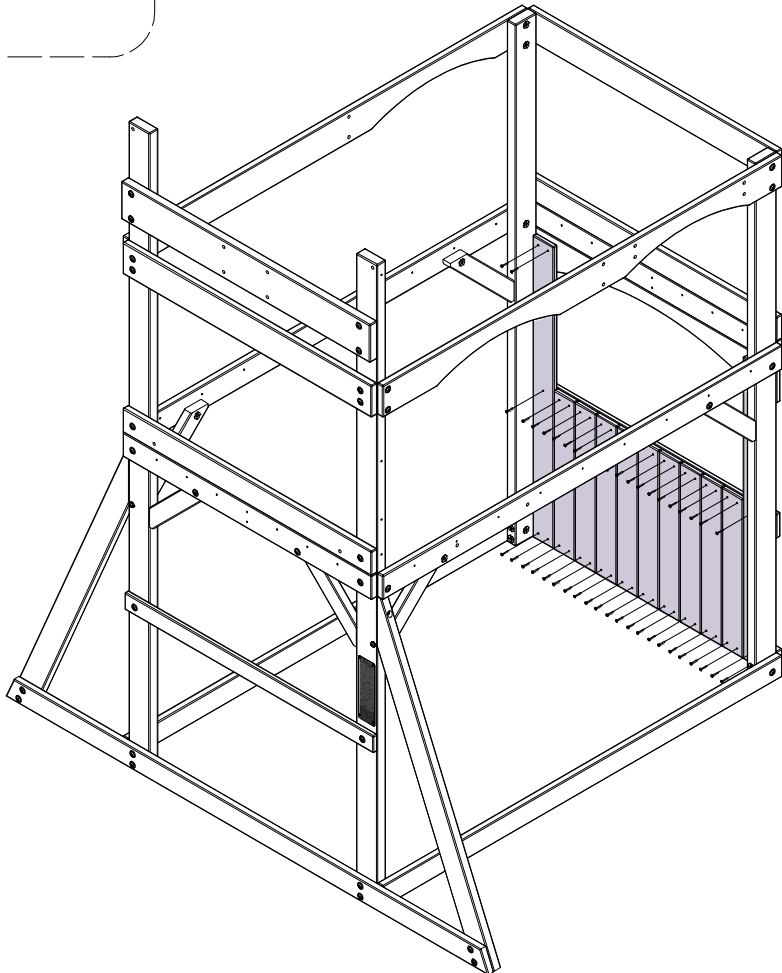
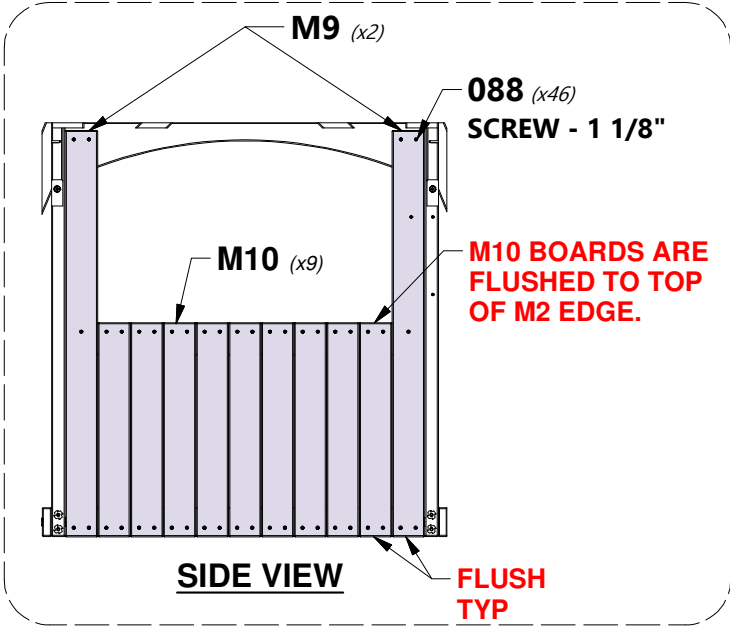

# STEP 6 - FORT ASSEMBLY

QTY	PART NUMBER	DESCRIPTION
5	H100086	SCREW PFH 8x1-1/2"
2	H100087	SCREW PFH 8x1-1/4"

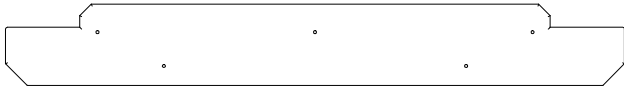

**G1** | COUNTER TOP - W4L22684  
 (x1) | 1"x5 1/4"x40 3/8" (24x134x1024)



**H1** | TABLE SUPPORT - W4L14543  
 (x2) | 1"x2"x4" (24x51x102)

- ALIGN PILOT HOLES
- INSTALL G1 BOARD FIRST, FOLLOWED BY H1

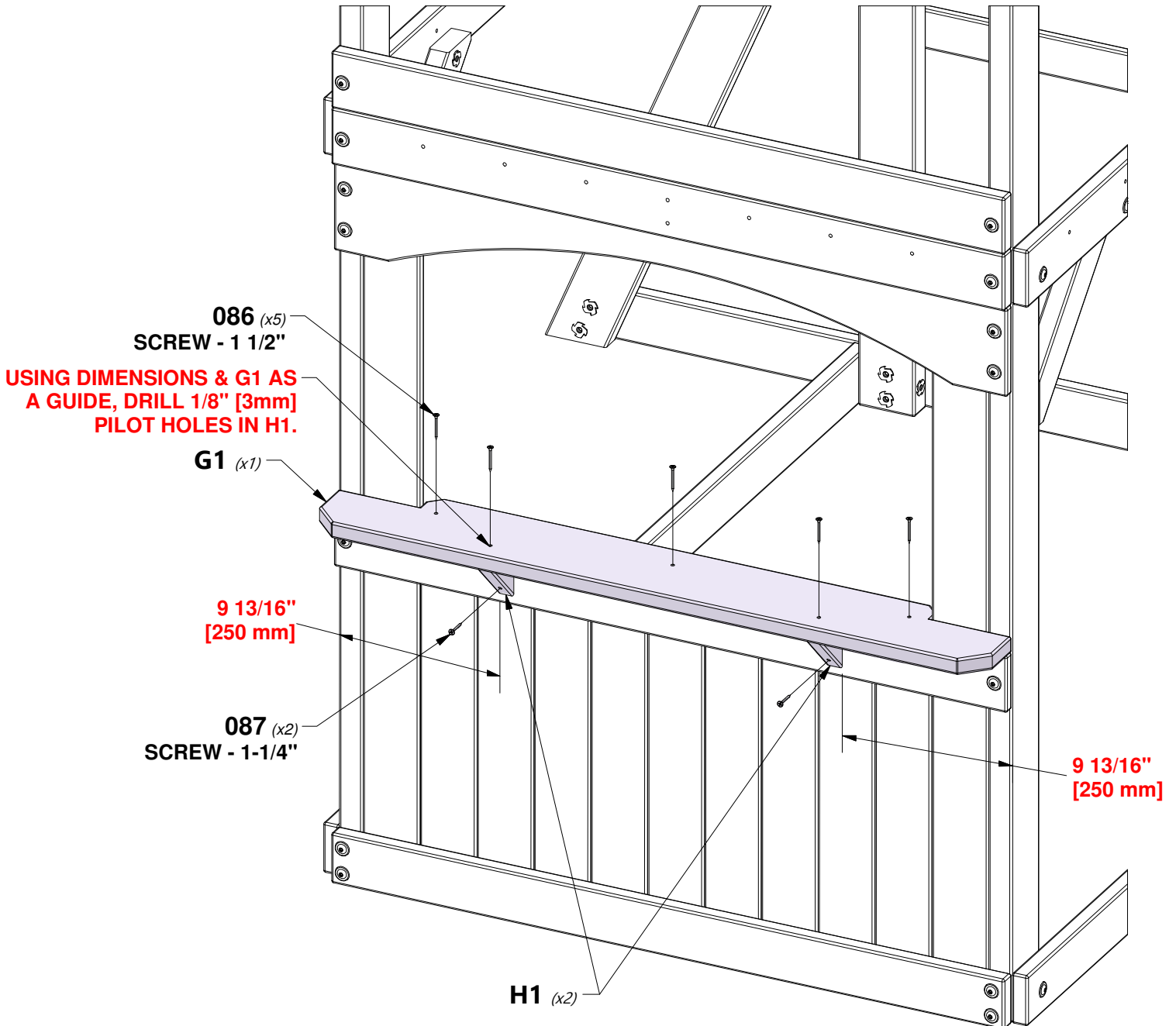

# STEP 7 - FORT ASSEMBLY

QTY	PART NUMBER	DESCRIPTION
30	H100089	SCREW PFH 8x1-3/4"

**T1 | FLOOR SUPPORT - W4L22688**  
(x1) | 1"x1 1/8"x33 1/2" (24x30x852)

**T3 | FLOOR SUPPORT - W4L22690**  
(x1) | 1 1/8"x1"x37 1/2" (30x24x952)

**T2 | FLOOR SUPPORT - W4L22689**  
(x2) | 1"x1 1/8"x59 7/8" (24x30x1522)

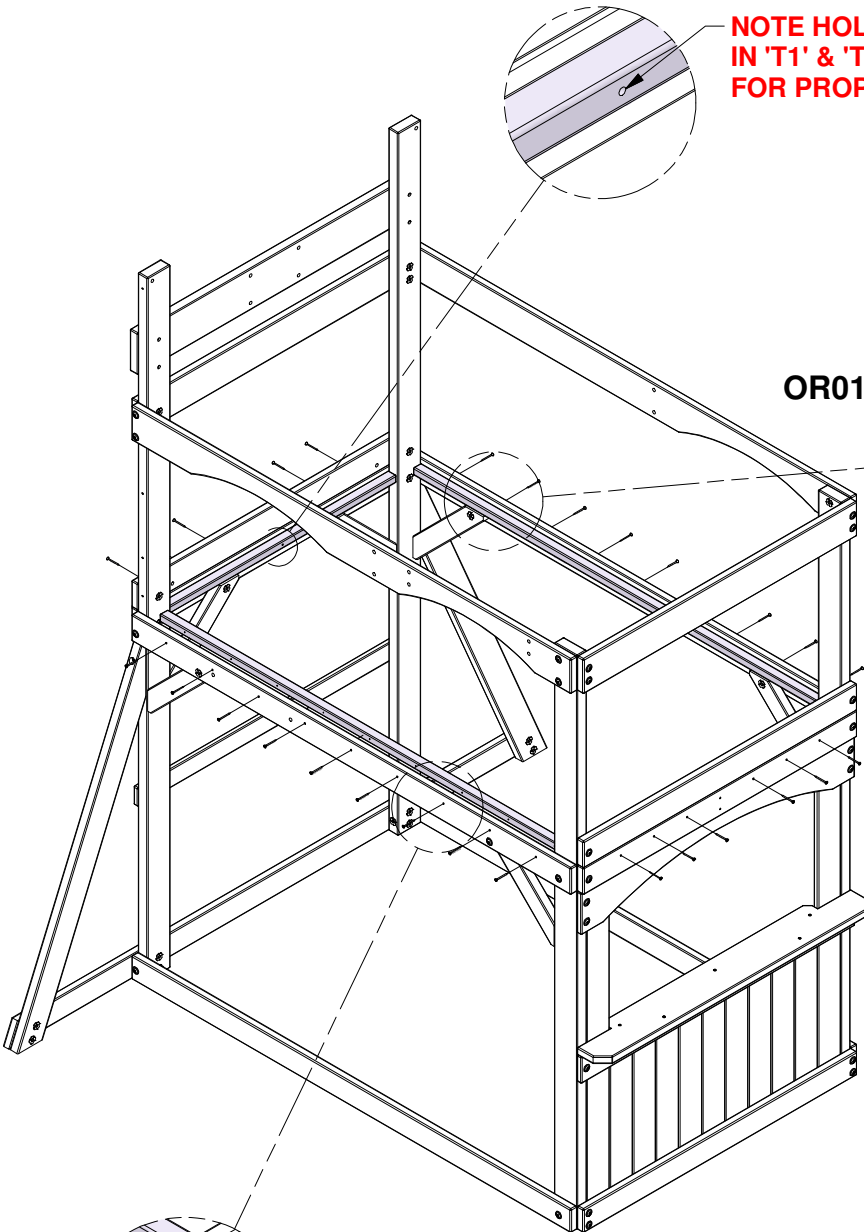

**NOTE HOLE LOCATION  
IN 'T1' & 'T3' BOARDS  
FOR PROPER ASSEMBLY.**

**089 (x30)  
SCREW - 1 3/4"**

**OR01**

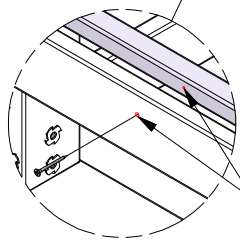

**ALIGN PILOT HOLES IN (T) BOARDS  
WITH THRU HOLES IN THEIR MATING  
BOARDS.**

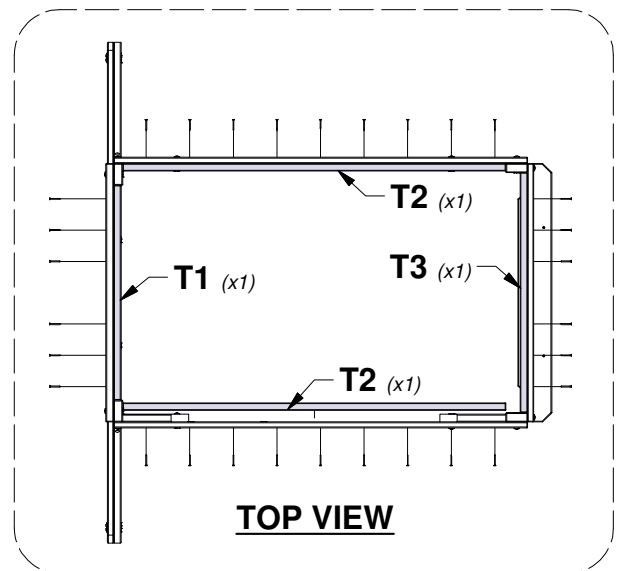

# STEP 8 - FORT ASSEMBLY

QTY	PART NUMBER	DESCRIPTION
4	H100092	SCREW PFH 8x3

**OR02** | JOIST - W4L22691  
(x1) | 1 1/8"x2 3/8"x64 3/4" (30x60x1644)

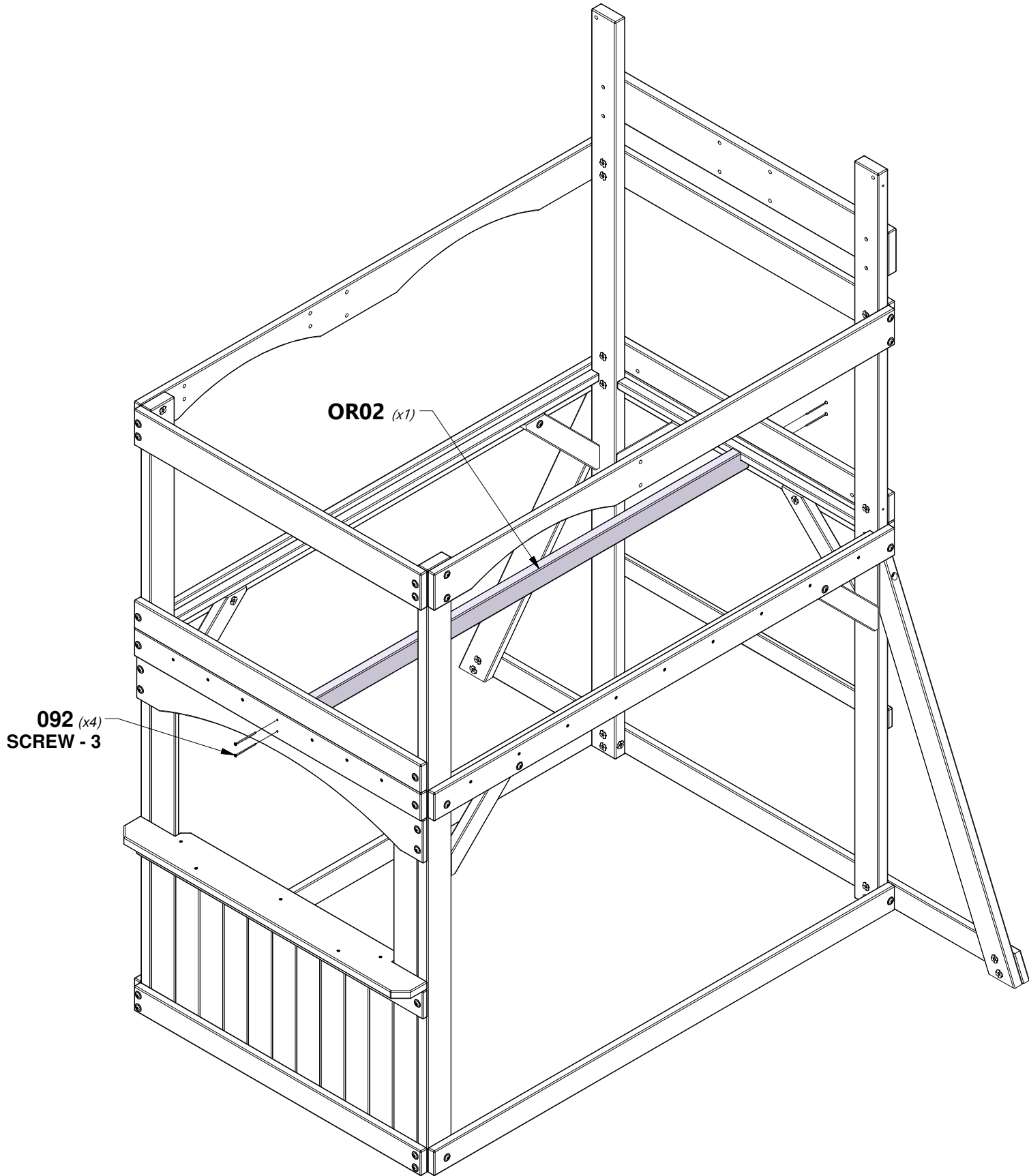

# STEP 9 - FORT ASSEMBLY

QTY	PART NUMBER	DESCRIPTION
95	H100086	SCREW PFH 8x1-1/2"

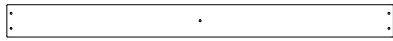

**M4 | FLOOR BOARD - W4L14574**  
(x2) | 5/8"x3 3/8"x40 3/8" (16x86x1024)

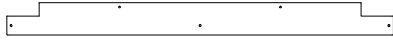

**M5 | FLOOR BOARD - W4L22777**  
(x1) | 5/8"x3 3/8"x40 3/8" (16x86x1024)

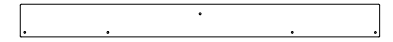

**M6 | FLOOR BOARD - W4L22778**  
(x1) | 5/8"x3 3/8"x37 1/2" (16x86x952)

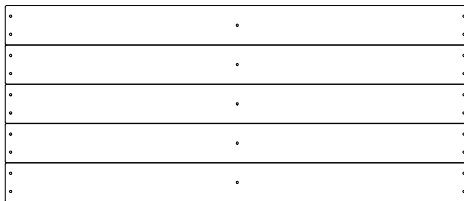

**FP1 | FLOOR PANEL - W2A03131**  
(x3) | 1 1/4"x17"x40 5/16" (32x432x1024)

**- NOTE EQUALLY SPACE FLOOR BOARDS**

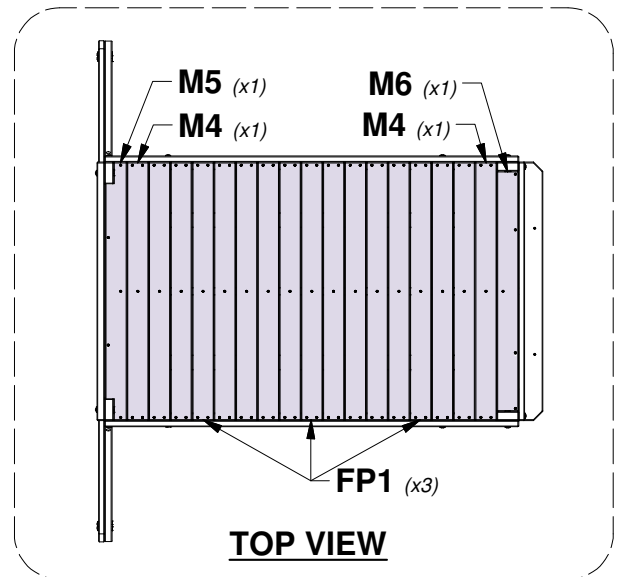
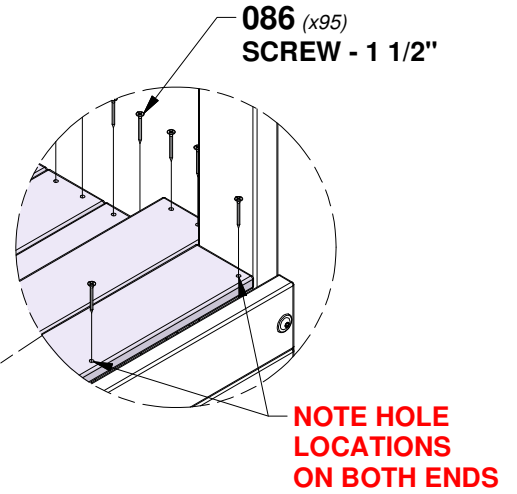
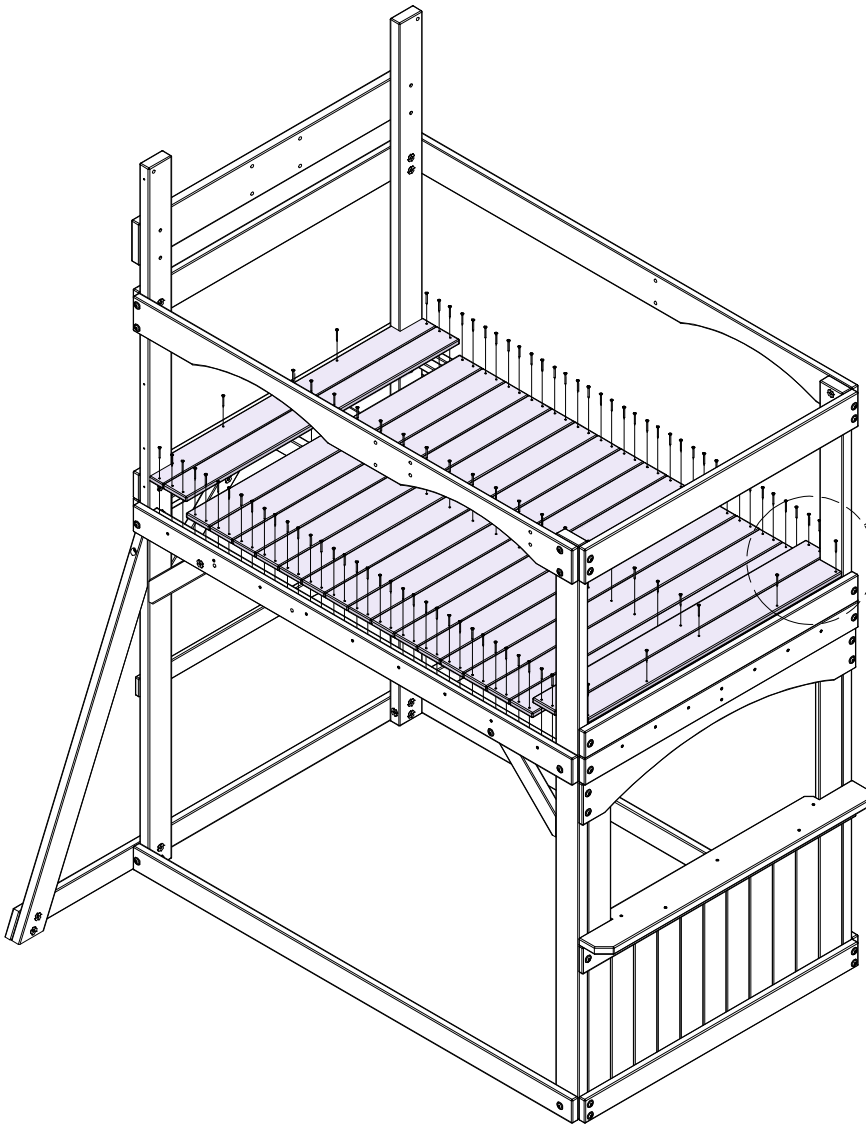

# STEP 10 - FORT ASSEMBLY

QTY	PART NUMBER	DESCRIPTION
4	H100198	WASHER LOCK EXT 8x19 BLK
4	H100205	BOLT WH 5/16x2-1/4 BLK
4	H100379	T-NUT 5/16 BLK

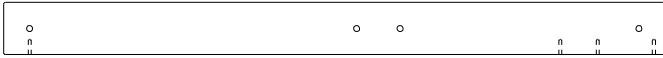

**E4 | CLUB HOUSE LEG - W4L14534**  
(x1) | 1 3/8"x3 3/8"x43 1/8" (36x86x1094)

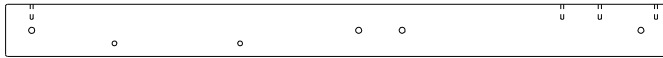

**E8 | CLUB HOUSE LEG - W4L14537**  
(x1) | 1 3/8"x3 3/8"x43 1/8" (36x86x1094)

## - INSTALL T-NUTS IN WOOD FIRST

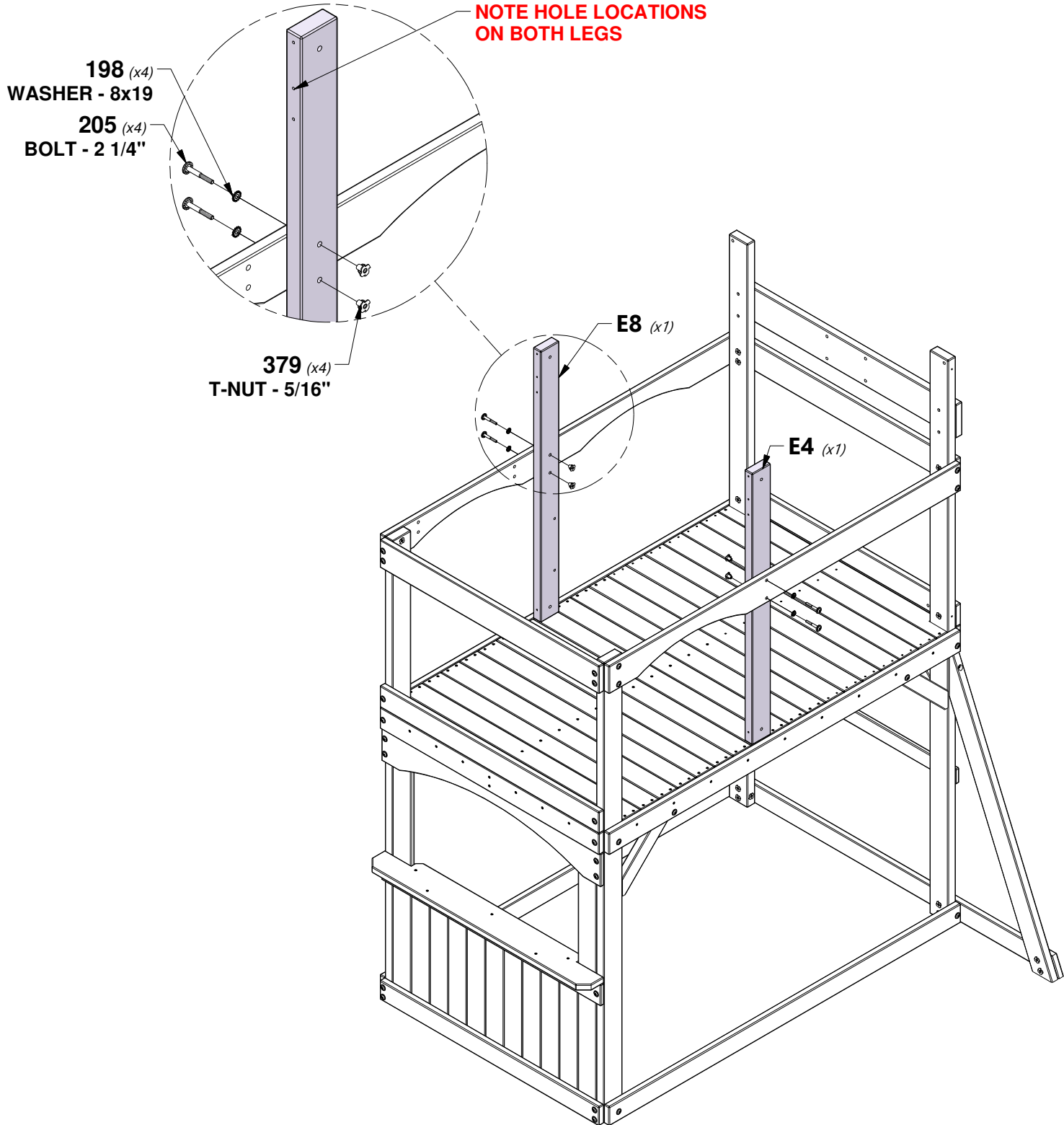

# STEP 11 - FORT ASSEMBLY

QTY	PART NUMBER	DESCRIPTION
2	H100192	NUT BARREL WH 5/16x7/8 BLK
4	H100197	LAG SCREW WH 5/16x2-1/2 BLK
4	H100198	WASHER LOCK EXT 8x19 BLK
2	H100199	WASHER LOCK EXT 12x19 BLK
2	H100379	T-NUT 5/16 BLK
2	H100396	BOLT WH 5/16x1/2 BLK
2	H100457	BOLT WH 5/16x2 BLK

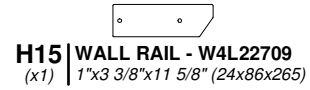
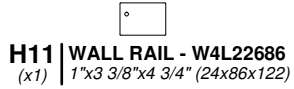
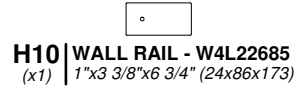
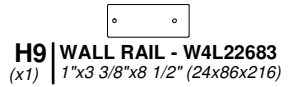
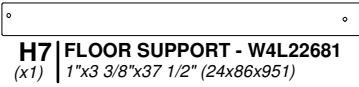

**- INSTALL T-NUTS IN WOOD FIRST**  
**- ALIGN PILOT HOLES**

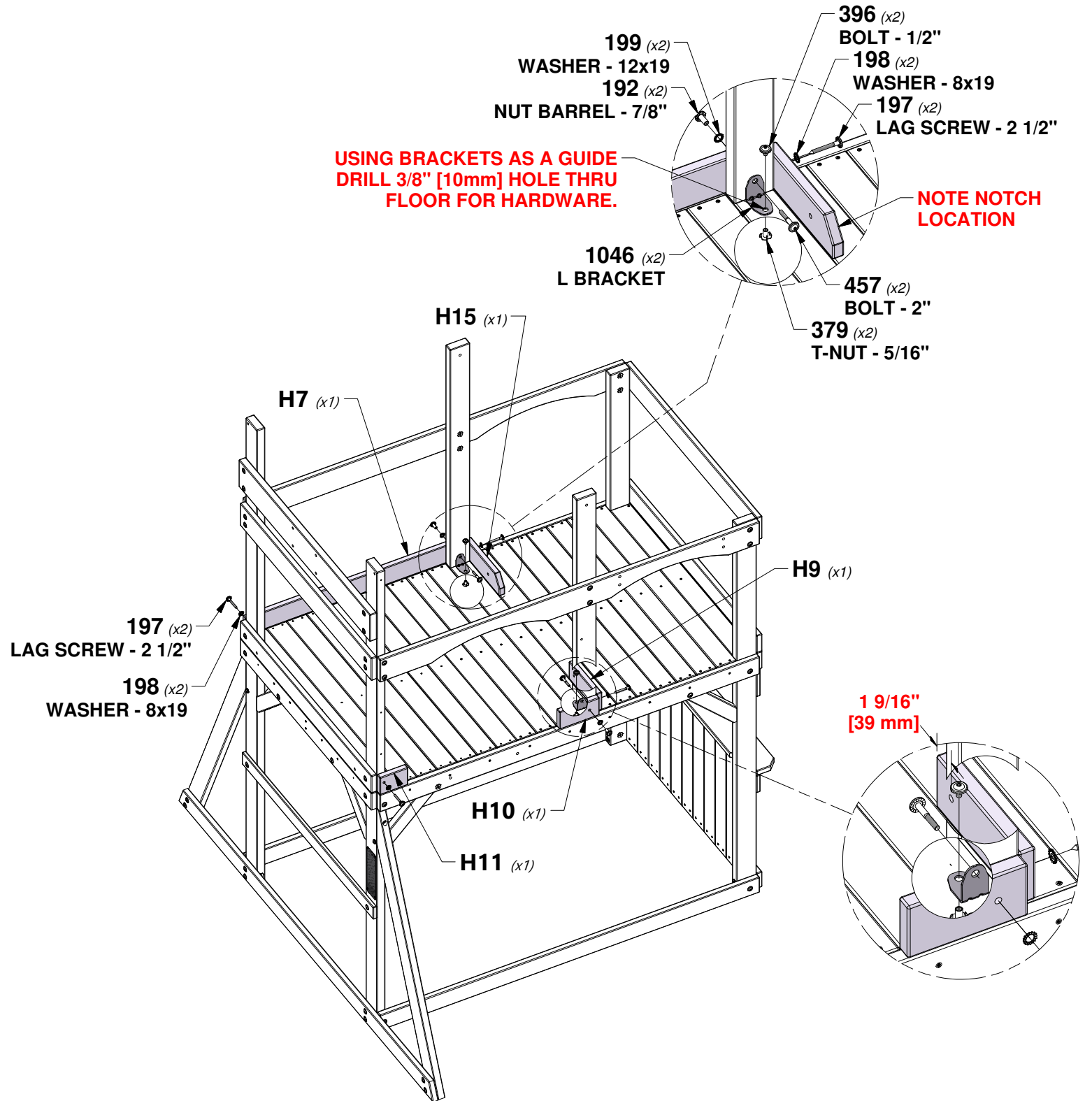

# STEP 12 - FORT ASSEMBLY

QTY	PART NUMBER	DESCRIPTION
12	H100088	SCREW PFH 8x1-1/8"



**N2 | PICKET - W4L14603**  
 (x6) | 5/8"x2 3/8"x22" (16x60x558)

**- NOTE EQUALLY SPACE PICKETS**

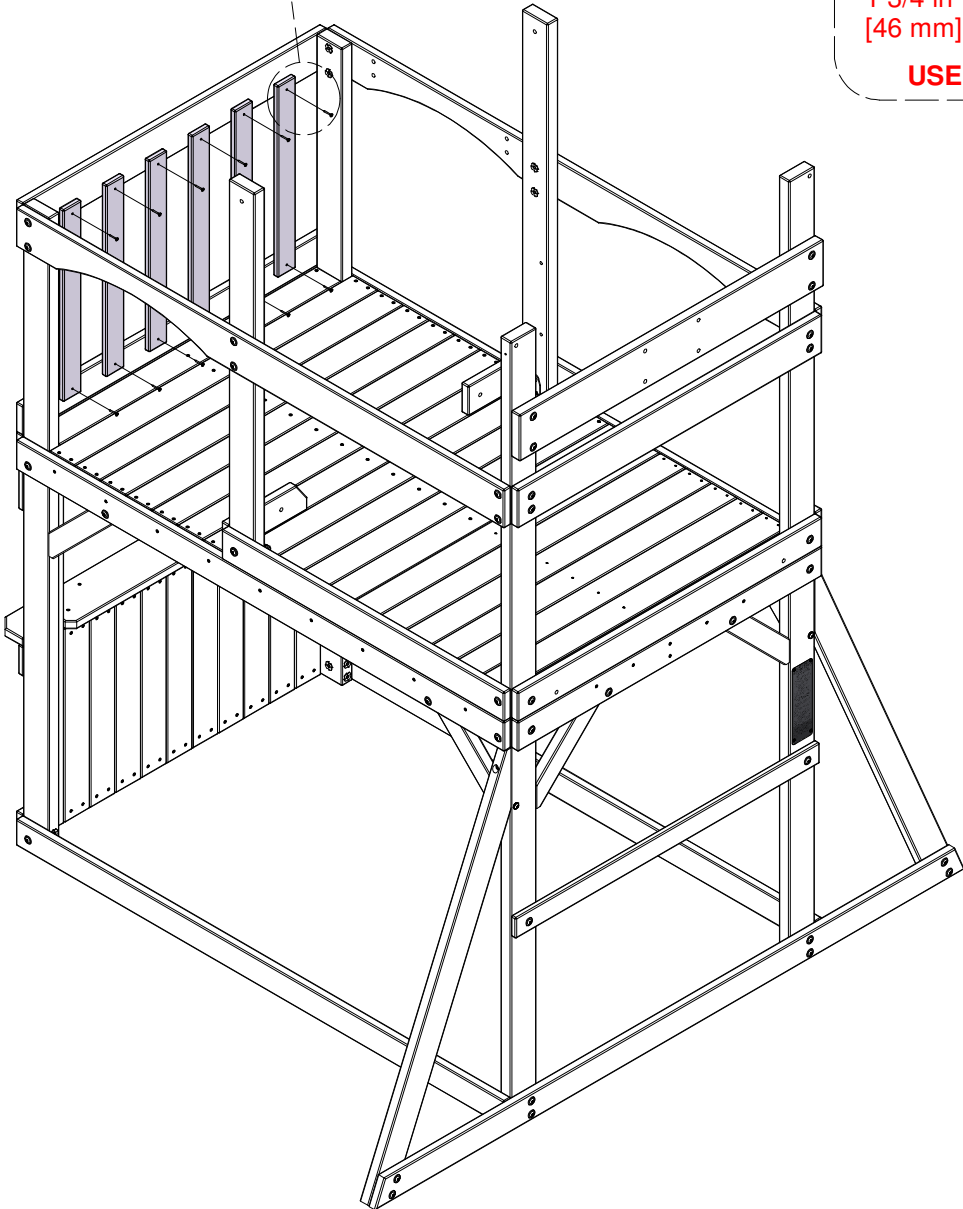
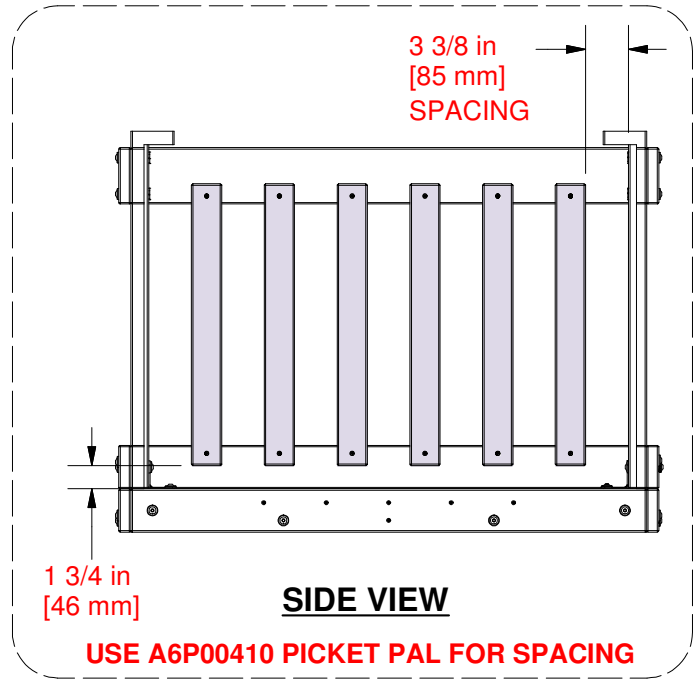
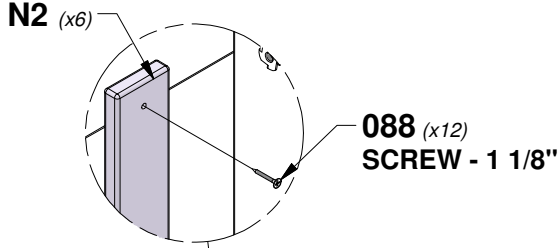

# STEP 13 - FORT ASSEMBLY

QTY	PART NUMBER	DESCRIPTION
8	H100198	WASHER LOCK EXT 8x19 BLK
2	H100197	LAG SCREW WH 5/16x2-1/2 BLK
2	H100379	T-NUT 5/16 BLK
2	H100205	BOLT WH 5/16x2-1/4 BLK
4	H100458	LAG SCREW WH 5/16x2 BLK



**L5 | CLUB HOUSE WALL RAIL - W4L14567**  
*(x1) 5/8"x4 3/8"x40 3/8" (16x112x1024)*

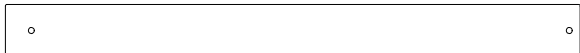

**H14 | WALL RAIL - W4L22699**  
*(x2) 1"x3 3/8"x37 1/2" (24x86x951)*

- INSTALL T-NUTS IN WOOD FIRST
- ALIGN PILOT HOLES

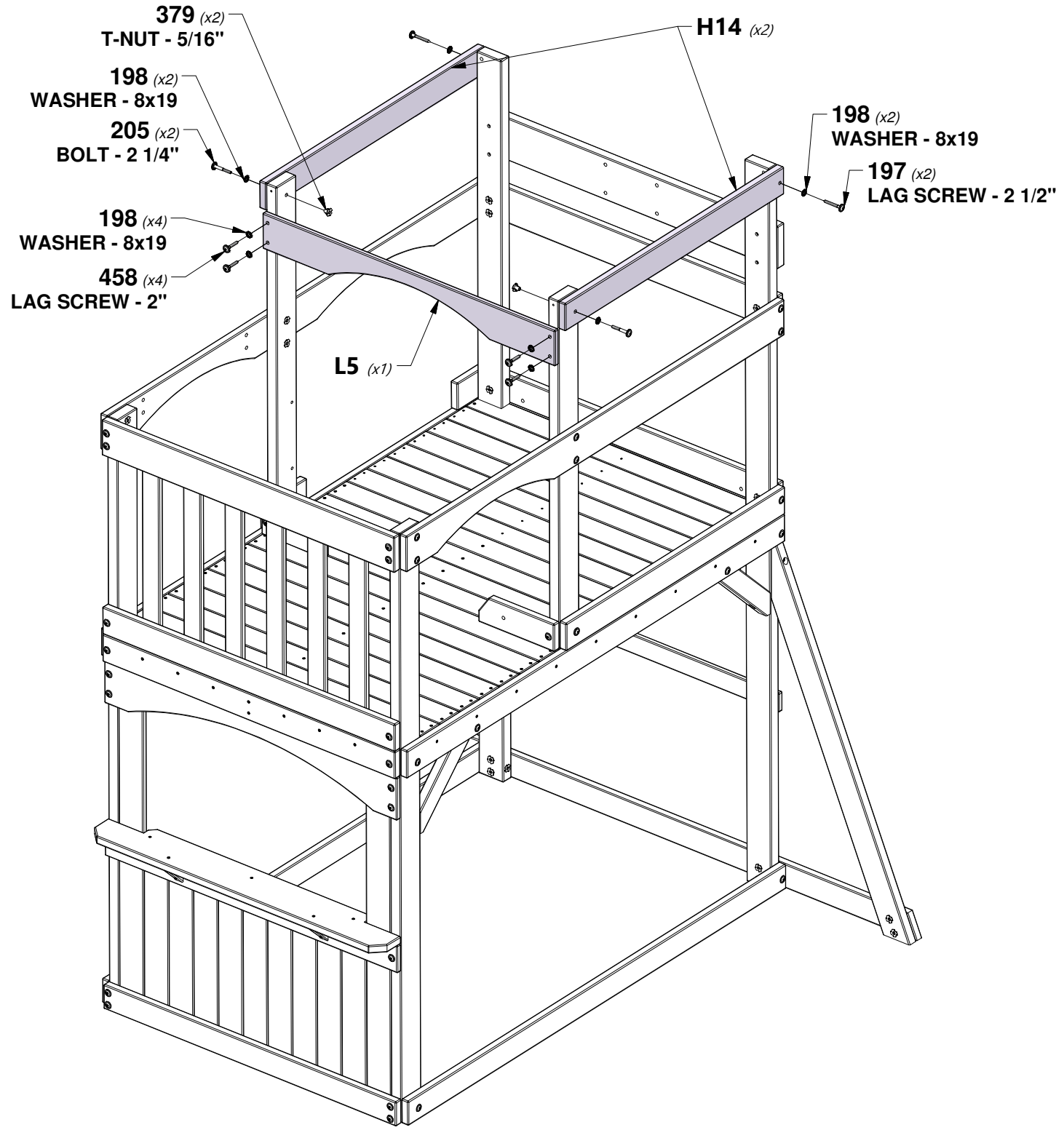

# STEP 14 - FORT ASSEMBLY

QTY	PART NUMBER	DESCRIPTION
16	H100088	SCREW PFH 8x1-1/8"
2	H100192	NUT BARREL WH 5/16x7/8 BLK
2	H100199	WASHER LOCK EXT 12x19 BLK
2	H100379	T-NUT 5/16 BLK
2	H100396	BOLT WH 5/16x1/2 BLK
2	H100459	BOLT WH 5/16x1 1/4 BLK

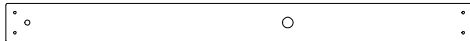

**M14** | WALL BOARD - W4L22712  
(x1) 5/8"x3"x36 1/2" (16x76x926)



**M33** | WALL BOARD - W4L22710  
(x1) 5/8"x3"x36 1/2" (16x76x926)



**Y1** | WALL BOARD - W4L14616  
(x2) 5/8"x4"x34 5/8" (16x102x880)



**A4M01046** | L BRACKET  
(x2) 2.5x38x55x55

**- INSTALL ALL 088 WOOD SCREWS FIRST.  
THEN INSTALL BRACKETS AND REMAINING HARDWARE.**

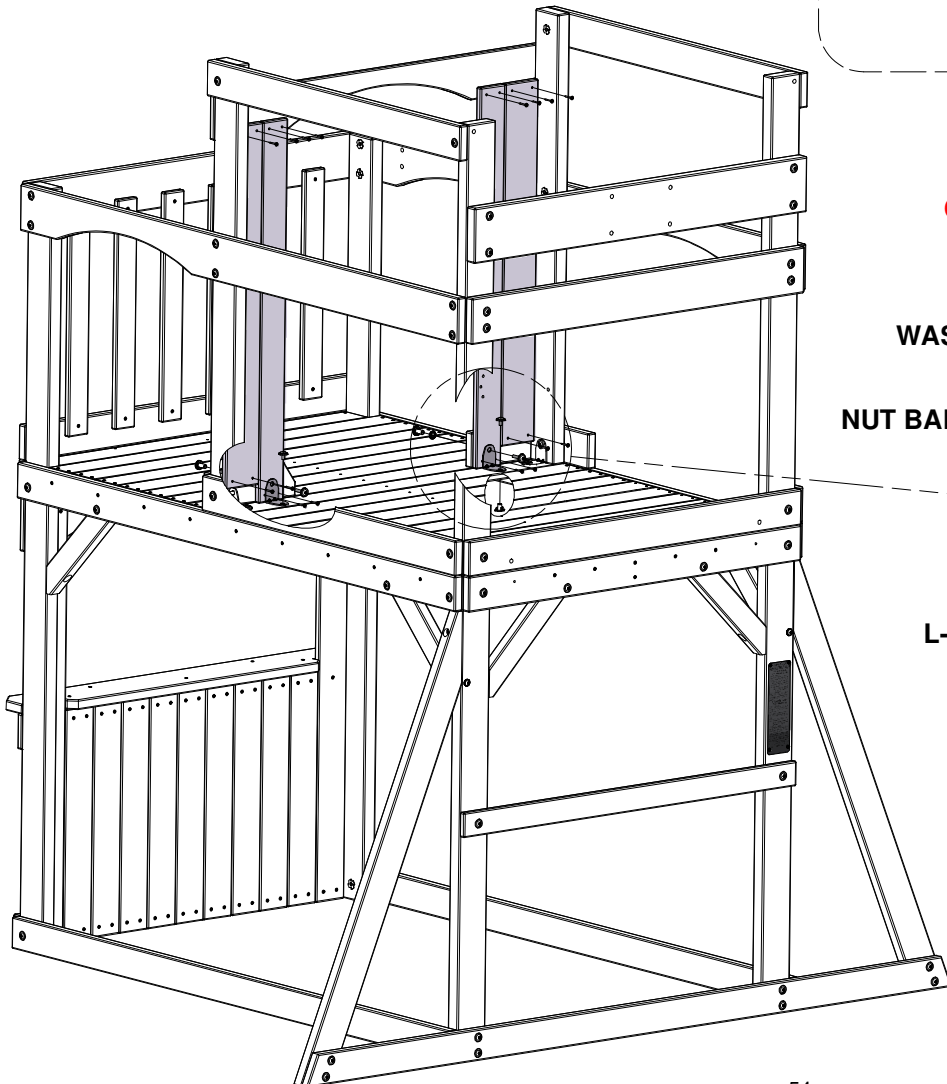
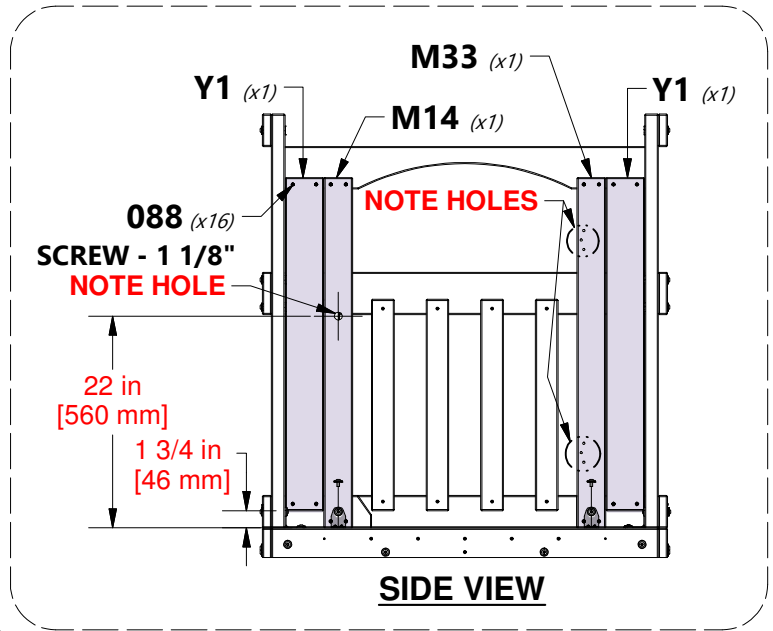

**NOTE HOLES FOR  
CORRECT ASSEMBLY**

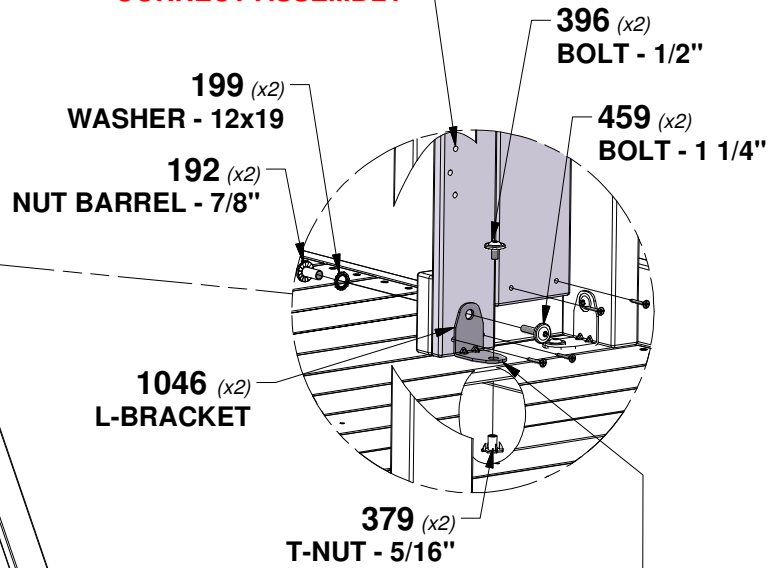

**USING BRACKETS AS A GUIDE  
DRILL 3/8" [10mm] HOLE THRU  
FLOOR FOR HARDWARE.**

# STEP 15 - FORT ASSEMBLY

QTY	PART NUMBER	DESCRIPTION
2	H100174	SCREW PFH 6x1
2	H100624	SCREW PFH 6x5/8 BLK

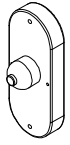

A100174 BODY DOOR BELL  
(x1)

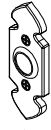

A6P00290 DOOR BELL PLATE  
(x1)

174 (x2)  
SCREW - 6x1"  
174 (x1)  
DOOR BELL

(x1) DOOR BELL  
RUBBER BUTTON

290 (x1)  
DOOR BELL PLATE

624 (x2)  
SCREW - 5/8"

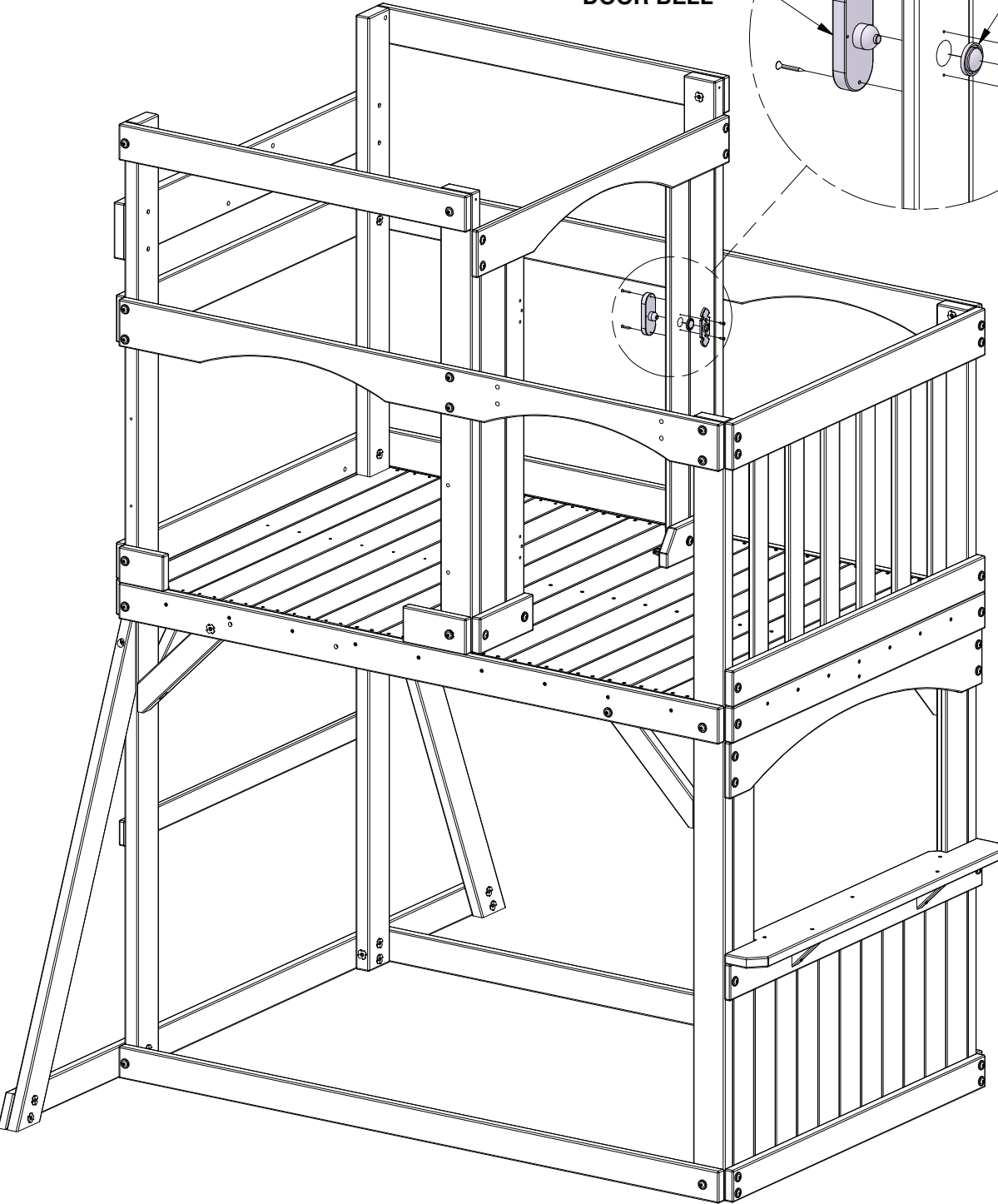
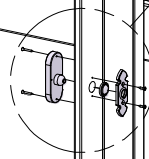
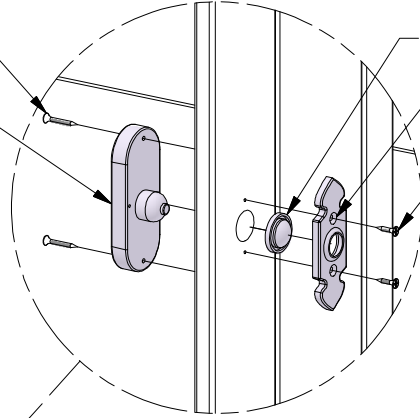

# STEP 16 - FORT ASSEMBLY

QTY	PART NUMBER	DESCRIPTION
36	H100088	SCREW PFH 8x1-1/8"



**M19** | WALL BOARD - W4L14589  
(x2) | 5/8"x3 3/8"x40 5/8" (16x86x1032)



**M20** | WALL BOARD - W4L14590  
(x2) | 5/8"x3 3/8"x16 1/4" (16x86x412)



**M26** | WALL BOARD - W4L14596  
(x8) | 5/8"x3 3/8"x3 1/2" (16x86x88)



**K6** | WALL BOARD - W4L14562  
(x1) | 5/8"x5 1/4"x16 1/4" (16x134x412)

**- NOTE EQUALLY SPACE WALL BOARDS**

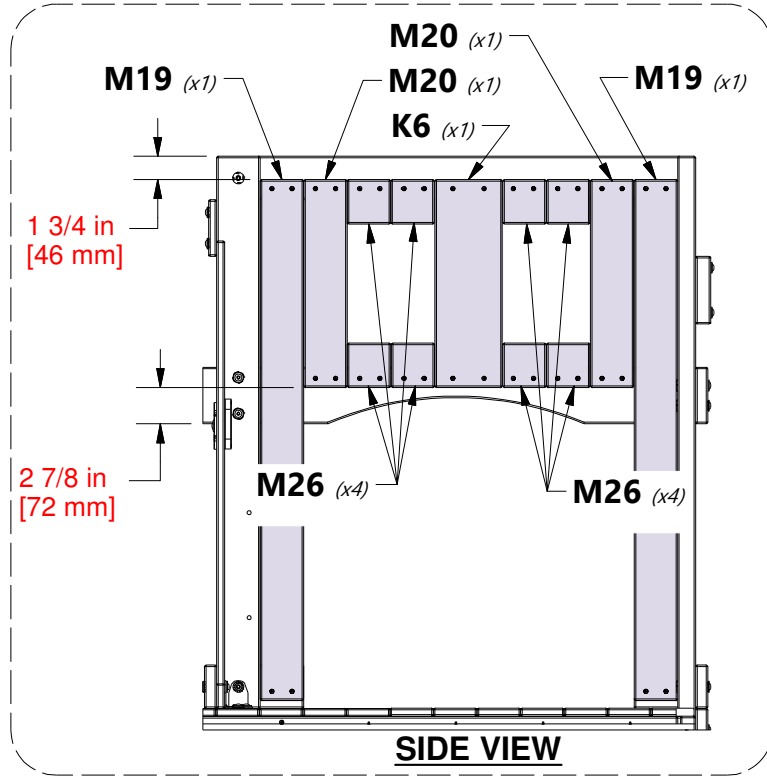

**088** (x36)  
**SCREW - 1 1/8"**

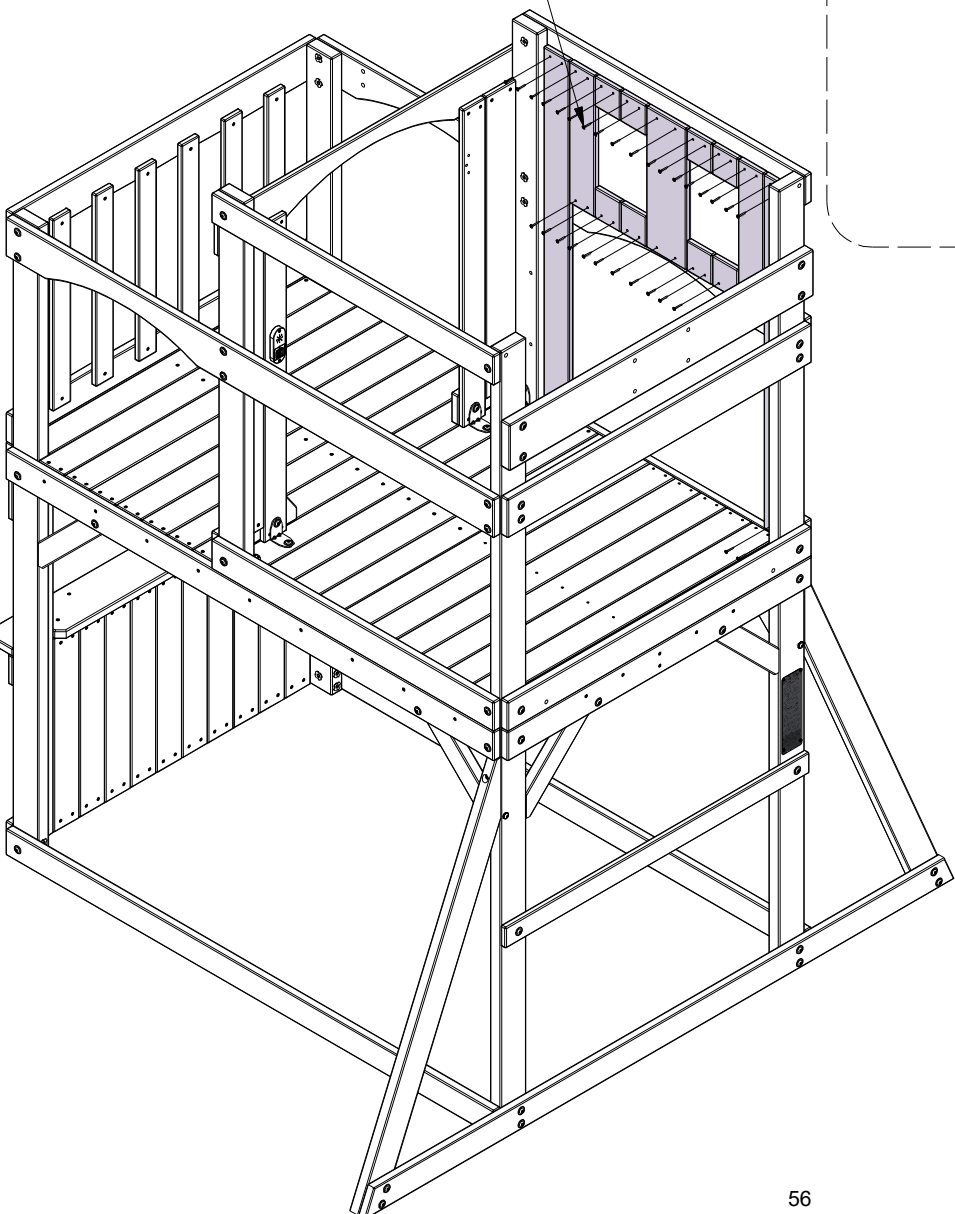

# STEP 17 - FORT ASSEMBLY

QTY	PART NUMBER	DESCRIPTION
30	H100088	SCREW PFH 8x1-1/8"

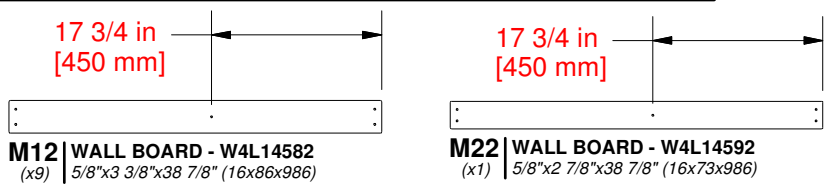

**- NOTE EQUALLY SPACE WALL BOARDS**

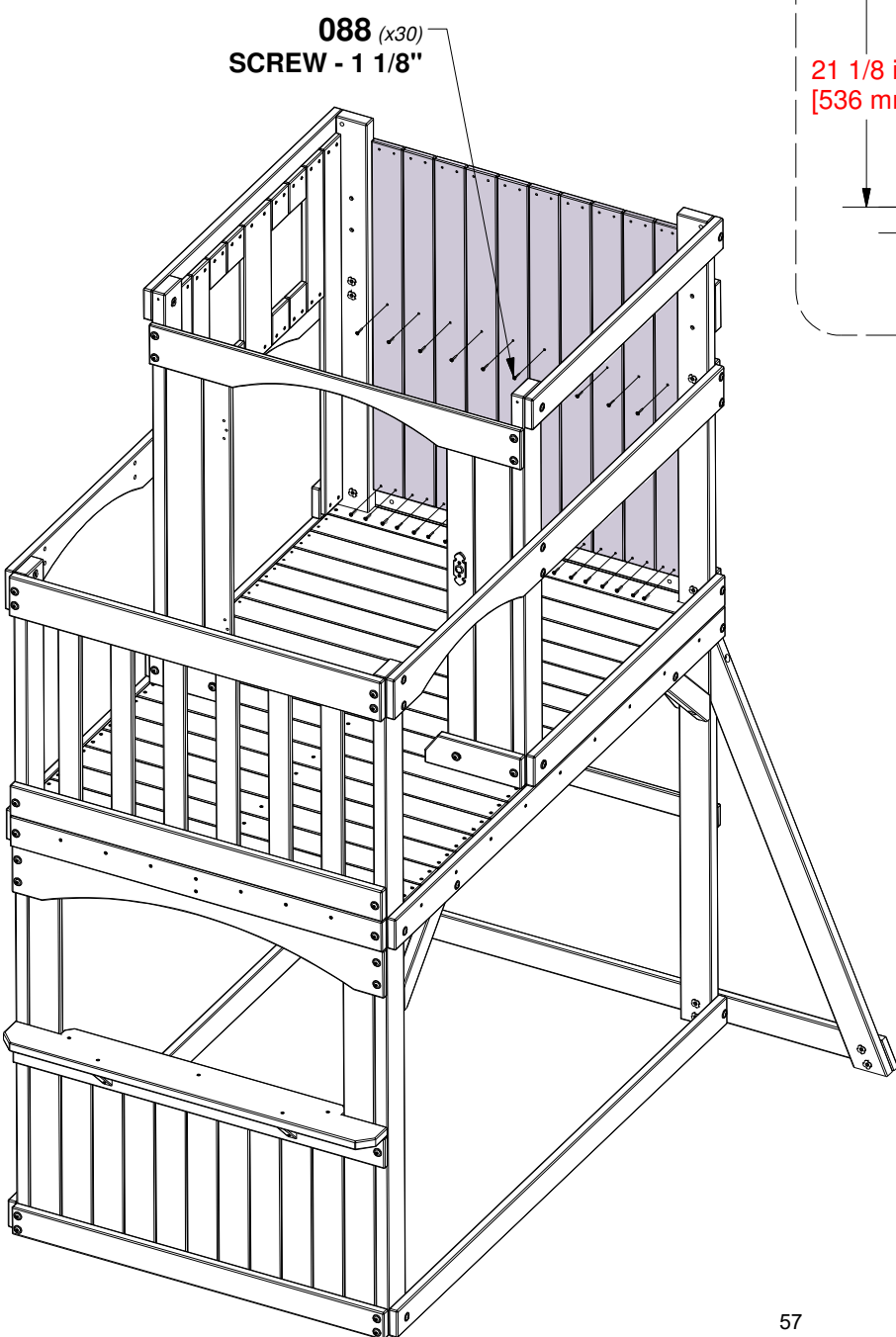
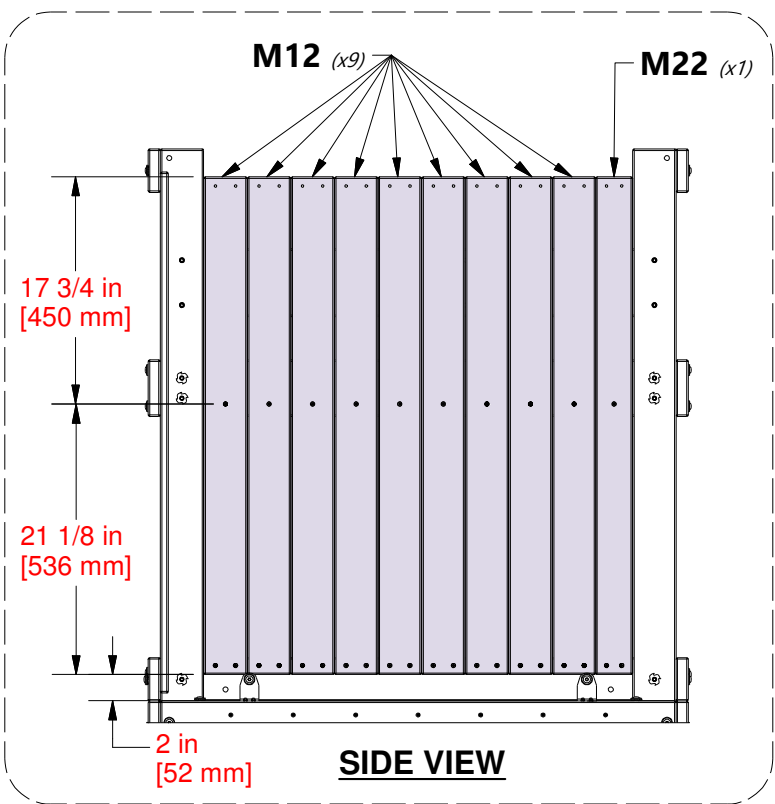

# STEP 18 - FORT ASSEMBLY

QTY	PART NUMBER	DESCRIPTION
38	H100088	SCREW PFH 8x1-1/8"

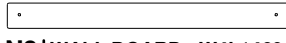

**N3 | WALL BOARD - W4L14604**  
(x1) | 5/8"x2"x22" (16x50x558)



**M13 | WALL BOARD - W4L14583**  
(x9) | 5/8"x3 3/8"x22" (16x86x558)

**- NOTE EQUALLY SPACE WALL BOARDS**

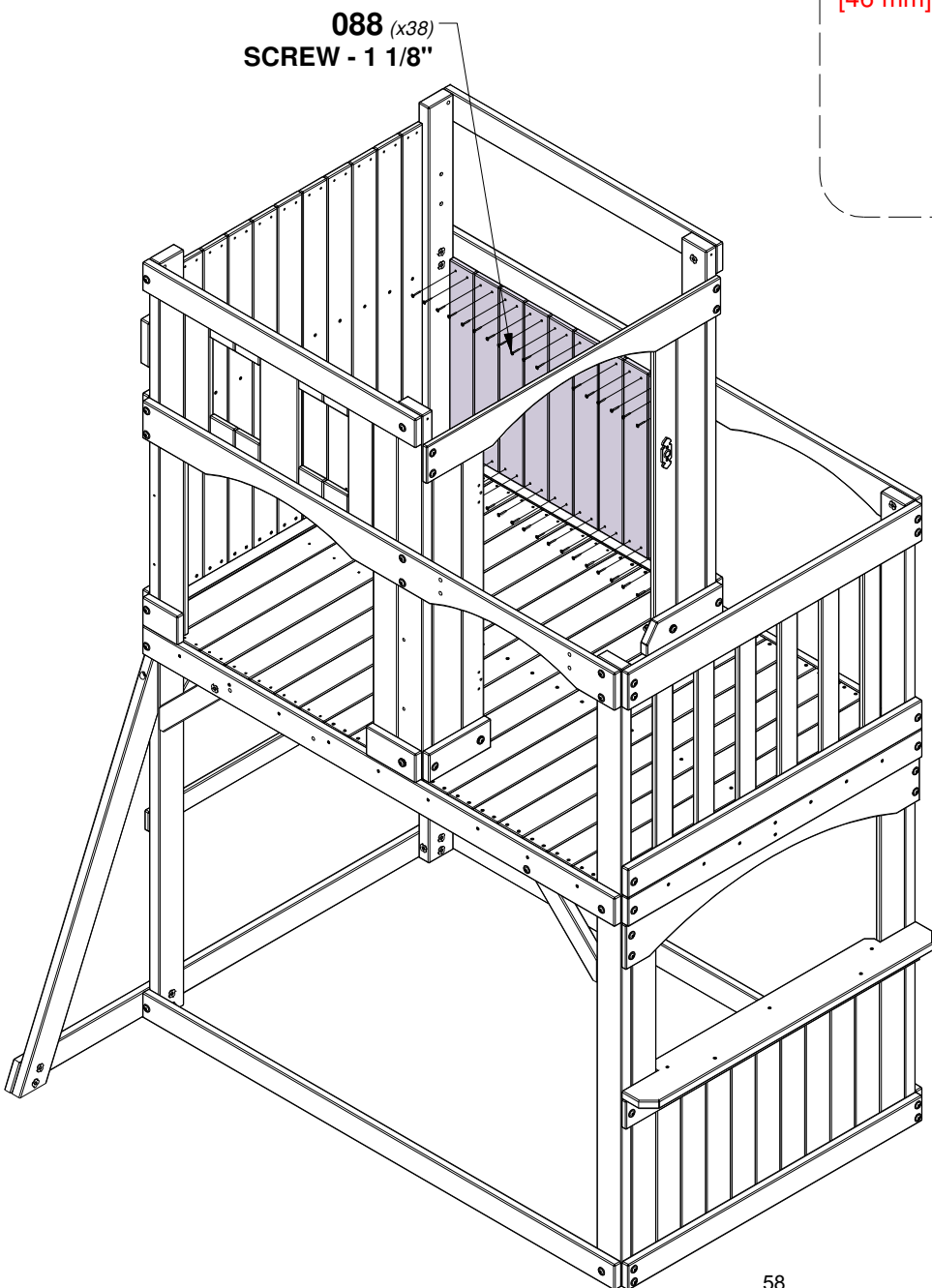
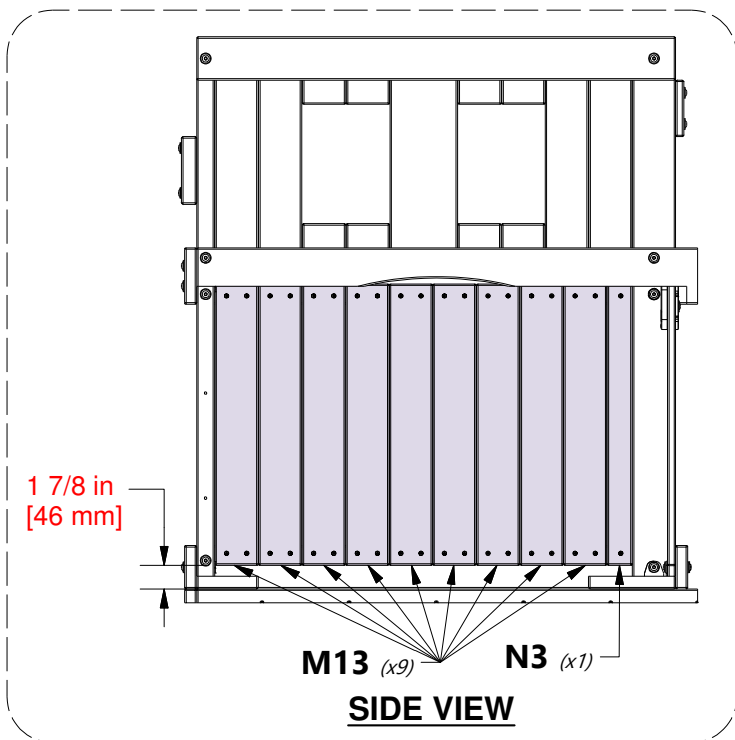

# STEP 19 - FORT ASSEMBLY

QTY	PART NUMBER	DESCRIPTION
8	H100070	SCREW PWH 8x3/4

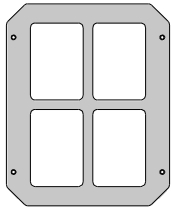

**A100014** | PLASTIC WINDOW WHITE  
(x2)

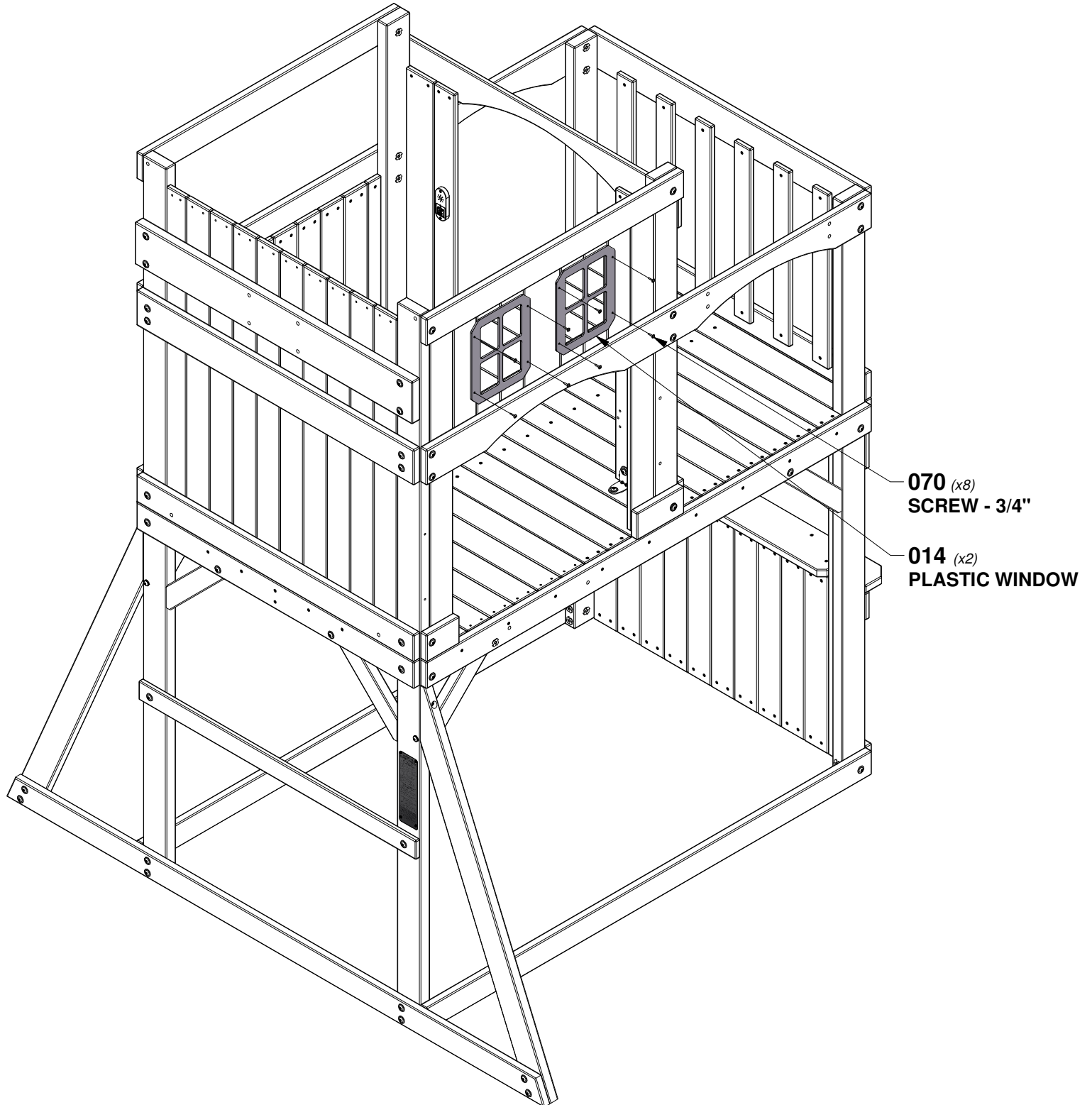

# STEP 20 - FORT ASSEMBLY

QTY	PART NUMBER	DESCRIPTION
4	H100088	SCREW PFH 8x1-1/8"



**O2** | WALL BOARD - W4L14610  
 (x2) | 5/8"x1 3/8"x15 1/2" (16x34x395)

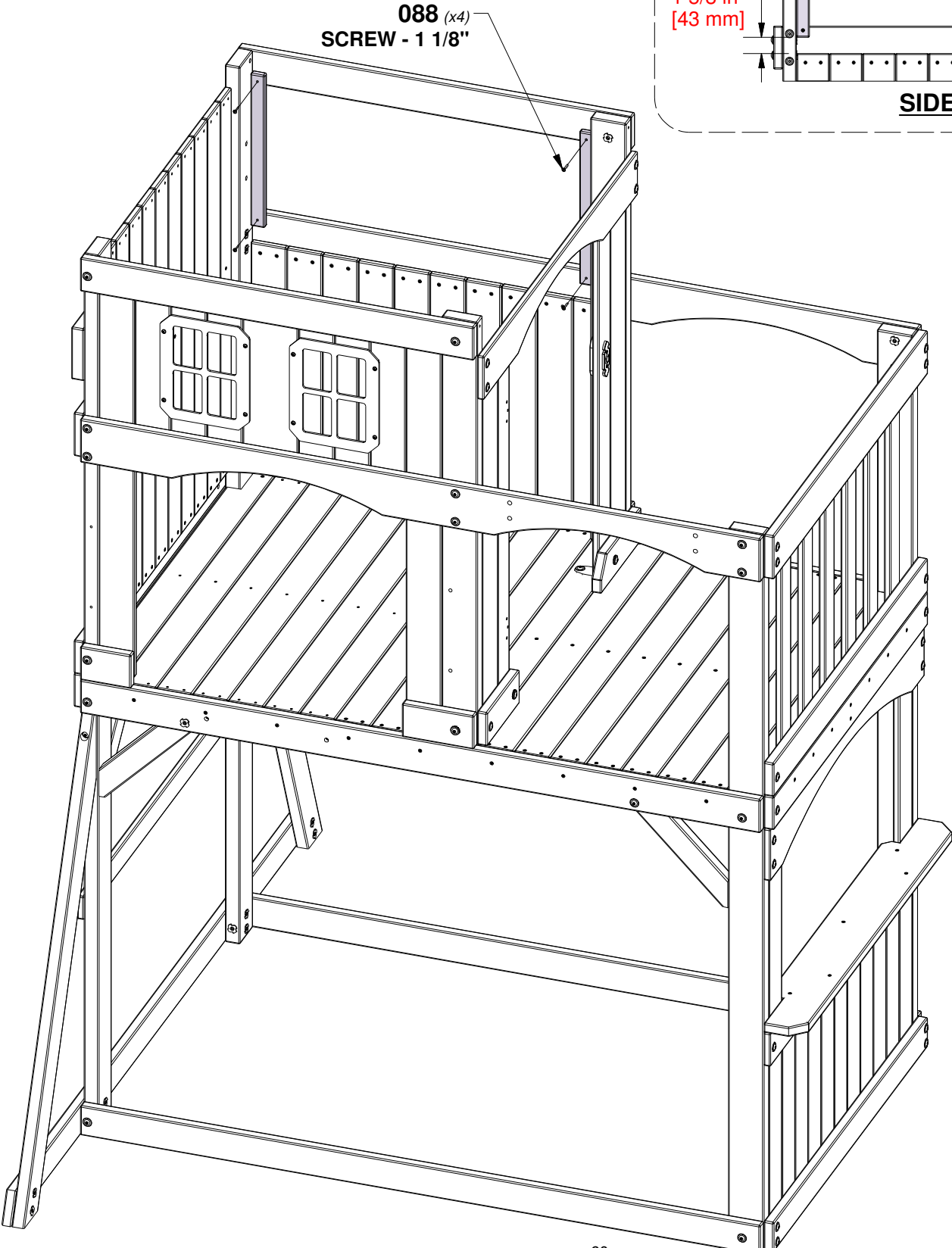
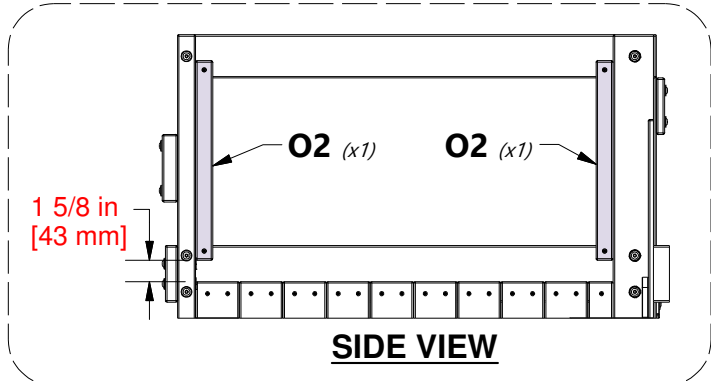

# STEP 21 - FORT ASSEMBLY

QTY	PART NUMBER	DESCRIPTION
6	H100111	SCREW PFH 8x2

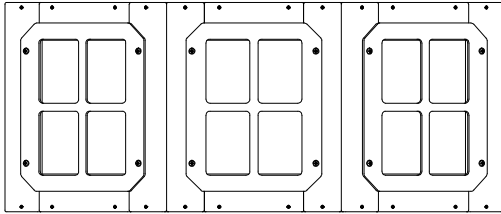

(x1) BAY WINDOW

**- PRE-DRILL USING AN 1/8" [3mm] DRILL BIT FOR HARDWARE.**

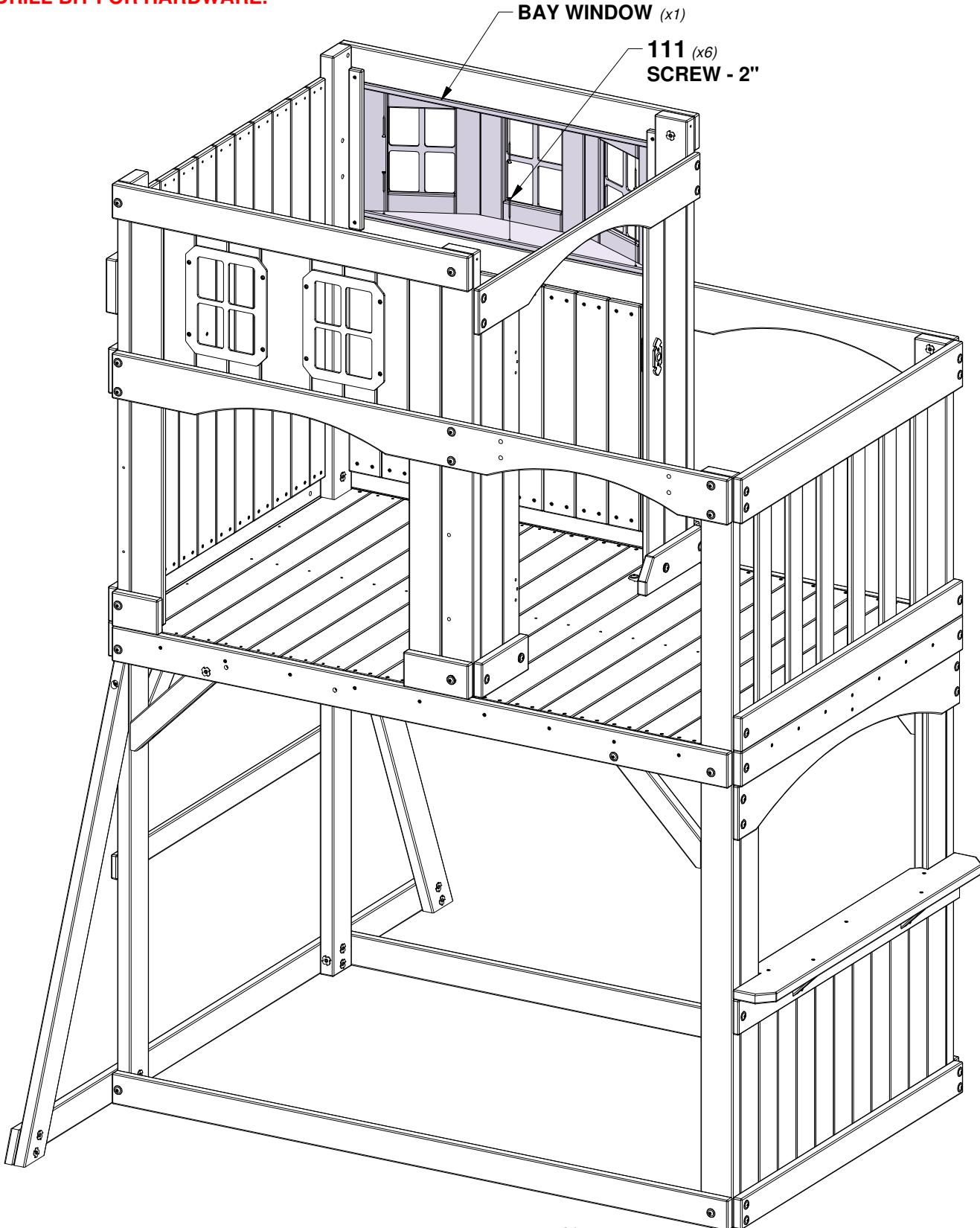

# STEP 22 - FORT ASSEMBLY

QTY	PART NUMBER	DESCRIPTION
6	H101272	NUT BARREL PPH 8x32 BLK
6	H101401	SCREW POH-MS 8/32x1/2 BLK

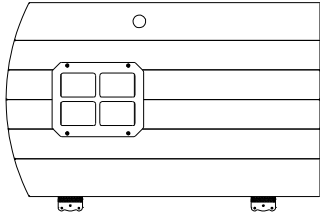

(x1) DOOR ASSEMBLY

- ALIGN HINGE WITH THROUGH HOLES

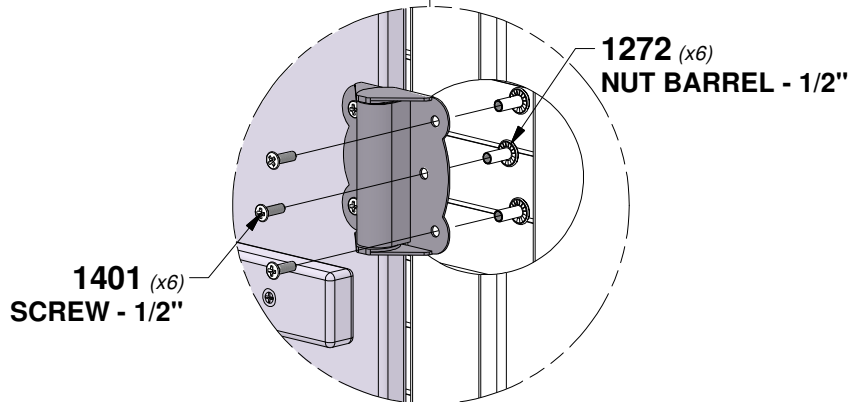
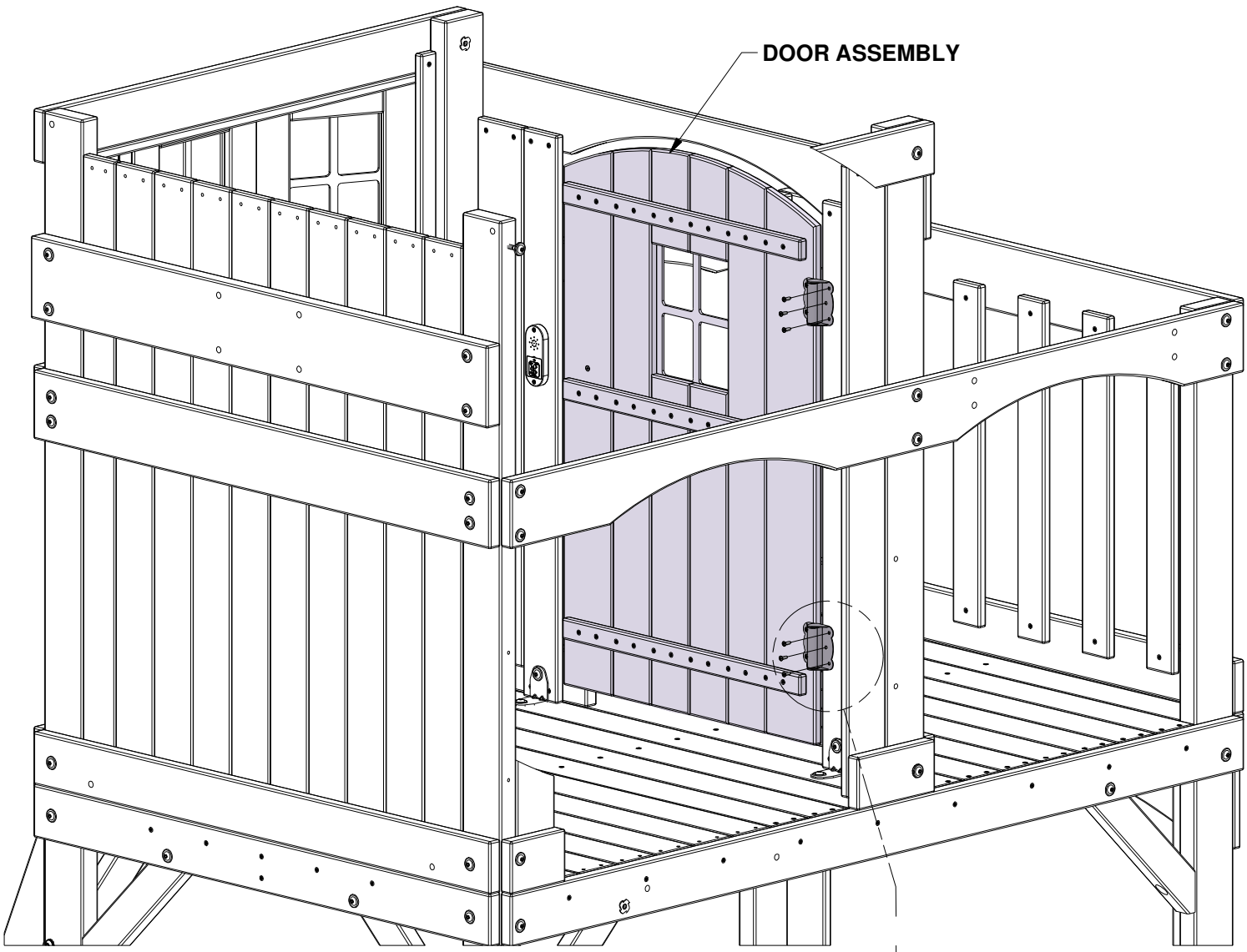

# STEP 23 - FORT ASSEMBLY

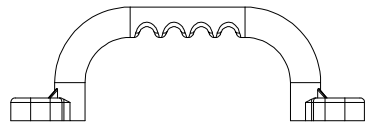

**A100028**  
*(x2)* | **HAND GRIP GREEN PLASTIC**

QTY	PART NUMBER	DESCRIPTION
2	H100398	T-NUT 1/4 BLK
2	H100403	LAG SCREW WH 1/4x1-1/2 BLK
4	H100405	WASHER LOCK EXT 6x15 BLK
2	H101026	BOLT WH 1/4x1-3/4 BLK

- INSTALL T-NUTS IN WOOD FIRST
- ALIGN PILOT HOLES

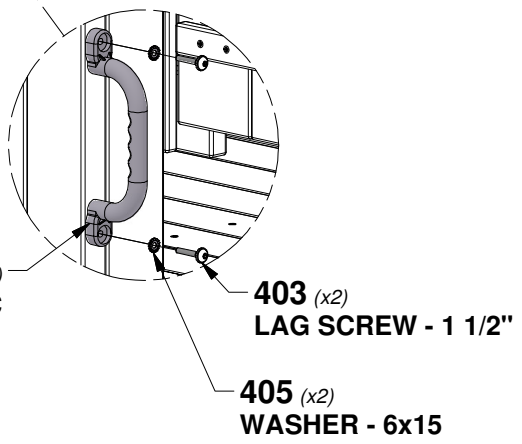
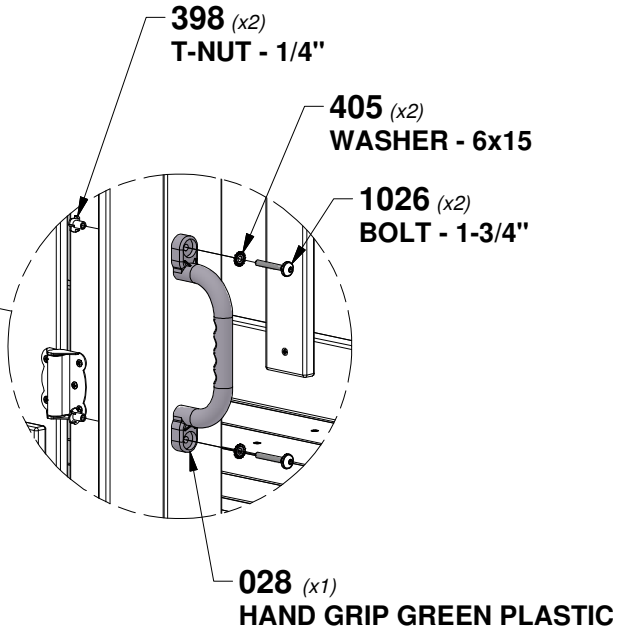
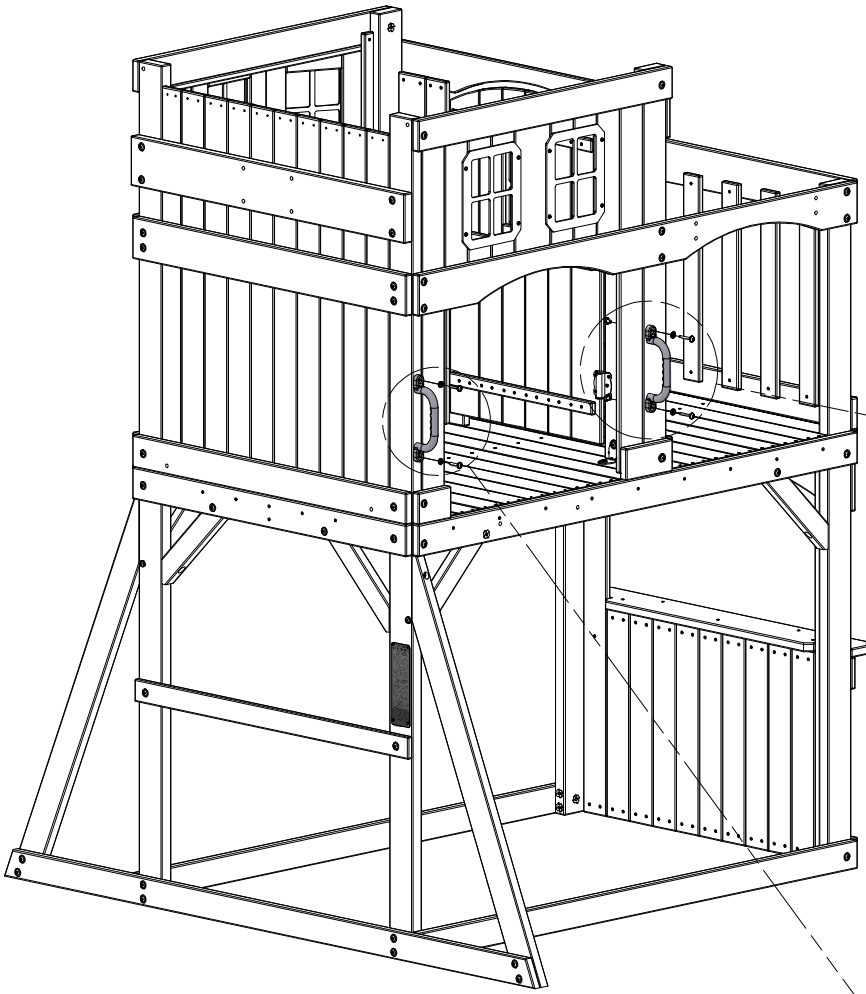

# STEP 24 - FORT ASSEMBLY

QTY	PART NUMBER	DESCRIPTION
28	H100088	SCREW PFH 8x1-1/8"
2	H100197	LAG SCREW WH 5/16x2-1/2 BLK
4	H100198	WASHER LOCK EXT 8x19 BLK
2	H100379	T-NUT 5/16 BLK
2	H100484	BOLT WH 5/16x3 1/4 BLK

**H12** WALL RAIL - W4L22697  
(x2) 1"x3 3/8"x40 3/8" (24x86x1024)

**H13** ROOF RAFTER - W4L22698  
(x4) 1"x3 3/8"x34 1/4" (24x86x871)

**M31** GABLE BOARD - W4L14599  
(x2) 5/8"x3 3/8"x31 1/2" (16x86x800)

**NOTE**  
**HOLES UPWARD**

- INSTALL T-NUTS IN WOOD FIRST
- CENTER M31 BEFORE INSTALLATION

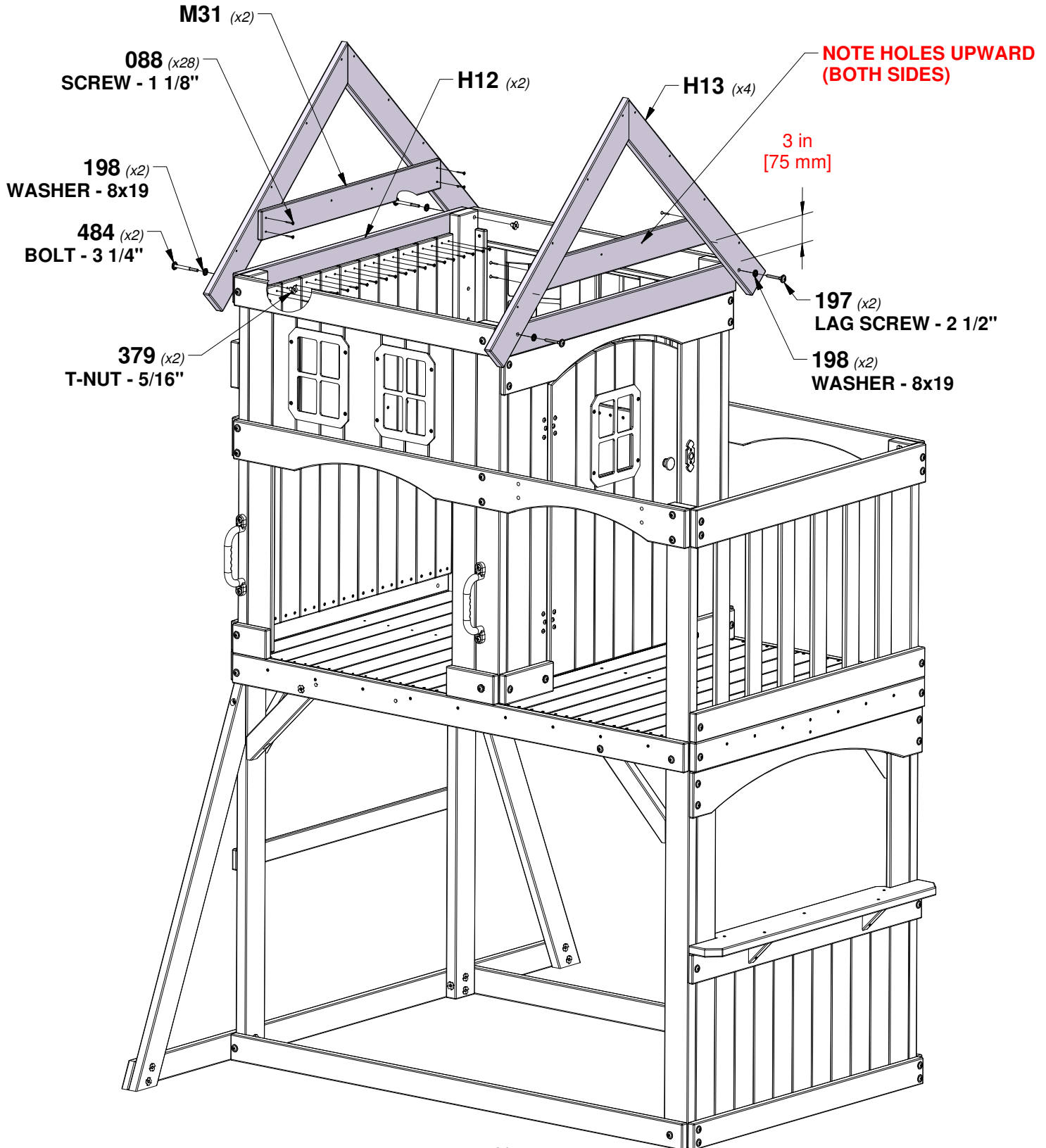

# STEP 25 - FORT ASSEMBLY

QTY	PART NUMBER	DESCRIPTION
8	H100070	SCREW PWH 8x3/4
4	H100088	SCREW PFH 8x1-1/8"

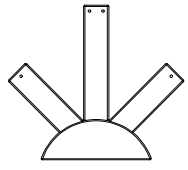

A100361 (x2) PLASTIC SUNBURST

## - ALIGN PILOT HOLES

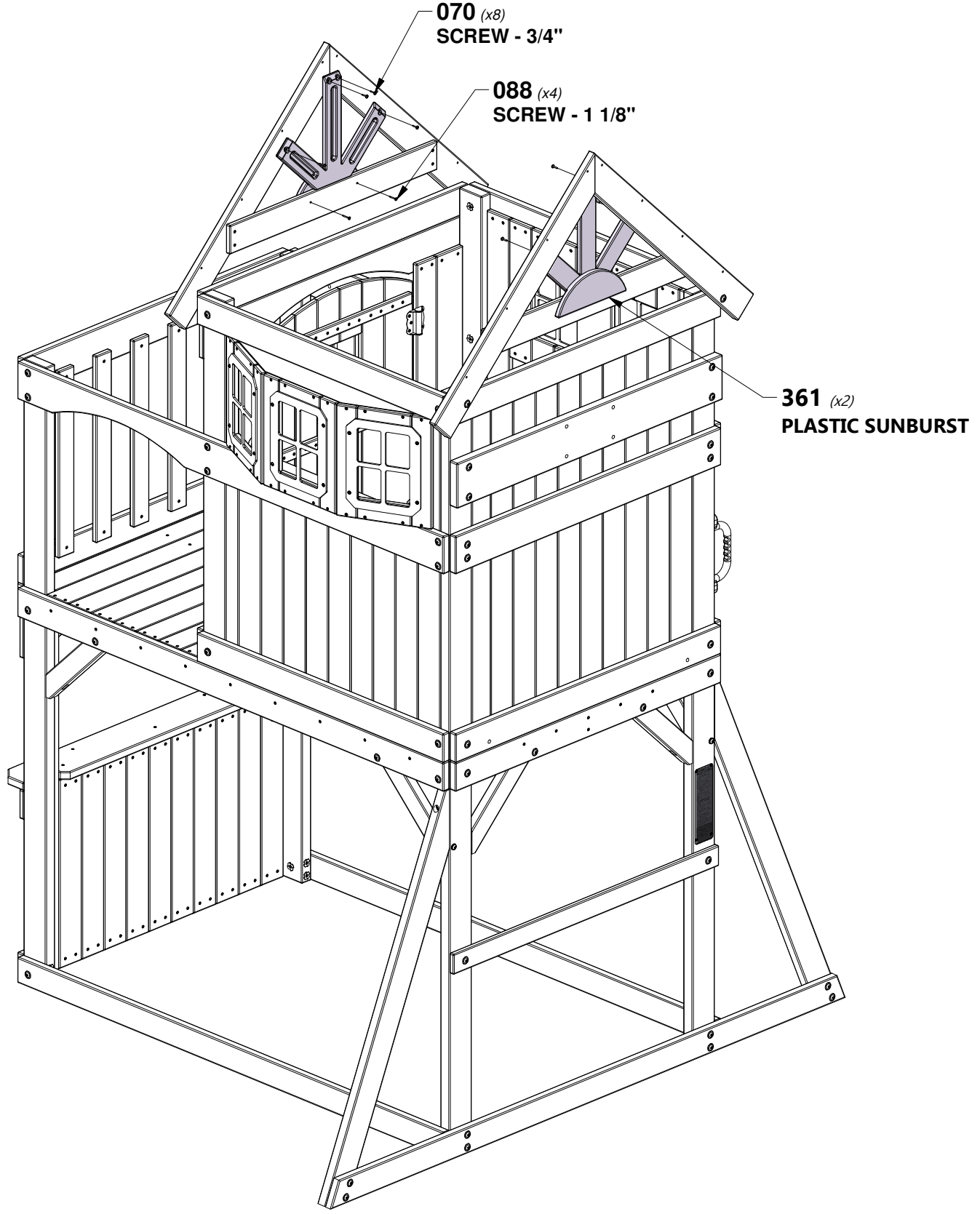

# STEP 26 - FORT ASSEMBLY

QTY	PART NUMBER	DESCRIPTION
8	H100086	SCREW PFH 8x1-1/2"

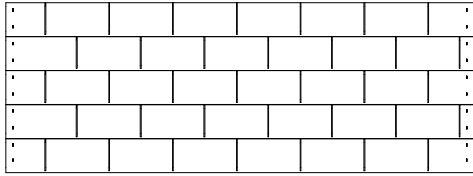

**RP2** | ROOF PANEL - W2A05152  
 (x2) | 1 3/8"x16 1/8"x42 5/8" (35x410x1115)

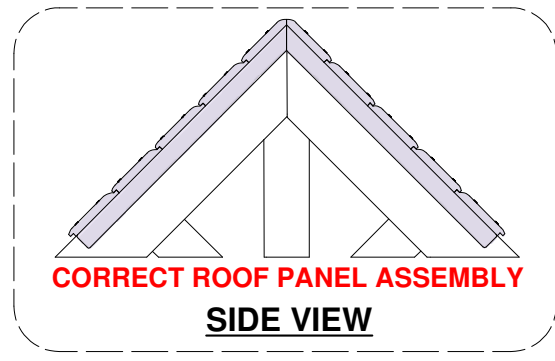
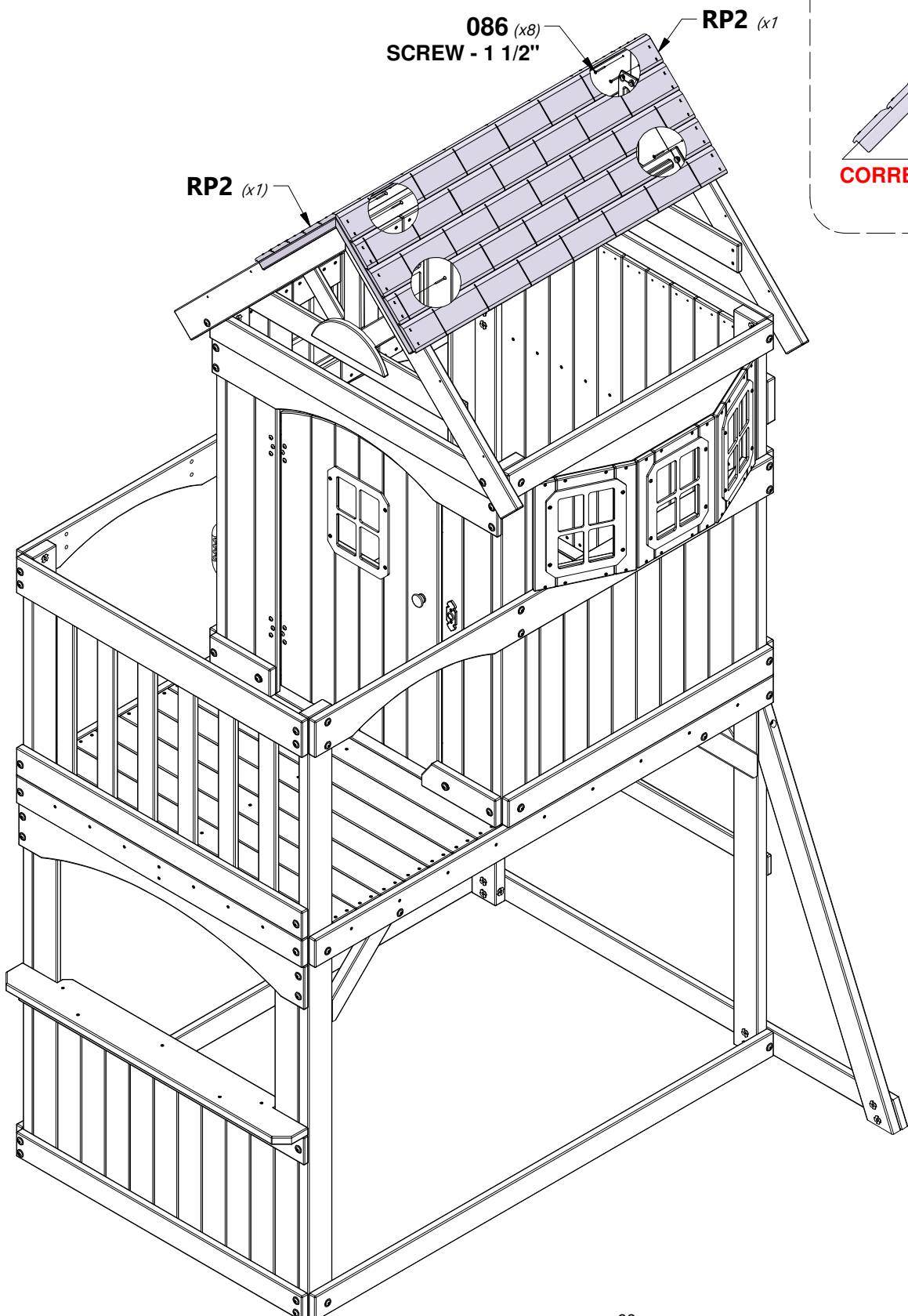

# STEP 27 - FORT ASSEMBLY

QTY	PART NUMBER	DESCRIPTION
8	H100086	SCREW PFH 8x1-1/2"

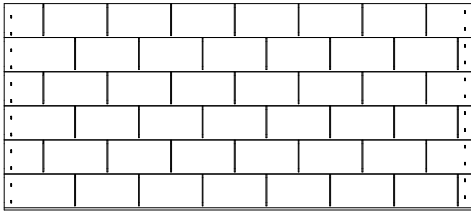

**RP1** | ROOF PANEL - W2A05151  
 (x2) | 1 3/8"x19 3/8"x42 5/8" (35x491x1115)

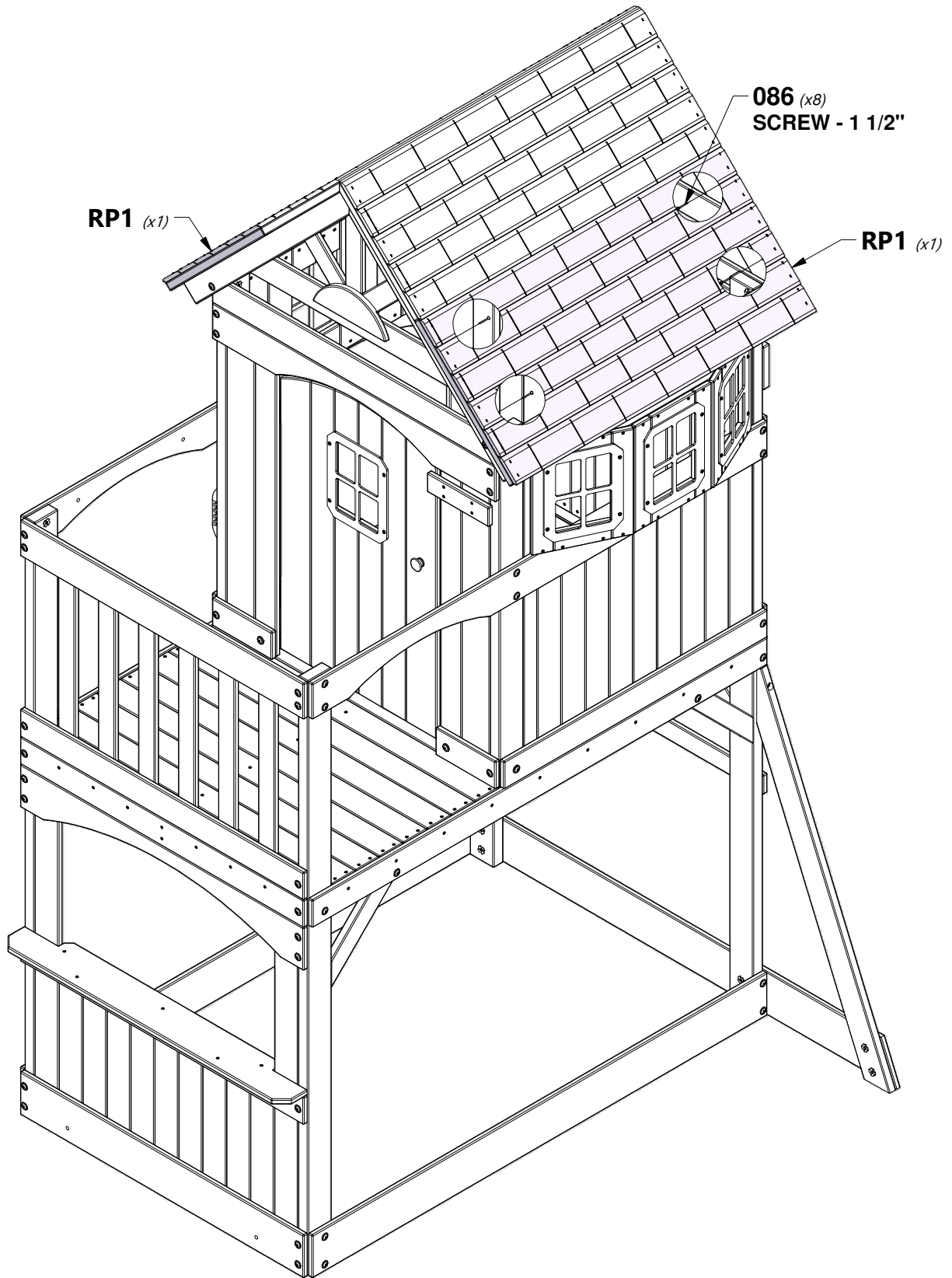

# STEP 28 - FORT ASSEMBLY

QTY	PART NUMBER	DESCRIPTION
2	H100089	SCREW PFH 8x1-3/4"
2	H100194	BOLT WH 5/16x2-1/2 BLK
2	H100198	WASHER LOCK EXT 8x19 BLK
2	H100379	T-NUT 5/16 BLK



**G2 | WALL RAIL - W4L22687**  
(x2) | 1"x4 3/8"x40 3/4" (24x112x1034)



**M34 | FILLER BOARD - W4L14617**  
(x1) | 5/8"x1 3/4"x33 1/2" (16x45x851)

**- INSTALL T-NUTS IN WOOD FIRST**

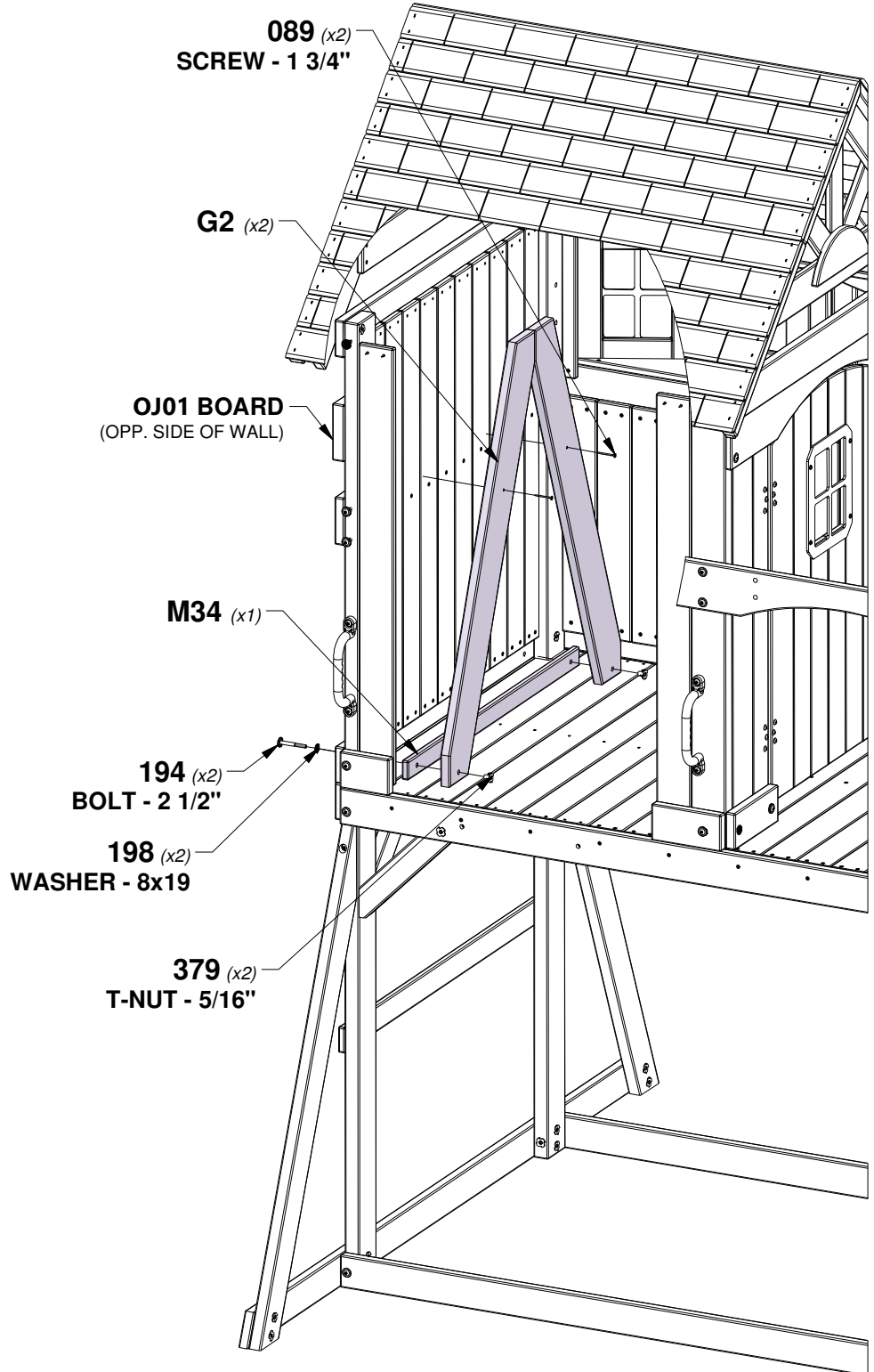
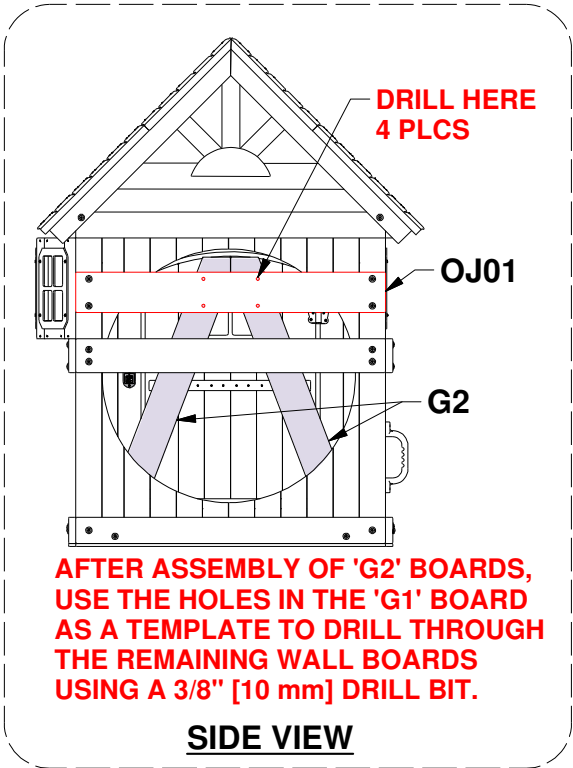

# STEP 29 - FORT ASSEMBLY

QTY	PART NUMBER	DESCRIPTION
2	H100198	WASHER LOCK EXT 8x19 BLK
2	H100378	BOLT WH 5/16x1 3/4 BLK

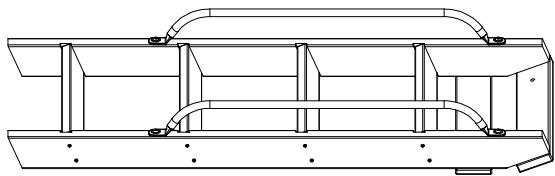

(x1) | LADDER ASSEMBLY

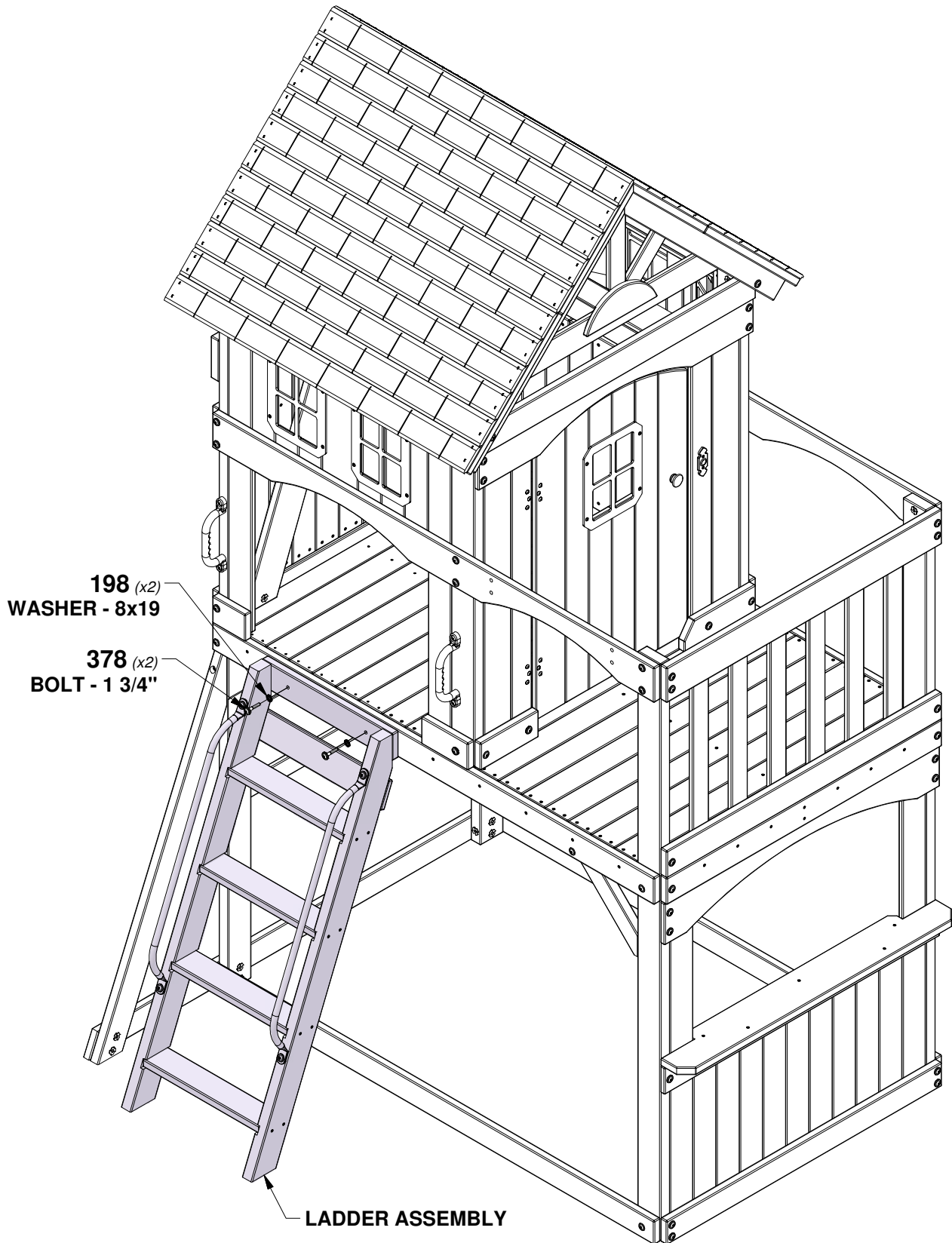

LADDER ASSEMBLY

# STEP 30 - FORT ASSEMBLY

QTY	PART NUMBER	DESCRIPTION
4	H100379	T-NUT 5/16 BLK
4	H100468	BOLT WH 5/16x1 BLK

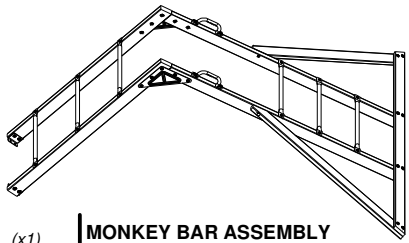

**- INSTALL T-NUTS IN WOOD FIRST**

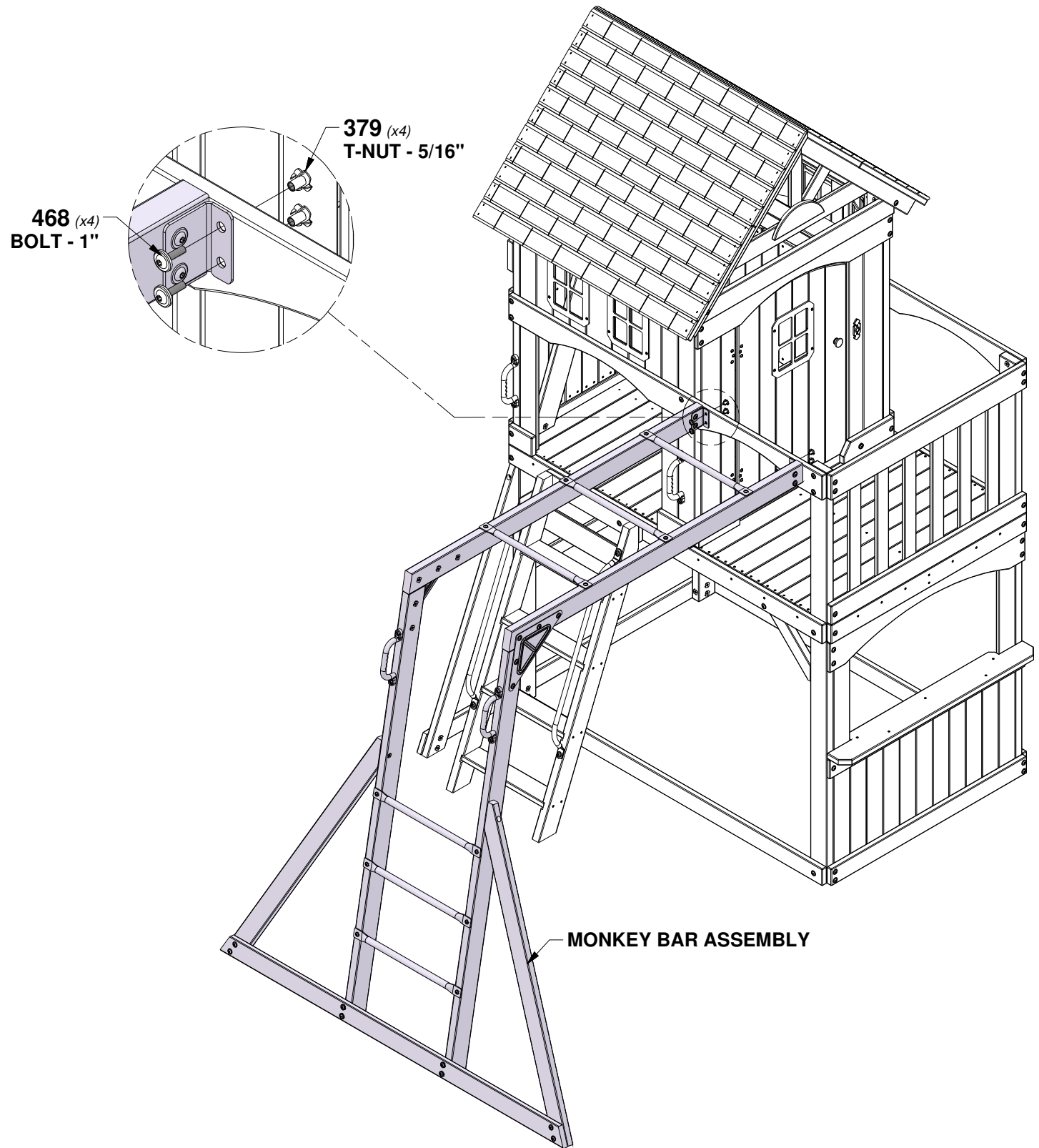

# STEP 31 - FORT ASSEMBLY

QTY	PART NUMBER	DESCRIPTION
4	H100379	T-NUT 5/16 BLK
4	H100477	WASHER SPLIT 5/16 BLK
4	H100478	WASHER FLAT 8x27 BLK
4	H100775	BOLT HEX 5/16x3 BLK

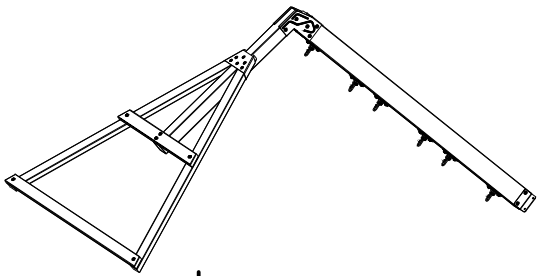

(x1) SWING BEAM ASSEMBLY

**- INSTALL T-NUTS IN WOOD FIRST**

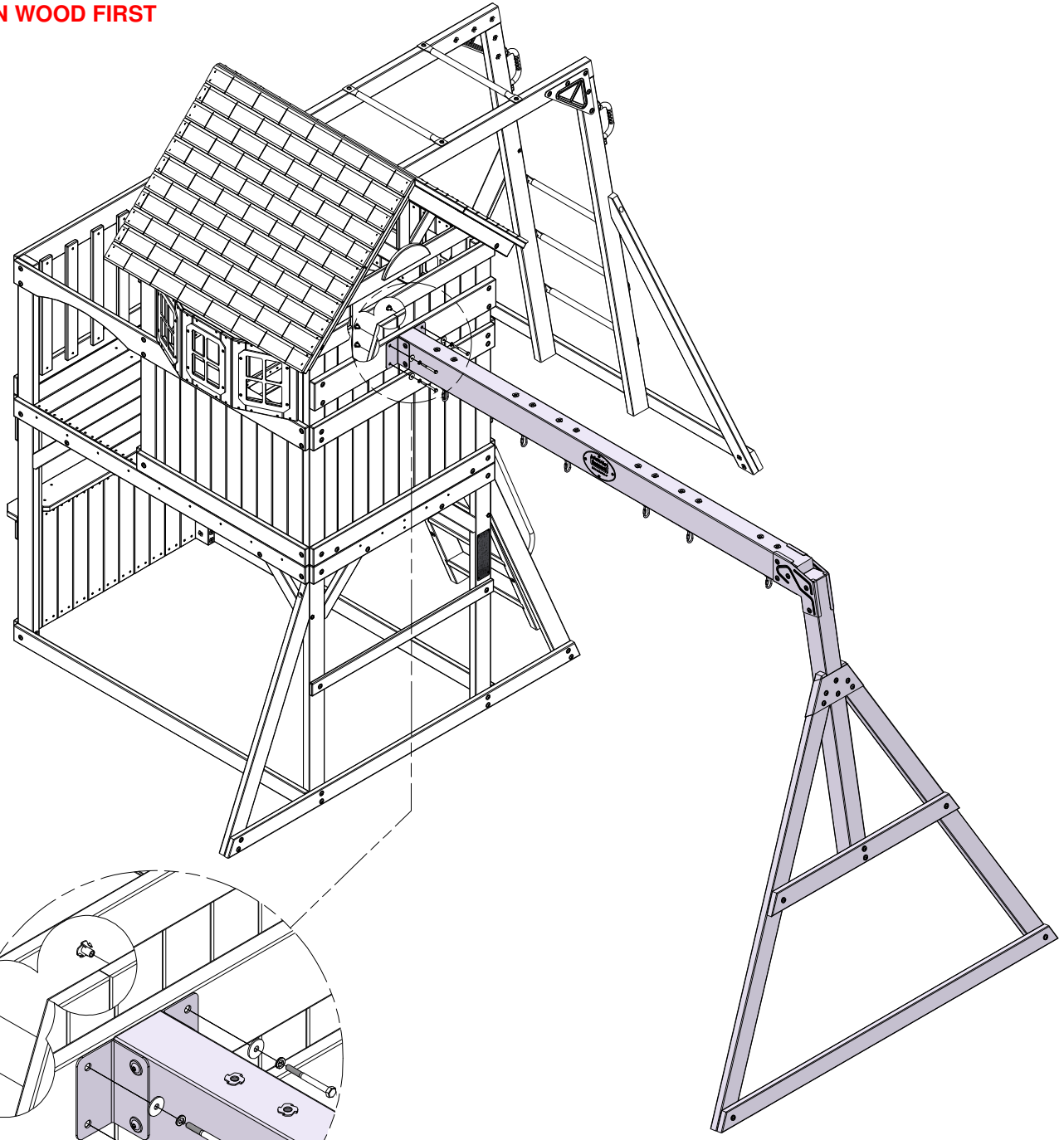

**379 (x4)**  
T-NUT - 5/16"

**478 (x4)**  
WASHER - 8x27

**775 (x4)**  
BOLT - 2-3/4"

**477 (x4)**  
WASHER - 5/16

# STEP 32 - FORT ASSEMBLY

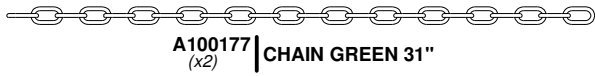

**A100177** | CHAIN GREEN 31"  
(x2)

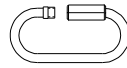

**A100069** | QUICK LINK  
(x6)

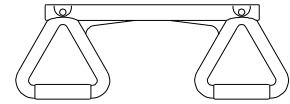

**A6P00034** | TRAPEZE YELLOW  
(x1)

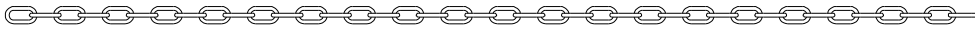

**A100068** | CHAIN GREEN 51.25"  
(x4)

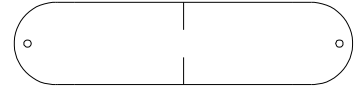

**A6P00054** | SWING SEAT GREEN 22"  
(x2)

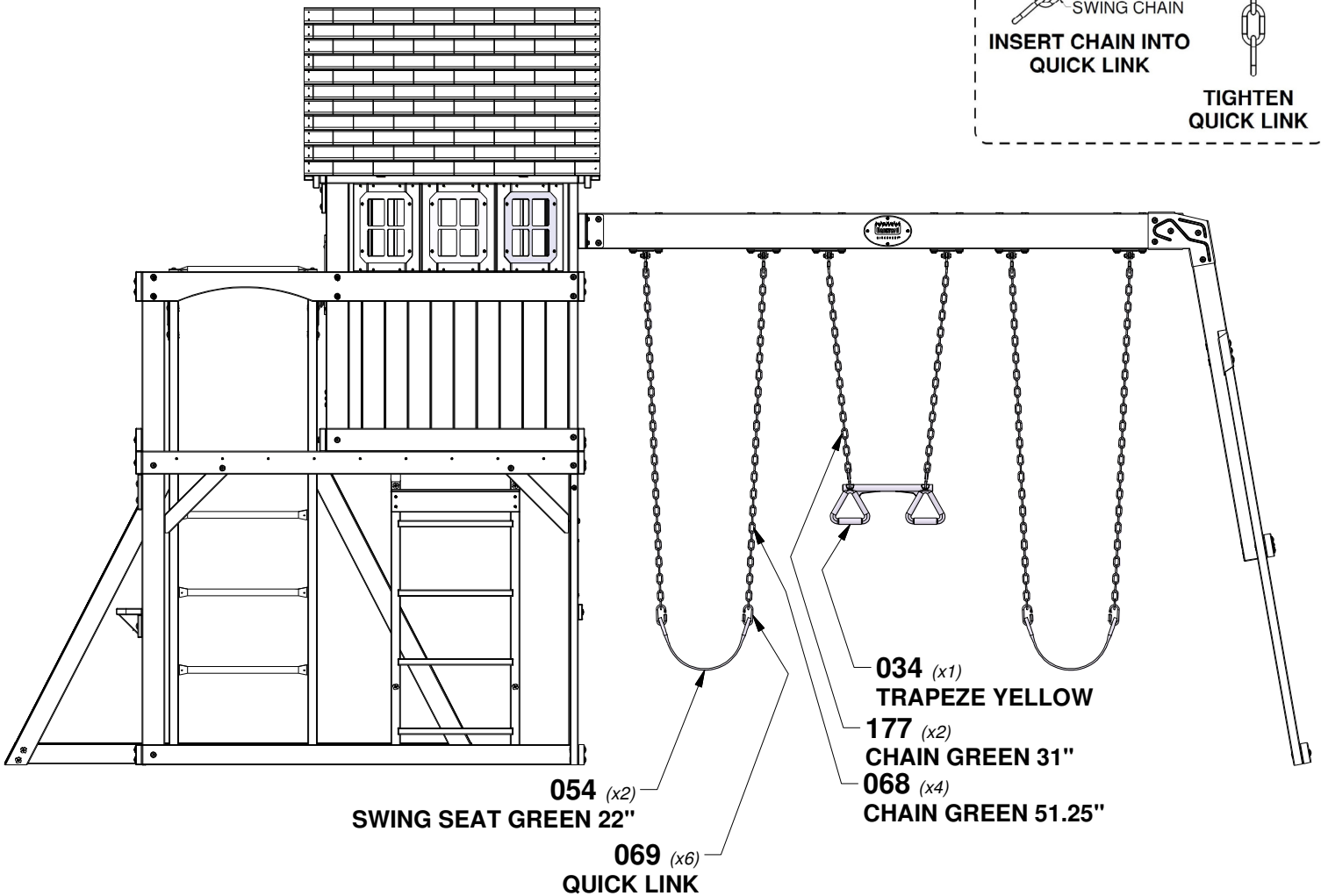
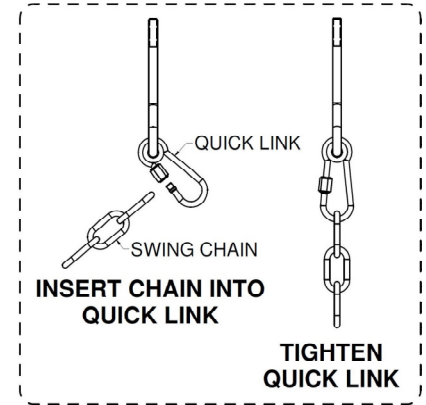

# STEP 33 - FORT ASSEMBLY

QTY	PART NUMBER	DESCRIPTION
2	H100379	T-NUT 5/16 BLK
2	H100468	BOLT WH 5/16x1 BLK

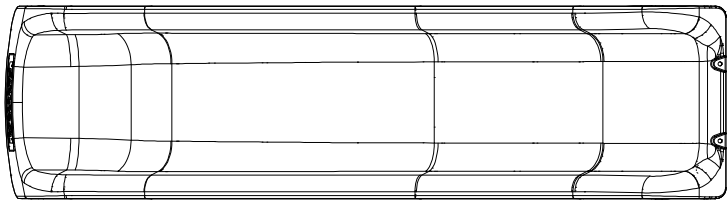

**A6P00525 (x1) 8' BLOW MOLDED SLIDE - GREEN**

**- INSTALL T-NUTS IN WOOD FIRST**

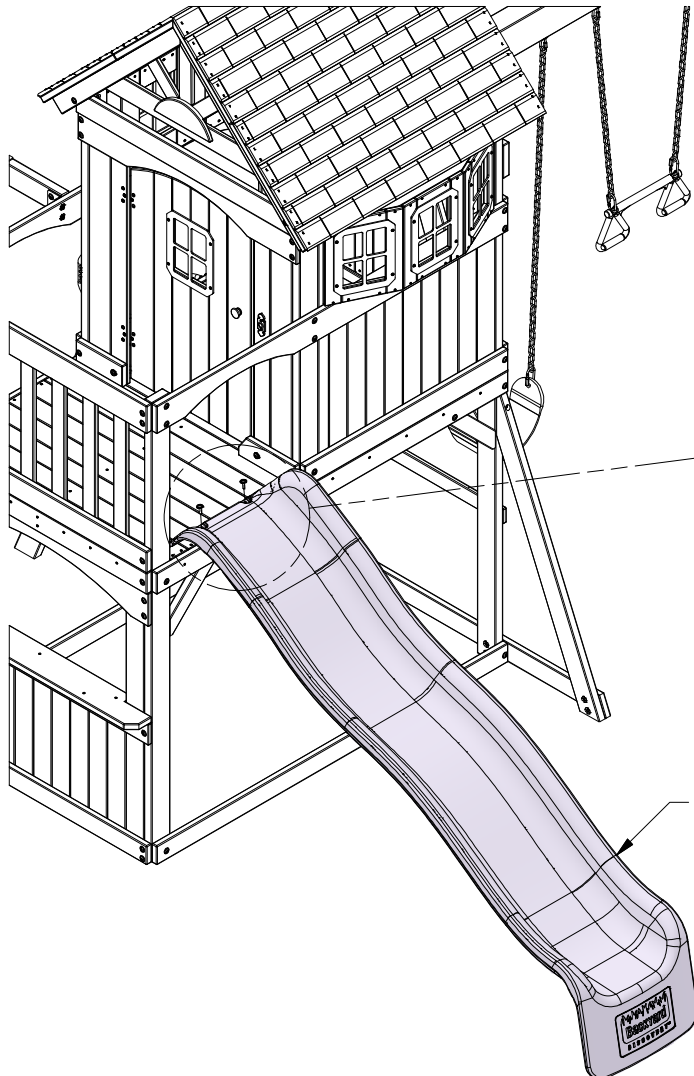
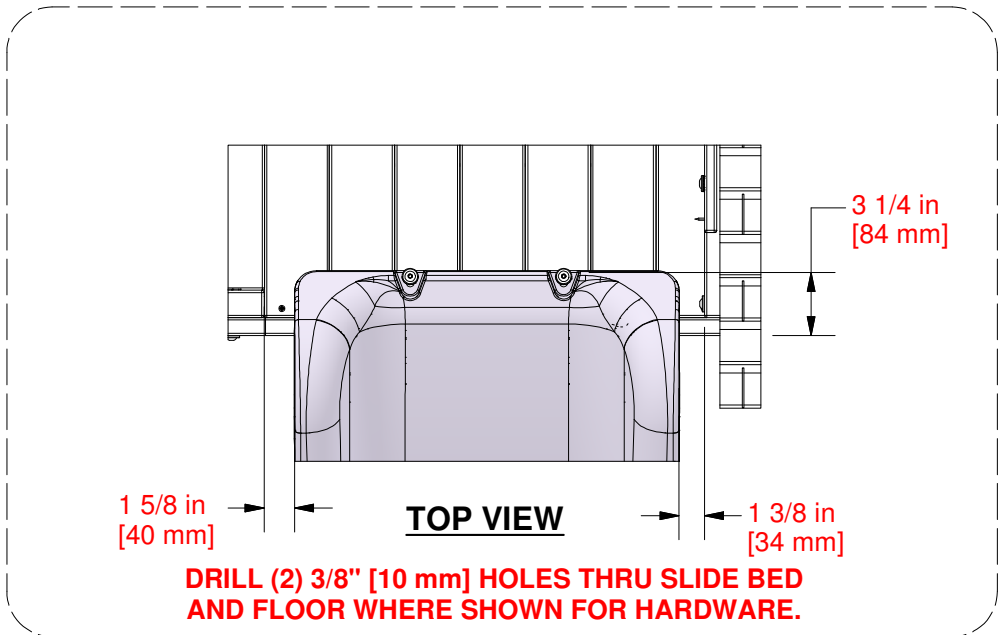

**525 (x1) 8' BLOW MOLDED SLIDE - GREEN**

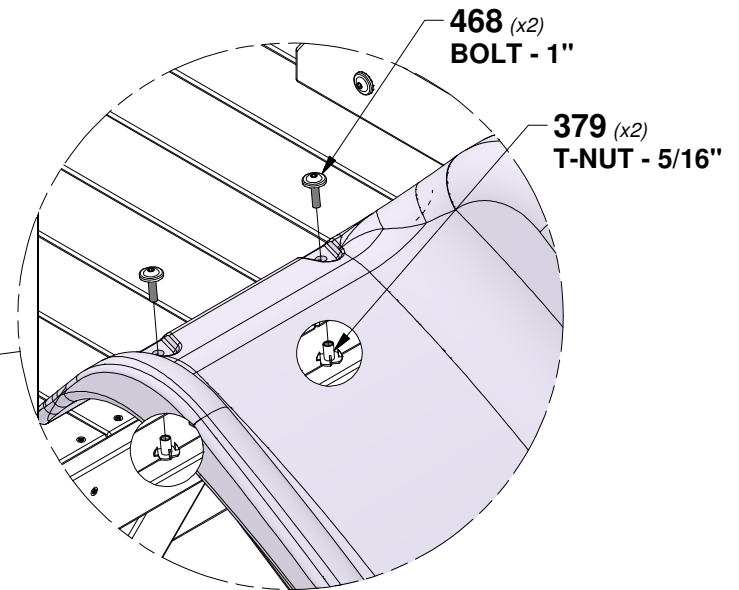

# STEP 34 - FORT ASSEMBLY

QTY	PART NUMBER	DESCRIPTION
8	H100379	T-NUT 5/16 BLK
2	H100407	BOLT WH 5/16x1 1/2 BLK
6	H100459	BOLT WH 5/16x1 1/4 BLK

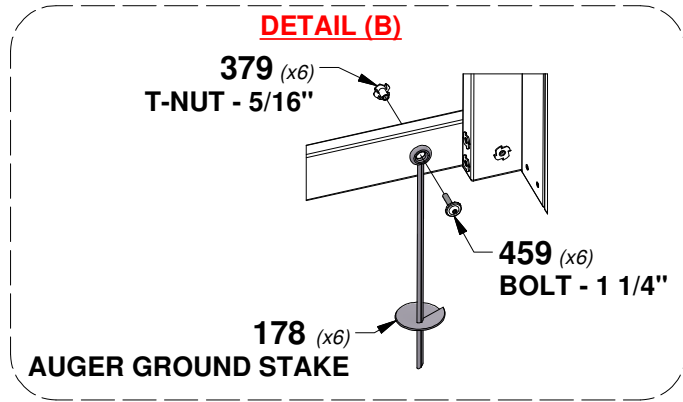

**TWIST GROUND STAKE (178) INTO GROUND AT LOCATIONS SHOWN. USING GROUND STAKE AS A GUIDE, DRILL A 3/8" [10mm] HOLE FOR HARDWARE.**

