

Hisense

USE AND INSTALLATION MANUAL

Model: HD5026TLP

**For questions about features, operation/ performance, parts or service,
call: 1-877-465-3566**

Operating hours (EST):

Monday-Friday from 9 a.m. to 9 p.m.

Saturday-Sunday from 9 a.m. to 6 p.m.

Language: English and Spanish

Table of Contents

Safety Information	2	Package Contents	7
Important Safety Instruction	2	Electrical Requirements	8
Operation	2	Location Requirements	8
Installation	3	Installation	9
Storage And Disposing Of The Unit	3	Operation	10
Precautions For Using R32 Refrigerant	3	Care and Cleaning	12
Pre-Installation	7	Troubleshooting	15

Safety Information

Your safety and the safety of others are very important. We have provided many important safety messages in this manual and on your appliance.

Please always read and obey all safety messages. To reduce the risk of fire, electrical shock or injury when using your appliance, please follow these basic precautions:

Important Safety Instruction

- Plug into a grounded 3-prong outlet.
- Do not remove ground prong.
- Do not use an electrical adapter or extension cord.
- Do not drink water discharged from the dehumidifier, it may contain mold and bacteria that can cause death if ingested.
- Unplug dehumidifier before servicing.
- If the supply cord is damaged, it must be replaced by the manufacturer, its service agent or similarly qualified persons in order to avoid a hazard.
- Keep packing materials out of the reach of children. Packaging materials can be dangerous for children. There is a risk of suffocation.
- Be careful not to pinch, crush, or damage the power cord when installing or moving the appliance.
- Do not use the appliance in standing water or allow the product to be directly splashed by water during use.
- Store and install the appliance where it will not be exposed to temperatures below freezing or exposed to outdoor weather conditions.
- Call an authorized service technician to repair or immediately replace all power cords that have become damaged. Do not use a cord that shows cracks or abrasion damage along its length or at either end.
- Do not use the product if the outlet is damaged or loose.
- In the event of a gas leak (propane gas, LP gas, etc.) do not operate this or any other appliance. Open a window or door to ventilate the area immediately.
- Do not disassemble, repair or modify the product.
- Do not store or use flammable gases or materials near the dehumidifier.

Operation

Read all instructions before using the appliance and save these instructions.

- Do not tamper with controls.
- Push the power plug all the way into the wall outlet so that it is not loose.
- Do not grasp the power cord or touch the appliance controls with wet hands.
- Do not modify or extend the power cord.
- If the product makes a strange noise or emits a smell or smoke, unplug the unit and contact customer service.
- Avoid placing the dehumidifier or other heavy objects on top of the power cord.
- Do not use water to clean the dehumidifier.
- Keep the air inlet and outlet free from obstructions.
- Do not cover the power cord with a rug or carpeting. Do not place any item on cord.
- Do not insert fingers, sticks etc. into the air inlet or outlet. The fan is running at high speeds and could cause personal injuries.
- Do not repair or replace any part of the appliance. All repairs and servicing must be performed by qualified servicing personnel unless specifically recommended in this owner's manual. Use only authorized factory parts. Connect to a properly rated, protected, and sized power circuit to avoid electrical overload.
- Do not use the product for preserving animals/plants, precision instruments, art works, etc.
- Do not place any objects on top of the dehumidifier.
- Turn off the dehumidifier and empty the water bucket before moving the dehumidifier.
- Unplug the unit if you will not be using the product for an extended period.
- Do not use the product in a very small space such as a closet. Poor ventilation could result in overheating.

Safety Information (continued)

- Do not use wax, thinner or a strong detergent when cleaning. Wipe the product using a soft cloth.
- Do not use the product outdoors.
- Position the product on a firm, stable surface.
- Remove cable ties and extend power cord before use.
- Do not spray foreign substances or water on the product.
- Please recycle or dispose of the packaging material for product in an environmentally responsible manner.
- Never store or ship the appliance upside down or sideways to avoid damage to the compressor.

All safety messages will tell you what the potential hazard is and tell you how to reduce the chance of injury.

Installation

- Use this appliance only for its intended purpose. This product is not designed for preserving precision instruments, tableware, or artwork.
- Never unplug the appliance by pulling on the power cord. Always grip the plug firmly and pull straight out from the outlet.
- Do not use the product in places where chemicals are used. Chemicals and solvents dissolved in the air could cause product deformation and leaking.
- Turn off the dehumidifier and unplug the unit before cleaning. Wait for the fan to stop moving.
- Do not operate the dehumidifier without a filter. Using the product without a filter could result in a reduced product life span, electric shock or injury.
- This appliance is not intended for use by persons (including children) with reduced physical, sensory or mental capabilities, or lack of experience and knowledge, unless they have been given supervision or instruction concerning use of the appliance by person responsible for their safety.
- Children should be supervised to ensure that they can not play with the appliance.
- The appliance shall be installed in accordance with national wiring regulations.

Storage And Disposing Of The Unit

- Dispose of this appliance in accordance with Federal and Local regulations. Refrigerants must be evacuated before disposal.

PRECAUTIONS FOR USING R32 REFRIGERANT

The basic installation work procedures are the same as the conventional refrigerant (R22 or R410A). However, pay attention to the following:

1. Transport of equipment containing flammable refrigerants

Attention is drawn to the fact that additional transportation regulations may exist with respect to equipment containing flammable gas. The maximum number of pieces of equipment or the configuration of the equipment permitted to be transported together will be determined by the applicable transport regulations.

2. Marking of equipment using signs

Signs for similar appliances used in a work area are generally addressed by local regulations and give the minimum requirements for the provision of safety and/or health signs for a work location.



All required signs are to be maintained and employers should ensure that employees receive suitable and sufficient instruction and training on the meaning of appropriate safety signs and the actions that need to be taken in connection with these signs. The effectiveness of signs should not be diminished by too many signs being placed together. Any pictograms used should be as simple as possible and contain only essential details.

3. Disposal of equipment using flammable refrigerants





See national regulations.

4. Storage of equipment/appliances

The storage of the appliance should be in accordance with the applicable regulations or instructions, whichever is more stringent.

	DANGER: A hazard that if not avoided will result in death or serious injury.
	WARNING: A hazard that if not avoided could result in death or serious injury.
	CAUTION: A hazard that if not avoided may result in minor or moderate injury.

Explanation of symbols displayed on the unit.

		A2L	WARNING This symbol shows that this appliance uses a flammable refrigerant. If the refrigerant is leaked and exposed to an external ignition source, there is a risk of fire.
			CAUTION This symbol shows that the operation manual should be read carefully.
			CAUTION This symbol shows that a service professional should be handling this equipment with reference to the installation manual.
			CAUTION This symbol shows that information is available such as the operating manual or installation manual.

Safety Information (continued)

5. Storage of packed (unsold) equipment

Storage package protection should be constructed in such a way that mechanical damage to the equipment inside the package will not cause a leak of the refrigerant charge.

The maximum number of pieces of equipment permitted to be stored together will be determined by local regulations.

6. Qualification of workers

Qualification of the working personnel for maintenance, service and repair operations should according to UL60335-2-40、CAN/C-SA-C22.2 No.60335-2-40: 22 Annex HH.

Every working procedure that affects safety means shall only be carried out by competent persons according to Annex HH. Special training additional to usual refrigerating equipment repair procedures is required when equipment with FLAMMABLE REFRIGERANTS is affected.

Examples for such working procedures are:

- breaking into the refrigerating circuit;
- opening of sealed components;
- opening of ventilated enclosures.

7. Information on servicing

Where electrical components are being changed, they shall be fit for the purpose and to the correct specification. At all times the manufacturer's maintenance and service guidelines shall be followed. If in doubt, consult the manufacturer's technical department for assistance.

The following checks shall be applied to installations using FLAMMABLE REFRIGERANTS:

- the actual REFRIGERANT CHARGE is in accordance with the room size within which the refrigerant containing parts are installed;
- the ventilation machinery and outlets are operating adequately and are not obstructed;
- if an indirect refrigerating circuit is being used, the secondary circuit shall be checked for the presence of refrigerant;
- marking to the equipment continues to be visible and legible. Markings and signs that are illegible shall be corrected;
- refrigerating pipe or components are installed in a position where they are unlikely to be exposed to any substance which may corrode refrigerant containing components, unless the components are constructed of materials which are inherently resistant to being corroded or are suitably protected against being so corroded.

Maintenance, service, and repair personnel must be trained according to UL/CSA 60335-2-40 Ed 4.0 Annex HH and possess the required qualifications.

For Models employing Flammable Refrigerant, the user instruction shall also contain the following information:

- 1). Prior to beginning work on systems containing FLAMMABLE REFRIGERANTS, safety checks are necessary to ensure that the risk of ignition is minimised.
- 2). For repair to the REFRIGERATING SYSTEM, the following shall be completed prior to conducting work on the system.
 - Work shall be undertaken under a controlled procedure so as to minimise the risk of a flammable gas or vapour being present while the work is being performed.
 - All maintenance staff and others working in the local area shall be instructed on the nature of work being carried out. Work in confined spaces shall be avoided.
 - The area shall be checked with an appropriate refrigerant detector prior to and during work, to ensure the technician is aware of potentially toxic or flammable atmospheres. Ensure that the leak detection equipment being used is suitable for use with all applicable refrigerants, i.e. non-sparking, adequately sealed or intrinsically safe.
 - If any hot work is to be conducted on the refrigerating equipment or any associated parts, appropriate fire extinguishing equipment shall be available to hand. Have a dry powder or CO2 fire extinguisher adjacent to the charging area.
 - No person carrying out work in relation to a REFRIGERATING SYSTEM which involves exposing any pipe work shall use any sources of ignition in such a manner that it may lead to the risk of fire or explosion. All possible ignition sources, including cigarette smoking, should be kept sufficiently far away from the site of installation, repairing, removing and disposal, during which refrigerant can possibly be released to the surrounding space. Prior to work taking place, the area around the equipment is to be surveyed to make sure that there are no flammable hazards or ignition risks. "No Smoking" signs shall be displayed.

Ventilated area

Ensure that the area is in the open or that it is adequately ventilated before breaking into the system or conducting any hot work. A degree of ventilation shall continue during the period that the work is carried out. The ventilation should safely disperse any released refrigerant and preferably expel it externally into the atmosphere.

Checks to the refrigerating equipment

Where electrical components are being changed, they shall be fit for the purpose and to the correct specification. At all times the manufacturer's maintenance and service guidelines shall be followed. If in doubt, consult the manufacturer's technical department for assistance.

The following checks shall be applied to installations using flammable refrigerants:

- the actual refrigerant charge is in accordance with the room size within which the refrigerant containing parts are installed;
- the ventilation machinery and outlets are operating adequately and are not obstructed;
- if an indirect refrigerating circuit is being used, the secondary circuit shall be checked for the presence of refrigerant;
- marking to the equipment continues to be visible and legible. Markings and signs that are illegible shall be corrected;
- refrigerating pipe or components are installed in a position where they are unlikely to be exposed to any substance which may corrode refrigerant containing components, unless the components are constructed of materials which are inherently resistant to being corroded or are suitably protected against being so corroded.

Repair and maintenance to electrical components shall include initial safety checks and component inspection procedures.

If a fault exists that could compromise safety, then no electrical supply shall be connected to the circuit until it is satisfactorily dealt

Safety Information (continued)

with. If the fault cannot be corrected immediately but it is necessary to continue operation, an adequate temporary solution shall be used. This shall be reported to the owner of the equipment so all parties are advised.

Initial safety checks shall include:

- that capacitors are discharged; this shall be done in a safe manner to avoid possibility of sparking;
- that no live electrical components and wiring are exposed while charging, recovering or purging the system;
- that there is continuity of earth bonding.

8. Sealed electrical components shall be replaced.

9. Intrinsically safe components must be replaced.

10. Cabling

Check that cabling will not be subject to wear, corrosion, excessive pressure, vibration, sharp edges or any other adverse environmental effects. The check shall also take into account the effects of aging or continual vibration from sources such as compressors or fans.

11. Detection of flammable refrigerants

Under no circumstances shall potential sources of ignition be used in the searching for or detection of refrigerant leaks. A halide torch (or any other detector using a naked flame) shall not be used.

12. Leak detection methods

The following leak detection methods are deemed acceptable for all refrigerant systems.

Electronic leak detectors may be used to detect refrigerant leaks but, in the case of **FLAMMABLE REFRIGERANTS**, the sensitivity may not be adequate, or may need re-calibration. (Detection equipment shall be calibrated in a refrigerant-free area.) Ensure that the detector is not a potential source of ignition and is suitable for the refrigerant used. Leak detection equipment shall be set at a percentage of the LFL of the refrigerant and shall be calibrated to the refrigerant employed, and the appropriate percentage of gas (25% maximum) is confirmed.

Leak detection fluids are also suitable for use with most refrigerants but the use of detergents containing chlorine shall be avoided as the chlorine may react with the refrigerant and corrode the copper pipe-work.



NOTE: Examples of leak detection fluids are

- bubble method,
- fluorescent method agents.

If a leak is suspected, all naked flames shall be removed/extinguished.

If a leakage of refrigerant is found which requires brazing, all of the refrigerant shall be recovered from the system, or isolated (by means of shut off valves) in a part of the system remote from the leak.

13. Removal and evacuation

When breaking into the refrigerant circuit to make repairs - or for any other purpose - conventional procedures shall be used. However, for flammable refrigerants it is important that best practice be followed, since flammability is a consideration.

The following procedure shall be adhered to:

- safely remove refrigerant following local and national regulations;
- evacuate;
- purge the circuit with inert gas (optional for A2L);
- evacuate (optional for A2L);
- continuously flush or purge with inert gas when using flame to open circuit;
- open the circuit.

The refrigerant charge shall be recovered into the correct recovery cylinders if venting is not allowed by local and national codes.

For appliances containing flammable refrigerants, the system shall be purged with oxygen - free nitrogen to render the appliance safe for flammable refrigerants. This process might need to be repeated several times. Compressed air or oxygen shall not be used for purging refrigerant systems.

For appliances containing flammable refrigerants, refrigerants purging shall be achieved by breaking the vacuum in the system with oxygen - free nitrogen and continuing to fill until the working pressure is achieved, then venting to atmosphere, and finally pulling down to a vacuum (optional for A2L). This process shall be repeated until no refrigerant is within the system (optional for A2L). When the final oxygen - free nitrogen charge is used, the system shall be vented down to atmospheric pressure to enable work to take place.

The outlet for the vacuum pump shall not be close to any potential ignition sources, and ventilation shall be available.

14. Charging procedures

In addition to conventional charging procedures, the following requirements shall be followed.

- Ensure that contamination of different refrigerants does not occur when using charging equipment.
- Hoses or lines shall be as short as possible to minimise the amount of refrigerant contained in them.
- Cylinders shall be kept in an appropriate position according to the instructions.
- Ensure that the REFRIGERATING SYSTEM is earthed prior to charging the system with refrigerant.
- Label the system when charging is complete (if not already).
- Extreme care shall be taken not to overfill the REFRIGERATING SYSTEM.

Prior to recharging the system, it shall be pressure-tested with the appropriate purging gas. The system shall be leak-tested on completion of charging but prior to commissioning. A follow up leak test shall be carried out prior to leaving the site.

Safety Information (continued)

15. Decommissioning

Before carrying out this procedure, it is essential that the technician is completely familiar with the equipment and all its detail. It is recommended good practice that all refrigerants are recovered safely. Prior to the task being carried out, an oil and refrigerant sample shall be taken in case analysis is required prior to re-use of recovered refrigerant. It is essential that electrical power is available before the task is commenced.

- a) Become familiar with the equipment and its operation.
- b) Isolate system electrically.
- c) Before attempting the procedure, ensure that:
 - mechanical handling equipment is available, if required, for handling refrigerant cylinders;
 - all personal protective equipment is available and being used correctly;
 - the recovery process is supervised at all times by a competent person;
 - recovery equipment and cylinders conform to the appropriate standards.
- d) Pump down refrigerant system, if possible.
- e) If a vacuum is not possible, make a manifold so that refrigerant can be removed from various parts of the system.
- f) Make sure that cylinder is situated on the scales before recovery takes place.
- g) Start the recovery machine and operate in accordance with instructions.
- h) Do not overfill cylinders (no more than 80% volume liquid charge).
- i) Do not exceed the maximum working pressure of the cylinder, even temporarily.
- j) When the cylinders have been filled correctly and the process completed, make sure that the cylinders and the equipment are removed from site promptly and all isolation valves on the equipment are closed off.
- k) Recovered refrigerant shall not be charged into another REFRIGERATING SYSTEM unless it has been cleaned and checked.

16. Labelling

Equipment shall be labelled stating that it has been de-commissioned and emptied of refrigerant. The label shall be dated and signed. For appliances containing FLAMMABLE REFRIGERANTS, ensure that there are labels on the equipment stating the equipment contains FLAMMABLE REFRIGERANT.

17. Recovery

When removing refrigerant from a system, either for servicing or decommissioning, it is recommended good practice that all refrigerants are removed safely.

When transferring refrigerant into cylinders, ensure that only appropriate refrigerant recovery cylinders are employed.

Ensure that the correct number of cylinders for holding the total system charge is available. All cylinders to be used are designated for the recovered refrigerant and labelled for that refrigerant (i.e. special cylinders for the recovery of refrigerant). Cylinders shall be complete with pressure-relief valve and associated shut-off valves in good working order. Empty recovery cylinders are evacuated and, if possible, cooled before recovery occurs.

The recovery equipment shall be in good working order with a set of instructions concerning the equipment that is at hand and shall be suitable for the recovery of all appropriate refrigerants including, when applicable, FLAMMABLE REFRIGERANTS. In addition, a set of calibrated weighing scales shall be available and in good working order. Hoses shall be complete with leak-free disconnect couplings and in good condition. Before using the recovery machine, check that it is in satisfactory working order, has been properly maintained and that any associated electrical components are sealed to prevent ignition in the event of a refrigerant release. Consult manufacturer if in doubt.

The recovered refrigerant shall be processed according to local legislation in the correct recovery cylinder, and the relevant waste transfer note arranged. Do not mix refrigerants in recovery units and especially not in cylinders.

If compressors or compressor oils are to be removed, ensure that they have been evacuated to an acceptable level to make certain that flammable refrigerant does not remain within the lubricant. The compressor body shall not be heated by an open flame or other ignition sources to accelerate this process. When oil is drained from a system, it shall be carried out safely, servicing shall be performed only as recommended by the manufacturer.



A2L

WARNING:

Risk of Fire or Explosion.

This unit contains flammable refrigerant.

Additional safety precautions must be followed.



1. Do not use means to accelerate the defrosting process or to clean, other than those recommended by the manufacturer.
2. The appliance shall be stored in a room without continuously operating ignition sources (for example: open flames, an operating gas appliance or an operating electric heater).
3. Do not pierce or burn refrigerant tubing. Be aware that refrigerants may not contain an odor.
4. Compliance with national gas regulations shall be observed.
5. Keep ventilation openings clear of obstruction. The maximum refrigerant charge amount is shown on nameplate on the air conditioner.
6. When handling, installing, and operating the appliance, care should be taken to avoid damage to the refrigerant tubing.
7. Do not drill holes in the unit.
8. Dispose of air conditioner in accordance with Federal and Local Regulations. Flammable refrigerants require special disposal procedures.
9. Contact your local authorities for the environmentally safe disposal of your air conditioner.
10. The appliance shall be stored so as to prevent mechanical damage from occurring.
11. The appliance shall be stored in a well-ventilated area where the room size corresponds to the room area as specified for operation.
12. This product contains small parts such as (batteries, battery cover and screws) that may cause suffocation if swallowed by children.

Pre-Installation

Package Contents

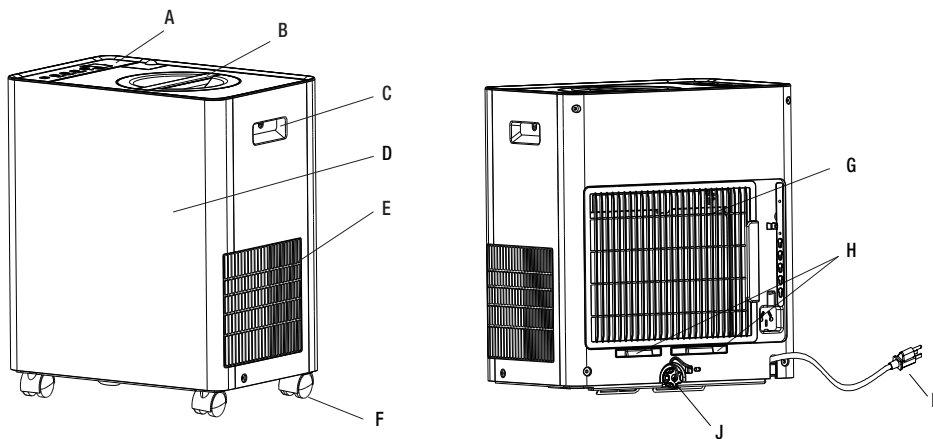

Part	Description
A	Control panel
B	Water bucket handle
C	Handle (both sides)
D	Front panel
E	Air outlet grille
F	Caster
G	Air filter
H	Water filters
I	Power plug
J	Drain cover
K	User manual



Accessories

Caster (4 pc)



Drain hose (1 pc)



Water Pipe Fitting Parts (1 pc) (installed in drain hose)



Pre-Installation (continued)

Electrical Requirements

Specific electrical requirements are listed in the chart below. Follow the requirements for the type of plug on the power supply cord.

WARNING:



- Plug into a grounded 3-prong outlet.
- Do not remove ground prong.
- Do not use an adapter.
- Do not use an extension cord.
- Failure to follow these instructions can result in death, fire, or electrical shock.

Recommended Grounding Method

This dehumidifier must be grounded. This dehumidifier is equipped with a power supply cord with a three-prong grounding plug. The cord must be plugged into a properly grounded three-prong outlet, grounded in accordance with all local codes and ordinances. If a properly grounded outlet is not available, it is the customer's responsibility to have a properly grounded three-prong outlet installed by a qualified electrician.

Customer's Responsibility

- To contact a qualified electrician.
- To assure that the electrical installation is adequate and conforms to the national electrical code. ANSI/NFPA 70-last edition, and all local codes and ordinances.

Copies of the standards listed may be obtained from:

National Fire Protection Association

1 Batterymarch Park

Quincy, MA 02169-7471

www.nfpa.org

Wiring Requirement

Power supply	Time-delay fuse (or circuit breaker)
115V 103.5V min. 126.5V max.	15A

Location Requirements



WARNING: To reduce the risk of injury to persons, malfunction, or damage to the product or property when using this appliance, follow basic safety precautions, including the following:

- Do not use outdoors. This dehumidifier is intended for indoor, residential use only. This dehumidifier is not recommended for commercial use.
- The dehumidifier allows at least 12 to 18 inches (30.5 cm to 45.7 cm) of space, as shown on the right, for good air circulation.
- You will need a surface strong enough to support the dehumidifier when its bucket is full of water.
- You will need a surface level enough to keep the water from spilling when the bucket is full of water.
- Do not block the air outlet of the unit.
- Never operate this dehumidifier in an area that is likely to accumulate standing water. If this condition develops, for your safety disconnect the power supply before stepping into the water.

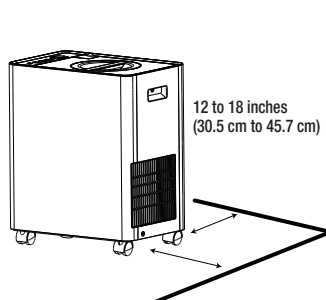

Installation

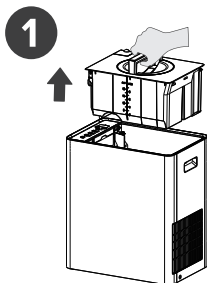

Pull out the bucket.

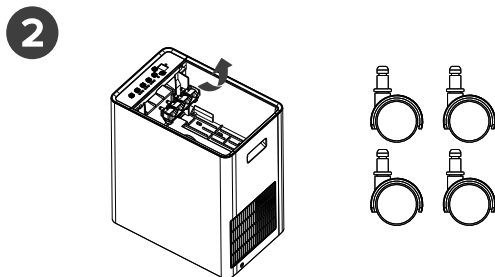

Remove the four casters from the compartment located beneath the control panel.

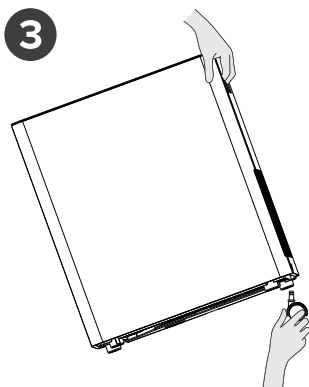

Tilt the unit on its side and hold it with one hand, then insert four casters.

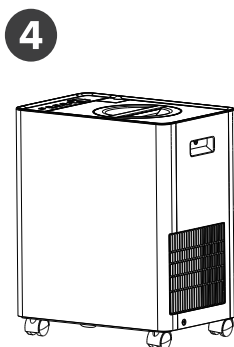

Complete the installation.

NOTE:



- Take out the bucket before installing casters.
- The tilt angle is not to exceed 30 degrees when installing casters.
- All casters must be installed within 5 minutes.
- After the caster installation is complete, set the unit upright and rest for 30 minutes before starting the unit.

Operation

- Before turning on the dehumidifier, be sure that the bucket is empty and fits all the way into the dehumidifier.
- Each time you unplug the dehumidifier or power is interrupted, the controls will return to the previous settings when power is restored.
- Humidity displayed is between 30% and 90% relative humidity.
- Humidity can be set between 30% and 80% relative humidity.
- It's important to set the desired humidity level to an achievable setting. To ensure energy-efficient operation, only use the dehumidifier in a closed space, with no open windows or other sources of moist air (to avoid continuous running).
- Operating temperature is between 38°F to 90°F (3.2°C to 32.2°C). At temperatures of 38°F (3.2°C) or less, water freezes inside the product. At temperatures over 90°F (32.2°C), the internal temperature of the product trips a protective device which deactivates the product to avoid product damage.
- The compressor has a 3-minute delay before restarting. If the product is stopped and immediately restarted, to protect the compressor there is a 3-minute delay until the compressor restarts.
- When the dehumidifier is operating, the indoor temperature will rise. The dehumidifier does not have a cooling/heating function. Heat is generated during operation, so the room temperature may be increased by about 6°F (3°C) depending on the usage conditions (indoor temperature, size of the room).



NOTE: In the event of a power failure, your dehumidifier will operate at the previous settings when the power is restored.

1 Using the Control Panel



POWER
CONNECT 3 Sec

POWER ON OR OFF

- Press POWER to turn on or off the dehumidifier.
- **CONNECT:** Press and hold the POWER button for 3 seconds to enter the WiFi pairing mode. For more details, please refer to the instructions in the app.



NOTE: Wi-Fi control is available for connected models with this logo on the control panel.



MODE

DESIRED HUMIDITY MODE

- Press and release MODE until you see the symbol for the desired humidity setting. Operating modes are Auto Dry, Continuous or Manual Set.
- Auto
- Auto Dry - The dehumidifier will operate in dry mode only. The fan speed is set automatically. The desired humidity is set to 50% automatically.
- Cont.
- Continuous - The dehumidifier will operate continuously. The fan speed can be adjusted. The desired humidity can not be adjusted.
- Manu.
- Manual Set - The dehumidifier will operate at the selected fan speed to the set humidity level. If the humidity level of the room is higher than the desired humidity setting, the compressor will turn on. If the humidity level of the room is lower than the desired humidity setting, the compressor will turn off, as well as the fan.



NOTE: The de-icing function will turn off the compressor if a low temperature condition occurs. When the de-icer senses the correct operating temperature the compressor will cycle back on. Some freezing is normal when dehumidifiers are used at low temperatures.

Operation (continued)

Empty Bucket



EMPTY BUCKET LIGHT

If this light is on, the fan and the compressor will stop running. This light indicates that you need to check:

- If the bucket is full, empty and re-install bucket. If the bucket is not in position, remove the bucket and re-install it. Make sure the bucket fits all the way into the dehumidifier and the bucket light is off, or dehumidifier will not run.



FAN

- High
- Med
- Low

FAN SPEED

- Press FAN to select fan speed. Choose HIGH, MED or LOW.
- HIGH - Will more quickly reach the desired humidity setting.
- MED - Reach the desired humidity setting with normal sound level.
- LOW - Reach the desired humidity setting with lower sound level.



NOTE: Once the relative humidity of the room hits the desired setting, the compressor will stop and the fan will turn off periodically. The fan may periodically turn on, to read the humidity level, without the compressor running.

HUMIDITY LEVEL

- Press the Plus or Minus button to set the desired humidity level. Desired humidity in the digital display will flash for 5 seconds after operation.
- Actual room humidity will be displayed after 5 seconds of flashing the desired humidity.



NOTE: Humidity can only be adjusted manually in Manual Set mode. In Continuous and Auto Dry mode, humidity level is set automatically.



DIGITAL DISPLAY

Display shows relative humidity or time (depending on setting).

- When the dehumidifier operates in Manual Set mode, the display shows the relative humidity of the room.
- When the timer is selected, the display shows the time when the dehumidifier will turn on or turn off, depending on the setting.



TIMER

To set Timer for a 30-minute to 24-hour delay before the dehumidifier is turned off (the dehumidifier must be On):

- Press TIMER. Timer indicator light will come on, and the display will flash.
- Press the Plus or Minus button to change the delay time, from 30 minutes to 24 hours.

To set Timer to turn on the dehumidifier, with previous setting:

- Turn off the dehumidifier.
- Press TIMER. Timer indicator light will flash.
- Press the Plus or Minus button to change the delay time, from 30 minutes to 24 hours.

To clear the Timer delay program:

- Press TIMER once after it has been programmed. Display will show remaining time. While the display is showing the remaining time, press TIMER again. Timer indicator light will turn off.

To see the remaining time:

- Press TIMER once after it has been programmed. Display will show remaining time.



NOTE: Empty the water bucket before setting the timer function. If the water bucket becomes full during the Timer function, the Empty Bucket light goes on and dehumidification stops.

- Press the timer in the power-on state, the timer indicator will light up and the display will flash. The ambient humidity will be restored after 5 seconds of the timer shutdown time. Press the timer in standby mode, the timer indicator light will light up and the display will flash. After 5 seconds of displaying the timed power-on time, the display turns off.



TIMER

Operation (continued)



CLEAN FILTER

- When the Clean Water Filter indicator light is on, remove, clean and replace the Water filter. See "Cleaning the Water Filter".
- When the Clean Air Filter indicator light is on, remove, clean and replace the Air filter. See "Cleaning the Air Filter".
- Press the Filter button to reset the filter monitor.



NOTE: When the Water Filter light is on, it will remain on until you press Clean Filter button.
When the Air Filter light is on, it will remain on for 180 hours or until you press Clean Filter button.

2 Normal Sounds

When your dehumidifier is operating normally, you may hear sounds such as:

- Air movement from the fan.
- Clicks from the thermostat cycling.
- A high-pitched hum or pulsating noise caused by the high-efficiency compressor cycling on and off.

3 Using the ConnectLife APP (WI-FI compatible product only)

The ConnectLife app by Hisense provides you the ability to conveniently monitor the unit and change your settings from anywhere.

DEVICES REQUIRED TO USE THE SMART FUNCTIONS:

- Smart phone with compatible iOS or Android system.
- Wireless router (a 2.4 GHz network is required to connect).
- Smart dehumidifier.

DOWNLOAD AND INSTALL THE CONNECTLIFE APP

- Scan to download the ConnectLife APP.
- You can also go to Google Play or App Store and search for the ConnectLife APP.
- Follow the in-app instructions to pair your appliance.



Care and Cleaning



WARNING: Sickness Hazard

Do not drink water collected in water bucket. Doing so can result in sickness.



IMPORTANT: If the Empty Bucket light comes on, the dehumidifier will not operate. The bucket may need to be emptied or re-installed.

NOTE:

- If the water bucket is removed immediately after turning off the dehumidifier, the water remaining in the heat exchanger may drip inside the water bucket storage area. Wipe away the water with a soft cloth.
- While cleaning, do not touch the water level float.
- Clean the water bucket once a week during use.
- If the ambient temperature is low, there is less moisture in the air for the product to remove.
- Unplug the product before removing the water bucket. If the bucket is removed while the product is operating, the compressor will stop.



1 Draining the Dehumidifier - Bucket Draining

If a floor drain is not available, or you do not plan to run your dehumidifier continuously, you may want to simply empty the bucket.

- Pull up the handle and lift the bucket slowly vertically.
- Pour the water out.

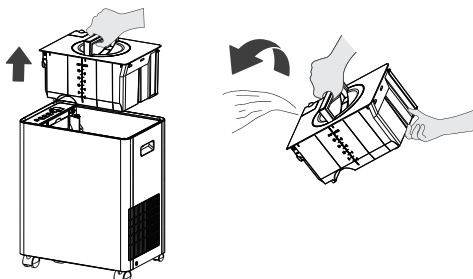

2 Pump Draining (models with a pump)

This feature can help to pump water with drain hose. You can also pump water to a floor drain, out a window or anywhere you think suitable.

- Open the drain outlet. Then, insert the drain hose through the water drain outlet. Securely attach the hose to be sure there is no water leak.
- Lead the drain hose to the floor drain or a suitable drainage facility.
- The hose should not be kinked or pinched. If this problem occurs, the unit may stop and display the error code "EB". See "Troubleshooting".
- If you want to unplug the drain hose, you need to press and hold the tightening dark gray ring of drainage joint then pull out the drain hose horizontally. (as shown as Fig. A).

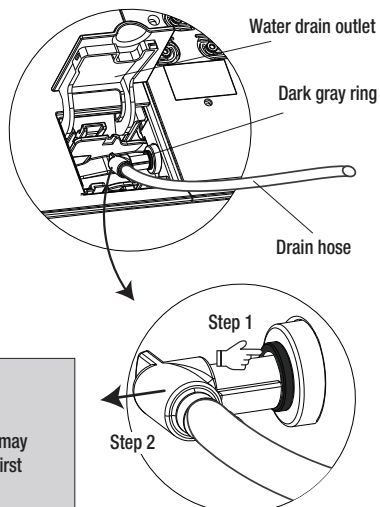

Fig. A

NOTE:

- The bucket must be properly positioned before connecting the drain hose. If the bucket is not in place, the dehumidifier will not work.
- Once the drain hose is connected, the bucket cannot be lifted out, as this may damage the hose connector. If you need to remove the bucket, you must first disconnect the drain hose.



3 Cleaning the Air Filter

The removable air filter helps clean dust, lint, and other particles from the air. Keeping it clean is essential for the best performance and efficiency of your dehumidifier.

Filter Cleaning Reminder

- After the fan has run for a total of 360 hours, the Air Filter indicator light will turn on.
- This timer is not reset by a power outage.
- Once active, the light will remind you every time the unit is turned on until it is reset.

How to Reset the Reminder

- You can reset the reminder in either of these two ways:
- Manual Reset: Press the "Filter" button once.
- Automatic Reset: If the filter is cleaned regularly every 180 hours of fan operation, the system will reset itself.
- After a successful reset, the filter light will turn off and the fan's run-time timer will be cleared.

How to Clean the Air Filter

- Turn off and unplug the dehumidifier.
- Remove the air filter by pulling it outward from the unit.
- Use a vacuum cleaner to remove dust.
- If it is very dirty, you can wash it gently in warm water with a mild detergent.
- Air dry the filter completely.
- Reinstall the clean, dry filter back into the unit.



NOTE: Do not wash air filter in the dishwasher or use any chemical cleaner. Air dry filter completely before reinstalling to ensure maximum operating efficiency.

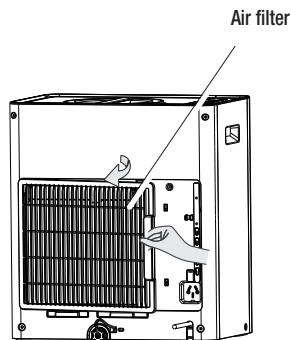

4 Cleaning the Water Filter

Filter Maintenance & Reset

Filter Cleaning Reminder

- After the pump runs for a total of 30 hours, the "Water" indicator light will turn on.
- This timer is not reset by a power outage.
- Once active, the light will remind you every time the unit is turned on until it is reset.

How to Reset the Reminder

- Press the Filter button.
- The "Water" light will turn off, and the pump's run-time timer will be cleared.

Pull out the drain cover before cleaning the water filter.

How to Drain Collected Water

- Unscrew the drain cover.
- Remove the water plug to empty the water.
- Tilt the machine slightly to ensure all water drains out.
- Once empty, securely reinstall the water plug and drain cover.

How to Clean the Water Filter

- Turn off and unplug the dehumidifier and drain the collected water.
- Remove the water filters by pulling it straight up.
- Gently wash the filter in warm water with a mild detergent.
- Let the filter air dry completely before reinstalling it.



NOTE: If the error code EB appears, it is possible that the water filter is clogged and it is necessary to clean the filter.

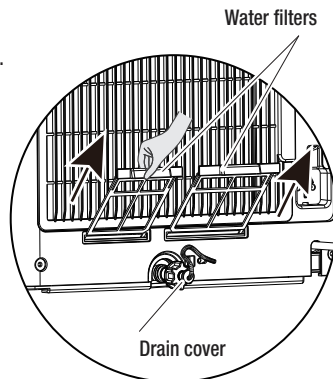

5 Cleaning the Exterior

- Turn off the dehumidifier and unplug the power supply cord.
- Dust the surface of the unit with a soft cloth or the dusting attachment of your vacuum cleaner.

6 Cleaning the Water Bucket

- Every week, rinse the inside of the water bucket with a mild detergent to avoid growth of mold, mildew and bacteria.
- As shown in the picture on the right, open the lid of the water tank with both hands.

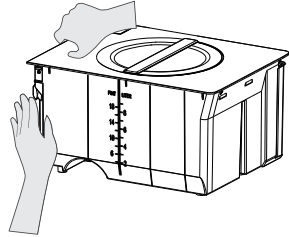

- **Water level float**

The dehumidifier has an EMPTY BUCKET light and a water level float.

Do not damage or remove the bucket's water level float. The bucket must be laid flat properly for the water level float and the EMPTY BUCKET light to work.

If the float is not positioned correctly, the Empty Bucket light will turn on, the unit will not operate, and water leakage may occur.

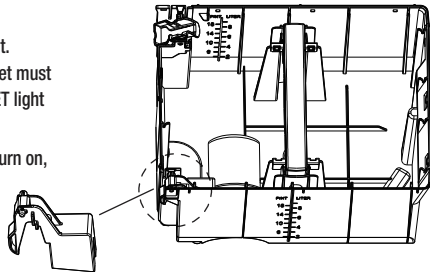

Water level float

Troubleshooting

Before calling for service, please try the suggestions below.

Problem	Solution
Dehumidifier will not operate	<p style="text-align: center;">DANGER: ELECTRICAL SHOCK HAZARD</p> <div style="display: flex; align-items: center;">  <ul style="list-style-type: none"> <input type="checkbox"/> Plug into a grounded 3-prong outlet. <input type="checkbox"/> Do not remove ground prong. <input type="checkbox"/> Do not use an adapter. <input type="checkbox"/> Do not use an extension cord. <input type="checkbox"/> Failure to follow these instructions can result in fire, electrical shock, or death. </div> <ul style="list-style-type: none"> <input type="checkbox"/> The dehumidifier is turned off. Turn on the dehumidifier. <input type="checkbox"/> The power supply cord is unplugged. Plug into a grounded 3-prong outlet. See "Pre-Installation". <input type="checkbox"/> A household fuse has blown, or a circuit breaker has tripped. Replace the fuse, or reset the circuit breaker. See "Electrical Requirements". <input type="checkbox"/> The bucket is not installed correctly. Reinstall the bucket so that it fits all the way into the dehumidifier. <input type="checkbox"/> The bucket needs to be emptied. Empty the bucket. <input type="checkbox"/> The water level float is not in place. Remove the bucket. Make sure the float is snapped in place. Reinstall the bucket. <input type="checkbox"/> The dehumidifier suddenly stopped operating and won't turn on. Confirm the power is connected, and the bucket is in place. If the unit still doesn't operate, call Hisense for Warranty service.
Dehumidifier runs but does not dehumidify	<ul style="list-style-type: none"> <input type="checkbox"/> All models have an automatic de-icing function that will shut off the compressor and allow the fan to run. When the de-icing function senses the correct operating temperature, the compressor will cycle back on. <input type="checkbox"/> The filter is dirty or obstructed with debris. Clean the filter. <input type="checkbox"/> The compressor of dehumidifier might be in Protection mode. Please check if there is something blocked the air intake and outlet, or ambient temperature is over 90 °F (32.2 °C).
Air coming from the dehumidifier is warm	<ul style="list-style-type: none"> <input type="checkbox"/> Dehumidifier will put out warm air under normal operating conditions.
Display error code	<ul style="list-style-type: none"> <input type="checkbox"/> If the unit displays error code EB, please check if the hose is kinked or pinched and clean the water filter. <input type="checkbox"/> If the unit displays other error codes, please contact customer service.

2497479-03