



LEATHER
VENTURE

ITEM 9664E Leather Sectional

Your furniture purchase is an investment. Here are a few tips to maximize the lifetime of your furniture with a minimum amount of effort. Properly caring for your furniture can help ensure that it looks great year after year.

An Introduction to your new leather upholstery

Here are a few properties of leather that create its appeal

- Leather adapts to the ambient temperature of its environment and to your own body temperature.
- Leather is less hot or cold as compared to "leather-like" manmade materials.
- leather is naturally fire proof-it does not support a flame if the origin of the flame is removed from the leather.
- Leather is naturally durable and resistant to tears.
- Leather will age and reach patina finish - Natural oils from your hair, skin and pets will add a luster to the leather and is not a quality issue.
- Leather Venture Furniture Leather is made from bovine hides, each one a unique article and has natural markings of the animals environment that give the leather is "one of a kind" look - these healed scars, natural wrinkles or other such markings help to signify your upholstery item as a real leather possession.

Care For Your Leather Venture Furniture

- Avoid placing your leather under or near direct sunlight to avoid fading.
- Keep the leather item away from heat sources that may dry out the natural oils and finish.
- Regularly dust off the leather item (when you dust your wood furniture, dust your leather) with a soft, dry cloth.
- Spots or stains can easily be cleaned using a lightly damp cloth. Mild soap can be used, if necessary. Leather cleaners are available and can be used on stubborn areas (be sure to read and follow all product instructions and test a hidden area before using).
- Do not rub the soiled area. Use light, circular motions; working towards the center of the spot or stain.
- Dry immediately after the treatment or cleaning with a dry soft cloth (preferably white so as not to transfer any color onto the leather).

Our Inside Story







Leather Venture Furniture is designed, developed and built to last. Using the latest manufacturing technologies, the frames, foam, seating suspension and other components are assembled to meet our stringent quality specifications. Frames are cut from furniture grade laminated and solid wood materials with re-inforced, glued joints then completely wrapped in fiber and/or foam to protect the leather and fabric. Our seat foam is high density polyurethane cores wrapped in fiber.

LIMITED WARRANTY

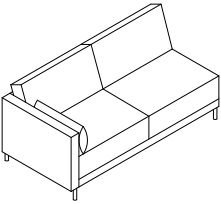
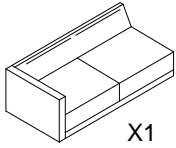
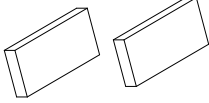
Frame, Seat and Back Suspension - 3 years
Cushioning and Leather - 1 Year

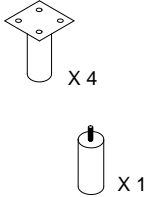
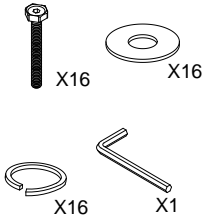
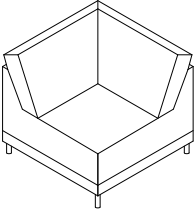
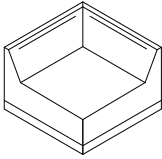
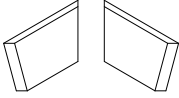
See full warranty for complete details on our website

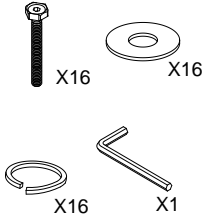
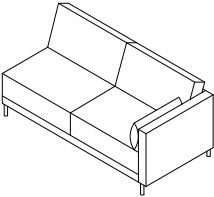
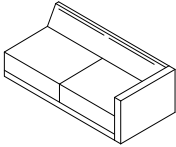
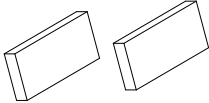
ITEM 9664E PARTS LIST

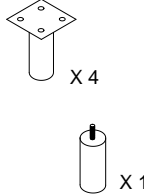
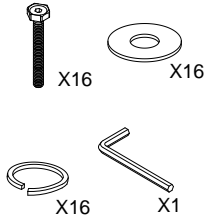
<p>LAF SOFA</p> 	<p>Seat</p>  <p>X1</p>	<p>Back Cushion</p>  <p>X2</p>	<p>Toss Pillow</p>  <p>X1</p>	<p>Leg</p>  <p>X 4 X 1</p>	<p>Hardware</p>  <p>X16 X16 X16 X1</p>
<p>CORNER CHAIR</p> 	<p>Seat</p>  <p>X1</p>	<p>Back Cushion</p>  <p>X2</p>		<p>Leg</p>  <p>X 4</p>	<p>Hardware</p>  <p>X16 X16 X16 X1</p>
<p>RAF SOFA</p> 	<p>Seat</p>  <p>X1</p>	<p>Back Cushion</p>  <p>X2</p>	<p>Toss Pillow</p>  <p>X1</p>	<p>Leg</p>  <p>X 4 X 1</p>	<p>Hardware</p>  <p>X16 X16 X16 X1</p>

ASSEMBLY INSTRUCTIONS

STEP1 Install legs

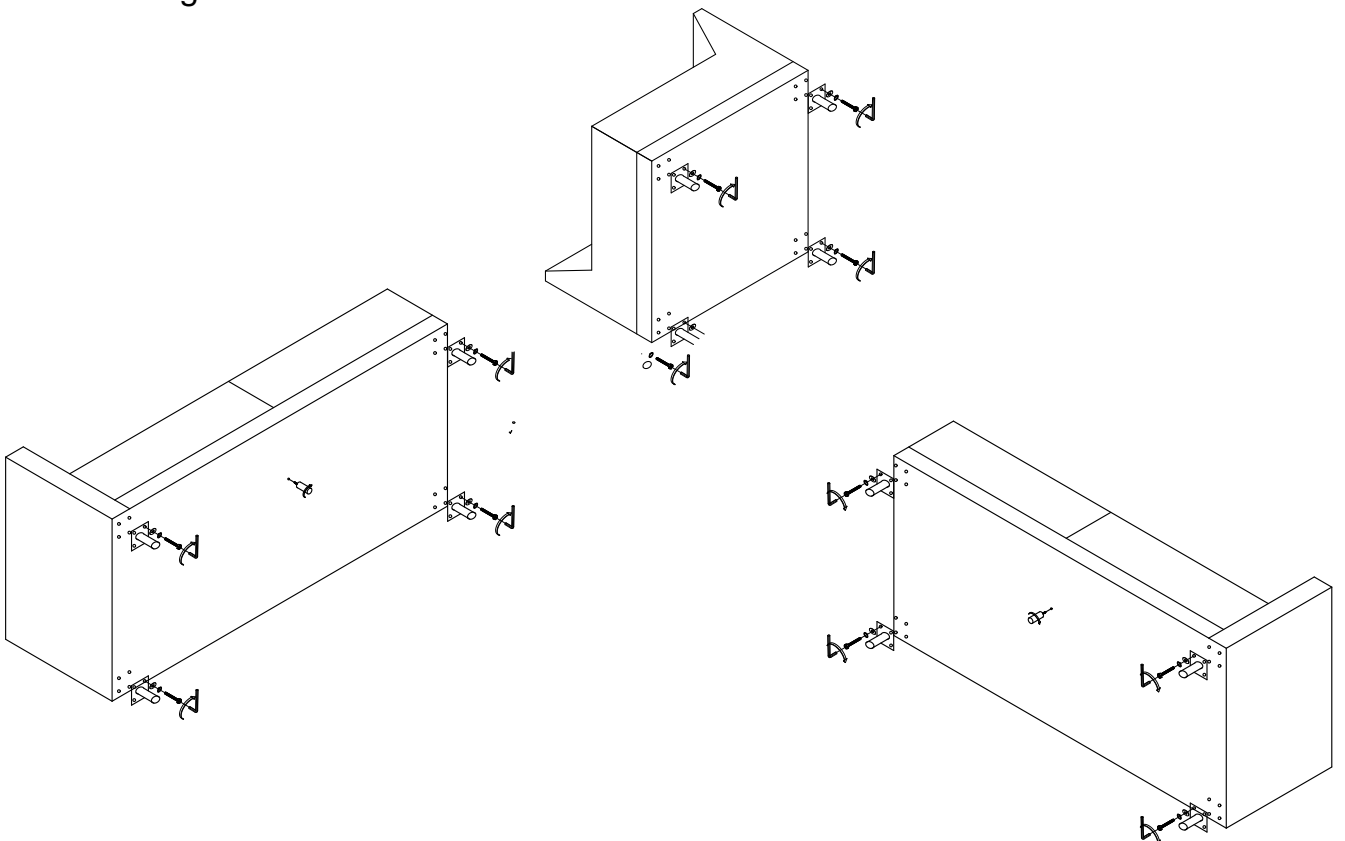

ASSEMBLY INSTRUCTIONS

STEP2 Attach back cushions to sofa by zipper and put toss pillows at inside arms

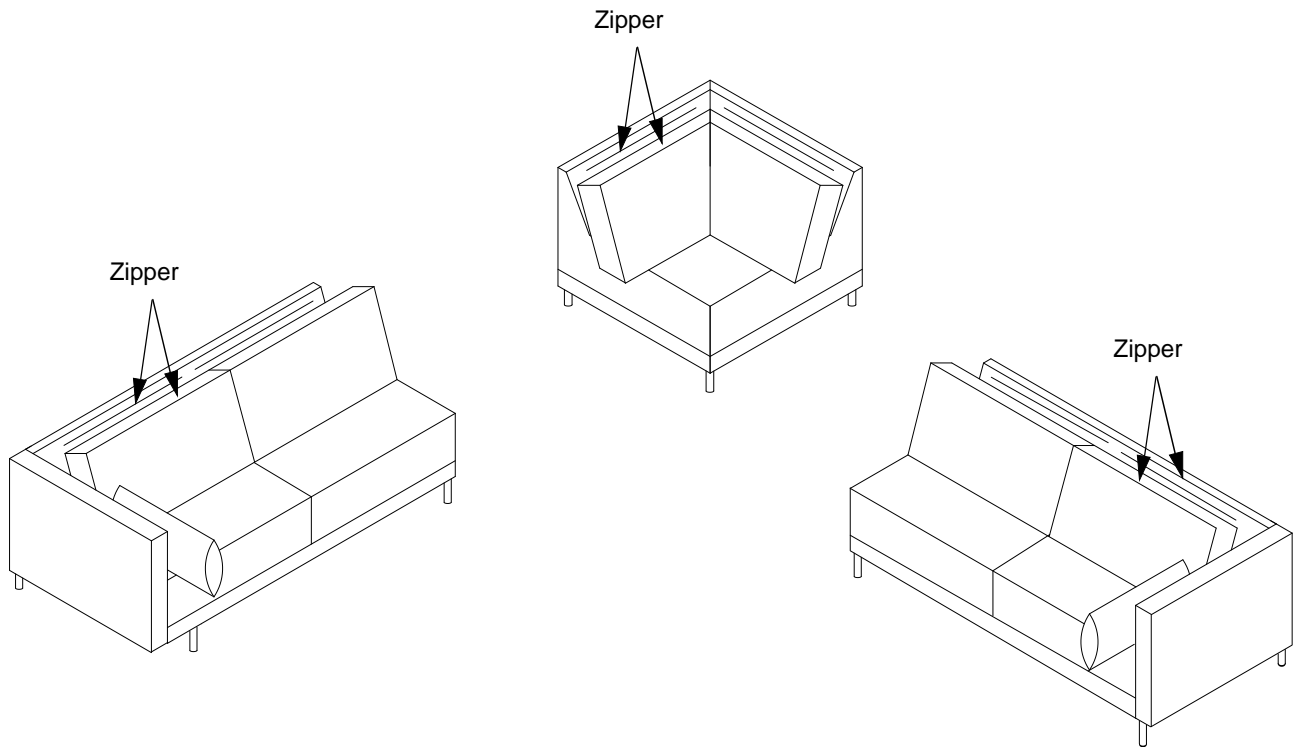

STEP3 Set up the sectional by connecting the brackets at seat sides

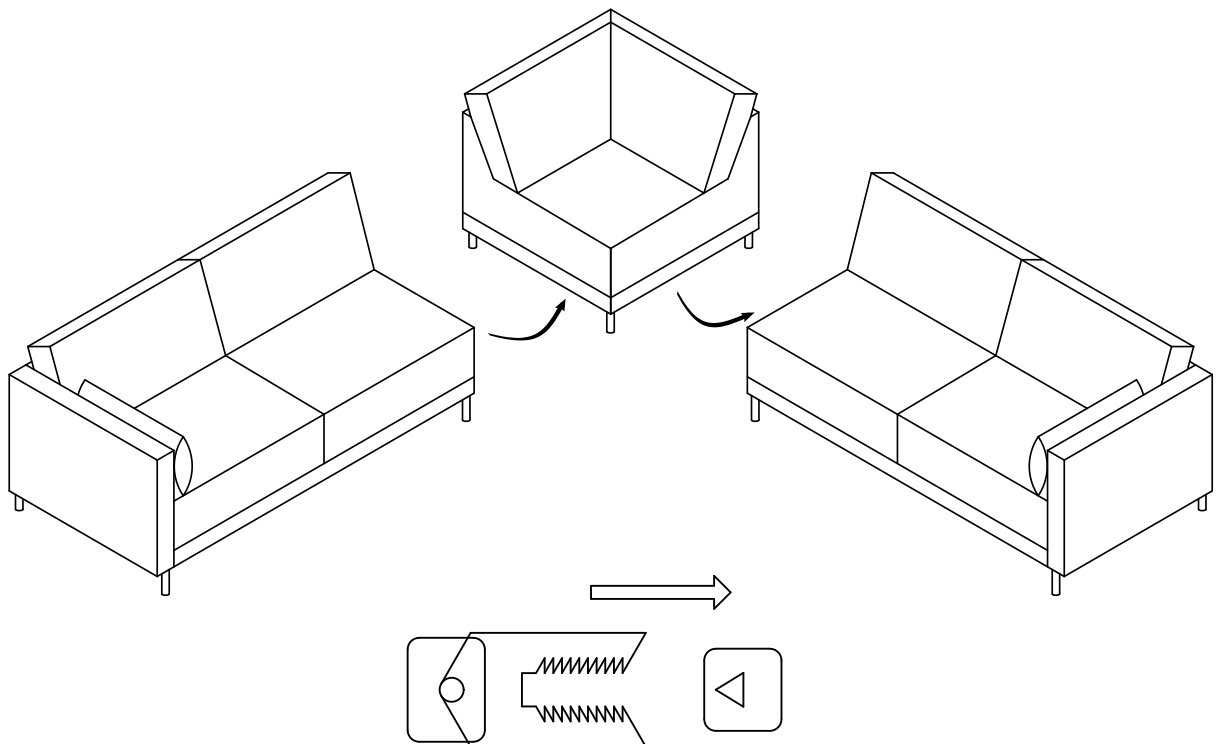

COMPLETE 3-PC SECTIONAL

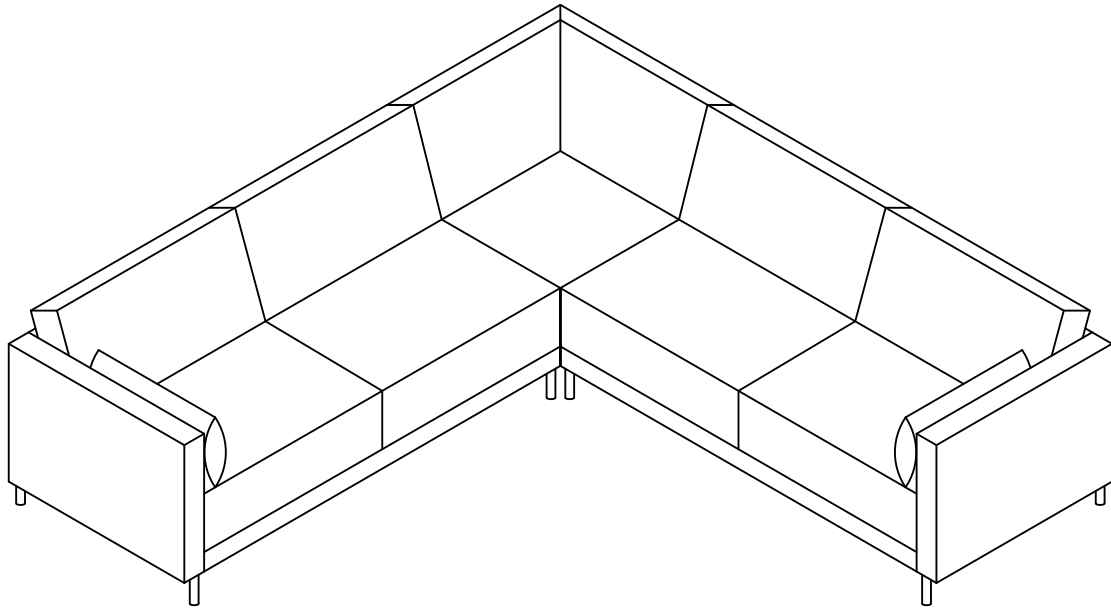

PRODUCT DETAILS

Seat Height 18"

Seat Depth 24"

Product Size

LAF Sofa 81"L x 37"W x 34.5"H

Corner Chair 36"L x 36"W x 34.5"H

LAF Sofa 81"L x 37"W x 34.5"H

Cube

LAF Loveseat 43.8 ft³

Corner Chair 20.05 ft³

LAF Loveseat 43.8 ft³

Net Weight

LAF Loveseat 106 lb

Corner Chair 71 lb

LAF Loveseat 106 lb

Gross Weight

LAF Loveseat 121 lb

Corner Chair 82 lb

LAF Loveseat 121 lb

**LEATHER CONTENT: TOP GRAIN AND SPLIT
FRAME MATERIAL: PLYWOOD & SOLID WOOD**

This fabric is not machine washable.
Allow +/- 3% residual shrinkage.

Do not use cleaning products containing brightening agents.
Do not clean with either eater or solvent based cleaner.
Using vacuuming or light brushing.

MADE IN CHINA