

Shark POWERDETECT™ **UV REVEAL™**

2-in-1 Vac + Mop with ThermaCharged™ NeverTouch™ Pro Base

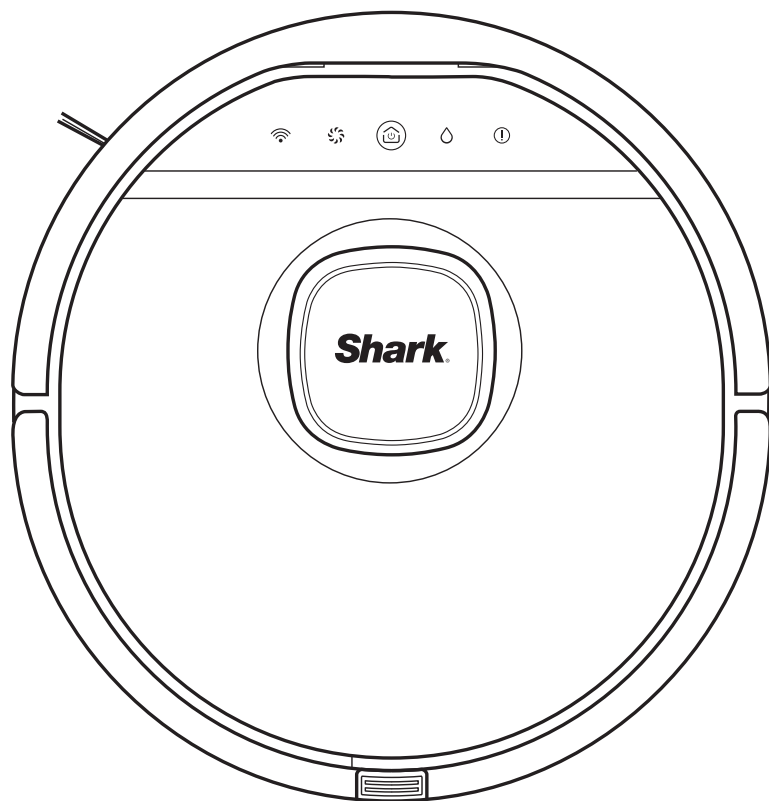

Robot Vacuum

RV3000WD Series

OWNER'S GUIDE



IMPORTANT SAFETY INSTRUCTIONS

PLEASE READ CAREFULLY BEFORE USE • FOR HOUSEHOLD USE ONLY

If the charging cable plug does not fit fully into the outlet, reverse the plug. If it still does not fit, contact a qualified electrician. DO NOT force into outlet or try to modify to fit.

⚠ WARNING

To reduce the risk of fire, electric shock, injury, or property damage:

LASER WARNING

This product has a class 1 laser. It is safe under reasonably foreseeable conditions (as defined in these instructions.) Always turn off the power before lifting the robotic vacuum cleaner or performing any maintenance on it. Do not look directly into laser.

GENERAL WARNINGS

When using an electrical appliance, basic precautions should always be followed, including the following:

1. The robotic vacuum cleaner system consists of a robotic vacuum and charging dock with power supply. These components contain electrical connections, electrical wiring, and moving parts that potentially present risk to the user.
2. Before each use, carefully inspect all parts for any damage. If a part is damaged, discontinue use.
3. Use only identical replacement parts.
4. This robotic vacuum cleaner contains no serviceable parts.
5. Use only as described in this Owner's Guide. **DO NOT** use the robotic vacuum cleaner for any purpose other than those described in this Owner's Guide.
6. This appliance can be used by children ages 8 years and older and persons with reduced physical, sensory, or mental capabilities or lack of experience and knowledge if they have been given supervision or instruction concerning use of the appliance in a safe way and understand the hazards involved. Children shall not play with the appliance. Cleaning and user maintenance shall not be made by children without supervision.
7. Children should be supervised to ensure that they do not play with the appliance.
8. This appliance contains batteries that are only replaceable by skilled persons.
13. **DO NOT** handle plug, charging dock, charging cable, or robotic vacuum cleaner with wet hands. Cleaning and user maintenance shall not be made by children without supervision.
14. **DO NOT** damage the charging cord:
 - a) **DO NOT** pull or carry charging dock by the cord or use the cord as a handle.
 - b) **DO NOT** unplug by pulling on cord. Grasp the plug, not the cord.
 - c) **DO NOT** close a door on the cord, pull the cord around sharp corners, or leave the cord near heated surfaces.
 - d) If the supply cord is damaged, it must be replaced by the manufacturer, its service agent or similarly qualified persons in order to avoid a hazard.
15. **DO NOT** put any objects into nozzle or accessory openings. **DO NOT** use with any opening blocked; keep free of dust, lint, hair, and anything that may reduce airflow.
16. Connect to a properly grounded outlet only. See Grounding Instructions.
17. **DO NOT** use robotic vacuum cleaner if airflow is restricted. If the air paths become blocked, turn the vacuum cleaner off and remove all obstructions before turning on the unit again.
18. Keep nozzle and all vacuum openings away from hair, face, fingers, uncovered feet, or loose clothing.

USE WARNINGS

9. This product has a Class 1 Laser. It is safe under reasonably foreseeable conditions (as defined in this Owner's Guide). Always turn off the power before lifting the robotic vacuum cleaner or performing any maintenance on it.
10. **DO NOT** look directly into laser.
11. **DO NOT** look directly into UV light. ⚠
12. **DO NOT** damage the UV lens. The UV lens cannot be replaced. If the lens is damaged the appliance should be scrapped.
19. **DO NOT** use if robotic vacuum cleaner is not working as it should, or has been dropped, damaged, left outdoors, or dropped into water.
20. **DO NOT** place vacuum cleaner on unstable surfaces.
21. **DO NOT** use to pick up:
 - a) Liquids.
 - b) Large objects.
 - c) Hard or sharp objects (glass, nails, screws, or coins).

- d) Large quantities of dust (drywall dust, fireplace ash, or embers.)
- e) **DO NOT** use as an attachment to power tools for dust collection.
- f) Smoking or burning objects (hot coals, cigarette butts, or matches).
- g) Flammable or combustible materials (lighter fluid, gasoline, or kerosene).
- h) Toxic materials (chlorine bleach, ammonia, or drain cleaner).
- i) Toxic materials (high concentrations of chlorine bleach liquid, high concentrations of ammonia, or drain cleaning solution).

22. **DO NOT** use in the following areas:

- a) Wet or damp surfaces.
- b) Outdoor areas near fireplaces with unobstructed entrances.
- c) Spaces that are enclosed and may contain explosive or toxic fumes or vapors (lighter fluid, gasoline, kerosene, paint, paint thinners, mothproofing substances, or flammable dust.)
- d) In an area with a space heater.
- e) Near fireplaces with unobstructed entrances.

23. Remove all spilled or leaked liquid from the base or floor as it could lead to risk of electrical shock and/or floor damage.

24. Turn off the robotic vacuum cleaner before any adjustment, cleaning, maintenance, or troubleshooting.

25. To prevent corrosion or damage, only use the Shark branded floor cleaner in the clean water tank. **DO NOT** add too much cleaning fluid to prevent the robot from working improperly due to slipping. To avoid water tank deformation, **DO NOT** add hot water in the tank, only room temperature water. If water marks remain on the water tank, wipe them clean before reinstallation.

26. Allow all filters to air-dry completely before reinstalling them to prevent liquid from being drawn into electric parts.

27. **DO NOT** modify or attempt to repair the robotic vacuum cleaner or the battery yourself, except as indicated in this Owner's Guide. **DO NOT** use the vacuum if it has been modified or damaged.

28. Keep fingers clear of wheels and suspension system at all times while robot is powered on. ⚠

29. **DO NOT** use any household cleaners (all purpose cleaners, glass cleaners, bleach) on any of the polished high gloss surfaces on the docking station or robot vacuum cleaner as they contain chemical that may

damage these surfaces. Instead use a cloth dampened with water to gently clean.

30. This appliance consists of a robotic vacuum cleaner and charging dock with power supply. These components contain electrical connections, electrical wiring, and moving parts that potentially present risk to the user.

31. **DO NOT** touch hot surfaces directly after cleaning missions. ⚠

32. With the exception of some filters and dust bin, **DO NOT** expose any parts of the robotic vacuum cleaner to water or other liquids.

33. Always turn off the robotic vacuum cleaner before inserting or removing the filter, dust bin, or fluid reservoir.

34. **DO NOT** use the robotic vacuum cleaner without the dust bin and filter in place.

35. If robotic vacuum cleaner is not starting from the dock, it must be placed in an unobstructed circle of 1.5 ft. (45 cm) away from edges and cliffs.

36. To minimize the risk of the robot traveling beyond an unsafe boundary (stair or cliff edges, fireplaces, water hazards), establish these areas as no-go zones using the mapping feature in the SharkClean mobile app. Upon setting the boundary, run the vacuum and visually confirm that the settings effectively prevent the robot from passing beyond the set boundary. Adjust settings as necessary. For nonapp users, use a boundary to block off an unsafe boundary.

BATTERY USE

37. The battery is the power source for the vacuum. Carefully read and follow all charging instructions.

38. To prevent unintentional starting, ensure the vacuum is powered off before picking it up or carrying it.

39. For Shark® NeverTouch™ Pro dock replacement, use XDRV3000XLB, XDRV3000XLW, XDRV3000XL3, XDRV3000XL4, XDRV3000XL5, XDRV3000XL6 or equivalent. For replacement batteries, use RVBAT85013 (40P) or RVBAT85014 (50E) battery packs.

40. Keep the battery away from all metal objects such as paper clips, coins, keys, nails, or screws. Shorting the battery terminals together increases the risk of fire or burns.

41. Under abusive conditions, liquids may be ejected from the battery. Avoid contact with this liquid, as it may cause irritation or burns. If contact occurs, flush with water. If liquid contacts eyes, seek medical help.

42. Robotic vacuum cleaner should not be

stored, charged, or used at temperatures below 50°F (10°C) or above 104°F (40°C). Ensure the battery and vacuum have reached room temperature before charging or use. Exposing the robotic vacuum cleaner or battery to temperatures outside of this range may damage the battery and increase the risk of fire.

43. **DO NOT** expose the robotic vacuum cleaner or battery to fire or temperatures above 265°F (130°C) as it may cause explosion. Battery usage conditions:

44. <10 °C (50 °F)	Do not store.
>40 °C (104 °F)	Do not store.
20 °C -40 °C	Normal operating temp.
<0 °C (32 °F)	Do not charge.

GROUNDING INSTRUCTIONS

This appliance must be grounded. If it should malfunction or breakdown, grounding provides a path of least resistance for electric current to reduce the risk of electric shock. This appliance is equipped with a cord having an equipment-grounding conductor and grounding plug. The plug must be inserted into an appropriate outlet that is properly installed and grounded in accordance with all local codes and ordinances.

⚠ WARNING

Improper connection of the equipment-grounding conductor can result in a risk of electric shock. Check with a qualified electrician or service person if you are in doubt as to whether the outlet is properly grounded. Do not modify the plug provided with the appliance - if it will not fit the outlet, have a proper outlet installed by a qualified electrician.

This appliance is for use on a nominal 120-V circuit and has a grounding attachment plug that looks like the plug illustrated in sketch A in the following Figure. Make sure that the appliance is connected to an outlet having the same configuration as the plug. No adaptor should be used with this appliance. If the appliance must be reconnected for use on a different type of electric circuit, the reconnection should be made by qualified service personnel.

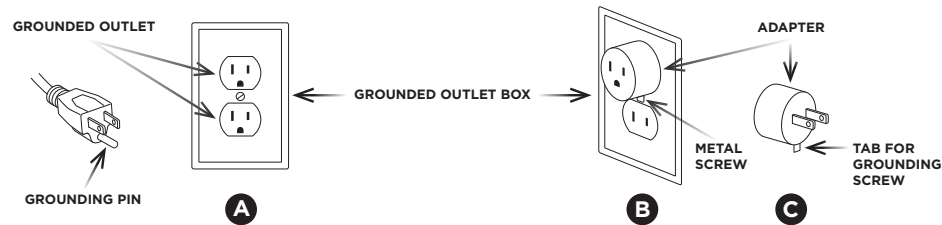

MOP PAD SANITIZATION INSTRUCTIONS

To achieve the sanitization benefit on the robot's mopping pad:

1. Fill the clean water tank on the base with distilled water up to the water O maximum fill line.
2. After each wet cleaning mission, allow the base to completely wash and dry the mopping pad without interruption.

SAVE THESE INSTRUCTIONS

For the latest warnings and cautions, go to support.sharkninja.com

WHAT'S INCLUDED

1. Robot Vacuum & Mop

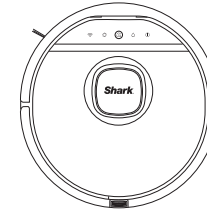

2. NeverTouch™ Pro Base

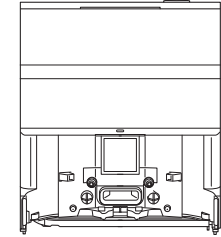

3. Side Brush (quantity varies)



4. Ramp

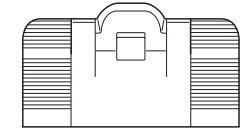

5. Odor Cartridge Assembly (quantity varies)

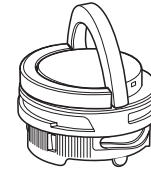

Note: Not included in all models

6. Shark® Multi-Surface Cleaner 12 oz. (355 ml) Bottle

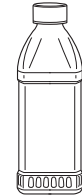

7. Robot Pre-Motor Filter (quantity varies)

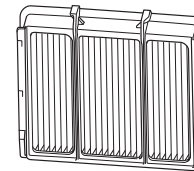

At least one filter is included in all models and comes pre-installed.

8. Base Post-Motor Filter (quantity varies)

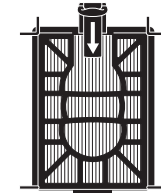

At least one filter is included in all models and comes pre-installed.

9. Base Pre-Motor Filters (quantity varies)

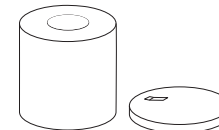

At least one filter is included in all models and comes pre-installed.

1 Set up Base

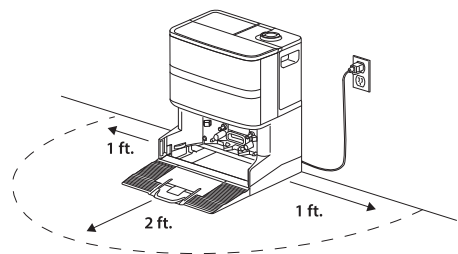

1. Remove all plastic wrap and foam.
2. Place the base on a flat, level **hard-floor surface** with at least **two feet of clearance in front and one foot on both sides, away from any objects, furniture, or a carpeted surface.**
3. Place the base close to your router for a strong Wi-Fi signal and ensure the base is not placed in an area with direct sunlight.
4. Select a permanent location for the base because every time you relocate it, your robot will have to re-map your space.
5. Plug in the base. The base indicator LED will turn white when the base is powered on.

2 Install Ramp on Base

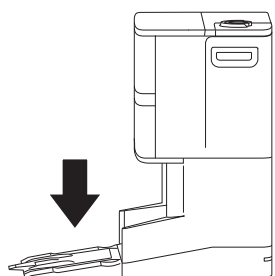

1. Align the flat side of the ramp with the bottom of the base.
2. **Lift the ramp slightly above the base, align, and press down until the ramp clicks into place.**
3. Leave at least 2 feet of hard floor space in front of the base, starting from the end of the ramp. **Do not place the base within 2 feet of carpet.**

3 Fill the Clean Water Tank

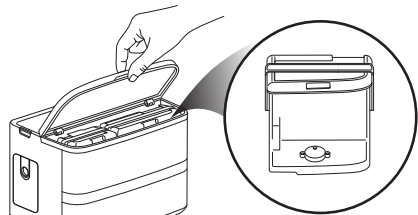

1. Lift the main lid on the front of the base. Remove the clean water tank with the blue handle.
2. **Add room-temperature water up to the H_2O fill line and no more than 12 oz. of Shark Multi-Surface Cleaner to the SC fill line.**

Note: ONLY use the provided Shark-branded floor cleaner.

4 Insert Odor Cartridge Assembly *Note: Not included in all models.*

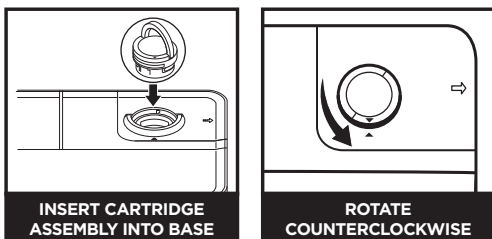

Note: Make sure the odor cartridge assembly is installed in the base before using the robot.

1. The odor cartridge can be found inside the robot box in a silver package. Open the package and remove the odor cartridge assembly.
2. Flip up the handle on the odor dial. Align the arrows and insert the assembly into the slot on the top right side of the base.
3. To lock and engage the cartridge, rotate it **counterclockwise** until it clicks at least once.
4. Continue to rotate the dial toward the high position to increase the intensity.

1 Install One Side Brush

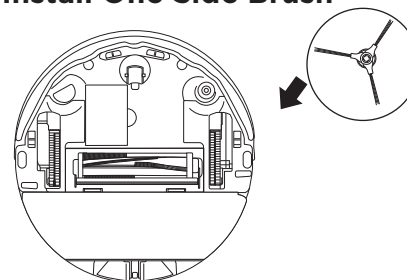

1. Remove all plastic wrap and take one side brush from the side brush box.
2. Align the hole in the brush over the peg on the bottom of the robot, then press down on the brush until it clicks into place.

Note: Additional side brushes may be included as replacement parts, but only one should be installed on the robot.

2 Slide Robot Onto Base to Charge

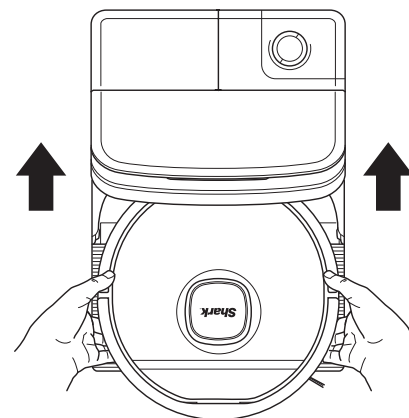

1. **Align the robot with Shark logo upside down, then slide it up the ramp, onto the base.**
2. The base indicator light will turn **green** when the robot is charging.

3 Download the SharkNinja® app



1. When prompted by the app, press the Wi-Fi Wi-Fi button on your robot to enter Pairing mode. Once in pairing mode, your robot will say "I am ready to connect to Wi-Fi".

Unlock full functionality with the app, including:

- ✓ Scheduling
- ✓ Personalized Routines
- ✓ Remote Control
- ✓ Cleaning Reports
- ✓ No-Go Zones



NOTE: If the Wi-Fi button is not responding, hold Wi-Fi + Home for 3 seconds to reset Wi-Fi.

GETTING TO KNOW YOUR SHARK® ROBOT

TOP

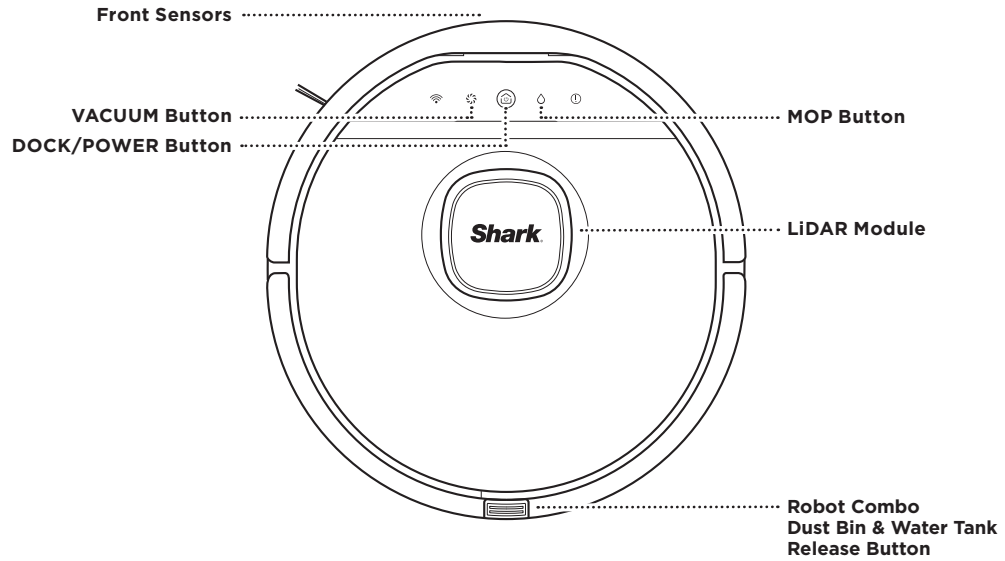

BOTTOM

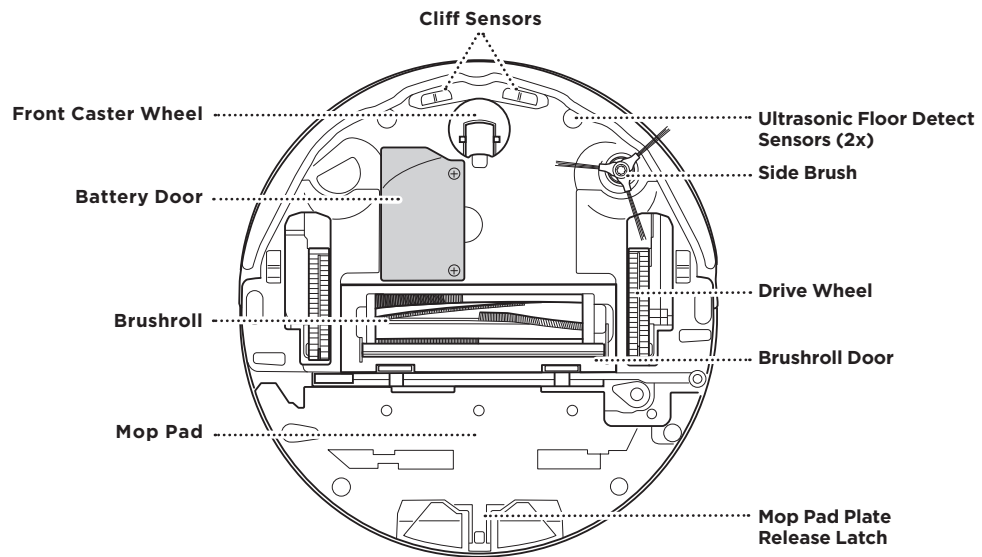

GETTING TO KNOW YOUR NEVERTOUCH™ PRO BASE

FRONT

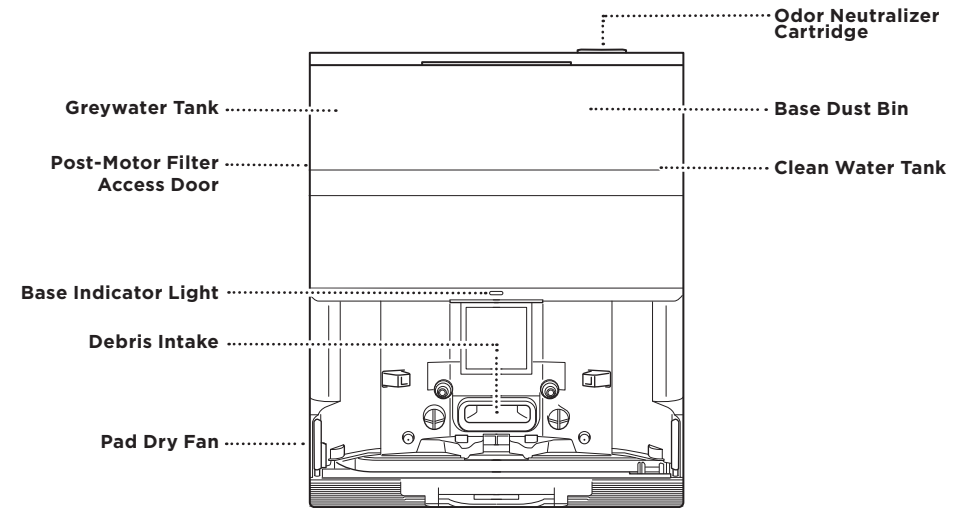

BACK

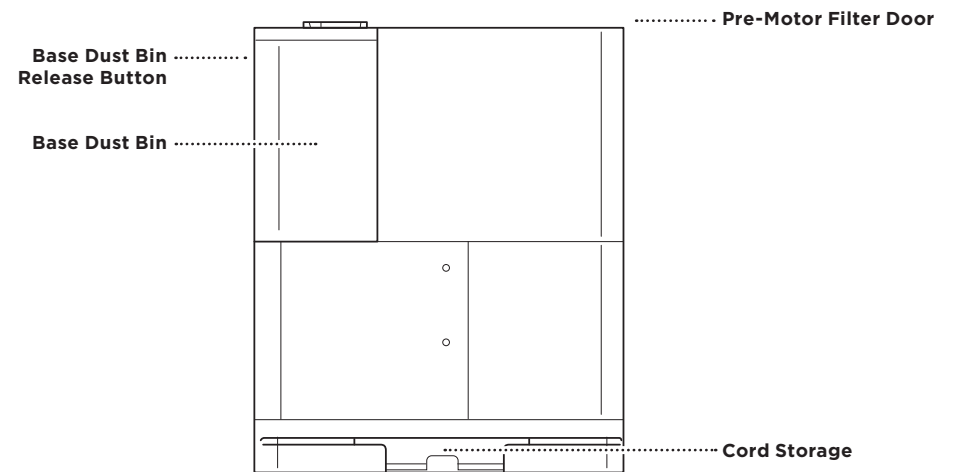

GETTING TO KNOW YOUR NEVERTOUCH™ PRO BASE

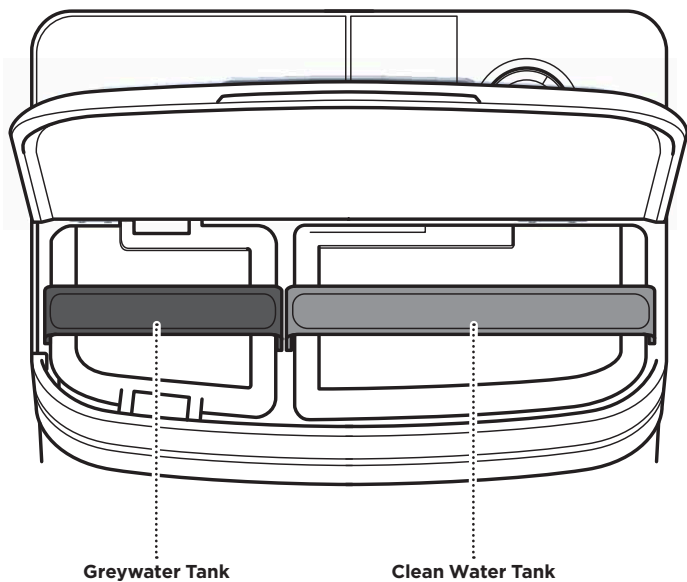

Greywater Tank

Clean Water Tank

Charging Contacts

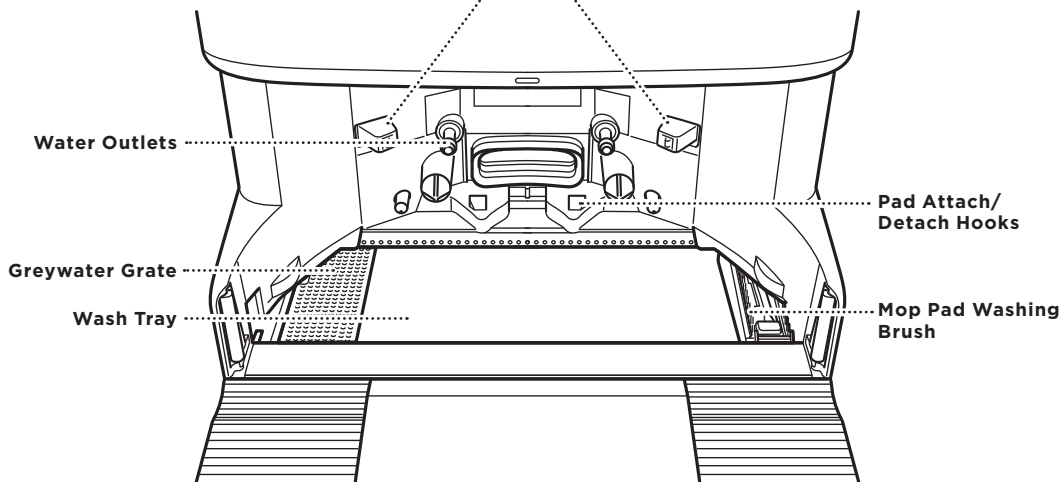

Water Outlets

Greywater Grate

Wash Tray

Pad Attach/
Detach Hooks

Mop Pad Washing
Brush

PREPARE YOUR HOME

Your robot uses an array of sensors to navigate around walls, furniture legs, and other obstacles while it cleans. For best results, prepare your home as indicated below.



OBSTRUCTIONS

Your PowerDetect™ robot detects obstacles and navigates around them. To ensure a complete map of your home, before the robot's first Explore Run, remove objects such as socks, shoes, and toys and open all interior doors.

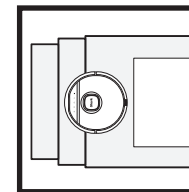

STAIRS

Your robot's cliff sensors will prevent it from falling off ledges. For the cliff sensors to work properly in any mode, all runners, rugs, or carpets must be at least 8 inches from any stairs, or must extend over the edge of the stairs.

MAPPING YOUR HOME

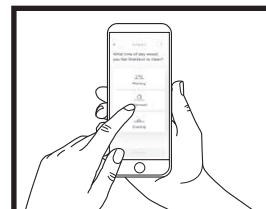

After setup is complete, your robot will conduct an **Explore Run** to create an initial map of your home. In your SharkNinja® app select:

Quick Explore:

- The robot will quickly enter and look around each room to identify walls, furniture, and other obstacles. This should take approximately 10 minutes.
- Following Quick Explore, there is an option to have the robot complete a Carpet Detection Run in select rooms, which will allow it to accurately map the carpeted area and avoid them during wet cleaning missions.

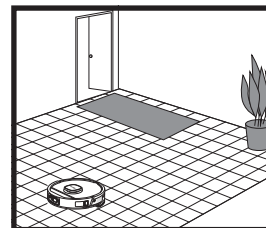

While we recommend connecting to the app, you can also manually send your robot to explore and clean:

- Tap Vacuum  on your robot. On its first run, your robot will automatically vacuum while mapping, identifying walls, furniture, carpets, and other obstacles.
- This first run can take up to a few hours depending on the size of your home.

NOTE: It is necessary to send the robot to explore your whole home before it can be sent on a mopping mission.

3D SENSOR & AI LASER NAVIGATION

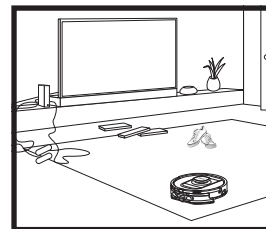

Object Detection: The robot's object detection technology helps it navigate around obstacles, as well as some common household objects left on the ground like cords, cables, shoes, toys, and clothes.

Carpet Mapping: Your robot will detect carpeted areas during its first vacuum mission. If carpets are moved, you may need to have the robot re-explore your home.

TIP: Be sure to charge the robot completely before its first clean so that it can explore, map, and clean as much of your home as possible. It may take up to 4 hours* to fully charge your robot.

*Battery charge time may vary.

LIVING WITH YOUR ROBOT

Questions? For how-to videos, FAQs, troubleshooting, and tips & tricks, visit: support.sharkninja.com or call **+1-888-668-9600** for robot support.

AVOID MOVING THE ROBOT OR BASE

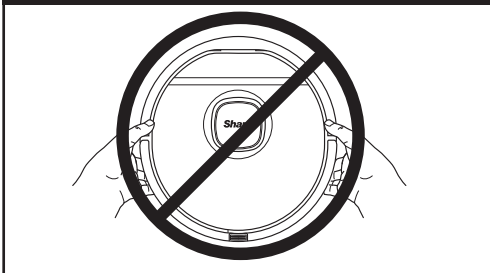

While your robot is cleaning, **DO NOT** pick it up and move it, or move the NeverTouch™ Pro Base—this will impact the robot's ability to map your home. If the base is moved, you will need to remap your home.

DOORWAYS & THRESHOLDS

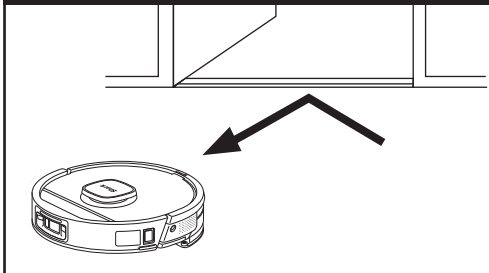

With NeverStuck™ Technology, your robot can easily climb over most thresholds, but if one is higher than 1 inch, set up a no-go zone in the app to block it off.

CHARGING

IMPORTANT: Be sure to charge the robot completely before its first clean so that it can explore, map, and clean as much of your home as possible. It may take up to 4 hours* to fully charge your robot.

POWER/ON OFF

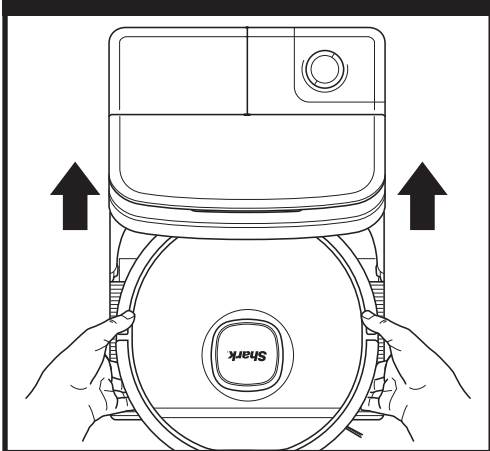

To power on the robot, place it on the base to charge. Align the robot with the Shark logo upside down, then slide it up the ramp onto the base. To power off the robot, remove it from the base and hold the Power/Dock button for 3 seconds.

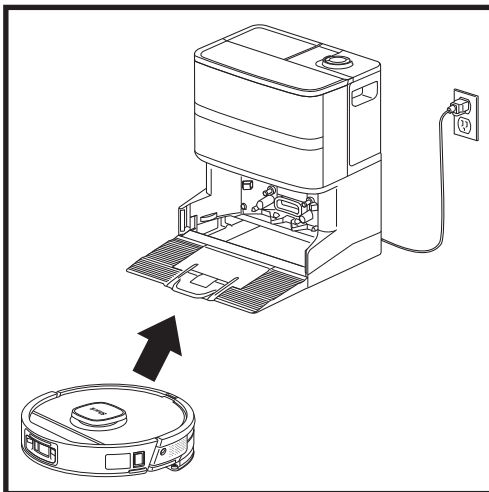

When the cleaning mission is complete, or if the battery is running low, the robot will search for the base and automatically dock itself. If the robot doesn't return to the base, it may have encountered trouble along the way. Manually slide the robot back onto the base to charge and get ready for the next mission.

NOTE: When manually placing the robot on the base, make sure the charging contacts on the back end of the robot are touching the ones on the base.

NOTE: When picking up the robot, be careful not to place fingers between the bumper and the back of the robot.

*Battery charge time may vary.

ROBOT USER INTERFACE

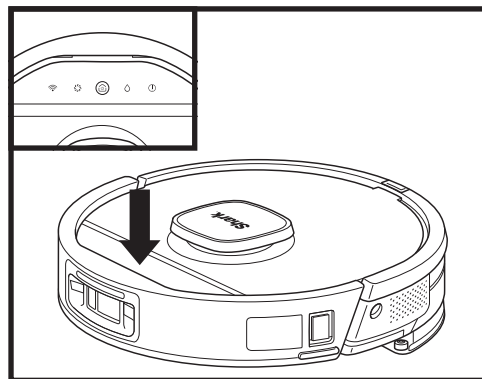

ROBOT USER INTERFACE



WI-FI BUTTON

- When illuminated, tap to put the robot in Pairing mode.
- The icon will breathe **BLUE** when in pairing mode and turn **OFF** once connected.



VACUUM BUTTON

- Tap to start vacuuming. The icon will illuminate **PURPLE** while the robot is vacuuming. Tap again to pause the cleaning session.



POWER/DOCK BUTTON

- Tap to send the robot back to the base. Tap again to pause docking.
- Hold for 3 seconds to power the robot on or off.



MOP BUTTON

- Tap to start vacuuming and mopping bare floors. The icon will illuminate **BLUE** while the robot is mopping. Tap again to pause the mopping session.



ERROR BUTTON

- When illuminated, tap the button to repeat the error message.
- **RED** errors require immediate attention, and **ORANGE** errors require maintenance.

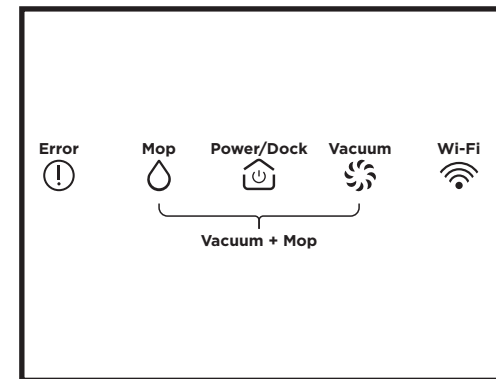

ADDITIONAL TIPS & TRICKS

WI-FI RESET

- If the Wi-Fi button is **NOT** illuminated but your robot is still not connected to the app, you will need to reset the Wi-Fi.
- Hold + + for 3 seconds to reset Wi-Fi.

VACUUM + MOP

- Hold + for 3 seconds to begin a whole-home clean. The robot will first vacuum carpets, then vacuum and mop hard floors.

SPOT CLEANING

- To clean a 5-foot by 5-foot area of your home, place the robot on the spot you wish to clean and hold for 3 seconds to vacuum or for 3 seconds to mop.

NOTE: During a mop mission the robot will also vacuum, but only on bare floors. To vacuum carpets, select Vacuum + Mop mode.

DETECT INDICATORS

Your Shark® PowerDetect™ robot can detect floor types, edges, and debris. There are some helpful indicators on the robot to notify you when a dirty area has been identified for more intensive cleaning.



DIRT DETECT senses dense debris areas and automatically boosts suction and makes extra passes until no more dirt is detected.

- When a mess is detected, the lights underneath the robot will turn **PURPLE** to indicate that Dirt Detect has been triggered.



UV STAIN DETECT™ locates and attacks stubborn stuck-on stains with increased saturation and pad agitation through a specialized wiggle behavior.

- When stains have been detected, the lights underneath the robot will turn **BLUE** to indicate that UV Stain Detect™ is enabled.
- After a mopping mission, your robot will provide a cleaning report showing where stains were detected and can re-clean those areas if desired, after washing its mopping pad at the base. UV Stain Detect™ can also be controlled manually through the app or toggled off.
- UV Stain Detect™ works for whole-home cleaning or individual rooms, and there is also a Spot Clean function for targeted stain removal.



ERROR DETECT is triggered when your robot senses there is a problem.

- When an error is detected, the lights underneath the robot will turn **RED**, indicating immediate attention is required.
- When a warning is detected, the lights underneath the robot will turn **ORANGE**, indicating maintenance is required. Please tap the Error button on the robot's user interface to have the robot repeat the error message.

Please visit support.sharkninja.com or call 1-888-668-9600 for answers to all your app questions.

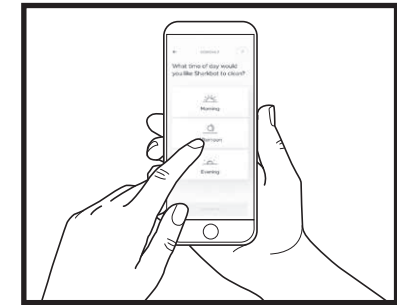
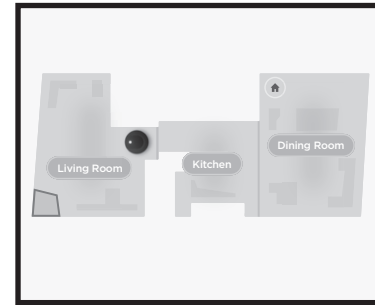

Get the most out of your Shark® robot vacuum with these app features:

QUICK EXPLORE

- Your robot will spend a few minutes exploring and creating an initial map of your home.

VACUUM + MOP

- Full-home cleaning. Vacuuming of carpeted areas, followed by vacuuming and mopping of bare floors.

NO-GO ZONES

- Set up no-go zones in the app to keep your robot out of the areas you would like it to avoid.

SCHEDULING

- Set up whole-home or room-specific cleanings for any time, any day.

CONTROL FROM ANYWHERE

- Wherever you are, you're in control of your robot.

CUSTOMIZABLE SETTINGS

- Easily adjust suction power, mop pad saturation level, and notification volume, and much more.

CLEANING REPORTS

- Each time your robot cleans, your app will generate a cleaning report.

SETTING UP VOICE CONTROL

Visit support.sharkninja.com for setup instructions, which include how to enable Shark Skill for Amazon Alexa and using your robot with Google Assistant.

Google Assistant:

- Hey Google, start vacuuming.
- Hey Google, tell (robot name) to vacuum.
- Hey Google, pause vacuuming.
- Hey Google, tell (robot name) to go home.

Amazon Alexa:

- Alexa, ask Shark to start vacuuming/cleaning the (room name).
- Alexa, start/stop the robot.
- Alexa, send the robot to the base.

Please visit support.sharkninja.com or call 1-888-668-9600 for answers to all your app questions.

How do I use my robot with Amazon Alexa?

Open the Amazon Alexa app, go to the menu and select Skills. Or go to the Alexa Skills store on the Amazon website. Search for "Shark Skill". Select the Shark Skill to open the detail page, then select the Enable Skill option. Once enabled, you can ask Alexa to control your robot (i.e., "Alexa, tell Shark to start cleaning").

How do I set up my robot with the Google Assistant on an Apple device?

1. Download, open, and sign into the Google Assistant app. **2.** Select the "Explore" icon. Search for "Shark" and select "Try it." **3.** To allow Google to link to your SharkNinja® account, sign into your SharkNinja account. This is the same account you used when setting up your Shark robot in the SharkNinja app. Select "Authorize" to link your SharkNinja account to the Google Assistant. The Google Assistant now works with your Shark robot. To send your robot into action, use the voice command, "Google, tell Shark to start cleaning."





How do I set up my robot with the Google Assistant on Android?

1. Download, open, and sign into the Google Assistant app. **2.** Select the "Explore" icon. Search for "Shark" and select "Link." **3.** Sign into your SharkNinja account. This is the same account you used when setting up your Shark robot in the SharkNinja app. Congratulations! The Google Assistant now works with your Shark robot. To send your robot into action, use the voice command, "Google, tell Shark to start cleaning."

What should I do if my Wi-Fi randomly disconnects?

Turn OFF the robot by removing it from the base and holding the Power/Dock  button for 3 seconds. Wait 30 seconds, then turn the robot back on by sliding it onto the base to charge. Turn off your phone. Wait 30 seconds, then turn your phone back on. Open Wi-Fi settings on your phone, find the Shark network, and select Forget Network. Reopen the SharkNinja app and retry the connection process. It is normal for your robot to temporarily lose connectivity when it goes under furniture or moves far from your router. Your Shark® robot will automatically reconnect to Wi-Fi. If the robot does not reconnect, power it off, wait 30 seconds, power it back on, and place it back on the base.

What should I do if my robot is not connected to Wi-Fi, but I do not see the Wi-Fi icon?

Reset your robot's Wi-Fi. Hold  +  +  on the robot for 3 seconds to reset Wi-Fi. The Wi-Fi  icon will illuminate **BLUE** to indicate the robot is in Pairing mode and the robot will say "I am ready to connect to Wi-Fi".

What should I do if I verified a wireless network password that is incorrect?

Close the app, then reopen it. Make sure to enter the correct Wi-Fi network password this time. In your phone's network settings, choose your home 2.4 GHz network, and select Forget. Reconnect to your home network. Make sure to use the correct password. If you were able to connect to your home network, proceed to the app setup process. We recommend that you use the eye icon when entering your password to make sure it is correct. Turn off your router and wait 30 seconds. Turn your router back on. Check to make sure your 2.4 GHz network is visible in your phone settings. Turn off the robot, then wait 10 seconds. Turn the robot back on and wait for the voice prompt. Hard-close the app and restart the connection process on the robot. If you cannot locate your Wi-Fi password, please contact your Internet service provider.

What should I do if my username or password is invalid?

We recommend you select the eye icon next to the password entry to verify you are entering your password correctly. Select the "Forgot Password" option on the sign-in page. The automated system will email you a link to reset your password. If you do not see an email, search your inbox and spam folder for emails from mysharkninja@sharkninja.com. You can use the "Resend code" option to send the email again.

What should I do if there is an issue resetting password (did not receive the email or token was invalid)?

Select the "Forgot Password" option on the sign-in page. The automated system will email you a link to reset your password. If you do not see an email, search your inbox and spam folder for emails from mysharkninja@sharkninja.com. You can use the "Resend code" option to send the email again.

What should I do if my robot won't connect to Wi-Fi or loses Wi-Fi connectivity?

If you are an iOS user, you need to enable local network access on your phone for the SharkNinja app. Please take the following steps to enable.



- Go to your phone settings → Select Privacy → Select Local Network → Toggle SharkNinja on, then try connecting again.
- Ensure your phone is connected to your home Wi-Fi network before trying to connect your robot.
- Typical home Wi-Fi networks support both 2.4 GHz and 5 GHz. Ensure you are connected to a 2.4 GHz network when you enter your username and password.
- Ensure your robot is turned on and you hear an audio prompt. Do not use a VPN or a proxy server. Ensure Wi-Fi isolation is turned off on the router.

Note: Shark® robot vacuums cannot connect to 5 GHz band.

WI-FI TROUBLESHOOTING

- Typical home Wi-Fi networks support both 2.4 GHz and 5 GHz.
- Do not use a VPN or a proxy server. Hotspot available to connect only at 2.4 GHz.
- Make sure Wi-Fi isolation is turned off on the router.

Reset your Wi-Fi

- Hold the  +  +  on the robot for 3 seconds to reset Wi-Fi.
- If you cannot connect, call **1-888-668-9600**.

STILL CAN'T CONNECT?

Restart your phone

- Turn off phone, wait 30 seconds, then turn it back on and connect to Wi-Fi.

Reboot your robot

- Turn OFF the robot by removing it from the base and holding the Power/Dock  button for 3 seconds. Wait 30 seconds, then slide the robot back on the base to power it ON.

Reboot your router

- Unplug the router power cable for 30 seconds, then plug it back in. Allow several minutes for your router to reboot completely.

NOTE: The following network interfaces and services of the device are enabled by default:

- Bluetooth interface: used for equipment configurations through the app.
- Wi-Fi interface: used for equipment network connection.
- NTP service: used to obtain the time.

BASE MAINTENANCE OVERVIEW

CAUTION: Before performing any maintenance, unplug the base from the electrical outlet.

Component	Frequency	Replacement Part(s)
Base Dust Bin	Empty every 60 days, or as needed.	XDRV29XLD0B XDRV29XLD0W
Base Pre-Motor Filters	Clean every 30 days, or as needed.	XMFRV2500S
Base Post-Motor Filter (HEPA)	Clean every 6 months, or as needed.	XPSFRV2500
Base Ramp	Clean every 3 months, or as needed.	XDRV2900RPB XDRV2900RPG2
Base Wash Tray	Clean every 30 days, or as needed.	N/A
Greywater Grate	Clean every 30 days, or as needed.	XMFRV2900WD
Odor Neutralizer Technology <small>NOTE: Odor Neutralizer Technology is not included with all models.</small>	Replace the odor cartridge every 6 months, or as needed.	268ZQ3000
Clean Water Tank	Clean every 30 days, or before every refill.	XDRV29XLCW
Greywater Tank	Clean every 30 days, or as needed.	XDRV29XLDW

MOP PAD SANITIZATION INSTRUCTIONS

To achieve the sanitization benefit on the robot's mopping pad:

1. Fill the clean water tank on the base with distilled water up to the water  maximum fill line.
2. After each wet cleaning mission, allow the base to completely wash and dry the mopping pad without interruption.

To purchase parts and accessories, visit sharkninja.com/accessories.

ROBOT MAINTENANCE OVERVIEW

CAUTION: Before performing any maintenance, power off your robot by holding the Power/Dock  button on the robot for 3 seconds, then remove the water tank.

Component	Frequency	Replacement Part(s)
Brushroll	Clean every 30 days, or as needed.	278KKU2800 278KKU2801
Filter	Clean every 30 days, or as needed.	XPRFRV2500
Dust Cup	Clean every 30 days, or as needed.	XDC2900WDB XDC2900WDW
Mop Pad <small>NOTE: After every wet cleaning mission, the base will automatically wash and dry the robot mop pad. Additional cleaning in a washing machine may be needed occasionally.</small>	Replace every 2 years, or as needed.	PADRV29WDA PADRV290WDA
Sensors and Charging Contacts	Clean every 30 days, or as needed.	N/A
Side Brush	Replace as needed.	820KKU2800WD

Sensor Name	Functional Description
Cliff Sensor	Cliff sensors use infrared ranging to prevent your robot from falling off stairs and ledges. If the cliff sensors detect stairs or ledges, the robot will stop moving forward.
LiDAR Sensor	The LiDAR sensor uses laser ranging to help the robot create maps of your home. Detective distance is 8 m.
RGB 3D Sensor	With one RGB camera, one line-laser and one IR camera, the 3D sensor scans objects to identify an image through algorithms. FOV: H = 94.7°, V=75.1°, D=115.6°.
Left Wall Follow Sensor	The left wall follow sensor detects the distance between objects and the left side of the robot through TOF ranging. The detective distance is 30 mm.
Right Wall Follow Sensor	The right wall follow sensor detects the distance between the objects and the right side of the robot through the line laser. Detective distance is 100 mm.

To purchase parts and accessories, visit sharkninja.com/accessories.

BASE MAINTENANCE

CAUTION: Before performing any maintenance, unplug the base from the electrical outlet.

MAINTAINING THE BASE DUST BIN

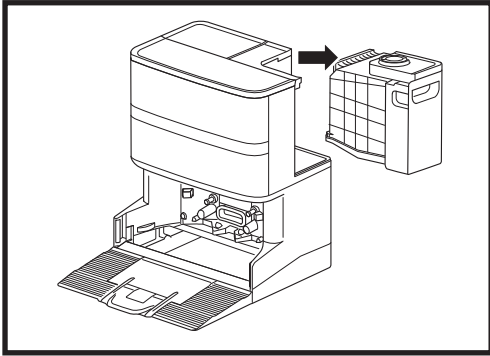

1. Empty the base dust bin every 60 days.
2. To detach the bin, press the **Dust Bin Release** button on the back right side of the base, then slide out the bin.

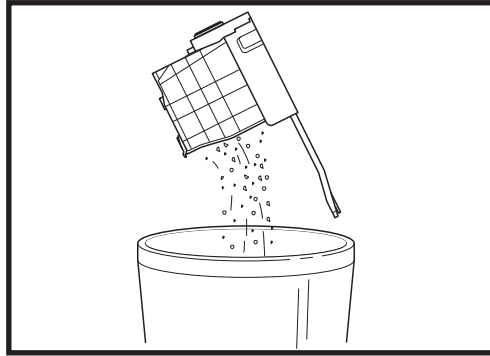

3. To empty the bin, hold it over the trash, then press the orange release button on the side of the bin. Lightly tap the dust bin against the inside of the trash receptacle to knock off any remaining debris. Use a dry cloth to wipe off the gray mesh filters on the inside of the dust bin. Reinstall the bin by sliding it into the slot in the base until it clicks into place.

CLEANING & REPLACING THE BASE FILTERS

Regularly clean the filters to keep your vacuum's suction power optimal. Replace filters every 6-12 months or as needed.

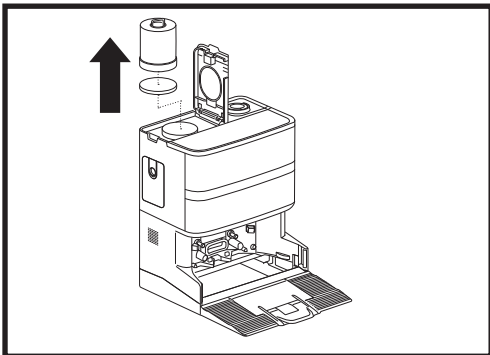

CLEAN PRE-MOTOR FILTERS ONCE A MONTH

To open the filter housing lid, hold the top left edge of the base, and pull up on the lid. With the lid open, remove the foam filter by the top handle, then lift out the felt filter underneath. Tap the filters clean over the trash, then **rinse with cold water ONLY**, as soap may damage them. Allow filters to air-dry completely for at least 48 hours before reinstalling to prevent liquid from being drawn into electrical parts. The filters must be installed correctly for the base to work properly. Reinsert the felt filter first, then the foam filter.

IMPORTANT: DO NOT use soap when cleaning the filters.

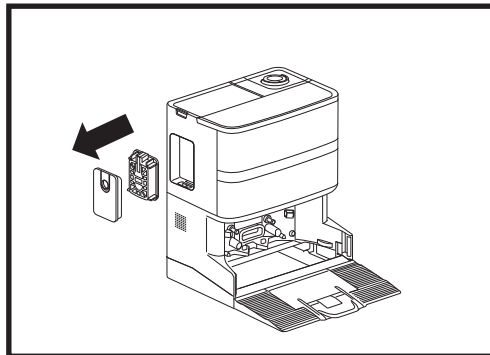

CLEAN POST-MOTOR FILTER EVERY SIX MONTHS

Slide down the tab at the top of the filter door to remove the door and access the base post-motor filter. Pull down the teal tab to remove the filter.

Tap the filter clean over the trash. **DO NOT use water or soap to clean this filter, as this will cause damage.** More frequent cleaning may be required with heavy use.

To reinstall, insert the bottom half of the filter first, then push in until the filter clicks into place. With the filter installed, reinsert the filter door into the base.

BASE MAINTENANCE

CAUTION: Before performing any maintenance, unplug the base from the electrical outlet.

CLEANING THE WASH TRAY

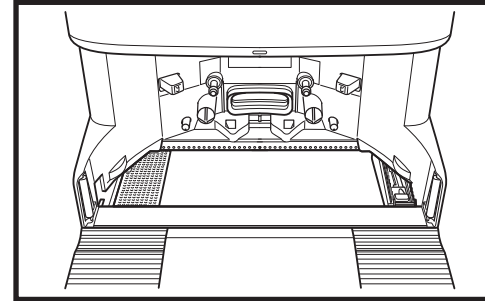

1. With the robot removed, you can access the base wash tray.
2. To clean the wash tray, wipe it down with a damp microfiber cloth.
3. Locate the mop pad washing brush on the right side of the wash tray. Remove any hair or debris from around the bristles and use a damp cloth to wipe away any stuck-on debris.

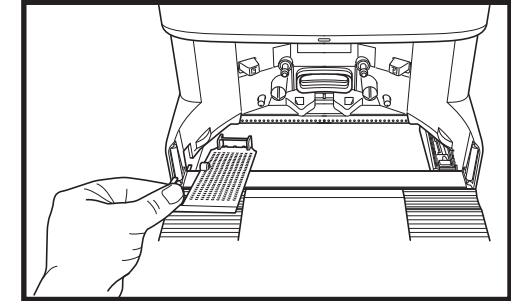

4. Carefully remove the greywater grate on the left-hand side and wash with water to clear any debris. Reinstall the grate, ensuring it is seated properly in its slot. If the grate has wedged out of place, remove it and reinstall so that it sits flush in the wash tray.
5. Allow the wash tray to completely dry for at least 48 hours before reinstalling the robot.

REPLACING THE ODOR CARTRIDGE

Replace the Odor Neutralizer Technology cartridge every 6 months, or as needed.

1. Flip up the handle and rotate the dial counterclockwise until the two arrows are aligned. Pull the handle to remove the dial from the base.

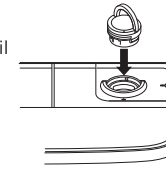

2. Rotate the cartridge counterclockwise in the dial housing and pull out the cartridge to remove it.

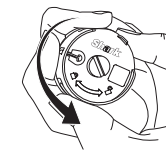

3. Remove the new odor cartridge from the sealed packaging. To maintain the life of the cartridge, keep it in the sealed packaging until you are ready to install it.



4. Align the yellow arrow on the side of the cartridge with the yellow arrow on the side of the dial cover, then insert the cartridge into the dial. Rotate the cartridge clockwise to lock it in place.

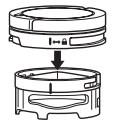

5. Align the arrow on the dial cover with the arrow on the base, then reinsert the dial into the base. Rotate the dial counterclockwise until it clicks into an intensity setting to engage. Rotate further to change the intensity setting.

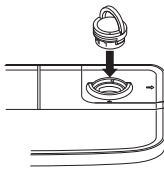

6. Dispose of the old cartridge by dropping it into the trash.



NOTE: Odor Neutralizer Technology is not included in all models.

BASE MAINTENANCE

CAUTION: Before performing any maintenance, unplug the base from the electrical outlet.

MAINTAINING THE BASE WATER TANKS

CLEAN WATER TANK

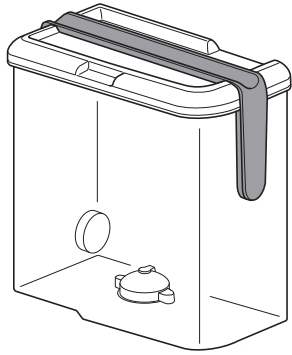

1. Clean the base clean water tank before every refill, or once every 30 days.
2. Wash the clean water tank with warm water and soap. Rinse thoroughly.
3. Add room-temperature water up to the \hat{O} fill line and no more than 12 oz. of Shark Multi-Surface Cleaner to the S fill line.

GREY WATER TANK

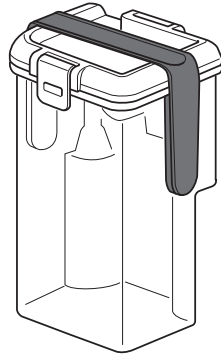

1. The greywater tank collects and stores dirty water after every pad wash.
2. This tank should be emptied and cleaned every 30 days, or as needed.
3. To empty the tank into a toilet, open the lid and pour out the dirty water.
4. Add a small amount of soap to the tank and rinse it thoroughly in the sink with warm water.
5. Allow the tank to air-dry for at least 48 hours before reinstalling.

NOTE: ONLY use the provided Shark-branded floor cleaner.

DO NOT reinstall any water tanks filled with warm water. Always use room-temperature water in the tanks.

DO NOT move the base while the water tank is full.

CLEANING THE BASE RAMP

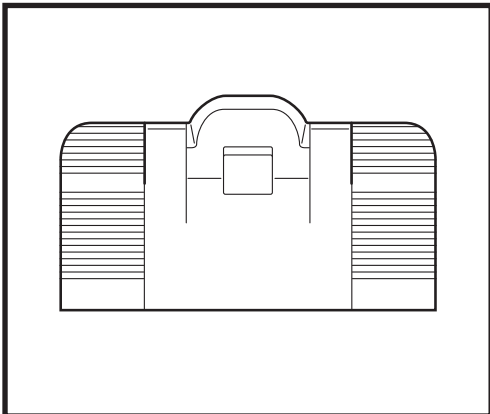

Clean the base ramp every three months or as needed.

1. Carefully lift the ramp up and away from the base.
2. Use a damp cloth to wipe down the ramp.
3. To reinstall, lift the ramp slightly above the base, align, and press down until the ramp clicks into place.

BASE MAINTENANCE

CAUTION: Before performing any maintenance, unplug the base from the electrical outlet.

CLEANING THE BASE-TO-ROBOT CONNECTIONS

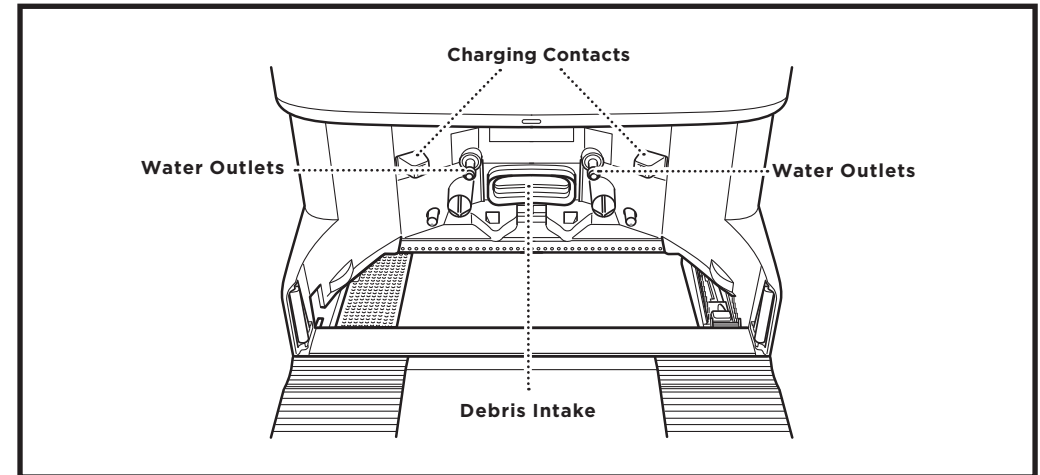

1. Locate the charging contacts, water outlets, and debris intake.
2. With a dry cloth, gently dust off both charging contacts on the base. Remove any dust or debris from the debris intake.
3. Use a dry cloth to wipe the water outlet nozzles on the base to remove any stuck-on debris or other blockages.

STARTING A BASE SELF-CLEAN CYCLE

Run a base self-cleaning cycle every 6 months or as needed.

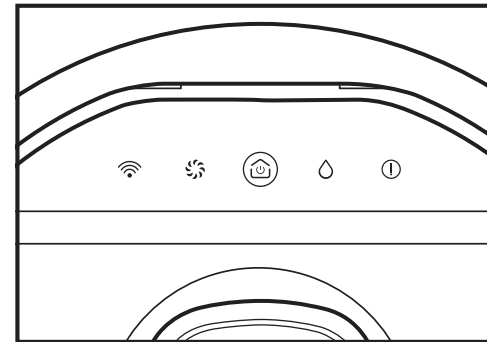

1. Send the robot on mopping mission and allow it to run for at least 5 minutes.
2. While the robot is mopping, empty the clean water and greywater tanks. Fill the clean water tank up to the **YELLOW** fill line with a 1:1 mixture of water and white vinegar.
3. Reinsert both tanks into the base.
4. After 5 minutes of mopping, tap H on the robot to initiate docking.
5. Allow the robot to complete a mop pad wash cycle on the base.
6. Once the wash cycle is complete, empty the contents of both base water tanks into the sink.
7. Remove the robot from the base and power it off by holding the Power/Dock [icon] button for 3 seconds. Remove the water tank and empty it in the sink.
8. Reinstall the water tank on the robot and slide the robot onto the base with the Shark logo facing upside down to power it on.

DO NOT put anything other than 5% white vinegar and water into the water tank when performing a self-clean cycle.

DO NOT use 5% white vinegar unless performing a self-clean cycle.

ROBOT MAINTENANCE

CAUTION: Before performing any maintenance, power off your robot by holding the Power/Dock  button on the robot for 3 seconds, then remove the water tank.

MOP PAD PLATE REMOVAL & REINSTALLATION

Though the base will automatically remove and reinstall the mop pad plate, you can also remove it manually, if needed.

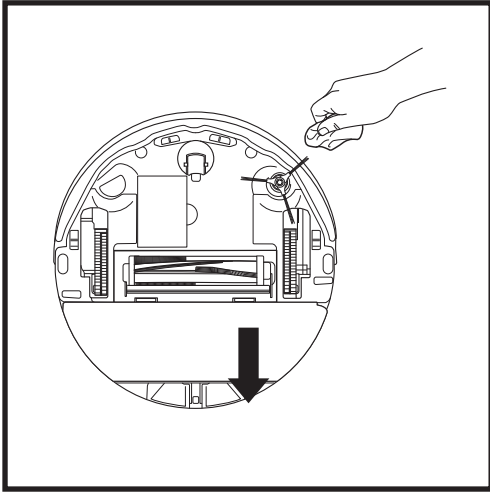

1. To remove the mop pad plate from the bottom of the robot, gently pull on the gray release latch and slide the pad plate off the robot.
2. To reinstall the mop pad plate, slide it back in until it clicks into place.

NOTE: If the pad plate is stuck on the base, gently lift up from the underside of the gray latch to loosen it, then remove.

CLEANING & REPLACING THE MOP PAD

After a wet clean mission, the NeverTouch™ Pro base will automatically wash the robot mop pad. The mop pad should also be cleaned in a washing machine every 3 months or replaced as needed.

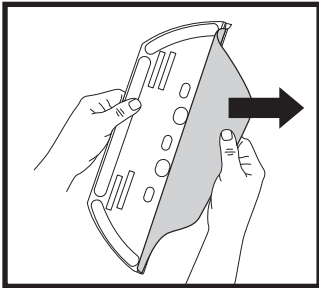

1. Carefully pull the mop pad away from the pad plate.

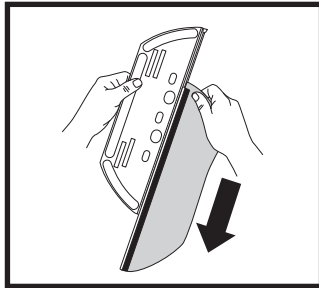

2. Slide the pad off the plate.

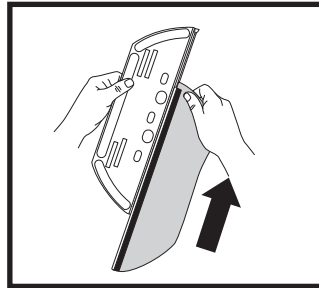

3. Slide a clean or new pad into the edge of the pad plate. Press lightly on the pad to secure it to the plate.

ROBOT MAINTENANCE

CAUTION: Before performing any maintenance, power off your robot by holding the Power/Dock  button on the robot for 3 seconds, then remove the water tank.

EMPTYING THE ROBOT DUST CUP

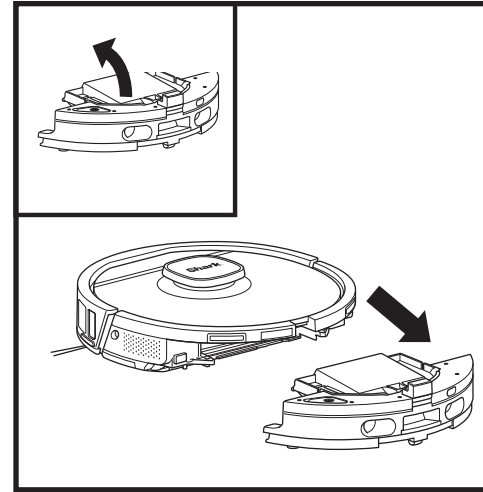

1. Press the dust cup release button and slide the dust cup out from the robot.
2. To open the robot dust cup lid, pinch and lift up using the finger slots.

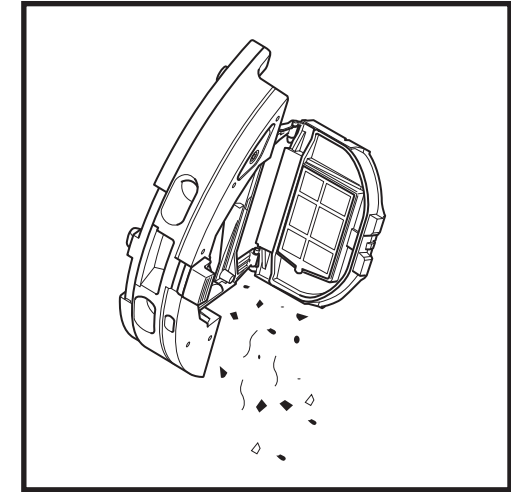

3. Empty the dust cup contents into the trash.
4. Using a dry cloth, wipe the mesh filter on the bottom of the dust cup door.

CLEANING THE ROBOT FILTER

Regularly clean the filters to keep your vacuum's suction power optimal. Replace filters every 6-12 months, or as needed.

IMPORTANT: DO NOT use soap when cleaning the filters.

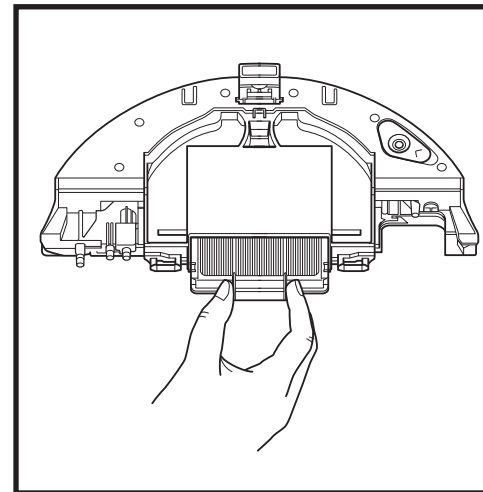

1. Remove the orange filter from the dust cup using the tabs. Lightly tap the filter over the trash to remove debris.
2. Rinse the dust cup with water, and allow it to air-dry for at least 48 hours before reinstalling.
3. Reinsert the filter into the dust cup, then slide the dust cup back into the robot until it clicks into place.

ROBOT MAINTENANCE

CAUTION: Before performing any maintenance, unplug the base from the electrical outlet. Power off the robot by pressing and holding the Power/Dock button on the robot for 3 seconds, then remove the water tank.

CLEANING THE WATER INLETS & OUTLETS

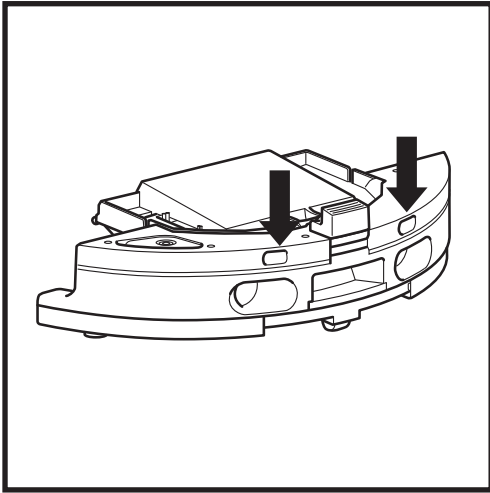

With a dry cloth, wipe the opening of the water inlets on the robot dust bin.

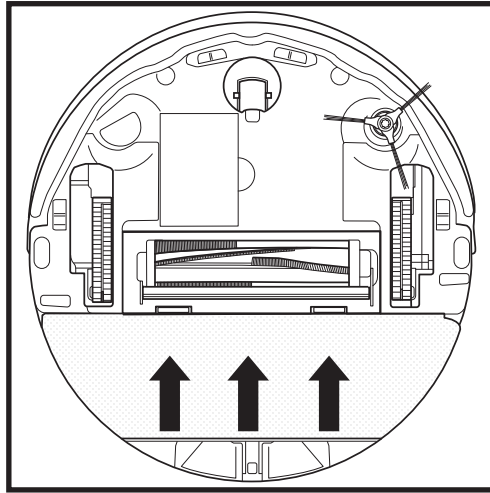

Remove the mop pad plate and clean the three small holes on the bottom of the dust cup with a toothpick or safety pin.

FILLING THE ROBOT WATER TANK

Though the base will automatically refill the robot water tank, you can also access and fill it manually, if needed.

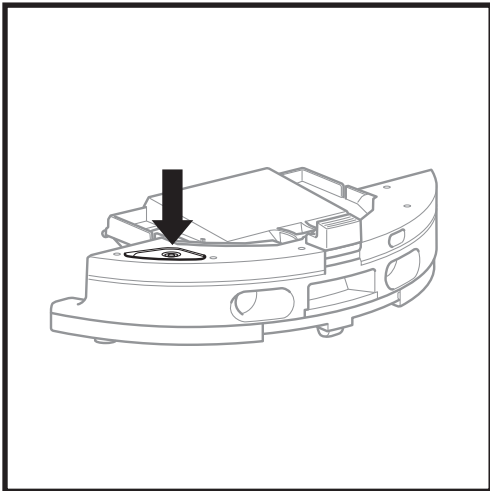

1. To fill the tank, open the port by pulling out the blue rubber seal. Add water through the port, then push the seal back into place.
2. After filling and sealing the robot water tank, be sure to **wipe the robot port dry** with a microfiber cloth.

ROBOT MAINTENANCE

CAUTION: Before performing any maintenance, power off your robot by holding the Power/Dock button on the robot for 3 seconds, then remove the water tank.

CLEANING THE SIDE BRUSH

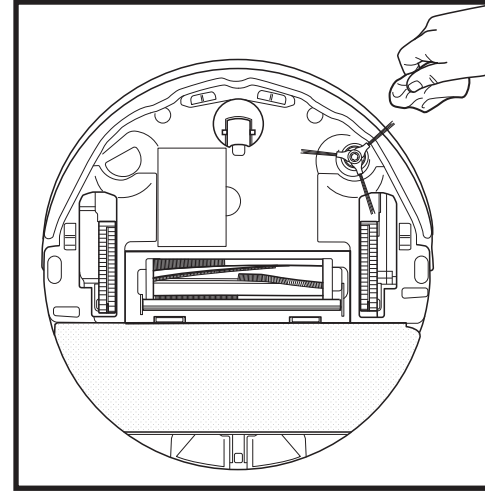

CLEAN SIDE BRUSH AS NEEDED.

1. Pull the side brush off the peg on the bottom of the robot.
2. Carefully unwind and remove any string or hair wrapped around the brush or peg.
3. Gently wipe the brush with a dry cloth. To reinstall, snap the brush over the peg. Spin the brush manually to make sure it is installed correctly.

CLEANING THE BRUSHROLL

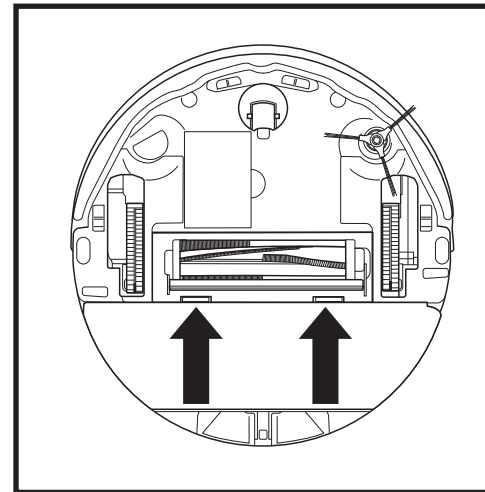

1. To access the brushroll, push up on the tabs on the brushroll door, then lift off the door.

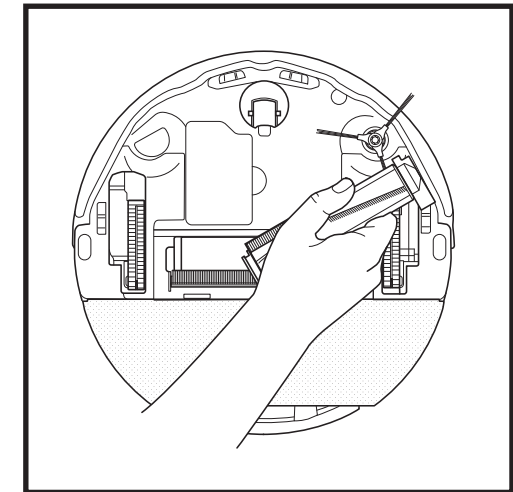

2. Take out the brushroll and remove the cap on the end. Clean off any hair or debris, then replace the cap. Use a dry cloth to clean any debris or hair buildup in the brushroll cavity. Reinstall the brushroll, inserting the flat end first. Close the brushroll access door and press down until both sides click into place.

NOTE: Replace brushroll every 6-12 months, or when visibly worn. See sharkaccessories.com for replacement parts.

ROBOT MAINTENANCE

CAUTION: Before performing any maintenance, power off the robot by pressing and holding the Power/Dock button on the robot for 3 seconds, then remove the water tank.

CLEANING THE DIRT DETECT SENSORS

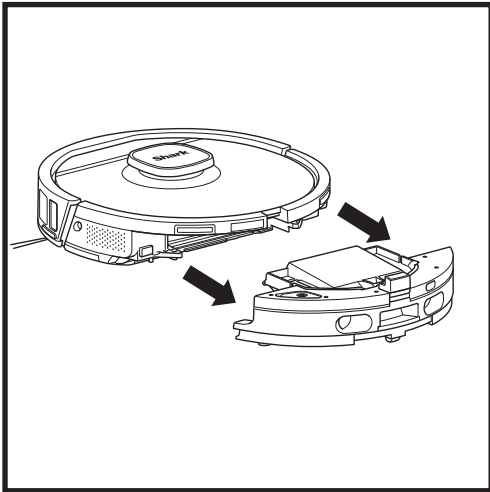

1. Remove the dust bin from your robot.
2. Locate the Dirt Detect sensors. They can be found on the interior of the robot brushroll compartment.

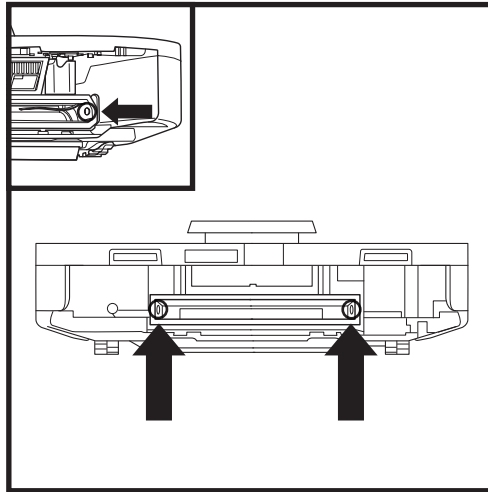

3. With a microfiber cloth, wipe away any debris on the Dirt Detect sensors. There is one sensor on each side of the compartment. **Be sure to clean both sensors.**
4. Make sure there is no debris blocking the opening or wrapped around the brushroll, and reinstall the dust cup.

CLEANING THE SENSORS

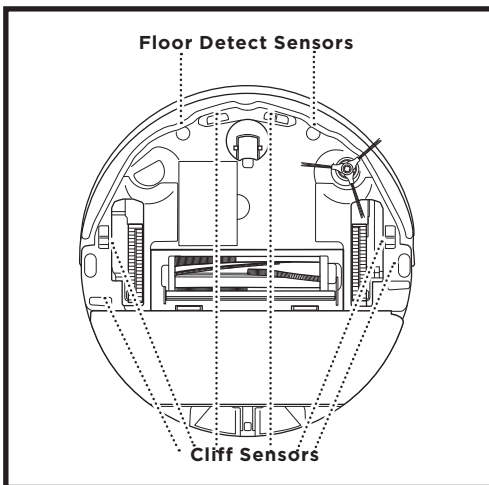

Floor Detect Sensors

Cliff Sensors

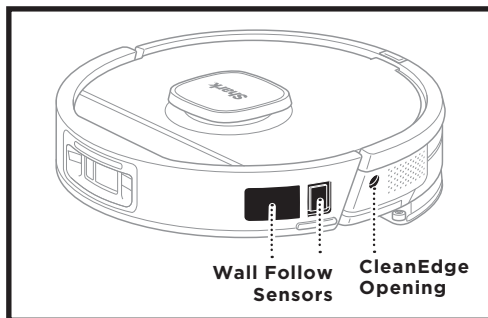

Wall Follow Sensors CleanEdge Opening

CLEAN SENSORS AND CHARGING CONTACTS AS NEEDED.

1. The sensors on the robot require occasional maintenance.
2. With a dry cloth or cotton swab, gently dust off the sensors located on the bottom and sides of the robot.

IMPORTANT: The robot uses cliff sensors to avoid stairs and other steep drops. Sensors may work less effectively when they are dirty. For best results, clean sensors once every 30 days or as needed.

ROBOT MAINTENANCE

CAUTION: Before performing any maintenance, power off the robot by pressing and holding the Power/Dock button on the robot for 3 seconds, then remove the water tank.

LIDAR MODULE

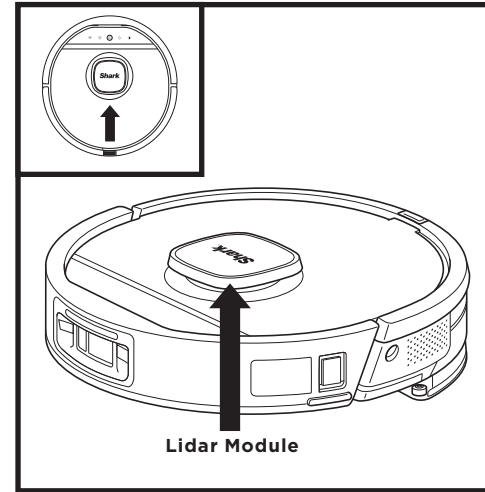

Lidar Module

1. Check the navigation module on top of the robot and gently remove any hair or debris.
2. For a deeper cleaning of the navigation module, first place the robot on a level surface and turn off the power.
3. Use compressed air to blow away any dirt or debris from the gap around the rotating LiDAR turret.
4. Wipe the gap around the turret with a cotton swab while manually rotating the turret 5 times in both directions.

CLEANING THE WHEELS

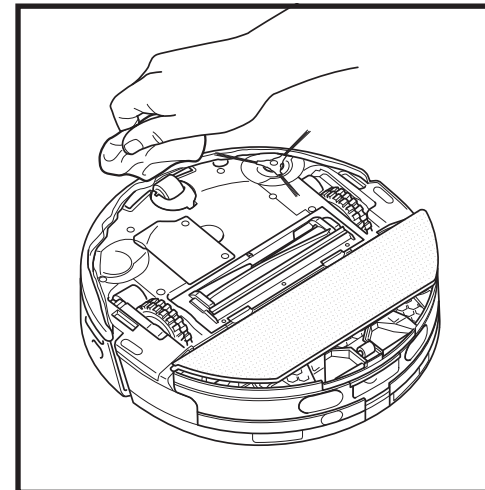

1. Rotate the front wheel while lightly brushing away dirt and debris. Clean the wheel and the housing around it.

CLEAN FRONT WHEEL HOUSING PERIODICALLY.

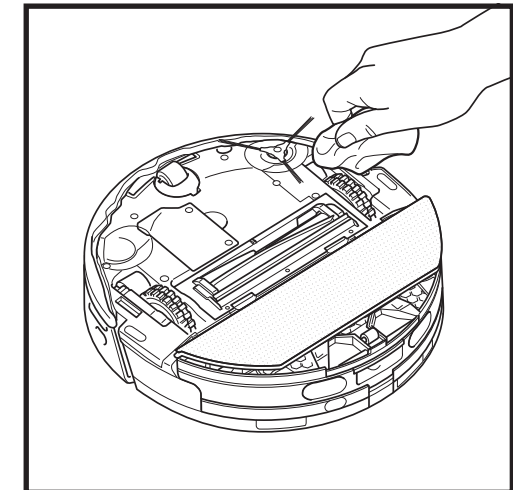

2. Periodically clean the drive wheels and the housing around them. To clean, rotate each drive wheel while dusting.

NOTE: Brush not included.

REMOVING & REINSTALLING THE ROBOT BATTERY

CAUTION: Before performing any maintenance, power off the robot by pressing and holding the Power/Dock button on the robot for 3 seconds, then remove the water tank.

NOTE: You will need a Phillips-head screwdriver (not included) to access the battery.

REMOVING THE ROBOT BATTERY

With a Phillips-head screwdriver (not included) remove the screw(s) securing the battery door on the underside of the robot. Lift off the door and set it aside. **DO NOT** turn the robot right-side-up to allow the battery to drop out of the unit, as this could cause damage. Instead, grip the pull tabs on the battery and lift it out, then place the battery on the flat underside of the robot with the wire still connected. Pinch the white connector where the battery wire meets the robot, and pull up to unplug the battery pack from the robot.

INSTALLING THE ROBOT BATTERY

Align the white connector at the end of the battery wire with the connection port on the robot, and plug the connector into the port until it clicks securely into place. Insert the battery into its compartment with the pull tabs facing up. Replace the battery door and insert the screw(s) into the hole(s) on the door. Use a Phillips-head screwdriver to tighten the screw(s) and secure the door.

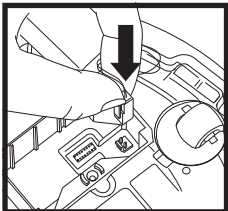
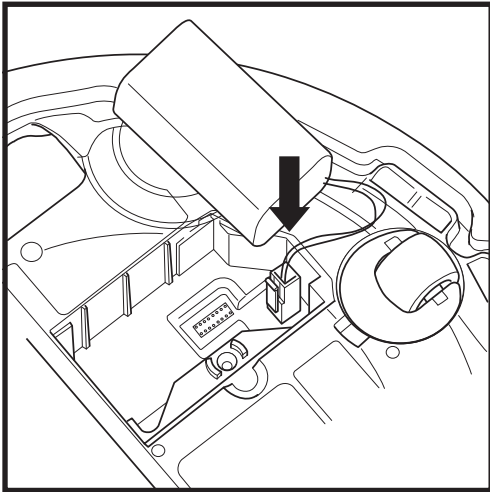
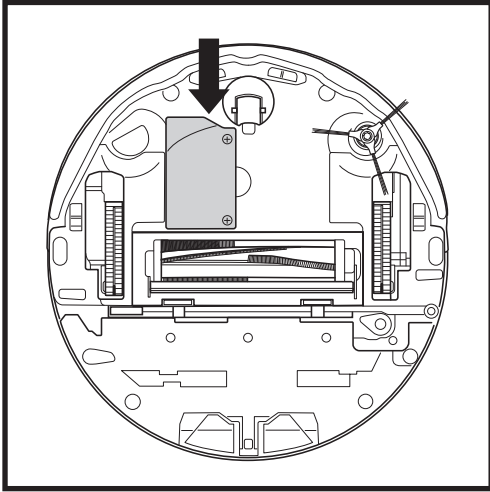

COMMON ERROR CODES

If an error is detected, the lights underneath your robot will illuminate **red** (error) or **orange** (warning). Tap the Error button on your robot to learn more about the error and follow the instructions outlined in the chart below.

ERROR NUMBER	ISSUE	SOLUTION
2	Side brush is stuck.	Remove any debris from around the side brush so it moves freely.
3	Suction motor failure.	Remove and empty the dust bin, clean the filters, remove the brushroll and brushroll door, and remove blockages.
4	Blockage in the brushroll area.	Remove any debris from around the brushroll so that it can spin freely.
5	A drive wheel is stuck.	Clean the wheels and remove any debris wrapped around the axles so they can move freely.
6	Front bumper may be jammed.	Clean the bumper and make sure it moves in and out freely.
7	Cliff sensor error.	Move your robot to a new location and clean its cliff sensors.
9	Robot dust bin needs to be reinstalled.	Insert the dust bin until it clicks in place.
10	Robot may be stuck on an obstacle.	Move robot to a new location on a level surface.
16	Robot is stuck.	Move your robot to a new location and make sure the front bumper moves in and out freely.
23	Robot cannot find the base.	Please make sure the base is powered ON and is free of all obstacles.
24	Battery is critically low and needs recharging.	Please pick up your robot and place it on the base. Make sure the base indicator light turns blue to confirm your robot is placed correctly on the base and is charging.
26	Blockage in dust bin.	Check the debris intake on the base and evacuation port on the robot dust bin for clogs. Clear any debris and reinstall the base dust bin, ensuring that it clicks into place.
33	There may be a blockage with Active Lift.	Turn off the robot and ensure that there is nothing blocking the wheels from moving up and down.
34	There may be a blockage in the base.	Check if the greywater grate is sitting flat and secure in the wash tray.

REPLACEMENT PARTS

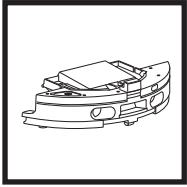

Robot Dust Bin

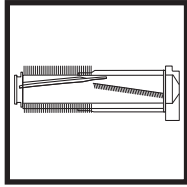

Brushroll

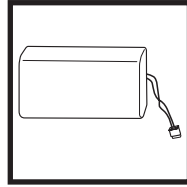

Battery

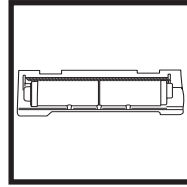

Brushroll Door

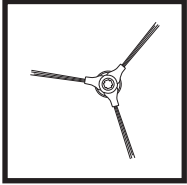

Side Brush

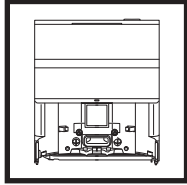

NeverTouch™ Pro Base

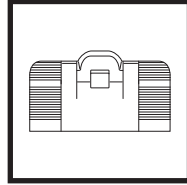

NeverTouch™ Pro Base Ramp

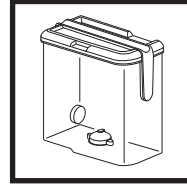

NeverTouch™ Pro Clean Water Tank

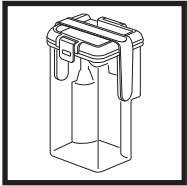

NeverTouch™ Pro Greywater Tank

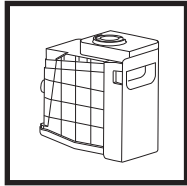

Base Dust Bin

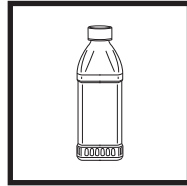

Shark® Multi-Surface Cleaner

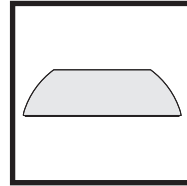

Mopping Pad

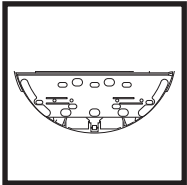

Mop Pad Plate

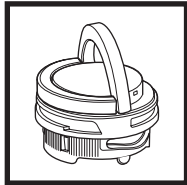

Odor Neutralizer Cartridge

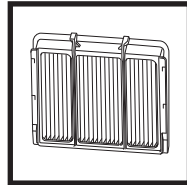

Robot Pre-Motor Filter

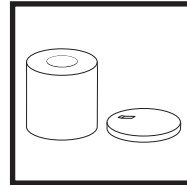

Base Pre-Motor Filters

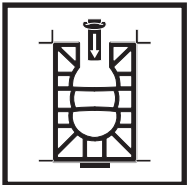

Base Post-Motor Filter (HEPA)

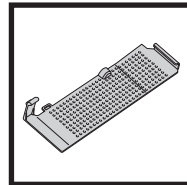

Greywater Grate

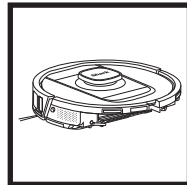

Robot Pod

Questions or Problems?

CALL US: **1-888-668-9600**

Toll-free customer support line

GET HELP RIGHT NOW!
DON'T RETURN TO THE STORE.

Other easy ways to get help RIGHT NOW:

ONLINE HELP AND FAQs:



support.sharkninja.com

APP DOWNLOAD:



Search "SharkNinja" in the app store, or scan the QR code with your smartphone camera.



Download and install the SharkNinja® app

HOW-TO VIDEOS:



youtube.com/shark

CONTACT US:



@sharkhomeuk

Contact us on social media

To order replacement parts visit sharkninja.com/parts-support/home-cleaning-parts/robot-vacuums.

IMPORTANT: PLEASE READ THE TERMS AND CONDITIONS OF THIS LICENSE AGREEMENT CAREFULLY BEFORE CONTINUING WITH THIS PROGRAM INSTALL OR USE OF THIS PRODUCT: SharkNinja Operating LLC's ("SharkNinja") End-User License Agreement ("EULA") is a legal agreement between You (either a single entity or an individual) and SharkNinja for SharkNinja's Software Applications, including those installed by You onto your SharkNinja products or already installed on your device, including all firmware (referred hereafter as "SN APPS"). By installing, copying, checking a box, clicking a button confirming your agreement to these terms, or otherwise continuing to use the SN APPS, You agree to be bound by the terms of this EULA. This license agreement represents the entire agreement concerning SN APPS between You and SharkNinja, and it supersedes any prior proposal, representation, or understanding between the parties. If You do not agree to the terms of this EULA, do not install or use the SN APPS or this product.

The SN APPS are protected by copyright laws and international copyright treaties, as well as other intellectual property laws and treaties.

1. GRANT OF LICENSE. The SN APPS are licensed as follows:

1.1 Installation and Use. SharkNinja grants You the right to download, install, and use SN APPS on the specified platform for which the SN APP was designed and in connection with SharkNinja products with which the SN APPS are designed to operate ("SN Devices").

1.2 Backup Copies. You may also make a copy of SN APPS downloaded and installed by You for backup and archival purposes.

2. DESCRIPTION OF OTHER RIGHTS AND LIMITATIONS.

2.1 Maintenance of Copyright Notices. You must not remove or alter any copyright notices on any and all copies of the SN APPS.

2.2 Distribution. You may not distribute copies of the SN APPS to third parties.

2.3 Prohibition on Reverse Engineering, Decompilation, and Disassembly. You may not reverse engineer, decompile, or disassemble SN APPS, except and only to the extent that such activity is expressly permitted by applicable law notwithstanding this limitation.

2.4 Rental. You may not rent, lease, or lend SN APPS without written permission from SharkNinja.

2.5 NOT FOR RESALE SOFTWARE. Applications identified as "Not for Resale" or "NFR," may not be resold, transferred, or used for any purpose other than demonstration, test, or evaluation.

2.6 Support Services. SharkNinja may provide You with support services related to SN APPS ("Support Services"). Any supplemental software code provided to You as part of the Support Services shall be considered part of SN APPS and subject to the terms and conditions of this EULA.

2.7 Compliance with Applicable Laws. You must comply with all applicable laws regarding use of SN APPS.

3. UPDATES. SharkNinja may provide You with upgrades or updates to SN APPS. This EULA will govern any upgrades provided by SharkNinja that replace and/or supplement SN APPS, unless such upgrade is accompanied by a separate EULA, in which case the terms of that EULA will govern. If You decide not to download and use an upgrade or update provided by SharkNinja, You understand that You could put SN Apps at risk to serious security threats or cause SN Apps to become unusable or unstable.

4. DATA AND PRIVACY. SharkNinja is committed to ensuring your privacy by adhering to high standards of fairness and integrity. We are committed to keeping our customers informed about how we use the information we gather from You through the use of each of our websites or SN APPS. Our privacy practices are described in SharkNinja's Privacy Policy, as well as in separate notices given when an app, product, or service is purchased or downloaded. By using SN APPS or providing us with your personal information, You are accepting and consenting to the practices, terms, and conditions described in SharkNinja's Privacy Policy. At all times your information will be treated in accordance with the SharkNinja Privacy Policy, which is incorporated by reference into this EULA and can be viewed at the following URL: <http://www.sharkninja.com/privacypolicy>.

5. THIRD-PARTY APPLICATION LIBRARIES AND EMBEDDED SOFTWARE.

5.1 You acknowledge that Amazon Web Services, Inc. ("AWS") has provided certain application libraries that have been embedded into SN APPS ("AWS Application Libraries") and enables SN Devices to connect to the AWS Cloud Service ("AWS Embedded Software").

5.2 You will not use the AWS Application Libraries except as an incorporated portion of SN APPS, unmodified from the form provided to You.

5.3 You will not use the AWS Embedded Software except as an incorporated portion of SN Devices, unmodified from the form provided to You.

5.4 You will not modify, adapt, translate, or create derivative works based on, or decompile, disassemble, reverse engineer, or otherwise attempt to derive the source code or underlying algorithms of, the AWS Application Libraries or the AWS Embedded Software.

5.5 SharkNinja retains all ownership of SN APPS (and the AWS Application Libraries contained therein) and any software installed on SN Devices (including the AWS Embedded Software) and only a license thereto is granted to You for use in connection with the SN APPS and SN Devices.

5.6 You will not use the AWS Application Libraries or AWS Embedded Software to attempt to gain unauthorized access to or use of the systems/services of SharkNinja's other licensors; nor will You transmit viruses, worms, Trojan horses, time bombs, spyware, malware, cancelbots, passive collection mechanisms, robots, data mining software, or any other malicious or invasive code or program into the systems/services of SharkNinja's other licensors.

5.7 You will not use the AWS Application Libraries or AWS Embedded Software to interfere with, breach, or circumvent any security feature, authentication feature, or any other feature that restricts or enforces limitations on the use of, or access to, the systems/services of SharkNinja's other licensors.

5.8 You will not probe, attack, scan, or test the vulnerability of the systems/services of SharkNinja's other licensors.

5.9 SharkNinja's other licensors of the SN APPS, AWS Application Libraries, and the AWS Embedded Software are the express third-party beneficiaries of this EULA, and the provisions of this Section of this EULA are made expressly for the benefit of such licensors, and are enforceable by such licensors.

6. TERMINATION. Without prejudice to any other rights, SharkNinja may terminate this EULA if You fail to comply with the terms and conditions of this EULA. In such event, You must destroy all copies of SN APPS in your possession.

7. COPYRIGHT. All title, including but not limited to copyrights, in and to SN APPS and any copies thereof are owned by SharkNinja or its suppliers. All title and intellectual property rights in and to the content which may be accessed through use of SN APPS are the property of the respective content owner and may be protected by applicable copyright or other intellectual property laws and treaties. This EULA grants You no rights to use such content. All rights not expressly granted are reserved by SharkNinja.

8. OPEN SOURCE SOFTWARE. You hereby acknowledge that SN APPS may contain software that is subject to "open source" or "free software" licenses ("Open Source Software"). The license granted by this EULA does not apply to Open Source Software contained in the SN APPS. Rather, the terms and conditions in the applicable Open Source Software license shall apply to the Open Source Software. Nothing in this EULA limits your rights under, or grants You rights that supersede, any Open Source Software license. You acknowledge that the Open Source Software license is solely between You and the applicable licensor of the Open Source Software. To the extent the terms of the licenses applicable to the Open Source Software require SharkNinja to provide the Open Source Software, in either source or executable form, or to provide copies of applicable license terms or other required information, You may obtain a copy of the software by contacting SharkNinja at the below physical address. Additional information about the Open Source Software, and its terms of use, may be found at www.sharkninja.com/opensource.

9. NO WARRANTIES. SharkNinja expressly disclaims any warranty for SN APPS, AWS Application Libraries, or AWS Embedded Software. SN APPS, AWS Application Libraries, and AWS Embedded Software are provided 'As Is' without any express or implied warranty of any kind, including but not limited to any warranties of merchantability, noninfringement, fitness of a particular purpose, or title. SharkNinja does not warrant or assume responsibility for the accuracy or completeness of any information, text, graphics, links, or other items contained within the SN APPS. SharkNinja makes no warranties respecting any harm that may be caused by the transmission of a computer virus, worm, logic bomb, or other such computer program. SharkNinja further expressly disclaims any warranty or representation to any third party.

10. LIMITATION OF LIABILITY. In no event shall SharkNinja or its suppliers be liable for any special, incidental, punitive, indirect, or consequential damages whatsoever (including, but not limited to, damages for loss of profits or confidential or other information, for business interruption, for personal injury, for loss of privacy, for failure to meet any duty including of good faith or of reasonable care, for negligence, and for any other pecuniary or other loss whatsoever) arising out of or in any way related to the use of or inability to use SN Devices or SN APPS, the provision of or failure to provide support or other services, information, software, and related content through the product or otherwise arising out of the use of SN APPS, or otherwise under or in connection with any provision of this EULA, even in the event of the fault, tort (including negligence), strict liability, breach of contract, or breach of warranty of SharkNinja or any supplier, and even if SharkNinja or any supplier has been advised of the possibility of such damages. SharkNinja shall have no liability with respect to the content of the SN APPS or any part thereof, including but not limited to errors or omissions contained therein, libel, infringements of rights of publicity, privacy, trademark rights, business interruption, personal injury, loss of privacy, moral rights, or the disclosure of confidential information.

11. APPLICABLE LAW. The laws of the Commonwealth of Massachusetts will govern this EULA and You hereby consent to exclusive jurisdiction and venue in the state and federal courts sitting in the Commonwealth of Massachusetts.

12. ASSIGNMENT. SharkNinja may assign this EULA without notice to Licensor.

13. ENTIRE AGREEMENT. This EULA (including any addendum or amendment to this EULA which is included with the SN Devices) is the entire agreement between You and SharkNinja relating to the SN APPS and supersedes all prior or contemporaneous oral or written communications, proposals and representations with respect to the SN APPS or any other subject matter covered by this EULA. To the extent the terms of any SharkNinja policies or programs for support services conflict with the terms of this EULA, the terms of this EULA shall control.

If You have questions regarding this EULA, please contact SharkNinja at 89 A Street, Suite 100, Needham, MA 02494.



TWO (2) YEAR LIMITED WARRANTY

The Two (2) Year Limited Warranty applies to purchases made from authorized retailers of **SharkNinja Operating LLC**. Warranty coverage applies to the original owner and to the original product only and is not transferable.

SharkNinja warrants that the unit shall be free from defects in material and workmanship for a period of two (2) year from the date of purchase when it is used under normal household conditions and maintained according to the requirements outlined in the Owner's Guide, subject to the following conditions and exclusions:

CALIFORNIA RESIDENTS ONLY: The two (2) Year Limited Warranty period begins on the original date of delivery or pickup.

What is covered by this warranty?

- The original unit and/or non-wearable components deemed defective, in SharkNinja's sole discretion, will be repaired or replaced with a new or refurbished unit of the same or equivalent model, up to one year from the original purchase date.
- In the event a replacement unit is issued, the warranty coverage ends six (6) months following the receipt date of the replacement unit or the remainder of the existing warranty, whichever is later. SharkNinja reserves the right to replace the unit with one of equal or greater value.

What is not covered by this warranty?

- Normal wear and tear of wearable parts (e.g., not cleaning the filters, not removing debris from the brushroll), which require regular maintenance and/or replacement to ensure the proper functioning of your unit, are not covered by this warranty. Replacement parts are available for purchase at sharkaccessories.com.
- Any unit that has been tampered with or used for commercial purposes.
- Damage caused by misuse (e.g., vacuuming up water or other liquids), abuse, negligent handling, failure to perform required maintenance (e.g., not cleaning the filters, not removing debris from the brushroll), or damage due to mishandling in transit.
- Consequential and incidental damages.
- Defects caused by repair persons not authorized by SharkNinja. These defects include damages caused in the process of shipping, altering, or repairing the SharkNinja product (or any of its parts) when the repair is performed by a repair person not authorized by SharkNinja.
- Products purchased, used, or operated outside North America.

How to get service

If your appliance fails to operate properly while in use under normal household conditions within the warranty period, visit sharkninja.com/support for product care and maintenance self-help. Our Customer Service Specialists are also available at **1-888-668-9600** to assist with product support and warranty service options, including the possibility of upgrading to our VIP warranty service options for select product categories. Please register your product and have it with you when contacting Customer Service.

SharkNinja will cover the cost for the customer to send in the unit to us for repair or replacement. A fee of \$25.95 (subject to change) will be charged when SharkNinja ships the repaired or replacement unit.

How to initiate a warranty claim

You must call **1-888-668-9600** to initiate a warranty claim. You will need the receipt as proof of purchase. A Customer Service Specialist will provide you with return and packing instruction information.

How state law applies

This warranty gives you specific legal rights, and you also may have other rights that vary from state to state. Some states do not permit the exclusion or limitation of incidental or consequential damages, so the above may not apply to you.

ROBOT VACUUM WARRANTY COVERAGE & PARTS GUIDE

NOTE: Warranty covers manufacturing defects, internal hardware or software malfunctions, and structural failures caused by manufacturing defects. It does not cover damage from misuse, accidents, or unauthorized repairs, normal wear and tear, or consumable parts (unless defective upon first use). Please refer to the table below to understand what parts are covered by warranty.

Robot Pod	Clean sensors and charging contacts monthly, or as needed.	N/A	Non-Wearable	Yes
Brushroll	Clean monthly, or as needed.	Every 6-12 months, or as needed.	Wearable	No (unless defective)
Filter	Clean monthly, or as needed.	Every 6-12 months, or as needed.	Wearable	No
Dust Cup	Clean monthly, or as needed.	As needed.	Wearable	No (unless defective)
Mop Pad	After every wet cleaning mission, the base will automatically wash and dry the mop pad. Additional cleaning in a washing machine may be needed occasionally.	Every 2 years, or as needed.	Wearable	No
Side Brush	Clean monthly, or as needed.	Every 3-6 months, or as needed.	Wearable	No (unless defective)
Battery	N/A	Every 12-24 months, or as needed.	Wearable	Yes (within warranty)

Multi-functional Base	Clean monthly, or as needed.	N/A	Non-Wearable	Yes
Dust Bin	Empty every 60 days, or as needed.	As needed.	Wearable	No (unless defective)
Pre-Motor Filters	Clean monthly, or as needed.	Every 6-12 months, or as needed.	Wearable	No
Post-Motor Filter (HEPA)	Clean every 6 months, or as needed.	Once a year, or as needed.	Wearable	No
Ramp	Clean monthly, or as needed.	As needed.	Wearable	No (unless defective)
Greywater Grate	Clean every 30 days, or as needed.	As needed.	Wearable	No (unless defective)

REGISTER YOUR PURCHASE



registeryourshark.com



NOTES

RECORD THIS INFORMATION

Model Number: _____

Date of Purchase: _____
(Keep receipt)

Store of Purchase: _____

TIP: You can find the model and serial numbers on the QR code labels on the bottom of the robot and Self-Empty Base.

EXPECTED PERFORMANCE

Expected runtime: 120 minutes

Expected charging time: 4 hours



FCC WARNINGS

This equipment has been tested and found to comply with the limits for a Class B digital device, pursuant to parts 15 of the FCC Rules. These limits are designed to provide reasonable protection against harmful interference in a residential installation. This equipment generates, uses, and can radiate radio frequency energy and, if not installed and accordance with the instructions, may cause harmful interference to radio communications. However, there is no guarantee that interference will not occur in a particular installation. If this equipment does cause harmful interference to radio or television reception, which can be determined by turning the equipment off and on, the user is encouraged to try to correct the interference by one or more of the following measures:

- Reorient or relocate the receiving antenna.
- Increase the separation between the equipment and receiver.
- Connect the equipment into an outlet on a circuit different from that to which the receiver is connected.
- Consult the dealer or an experienced radio/TV technician for help.

This Device complies with part 15 of the FCC rules. Operation is subject to the following conditions:

- 1 This device may not cause harmful interference
- 2 This device must accept any interference received, including interference that may cause undesired operation.

Changes or modifications not expressly approved by the party responsible for compliance could void the user's authority to operate this device.



BATTERY REMOVAL AND DISPOSAL

This product uses a battery. When the battery no longer holds a charge, it should be removed from the vacuum and recycled. **DO NOT** incinerate or compost the battery.

When your lithium-ion battery needs to be replaced, dispose of it or recycle it in accordance with local ordinances or regulations. In some areas, it is illegal to place spent lithium-ion batteries in the trash or in a municipal solid waste stream. Return spent battery to an authorized recycling center or to retailer for recycling. Contact your local recycling center for information on where to drop off the spent battery.

For more information on battery removal for disposal, please visit sharkninja.com/batterysupport.

The RBRC™ (Rechargeable Battery Recycling Corporation) seal on the lithium-ion battery indicates that the costs to recycle the battery at the end of its useful life have already been paid by SharkNinja. In some areas, it is illegal to place spent lithium-ion batteries in the trash or municipal solid waste stream and the RBRC program provides an environmentally conscious alternative.

RBRC, in cooperation with SharkNinja and other battery users, has established programs in the United States and Canada to facilitate the collection of spent lithium-ion batteries. Help protect our environment and conserve natural resources by returning the spent lithium-ion battery to an authorized SharkNinja service center or to your local retailer for recycling. You may also contact your local recycling center for information on where to drop off the spent battery. You can email RBRC, recycling@rbrc.com, or call RBRC toll free at (877) 723-1297 with questions about the program, to sign up, or to order program materials. You can also find rechargeable battery recycling drop-off locations near you by visiting www.rbrc.org online.

PLEASE READ CAREFULLY AND KEEP FOR FUTURE REFERENCE.

This Owner’s Guide is designed to help you keep your Shark® PowerDetect™ UV Reveal™ robot running at peak performance.

SharkNinja Operating LLC

US: 89 A St #100, Needham, MA 02494

CAN: 4400, Chemin du Bois-Franc, Montreal, QC H4R 2K9

1-888-228-5531

sharkninja.com

Illustrations may differ from actual product. We are constantly striving to improve our products; therefore the specifications contained herein are subject to change without notice.

This product may be covered by one or more U.S. patents. See sharkninja.com/patents for more information.

© 2026 SharkNinja Operating LLC. SHARK and SHARKNINJA are registered trademarks of SharkNinja Operating LLC. NEVERSTUCK, NEVERTOUCH, POWERDETECT, and THERMACHARGED are trademarks of SharkNinja Operating LLC. RBRC is a trademark of Rechargeable Battery Recycling Corporation. APPLE, the Apple logo, and iPhone are trademarks of Apple Inc., registered in the U.S. and other countries. APP STORE is a service mark of Apple Inc., registered in the U.S. and other countries. GOOGLE, GOOGLE ASSISTANT, GOOGLE PLAY, the Google Play logo, and Android are trademarks of GOOGLE LLC.



@sharkhome