

# total gym 1600

## Owner's Manual

*For maximum effectiveness and safety,  
please read this owner's manual and  
view the video before using your  
Total Gym 1600.*



# Table of Contents

<b>EQUIPMENT WARNING / CAUTION LABELS .....</b>	<b>3</b>
<b>SAFETY INSTRUCTIONS.....</b>	<b>3</b>
<b>PRODUCT SPECIFICATIONS .....</b>	<b>4</b>
<b>SET UP .....</b>	<b>5-6</b>
<b>ACCESSORIES: HOW TO'S .....</b>	<b>7-9</b>
Multi Function Attachments .....	7-8
Dip Bars .....	8
Leg Pulley.....	9
<b>STARTING OUT .....</b>	<b>10</b>
<b>INSPECTION, MAINTENANCE &amp; STORAGE .....</b>	<b>11-12</b>
<b>PARTS OVERVIEW &amp; LIST .....</b>	<b>13-14</b>

# Congratulations on purchasing your new Total Gym®

With this product in your home, you have everything you need to start your own workout program, to tone and strengthen the important muscle groups of your upper and lower body. This is vital for all of us, regardless of age, sex, or fitness level, and regardless of whether your primary goal is body sculpting, weight loss, health maintenance, or more energy for daily activities.

Strength training not only tones and conditions the muscles we use every day to stand, walk, lift, and turn; it can actually transform our body composition. By reducing body fat and increasing the proportion of lean muscle in our bodies, strength training can effectively turn up our metabolic thermostat, so that we burn calories all the time, no matter what we're doing.

It's easy - all you have to do is spend 15 to 20 minutes a day, 3 to 4 days per week on your Total Gym® to start realizing the benefits.

Be sure to read through this Owner's Manual carefully. **It is the authoritative source of information about your Total Gym®.**

## CUSTOMER SERVICE QUESTIONS

If you have questions about your Total Gym®, please call Customer Service at 1-800-303-7896, Monday through Friday, 8:30 am to 5:00 pm, EST.

## ORDERING REPLACEMENT PARTS

When ordering parts, please contact our Parts Department, toll free at 1-800-303-7896, Monday through Friday, 8:30 am to 5:00 pm, EST.

**IMPORTANT:** You must have your serial number and this manual ready when calling for parts.

Serial #: \_\_\_\_\_

## PLEASE ALSO PROVIDE THE FOLLOWING INFORMATION:

1. Name, Mailing Address and Telephone Number
2. Date of Purchase
3. Where Product was Purchased (Name of Retail Store, City)
4. Model Number
5. Part Order Number and Description

# Equipment Warning / Caution Labels

See page 4 for placement of the following warning/caution labels on your unit.

<p><b>WARNING LABEL 1</b></p> <p><b>⚠ WARNING</b></p> <p>FAILURE TO READ AND FOLLOW THE SAFETY INSTRUCTIONS STATED IN THE OWNER'S MANUAL AND VIDEO MAY RESULT IN POSSIBLE SERIOUS INJURY OR DEATH. KEEP CHILDREN AWAY. MAXIMUM USER WEIGHT 250 LBS. REPLACE THIS LABEL IF DAMAGED, ILLEGIBLE OR REMOVED. FOR HOUSEHOLD USE ONLY. CALL CUSTOMER SERVICE AT 1-800-303-7896 FOR REPLACEMENT LABEL, MANUAL, VIDEO OR QUESTIONS.</p>	<p><b>WARNING LABEL 2</b></p> <p><b>⚠ WARNING</b></p> <p>MAKE SURE ADJUSTMENT PIN IS LOCKED IN PLACE BEFORE BEGINNING EXERCISES.</p>	<p><b>WARNING LABEL 3</b></p> <p><b>⚠ WARNING</b></p> <p>BEFORE USING, INSERT SAFETY PIN THROUGH THE HOLE ON THE RIGHT SIDE OF THE HEIGHT ADJUSTMENT ASSEMBLY.</p>	<p><b>WARNING LABEL 4</b></p> <p><b>⚠ WARNING</b></p> <p>CRUSH HAZARD KEEP HANDS CLEAR DURING FOLDING.</p> <p>3 locations</p>	<p><b>WARNING LABEL 5</b></p> <p><b>⚠ WARNING</b></p> <p>BE CAREFUL NOT TO BUMP HEAD WHEN LEG ATTACHMENT IS IN PLACE. REMOVE LEG ATTACHMENT FROM FRAME WHEN NOT REQUIRED FOR THE SPECIFIC EXERCISE.</p> <p>Located on Leg Pulley Bracket</p>
<p><b>WARNING LABEL 6</b></p> <p><b>⚠ WARNING</b></p> <p>PINCH POINT. KEEP HANDS AWAY FROM THE FENDER.</p> <p>4 locations</p>	<p><b>WARNING LABEL 6</b></p> <p><b>⚠ WARNING</b></p> <p>PINCH POINT. KEEP HANDS AWAY FROM THE FENDER.</p> <p>4 locations</p>	<p><b>CAUTION LABEL 1</b></p> <p><b>⚠ CAUTION</b></p> <p>REMOVE MULTI FUNCTION ATTACHMENTS FROM FRAME WHEN NOT REQUIRED FOR THE SPECIFIC EXERCISE.</p> <p>Located on Multi Function Attachment</p>	<p><b>CAUTION LABEL 2</b></p> <p><b>⚠ CAUTION</b></p> <p>KEEP HAIR, FINGERS, LOOSE CLOTHING, PETS, AND CHILDREN AWAY FROM HINGES AND OTHER MOVING PARTS TO AVOID SERIOUS INJURY. ALSO, BE SURE TO HAVE ALL PINS LOCKED IN PLACE BEFORE GETTING ON YOUR TOTAL GYM® TO AVOID SEVERE INJURY.</p>	<p><b>CAUTION LABEL 3</b></p> <p><b>⚠ CAUTION</b></p> <p>REMOVE DIP BAR FROM FRAME WHEN NOT REQUIRED FOR THE SPECIFIC EXERCISE.</p> <p>Located on both Dip bars</p>
				<p><b>CAUTION LABEL 4</b></p> <p><b>⚠ CAUTION</b></p> <p>REMOVE SQUAT STAND FROM FRAME WHEN NOT REQUIRED FOR THE SPECIFIC EXERCISE.</p> <p>Located on Squat Stand pole.</p>

# Safety Instructions

Before beginning this or any exercise program, consult a physician or health professional, who can assist you in planning a program appropriate for your age and physical condition. This is especially important if you are over age 35 or have pre-existing health problems.

**Do not overexert yourself.** Stop exercising immediately and consult your doctor if you experience pain or tightness in your chest, irregular heart beat, shortness of breath, or if you feel faint, nauseous, or dizzy.

**This product is designed for home use only.** It is not intended for commercial or institutional use. Use only as instructed.

**Do not stand on the product.**

**The Total Gym® is not intended for use by children.** Keep this and all fitness equipment out of the reach of children.

**Keep fingers, loose clothing, and hair away from moving parts.**

**Inspect your exerciser before each use to ensure proper operation.** Do not use this equipment unless all moving parts, including cables and pulleys are working properly. See pages 11 & 12 for details on Inspection, Maintenance and Storage.

**The exerciser should only be used on a mat or carpeted surface to prevent unexpected movement of the unit.**

**Use only the accessory items recommended by the manufacturer.**

**To avoid serious injury,** care should be taken at all times when **getting on and off** this or any exercise equipment.

# Product Specifications

## LABEL LOCATIONS AND PARTS IDENTIFIER

Total Gym® 1600 includes Workout DVD

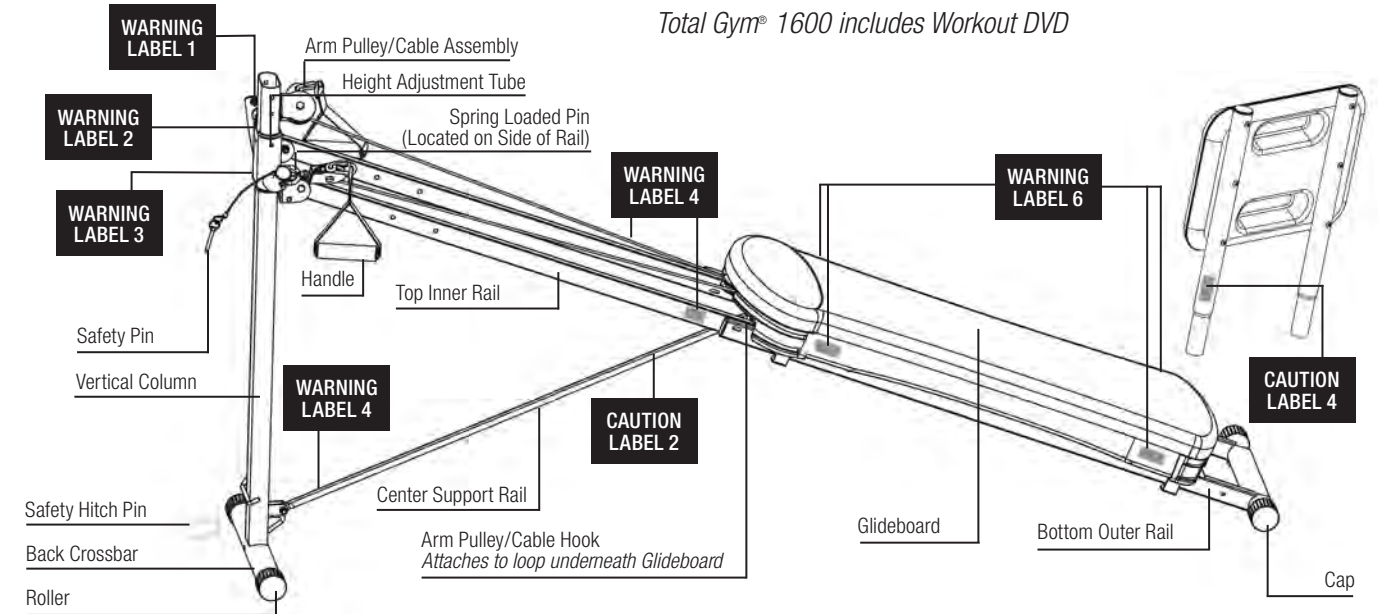

<b>LENGTH</b>	<b>HEIGHT</b>	Width .....
Folded ..... 51"	Folded ..... 8.5"	16"
In Use ..... 92.5"	In Use ..... 43.25"	Weight ..... 75 lbs.
		Maximum User Weight ..... 250 lbs.

## LEG PULLEY ACCESSORY KIT

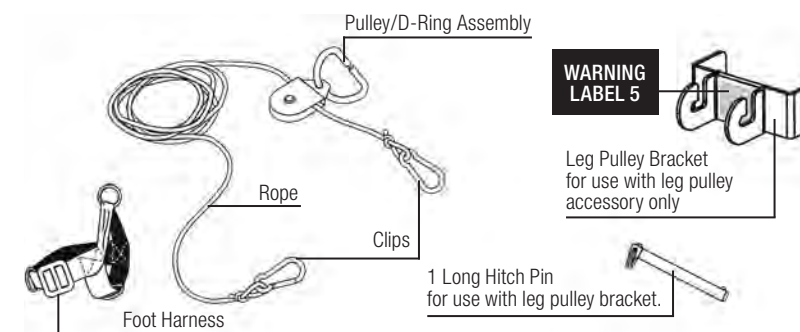

Items shown below are also in Leg Pulley Accessory Kit



## MULTI FUNCTION ATTACHMENTS

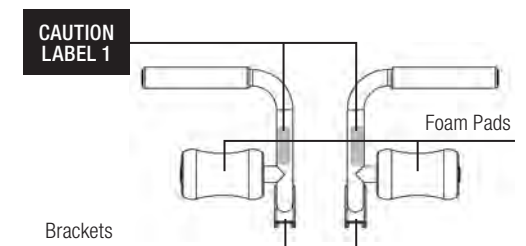

## DIP BARS

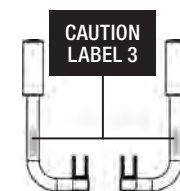

## FLIP CHART

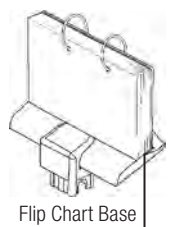

# Set Up

Your product comes with:

- **Safety Hitch Pin** located at the bottom of the Vertical Column, which must be removed prior to unfolding.
- **Height Adjustment Quick Release Pin** located on side of Vertical Column for raising and lowering rails.
- **Spring Loaded Pin** locked into the base of the Left Rail by the Height Adjustment Tube. Left side is determined by standing behind the unit facing the Vertical Column.

**IMPORTANT:** To prevent injury, be sure the Spring Loaded Pin is locked securely into place in the Left Rail before using unit. This will prevent the Height Adjustment Column from falling forward.

- **Safety Pin** located on Lanyard/attached to Height Adjustment Tube.
- **2 Short Hitch Pins** for the Dip Bars and Multi Function Attachments and **1 Long Hitch Pin** for the Leg Pulley Bracket (located in the Miscellaneous Section of the Accessory Kit.)

**IMPORTANT:** Before using the Multi Function Attachments, Dip Bars and Leg Pulley Accessory, be sure the Hitch Pins are securely inserted (see pages 7 - 9 of this manual for directions).

1. Pull the product out of the shipping box. Remove all packaging materials, including tape and cardboard inserts, from your unit.  
**NOTE:** Some parts are packed inside the Rails.
2. Lay product on the floor with glideboard side up. Make sure you have plenty of space on both ends of the product. Slide the glideboard as far as it will go towards the Front Crossbar before you begin lifting unit.
3. Lift the exerciser up by holding it at the top of the rails. Using your foot, slowly spread the unit open at the bottom approximately 12 inches so that it rests firmly on the Front and Back Crossbars not allowing it to go too far.

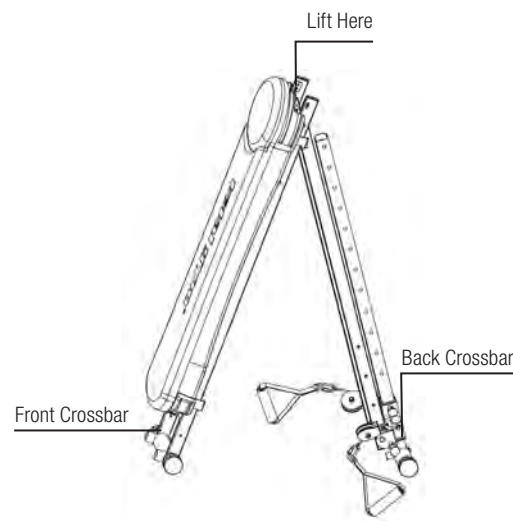

4. Make sure the handles are out to the sides before you begin to unfold your unit. Keep hands and fingers away from pulley. Hold onto the top center of glideboard and begin rolling rear rollers. Spread the unit out until it is flat on the floor. Be careful to do this **slowly**.

**Be sure to support the frame in the center to avoid having the product drop suddenly onto the floor or pinch fingers.**

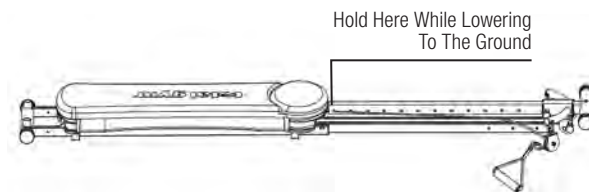

5. **A.** Remove Safety Hitch Pin from bottom of Vertical Column. Next remove plastic packing ties from the top and bottom of the Vertical Column. Pull out the Spring Loaded Pin Knob located at the left rail (**NOTE:** pin shown in picture is on right side) to release Spring Loaded Pin. Continue to hold pin out while performing the next step.

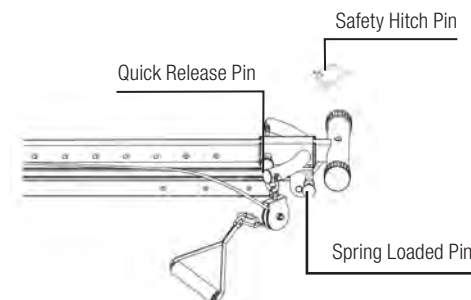

6. **B.** Take hold of the Vertical Column and pull it up until it is upright. Release the Spring Loaded Pin. You should hear it lock back into place.



**IMPORTANT:** Be sure the Spring Loaded Pin is locked into place before using your unit. You will know the pin is locked into place when you can see the end protrude through the inside of the rail bracket.

6. Position one foot on Back Crossbar to keep the product from lifting off the floor. With one hand on either the right or left rail and the other hand holding the Height Adjustment Quick Release Pin out, slide the rails along the Vertical Column to desired position and release pin. Pin will pop into place - you will hear a snap. Last, insert straight Safety Pin (attached to the Height Adjustment Tube) into the hole on Vertical Column just below the Height Adjustment Bracket.

**NOTE:** Insert Safety Hitch Pin in the side hole located at the bottom of the Vertical Column. (This is the pin you removed in step 5A).

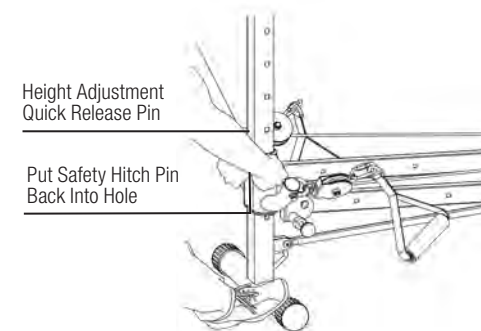

## 8. STOPPER ASSEMBLY

If the Stopper at the bottom of the Vertical Column has not already been installed, please do so now. Locate the Stopper which is packed in Miscellaneous Accessories (See Product Specifications on page 4 of this manual). Unscrew nut on the end of the Stopper and remove. Insert the Stopper into the hole located in the center of the Back Crossbar (See Fig. 1). Screw the nut back onto the Stopper and tighten with Allen Wrenches provided (See Fig. 2).

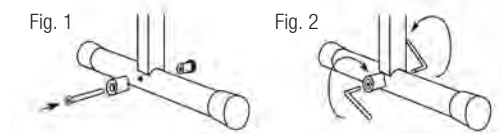

**IMPORTANT:** Proper installation of the Stopper is necessary for the Rollers to function easily when the unit is folded and rolled into place for storage.

## 9. FLIP CHART ASSEMBLY

To add the Flip Chart, insert the Flip Chart Base into the Vertical Column. Then secure the Flip Chart onto the Flip Chart Base.

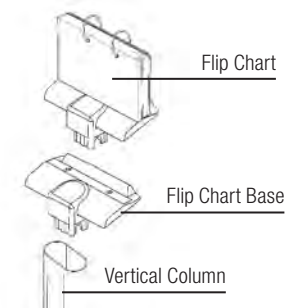

## How to Attach the Multi Function Attachments

The Multi Function Attachments provided with your unit has been uniquely designed to serve several purposes. It can be placed at the top or bottom of the exerciser and angled toward you or away from you depending upon what is comfortable for you.

Two thick Foam Pads are provided with the Multi Function Attachments. They must be attached to the Attachments (if not already) before exercising. To do this:

1. Simply wet each crossbar with soapy water.
2. Then attach Foam Pads on the Crossbars as shown in Figure 1. Let dry before beginning to exercise with the Multi Function Attachments.

Below are instructions on how to position the Multi Function Attachments in accordance with the exercises you wish to do.

**NOTE:** Hitch Pins are included in Miscellaneous Parts. The Right and Left Multi Function Attachments can be placed on opposite rails depending on the exercise. Always keep the Foam Pads to the outside of the Rails.

### PULL UPS AND CHIN UPS

1. Locate the holes at the top of the Right and Left Rails.
2. With the Multi Function Attachments angled **toward** the Glideboard, line up the Brackets on the Attachments with the desired position holes on the Rails.
3. Insert the 2 Short Hitch Pins through the holes on the Multi Function Attachment Brackets and the hole on the Rails, as shown in Figure 2.
4. You are now ready to perform Pull Up and Chin Up exercises to work the arms, lats and back. See your Exercise Guide for specific exercises.

### SQUATS

*Squat Stand can be used instead of Multi Function Attachments*

1. Locate the holes at the bottom of the Right and Left Rails.
2. With the Multi Function Attachments angled away from the Glideboard, line up the Brackets on the Attachments with the holes on the Rails.
3. Insert the 2 Short Hitch Pins through the holes on the Multi Function Attachment Brackets and the hole on the Rails, as shown in Figure 4.
4. You are now ready to perform the Squat which works the thighs and calves. See your Exercise Booklet for specific exercises.

**NOTE:** When performing the Squat exercises, be sure to position your hands on the side of the Glideboard, **NOT** along the bottom of the Glideboard in order to avoid pinched fingers

### LEG PULL, CRUNCHES AND SIT UPS

1. Locate the holes at the top of the Right and Left Rails.
2. With the Multi Function Attachments angled **away from** the Glideboard, line up the Brackets on the Attachments with the desired position holes on the Rails.
3. Insert the 2 Short Hitch Pins through the holes on the Multi Function Attachment Brackets and the hole on the Rails, as shown in Figure 3.
4. You are now ready to perform Leg Pulls, Crunches and Sit Up exercises to work the abdominals, waist and legs. See your *Exercise Booklet* for specific exercises.

### FRONT PRESS

1. Locate the holes at the bottom of the Right and Left Rails near the Front Crossbar.
2. With the Multi Function Attachments toward the Glideboard, line up the Brackets on the Attachments with the holes on the Rails.
3. Insert the 2 Short Hitch Pins through the holes on the Multi Function Attachment Brackets and the hole on the Rails, as shown in Figure 5.
4. You are now ready to perform the Front Press exercise which works the upper chest and triceps. See your Exercise Booklet for specific exercises.

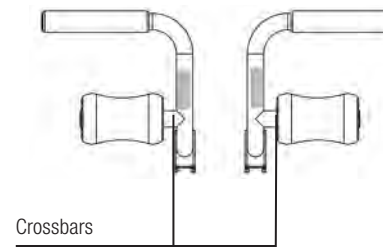

FIGURE 1

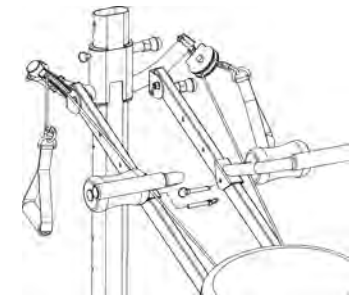

FIGURE 2

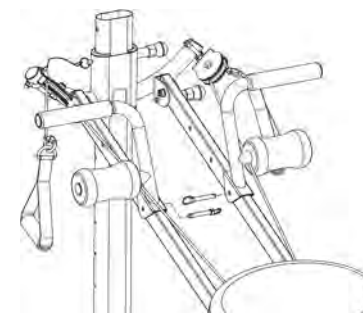

FIGURE 3

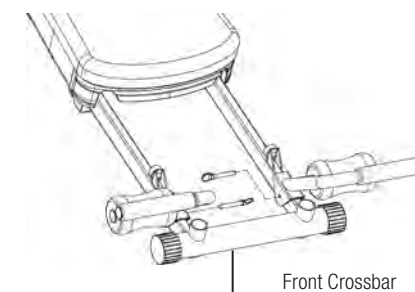

FIGURE 4

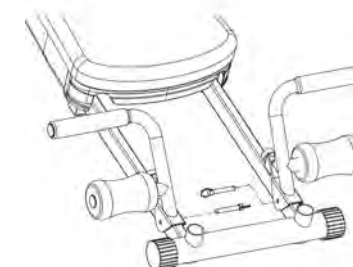
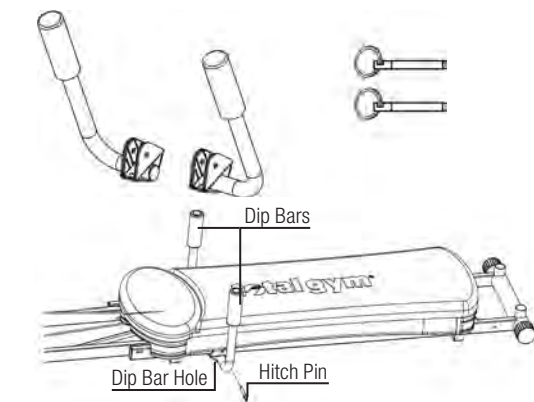

FIGURE 5

## How to Attach the Dip Bars

1. Attach each Dip Bar to the frame with the Short Hitch Pins included with your Total Gym®. **Note: Hitch Pins are included in Miscellaneous Parts.** Simply line up each bar with the holes in the upper portion of the bottom frame.
2. Slide one Short Hitch Pin through the hole of one of the Dip Bars and through the frame. Repeat Steps 1 and 2 for attaching the other Dip Bar. **Make sure to securely attach each Dip Bar to each side of the frame before using.** See your Exercise Guide for specific exercise.

**NOTE:** Remove the Dip Bars when you are not exercising with them.



## How to Attach the Leg Pulley Accessory Kit

**NOTE:** Be sure you have plenty of free space around the exerciser so that performing on the Total Gym®, as well as getting on and off, is convenient and safe. Please note that the Rails cannot be raised to the highest position on the Height Adjustment Column when the Leg Pulley Bracket is attached to the column.

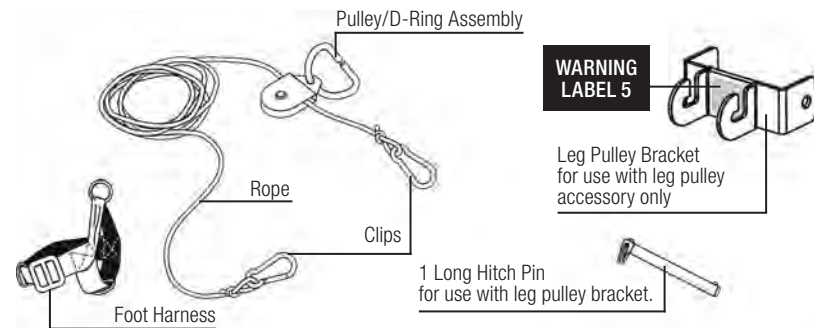

1. Connect the Leg Pulley Bracket to the top of the Vertical Column by aligning Bracket with the hole at the top of the column; be sure bracket is right side up.

Insert Long Hitch Pin through the hole to secure Bracket onto the Vertical Column.

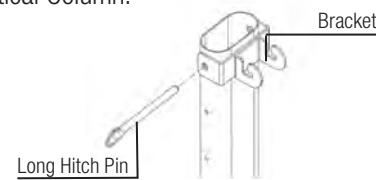

4. Attach the Foot Harness to one of your feet by placing your foot in the Harness so the sewn-in O-ring is on the bottom of your foot. Pull tightly on the strap at the Harness Buckle so the Foot Harness is secure.

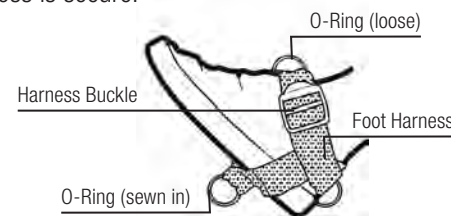

2. Detach the Cable Assembly from the loop on the underside of the glideboard, attach one of the Clips from the Leg Pulley Assembly.

3. Place D-Ring on Pulley first. Then connect the D-Ring to the Bracket as shown.

**NOTE: If rope appears to be twisted, take D-Ring off and turn Pulley around.**

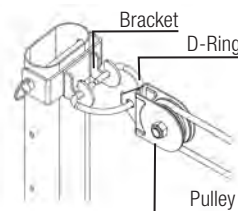

5. **A.** Position yourself on the glideboard correctly for the specific exercise you want to perform.

**B.** While sitting down on the glideboard, bring 1 knee up, connect the Clip on the end of the rope to an O-Ring on the Foot Harness attached to your foot. Depending on the exercise you are performing, connect the Clip to the proper O-Ring. Be sure to always stabilize the glideboard when clipping on or off the Harness. Also, use caution when getting on or off the glideboard. You are now ready to exercise using the Leg Pulley Accessory. See your Exercise Guide for specific exercises that utilize the Leg Pulley Accessory.

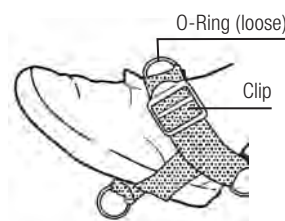

**NOTE: Remove Leg Pulley Bracket when you are not exercising with it.**

**B.** To disconnect the Foot Harness, unclip the rope from the O-Ring on the Harness. Be sure to stabilize glideboard when disconnecting Foot Harness.

## Starting Out

### GENERAL SAFETY TIPS

- While performing exercises with quick tempo repetitions, the Total Gym® may move. Please be aware of the action and make necessary adjustments as you continue your exercise program.
- Wear athletic shoes and comfortable light clothing when exercising on the Total Gym®.
- Do not exercise barefoot.
- Check your exerciser before using to ensure that all the parts are in place and working properly (*see pages 11 and 12 for details on Inspection, Maintenance and Storage*).
- Adult supervision is required at all times.
- The Rails and Glideboard can be raised to any desired level on the Height Adjustment Column depending upon your degree of fitness. Please note, however, that the Rails cannot be raised to the highest position on the Height Adjustment Column when the Leg Pulley Bracket is attached to the column.
- Be sure you have plenty of free space around the exerciser so that performing on the Total Gym®, as well as getting on and off, is convenient and safe.
- Each time you raise or lower the Height Adjustment Column, be sure you hold it to keep it from dropping to the floor.

### AS EASY AS 1-2-3

Begin using the product at a low incline. As your fitness level progresses, increase the incline to increase the intensity and improve your muscle strength. Don't be in a hurry to exercise at a high intensity level; start out easily and build gradually. The Total Gym® is as easy as 1-2-3 to use, so read on...

#### 1. IMPORTANT THINGS TO REMEMBER WHEN USING THE TOTAL GYM®

- Always have control of the glideboard before getting on and off the exerciser.
- Keep your feet on the floor when getting on and off the exerciser. Only remove them from the floor for the duration of the exercise.
- If you are using the handles, hold onto them as you get on and off the glideboard.
- Remove Cable from Glideboard when not using Cable Handles.

#### 2. EXERCISING WITH THE HANDLES ONLY

Grasp the handles which are attached to the cable and slide the glideboard to a position in which you can comfortably sit or lay down when performing the desired exercise (see the Exercise Guide). Be sure to keep your feet on the floor until you are in the correct position for the specific exercise. Then, if the exercise calls for your feet to be off the floor, place your feet as specified in the instructions.

#### 3. EXERCISING WITH THE MULTI FUNCTION ATTACHMENT AND THE DIP BARS

Slide the glideboard to a position in which you can comfortably sit or lay down on when performing the desired exercise (see the Exercise Guide). Keep your feet on the ground until you are in the correct position and feel comfortable. Then, place your feet in the proper position and begin to exercise.

When starting your exercise program, begin with the basic exercises in the Exercise Guide included with your Total Gym® to familiarize yourself with the movements. Use the lowest incline level to start with - you can work up to a higher incline level in the weeks and months to come.

For the specific Total Gym® exercises and programs, study and follow the instructions in the *Exercise Guide* included with your product.

# Inspection, Maintenance & Storage

## INSPECT YOUR TOTAL GYM® PRIOR TO EACH USE

Before using your Total Gym® for your workout session, be sure to make the following inspection:

- Make sure the equipment is fully opened and sitting on a solid, level surface with plenty of clearance on all sides. Unit should be used on a mat or on carpeted surfaces only.
- Make sure all the Hitch Pins are securely in place and locked into position.
- Check that the Pulley is attached securely to the loop on the top underside of the glideboard.
- Check that the Cables are traveling correctly in the groove of each pulley.
- Make sure the Cable is securely fastened to each Handle.
- Check that the Multi Function Attachment or other accessories are installed correctly when in use.
- Make sure the Glideboard is gliding smoothly along the frame.

## ROUTINE MAINTENANCE

- Wipe down your Total Gym® on a regular basis using a clean cloth and alcohol or alcohol-based products like Windex® or 409°. Do not leave towels or workout clothing laying or hanging on the equipment.
- Periodically check the following parts for signs of fraying or other wear: the cable, pulleys, wheels, glideboard, accessories and frame. If the cable, pulleys, frame or wheels need replaced - do not use your unit, wait until the part is replaced. If any other part than the ones listed above needs to be replaced, do not use that part until it is replaced.
- Never use a lubricant such as WD-40® or ArmorAll® to lubricate or clean the unit. Use only 3-in-1® oil or machine oil to lubricate the axles of the wheel or pulley, not the roller surface.

## TO STORE YOUR TOTAL GYM®

Follow these easy steps to store your exerciser properly:

1. First, remove all accessories and attachments including the Flip Chart accessory.
2. Remove Safety Hitch Pin and Safety Pin from Vertical Column.
3. Be sure the Cable Pulley is attached to the underside of the glideboard for folding.
4. Position one hand on either side of rail to hold it up before releasing the Height Adjustment Quick Release Pin. Pull pin out and slowly lower the rails to the ground until they rest on the back crossbar.
5. **A.** Release Spring Loaded Pin (on left side rail) as shown.

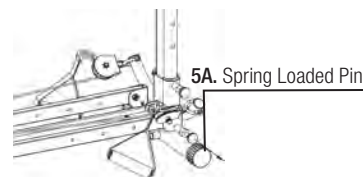

- B.** Fold Vertical Column down towards the center of the unit.
- C.** Then insert Safety Hitch Pin at bottom of vertical column.

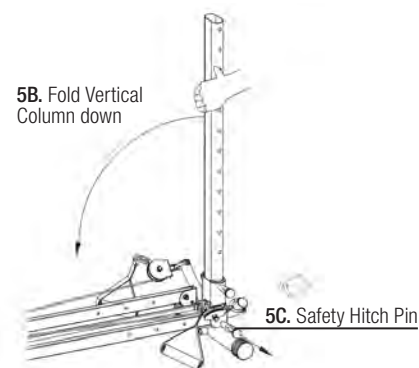

6. Slide the Glideboard towards the bottom of unit as shown.

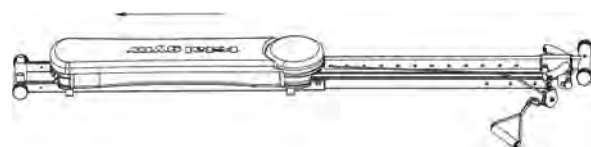

7. **A.** With caution, to avoid pinched fingers or hands, grab the top of the Glideboard and slowly pull the unit up allowing the rollers to bring the back of the unit towards the center. Keep approximately 12" apart.

- B.** Continue to fold the exerciser together until it is completely folded and roll the exerciser into a closet for storage. To store under a bed, simply lower the exerciser to the floor and roll under the bed.

### WARNING LABEL 4

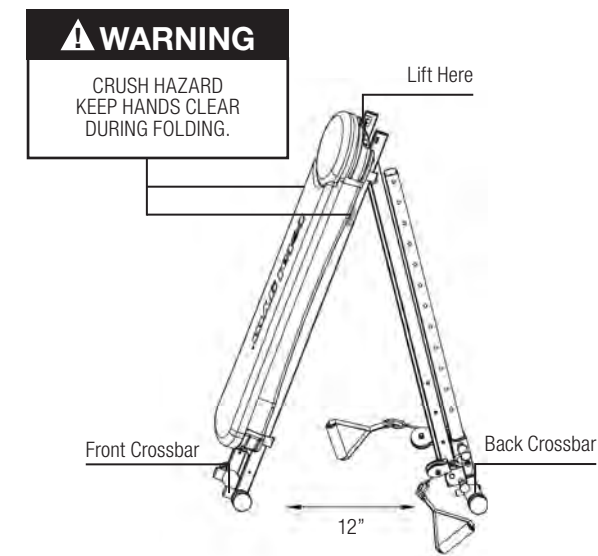

**NOTE:** Do not store unit in upright position when folded.

## TO REMOVE THE GLIDEBOARD

You can also remove the Glideboard if you need to fit the exerciser under a narrow space (between 6" and 8").

**IMPORTANT:** The Glideboard weighs approximately 20 lbs. Use caution when lifting it off of the exerciser. Lifting incorrectly may result in user injury.

1. With exerciser laying flat on the floor, disconnect the pulley from the hook on the underside of the glideboard.
2. Next, tilt up the glideboard and slide it off the frame of the exerciser. When the bench is completely off the exerciser, set it aside.

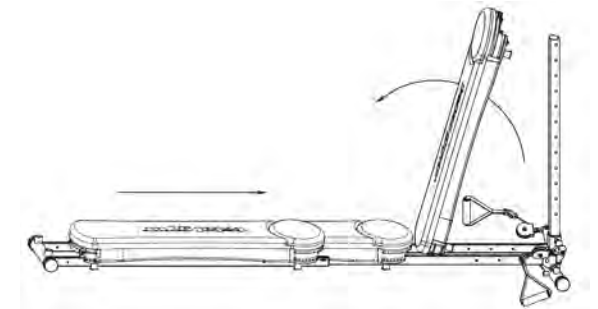

3. Next, pull the Spring Loaded Pin to release the Rail and fold the exerciser together as shown in Figure 7B. Be sure you release the Spring Loaded Pin before folding.

## TO ATTACH THE GLIDEBOARD TO GYM WHEN SETUP AND READY FOR USE

1. Remove Flip Chart from top of vertical column.
2. Raise rails to the highest level on the vertical column and insert safety pin.
3. Carefully pickup the glideboard with both hands, one on each side, making sure the hook on the underside of the glideboard is at the top closest to the vertical column.
4. Line up the glideboard with the lower rails on your gym and gently lower the glideboard down the rails until it rests against the rubber stops.
5. Connect pulley to top underside of the glideboard by taking the pulley and sliding it onto the hook that is on the underside of the glideboard.
6. Insert Flip Chart on the top of vertical column.

# Total Gym® 1600 Parts Visual Overview

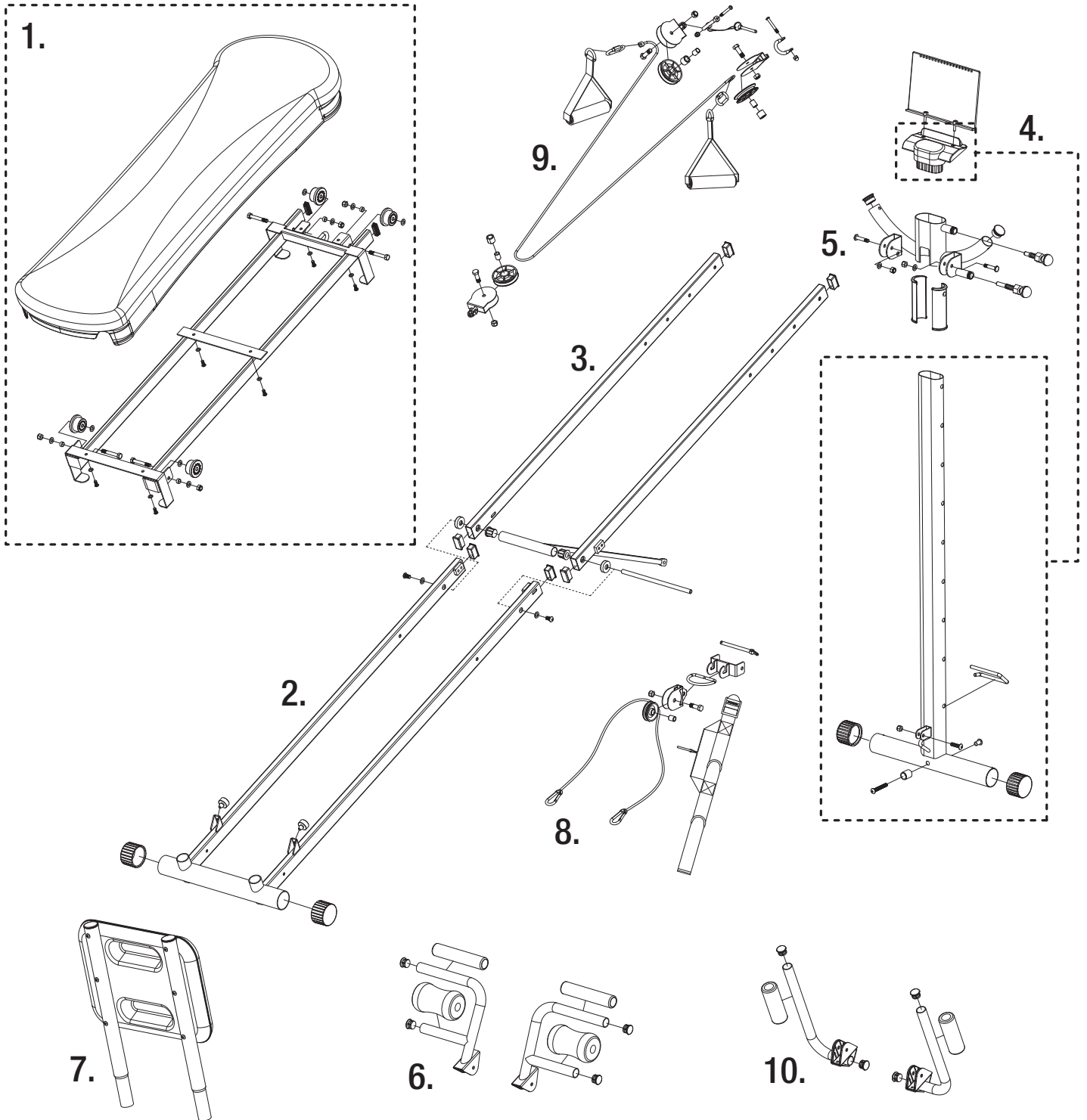

# Total Gym® 1600 Parts List

ITEM #	PART#	DESCRIPTION	QTY	ITEM #	PART#	DESCRIPTION	QTY
<b>1</b>	<b>R1010</b>	<b>Glideboard Assembly</b>	<b>1</b>	<b>5</b>	<b>R1014</b>	<b>Slide Pivot Assembly</b>	<b>1</b>
	R1010-11	Roller Spacer	4		R1014-2	End Cap	2
	R1010-12	8 x 55 Hex Bolt	2		R1014-3	Adjustment Pin	1
	R1010-13	Roller	4		R1014-5	Stopper Pin	1
	R1010-14	8 mm Flat Washer	4	<b>6</b>	<b>R1015</b>	<b>Multi Function Attachment</b>	<b>1</b>
	R1010-15	m8 Mylon Nut	2		R1015-1	Right-side Bar	1
	R1010-16	Rectangle End Cap	2		R1015-2	Left-side Bar	1
<b>2</b>	<b>R1011</b>	<b>Lower Rail Assembly</b>	<b>1</b>	<b>7</b>	<b>R1016</b>	<b>Squat Stand</b>	<b>1</b>
	R1011-2	Bumper Pad	2	<b>8</b>	<b>R1017</b>	<b>Leg Pulley System</b>	<b>1</b>
	R1011-3	End Cap	2		R1017-1	U Bracket	1
	R1011-4	Rectangle End Cap	2		R1017-2	Hitch Pin	1
<b>3</b>	<b>R1012</b>	<b>Upper Rail Assembly</b>	<b>1</b>		R1017-3	Foot Strap	1
	R1012-3	Rectangle End Cap	4		R1017-4	D-Ring	1
<b>4</b>	<b>R1013</b>	<b>Height Adjustment Column</b>	<b>1</b>		R1018	Literature Pack	1
	R1013-2	Big End Cap	1	<b>9</b>	<b>R1021</b>	<b>Cable Kit</b>	<b>1</b>
	R1013-3	Tube Roller	2	<b>10</b>	<b>R1022</b>	<b>Dip Bar Set</b>	<b>1</b>



## DEDICATION TO QUALITY

We warrant this product to be free from all defects in material and workmanship when used according to the manufacturer's instructions.

See Limited Warranty Card for details.

### ***Save your sales receipt.***

You may wish to staple into this manual.

*To order optional accessories,  
please go to [TotalGymCatalog.com](http://TotalGymCatalog.com)*