

MODEL | MODÈLE | MODELO

128193-1

COLOR | COULEUR | COLOR

WO

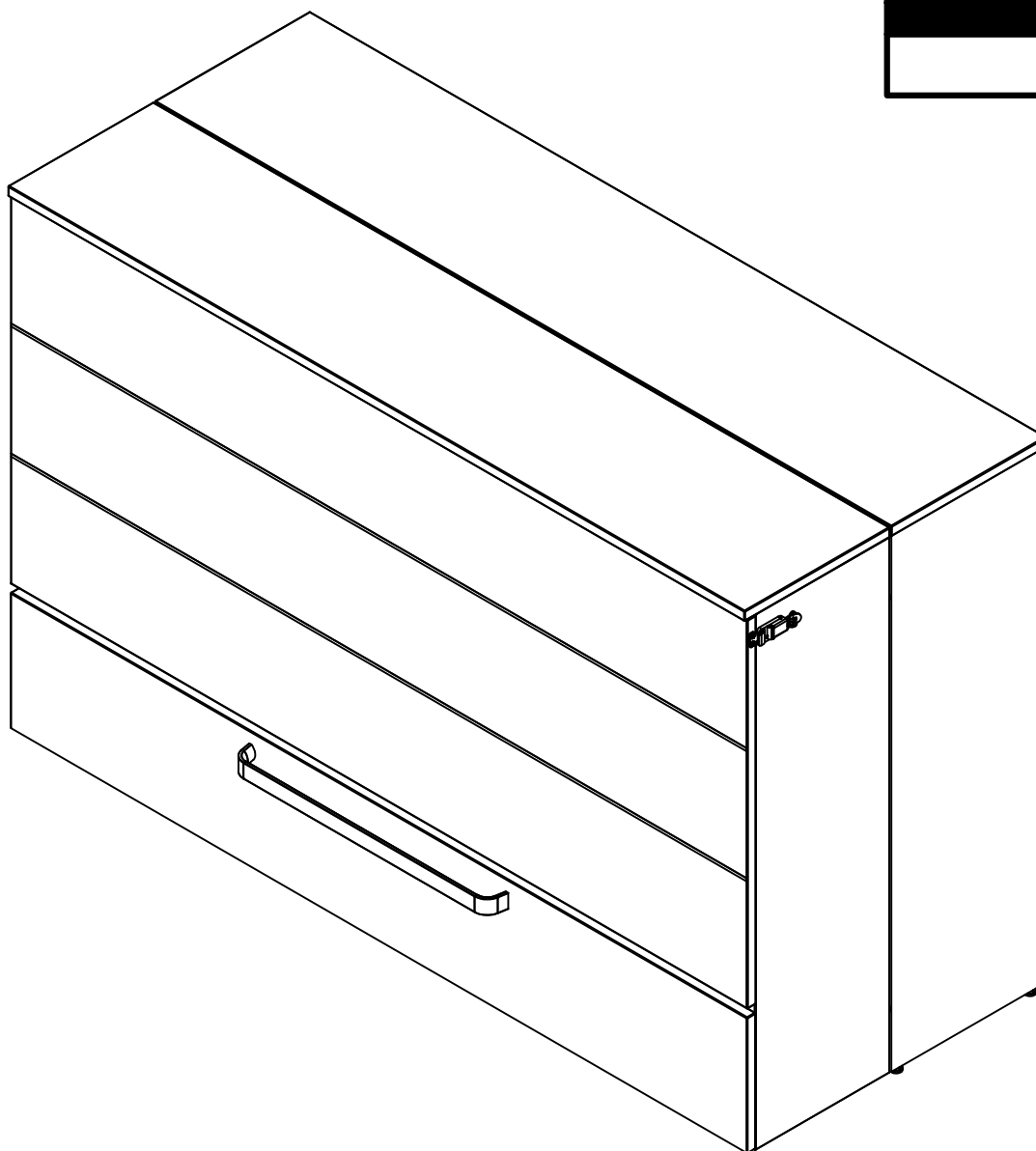

NOTE:

⚠ If there are parts missing from your order or if your product was damaged during shipping, PLEASE CONTACT US DIRECTLY.

NOTE :

⚠ S'il vous manque des pièces ou si votre meuble a été endommagé pendant le transport, VEUILLEZ NOUS CONTACTER DIRECTEMENT.

CONGRATS ON YOUR NEW PURCHASE! FÉLICITATIONS POUR VOTRE NOUVEL ACHAT!

We are thrilled to welcome you to the Bestar family. To ensure you get the most out of your new product, please follow the steps below.

Nous sommes ravis de vous accueillir dans la famille Bestar. Pour vous permettre de profiter au mieux de votre nouveau produit, veuillez suivre les étapes ci-dessous.

1



Activate Your Warranty Activez votre garantie

Register your product for warranty coverage by scanning the QR code or visiting bestar.com/warranty or bestar.ca/warranty. This ensures you receive the best support and service.

Enregistrez votre produit pour être couvert par la garantie en scannant le code QR ou en visitant le bestar.ca/fr/garantie. Vous pourrez ainsi bénéficier d'une assistance et d'un service de qualité.



Scan for Warranty Activation
Balayer pour activer la garantie
https://bestar.zendesk.com/hc/en-us/requests/new?ticket_form_id=23496338049300

2



How Did We Do? Comment avez-vous aimé votre expérience?

We value your feedback. Please take a moment to complete our survey by scanning the QR code. Your input helps us improve our products and services.

Votre avis nous intéresse. Nous vous invitons à prendre un moment pour répondre à notre sondage en scannant le code QR. Vos commentaires nous aident à améliorer nos produits et nos services.



Scan for NPS Survey
Balayer pour répondre au sondage
<https://www.surveymonkey.com/r/WLDTMC3>

3



Assembly Tips Conseils d'assemblage

To make assembly easier, follow our detailed instructions and refer to the video guides available on our website. Scan the QR code for assembly tips and tricks.

Pour faciliter l'assemblage, suivez nos instructions détaillées et consultez les guides vidéo disponibles sur notre site Web. Scannez le code QR pour obtenir des trucs et conseils d'assemblage.



Scan for Assembly Tips
Balayer pour les conseils d'assemblage
<https://bestar.zendesk.com/hc/en-us/articles/31744766678676-Videos>

4



Review & Renew Des avis pour l'avenir

Share your experience with others by leaving a review. As a thank you, we'll plant trees on your behalf, contributing to a greener planet. Scan the QR code to review.

Partagez votre expérience en laissant un avis. Pour vous remercier, nous planterons un arbre en votre nom pour un avenir plus vert. Scannez le code QR pour laisser un avis.



Scan to Leave a Review
Balayer pour laisser un avis
<https://esolutionsfurniture.com/review-and-renew/>

OUR TEAM IS HERE TO HELP. NOTRE ÉQUIPE EST LÀ POUR VOUS AIDER.

If you have any questions or need assistance, our dedicated support team is ready to help. Visit our website for customer support or call our toll-free number.

Si vous avez des questions ou si vous avez besoin d'aide, notre équipe de soutien dévouée est prête à vous aider. Visitez notre site Web pour contacter notre service à la clientèle ou appelez notre numéro de téléphone sans frais.



Visit our website:
Visitez notre site Web :
bestar.com/support
bestar.ca/support
bestar.ca/fr/soutien



Call our toll-free number:
Appelez notre numéro sans frais :
1-800-950-4782

Important Notice / Note importante / Nota importante

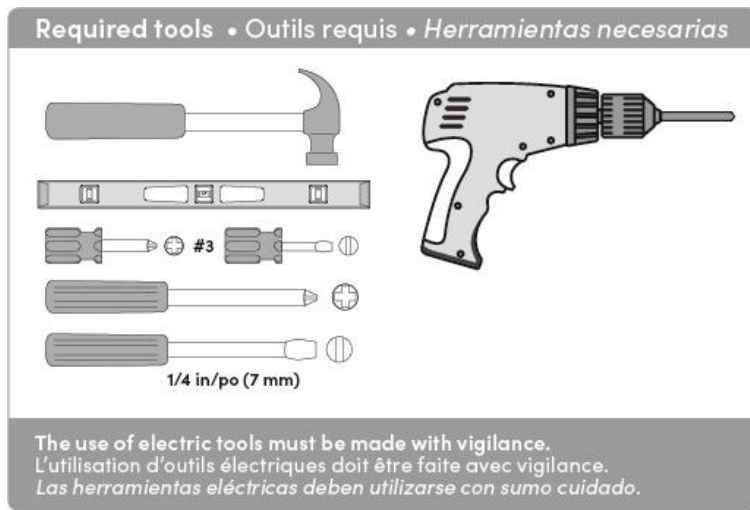
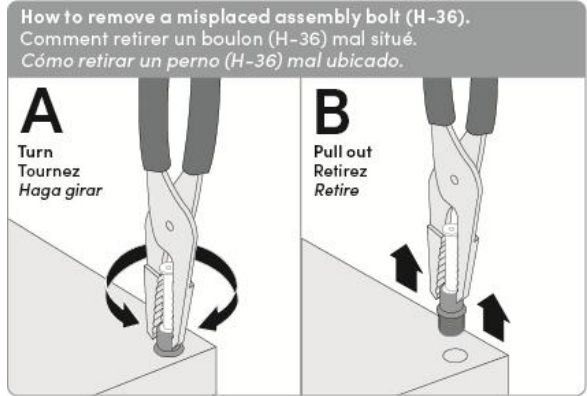
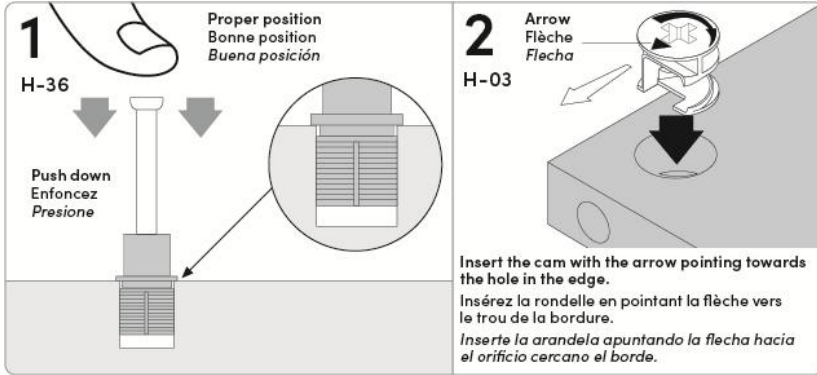

ASSEMBLY GUIDE
GUIDE D'ASSEMBLAGE
INSTRUCCIONES DE ENSAMBLAJE

bestar solutions
ameublement | furniture

MODEL / MODELE / MODELO
COLOR / COULEUR / COLOR
NO

△ NOTE:
If there are parts missing from your order or if your product was damaged during shipping, PLEASE CONTACT US DIRECTLY.

△ NOTE:
Si il vous manque des pièces ou si votre meuble a été endommagé pendant le transport, VEUILLEZ NOUS CONTACTER DIRECTEMENT.

△ NOTE:
En caso de piezas faltantes o si su producto fue dañado durante el envío, POR FAVOR CONTACTENOS DIRECTAMENTE.

KEEP MANUAL FOR FUTURE REFERENCE. | CONSERVEZ LE MANUEL POUR RÉFÉRENCE FUTURE. | GUARDE EL MANUAL PARA REFERENCIA FUTURA.

bestar solutions
ameublement | furniture

To better serve you!
pour mieux vous servir!

Model / Modéle: _____

Production Number
Numéro de production: _____

Customer Service
Service à la clientèle **1-800-950-4782**

Important Notice • Note importante • Nota importante

For future reference and to allow us to serve you better, please complete the self-adhesive sticker and apply it in an accessible space such as under shelf.

Pour que nous puissions mieux vous servir en cas besoin, veuillez compléter l'autocollant et l'apposer dans un endroit facilement accessible tel que dessous d'une tablette.

Para futuras referencias y un mejor servicio, por favor pegue la etiqueta adhesiva en un espacio accesible, Por ejemplo, la parte interior del estante.

128193-1-0071			
Code	Qty-Qté	Code	Qty-Qté
30	1	44	1
31	1	45	2
34	1	60	1
35	1	64	1
40	1	66	1
42	1	70	1

128193-1-1771			
Code	Qty-Qté	Code	Qty-Qté
30	1	42	1
31	1	43	2
32	1	61	1
33	1	64	1
40	1	66	1
41	1	70	1

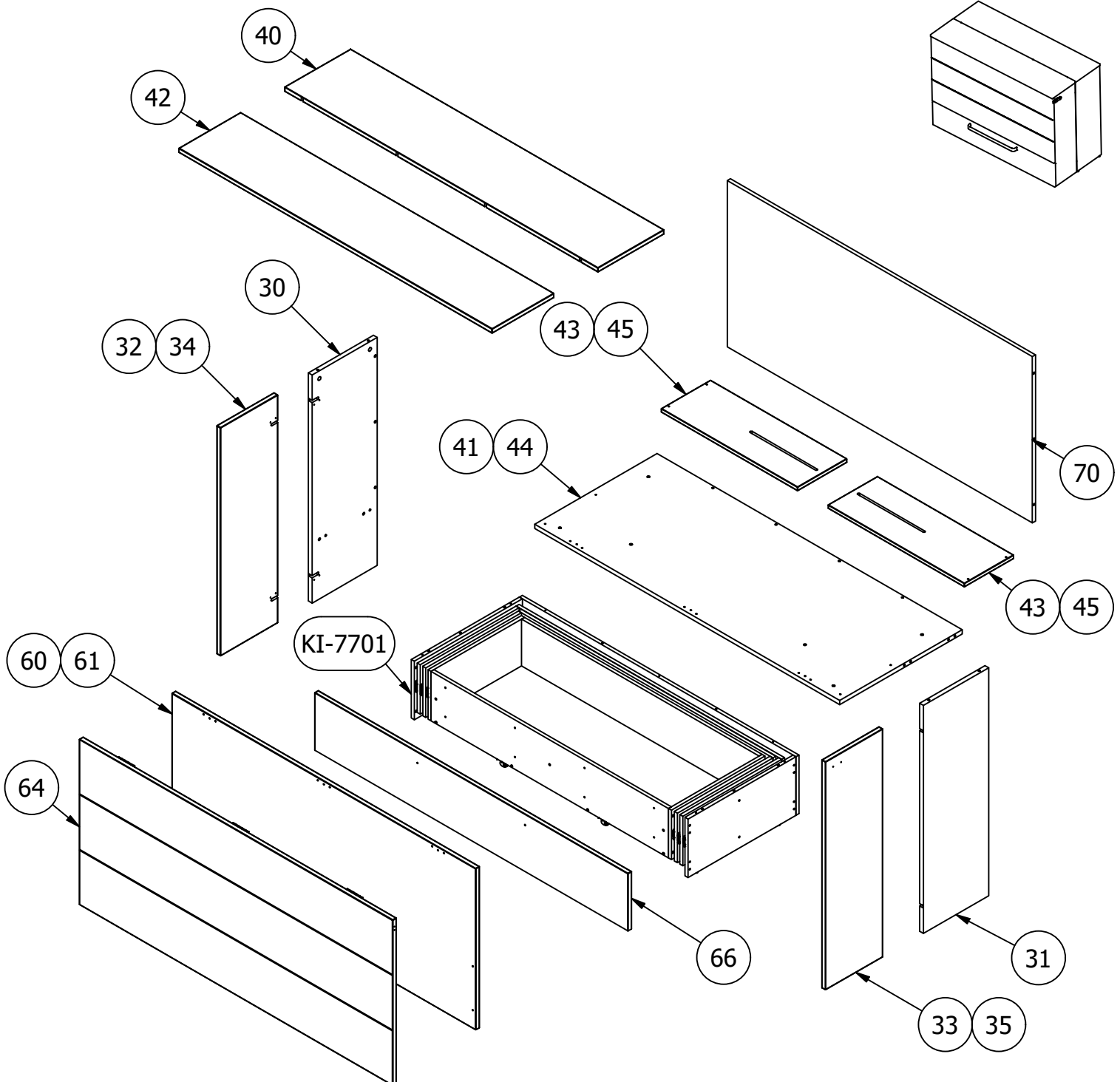

3500-400350  [18]
5/8in/po (16mm)

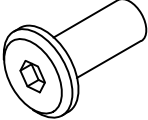
KI-932-H  [2]
3/4in/po (18mm)

VP-221  [32]
5/8 in/po (16mm)

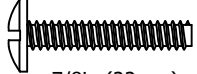
VF-232  [4]
7/8in (22mm)

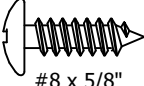
VR-210  [2]
#8 x 5/8"

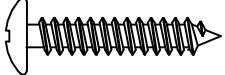
VR-212  [8]
#8 x 1"

VM-601  [2]
3/4in (20mm)

VF-964  [4]
1" (25mm)

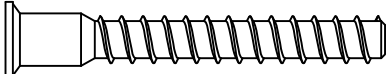
VC-204  [8]
2in (50mm)

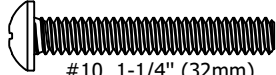
VF-1067  [2]
#10 1-1/4" (32mm)

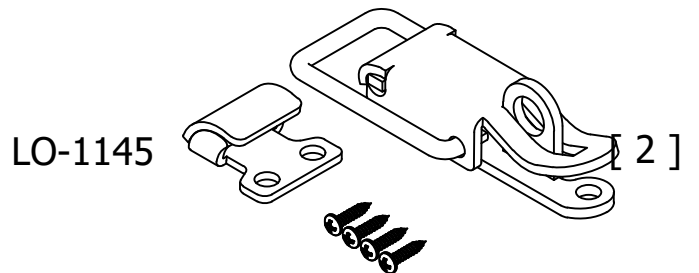
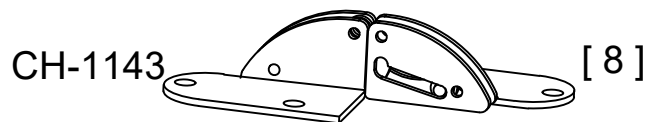
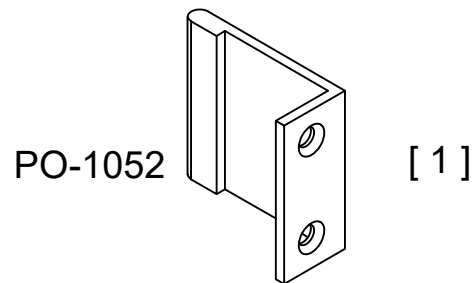
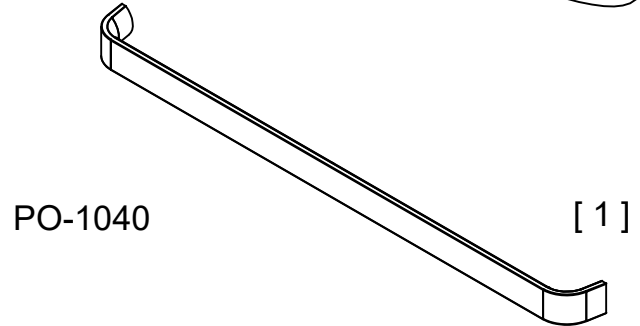
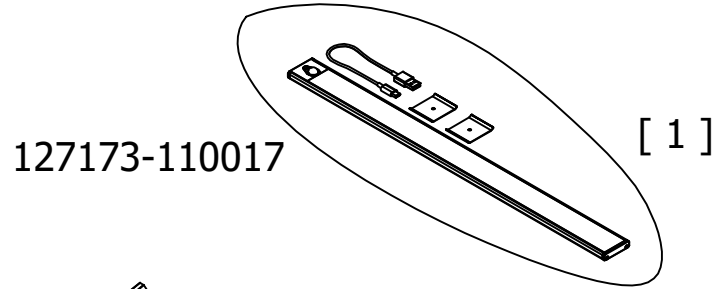
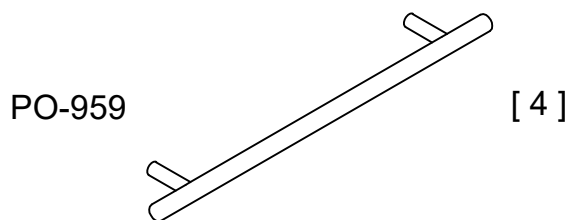
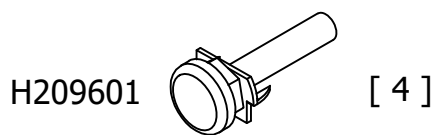
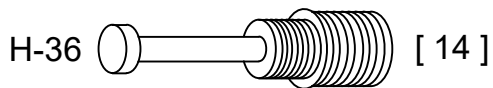
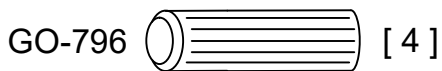
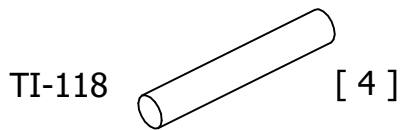
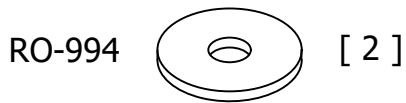
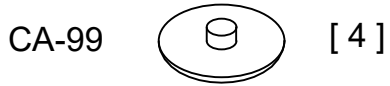
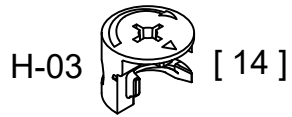

Hardware not to scale.

TIPOVER RESTRAINT HARDWARE

HERRAJES ANTIVUELCO
QUINCAILLERIE ANTI-BASCULEMENT

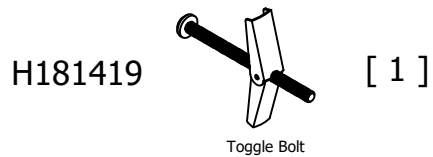
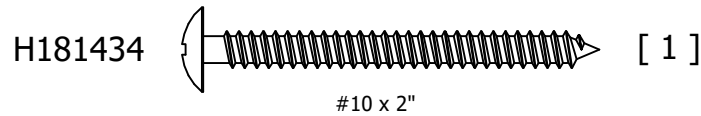
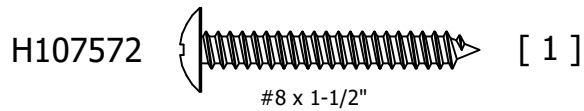
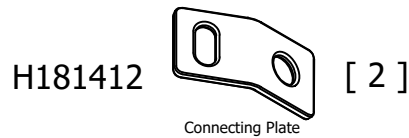
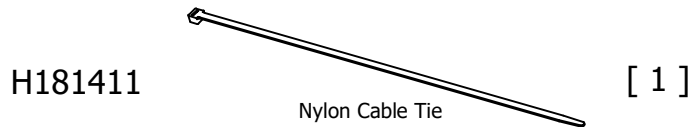

Important Notice / Note importante / Nota importante

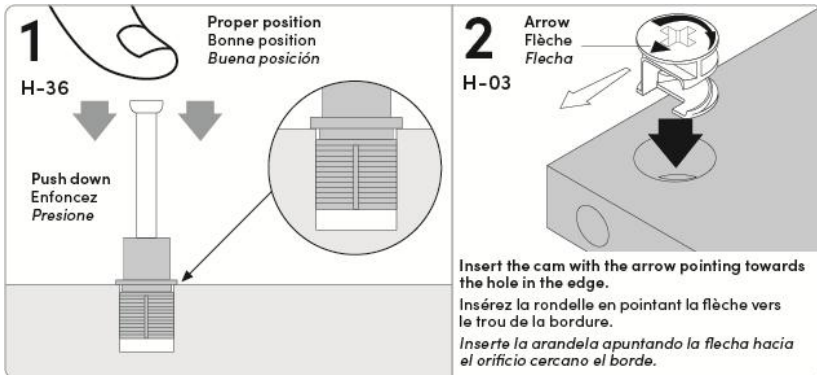

How to remove a misplaced assembly bolt (H-36).
Comment retirer un boulon (H-36) mal situé.
Cómo retirar un perno (H-36) mal ubicado.

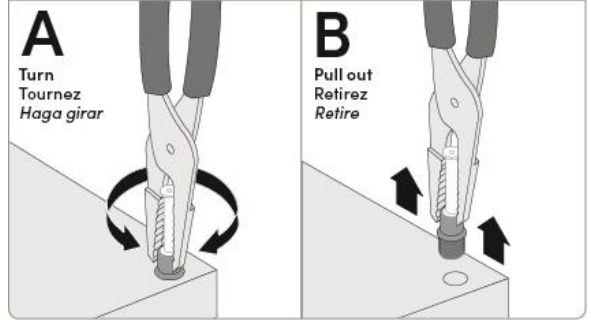

Required tools • Outils requis • Herramientas necesarias

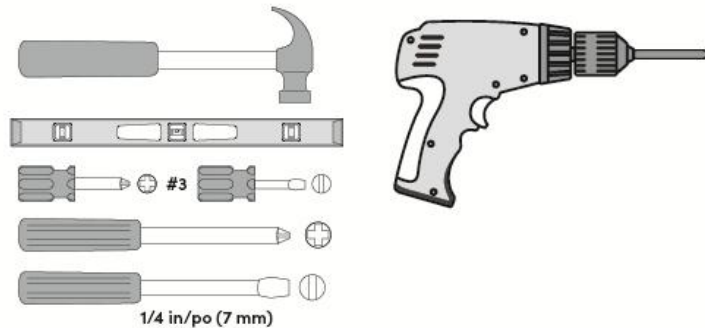

The use of electric tools must be made with vigilance.
L'utilisation d'outils électriques doit être faite avec vigilance.
Las herramientas eléctricas deben utilizarse con sumo cuidado.

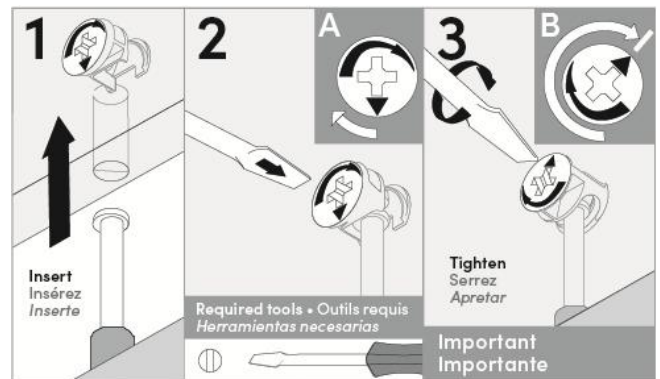

Make sure to properly tighten each cam to ensure furniture solidity.
Otherwise, parts could be damaged or the user could be injured.

Assurez-vous de bien resserrer chaque rondelle pour assurer la solidité du meuble. Dans le cas contraire, des pièces pourraient être endommagées ou l'utilisateur pourrait se blesser.

Asegúrese de bien apretar cada tornillo de araña para garantizar la solidez del mueble. De lo contrario, podría provocarse daño a las piezas o las personas.

ASSEMBLY GUIDE
GUIDE D'ASSEMBLAGE
INSTRUCCIONES DE ENSAMBLAJE

bestar solutions
ameublement | furniture

MODEL / MODÈLE / MODELO
COLOR / COULEUR / COLOR
NO.

△ NOTE:
If there are parts missing from your order or if your product was damaged during shipping, PLEASE CONTACT US DIRECTLY.

△ NOTE:
Si il vous manque des pièces ou si votre meuble a été endommagé pendant le transport, VEUILLEZ NOUS CONTACTER DIRECTEMENT.

△ NOTA:
En caso de piezas faltantes o si su producto fue dañado durante el envío, POR FAVOR CONTACTENOS DIRECTAMENTE.

KEEP MANUAL FOR FUTURE REFERENCE. | CONSERVEZ LE MANUEL POUR RÉFÉRENCE FUTURE. | GUARDE EL MANUAL PARA REFERENCIA FUTURA.



To better serve you!
pour mieux vous servir!

Model / Modéle: _____

Production Number
Numéro de production: _____

Customer Service
Service à la clientèle 1-800-950-4782

Important Notice • Note importante • Nota importante

For future reference and to allow us to serve you better, please complete the self-adhesive sticker and apply it in an accessible space such as under shelf.

Pour que nous puissions mieux vous servir en cas besoin, veuillez compléter l'autocollant et l'apposer dans un endroit facilement accessible tel que dessous d'une tablette.

Para futuras referencias y un mejor servicio, por favor pegue la etiqueta adhesiva en un espacio accesible, Por ejemplo, la parte interior del estante.

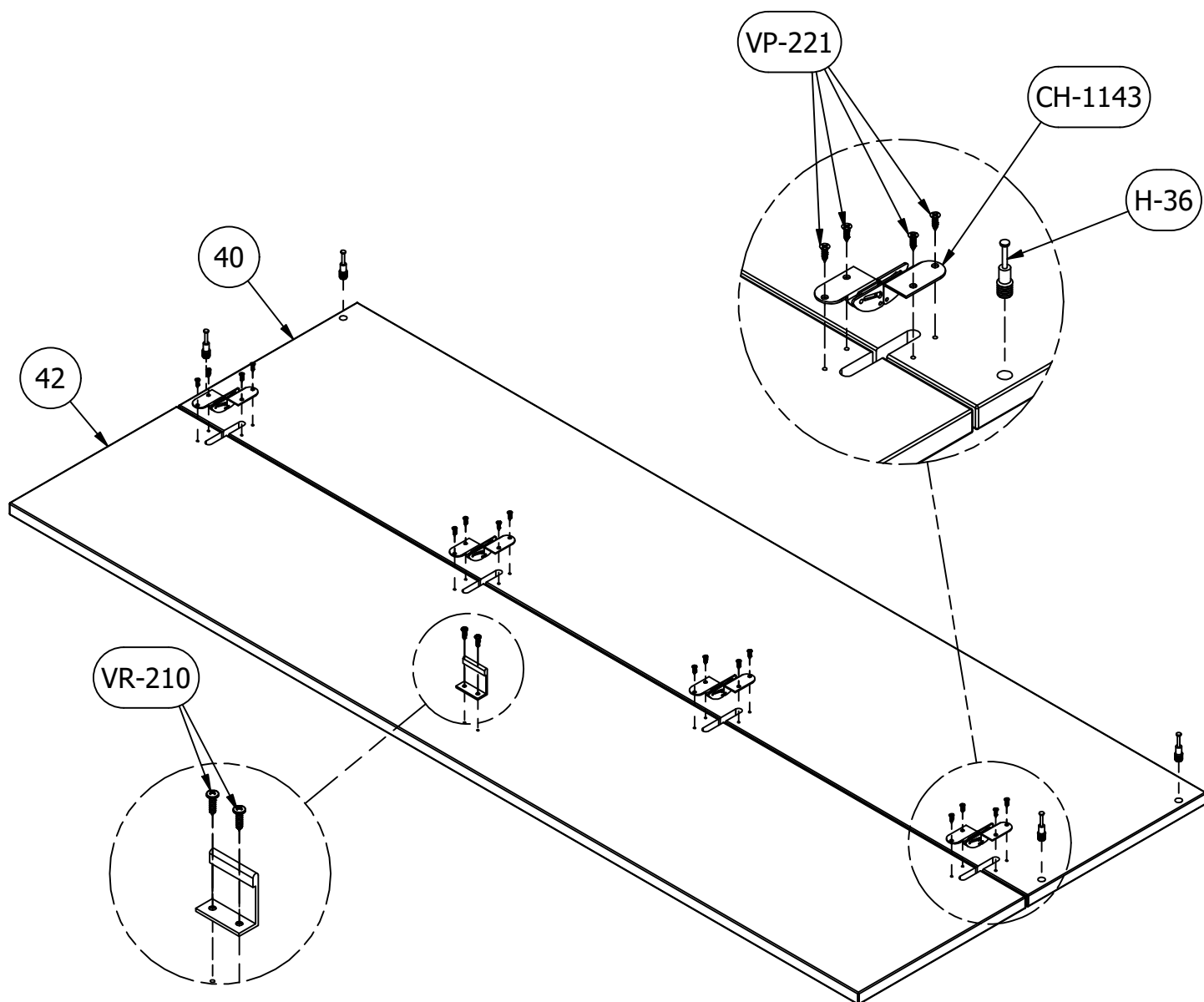
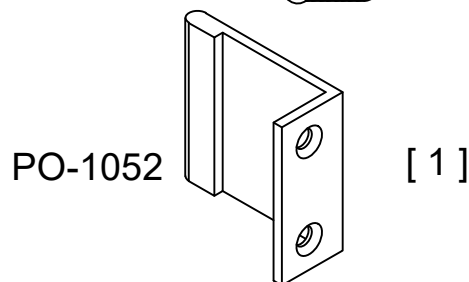
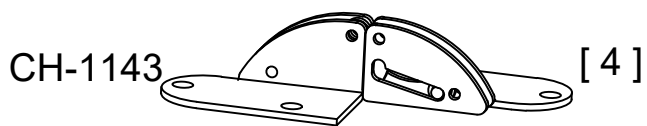
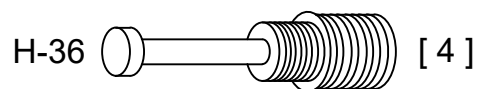
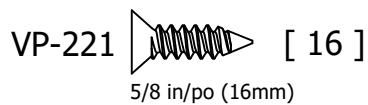
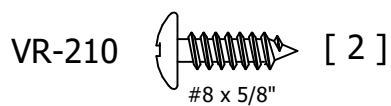

VP-221  [8]
5/8 in/po (16mm)

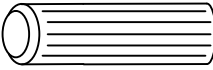
GO-796  [2]

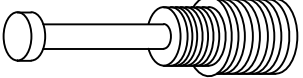
H-36  [5]

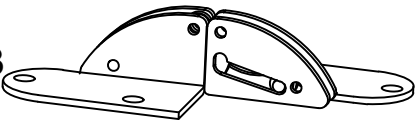
CH-1143  [2]

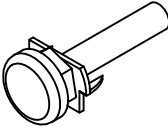
H209601  [2]

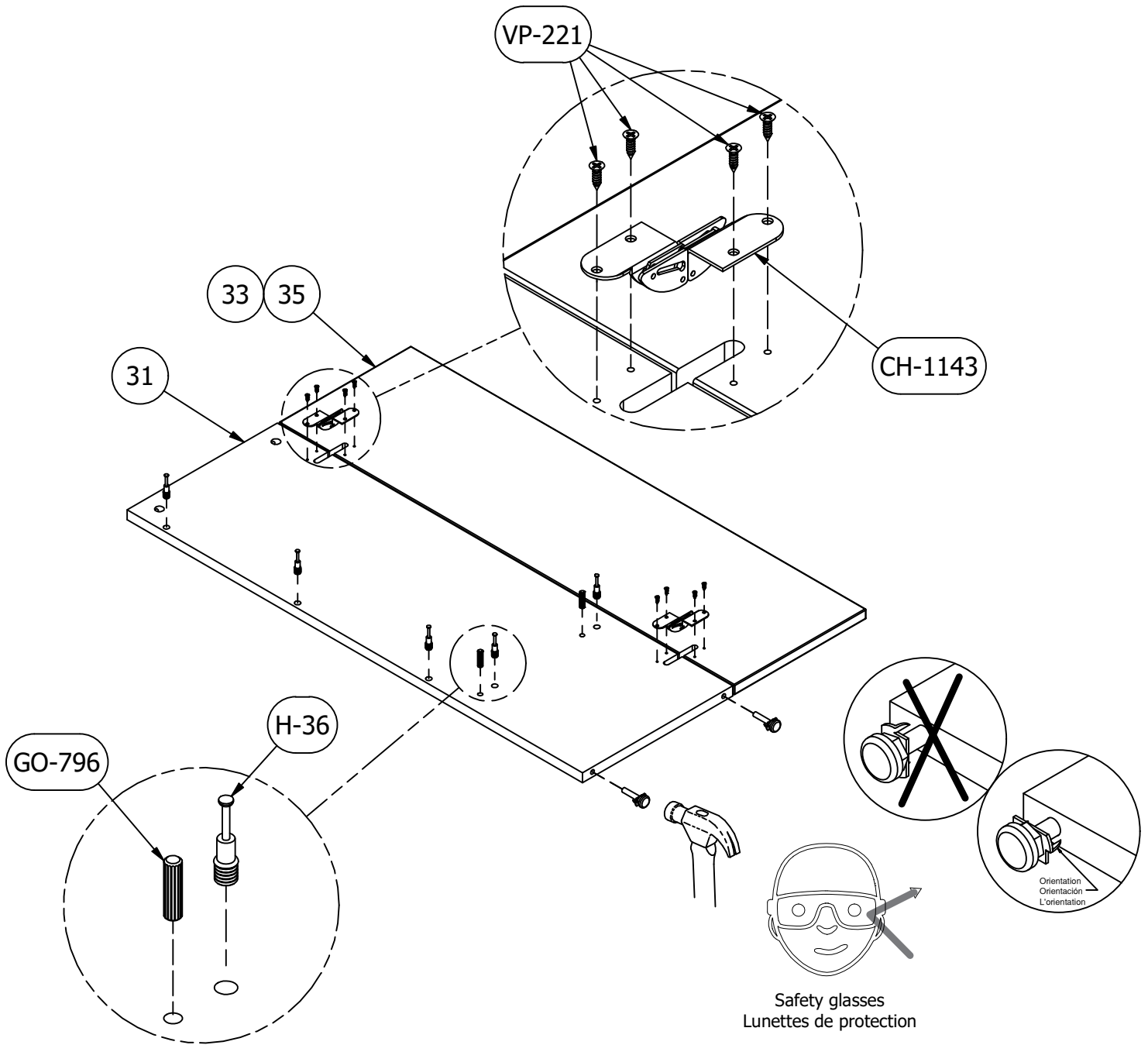

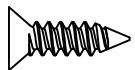
VP-221  [8]
5/8 in/po (16mm)

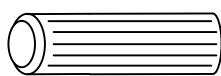
GO-796  [2]

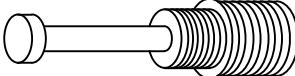
H-36  [5]

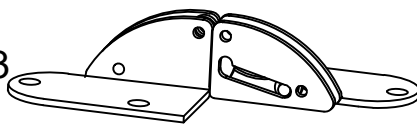
CH-1143  [2]

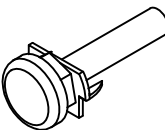
H209601  [2]

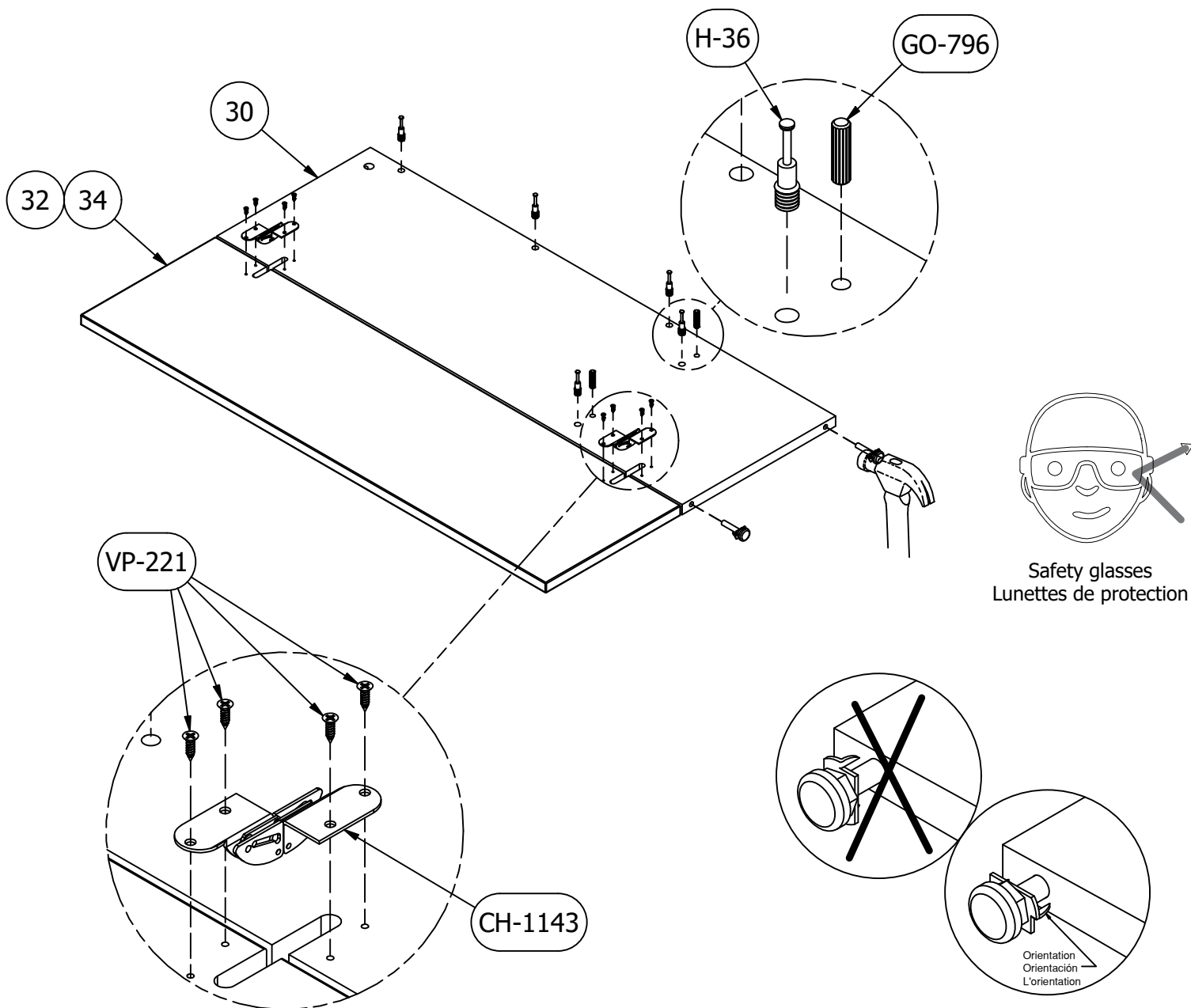

KI-932-H

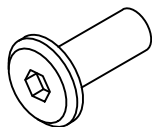

[2]

3/4in/po (18mm)

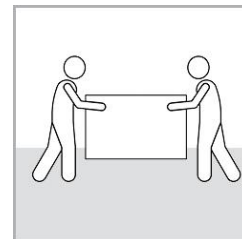

Team Lift
Effort d'équipe

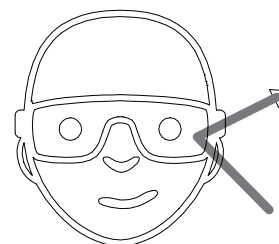
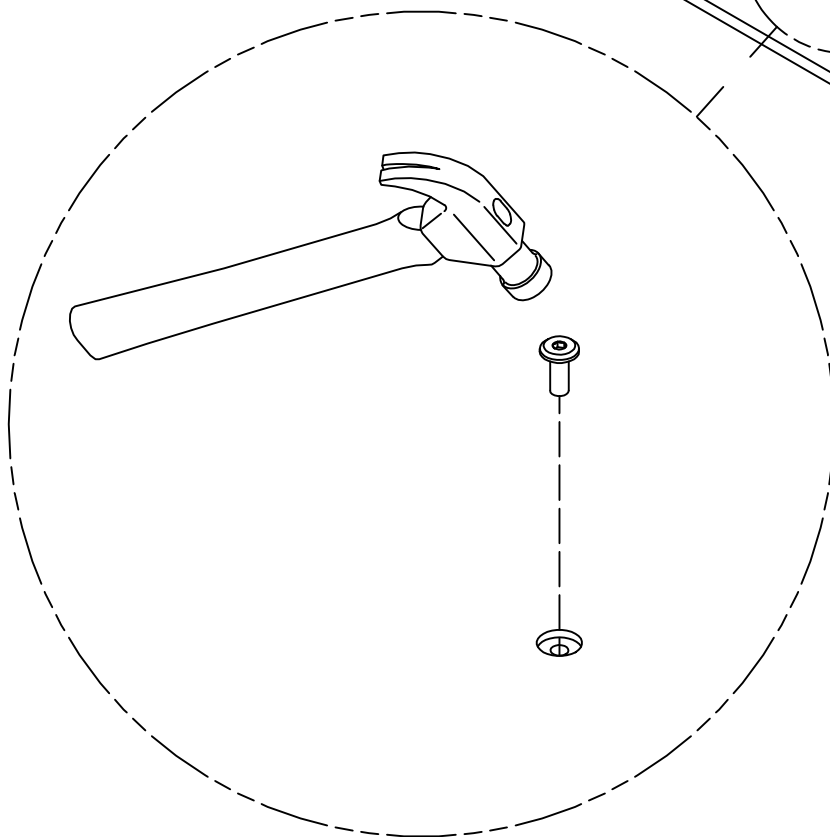
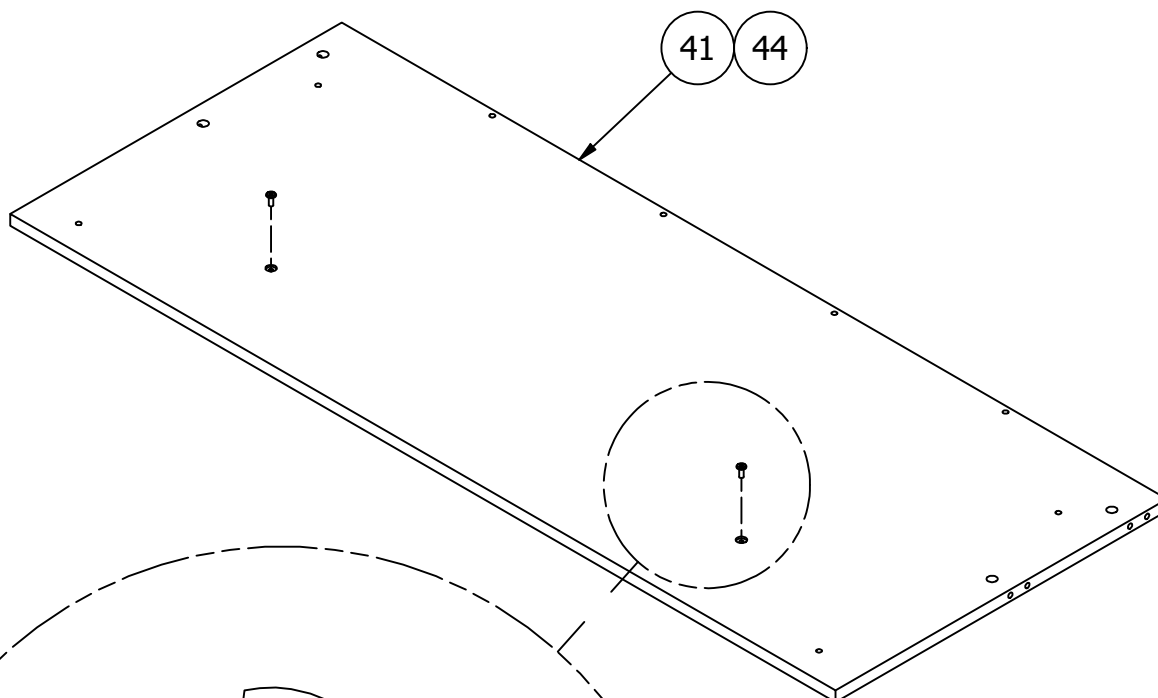

Safety glasses
Lunettes de protection

VF-232 [4]
7/8in (22mm)

PO-959

[2]

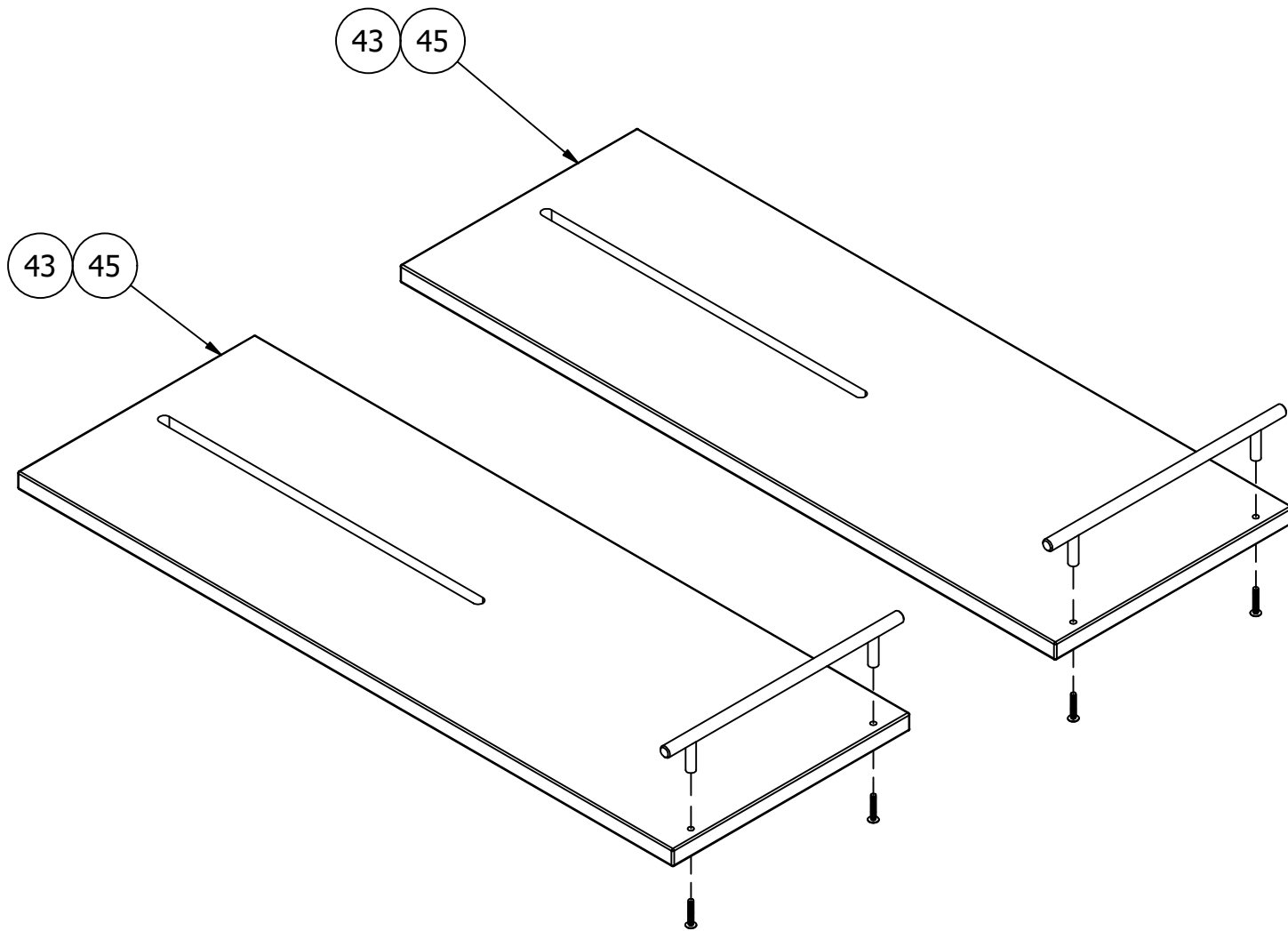
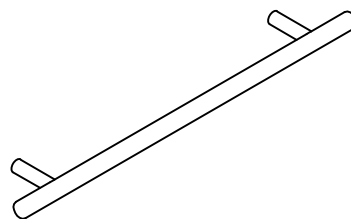

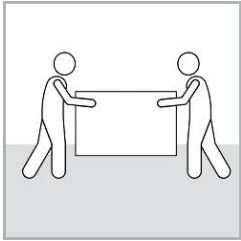

Team Lift
Effort d'équipe

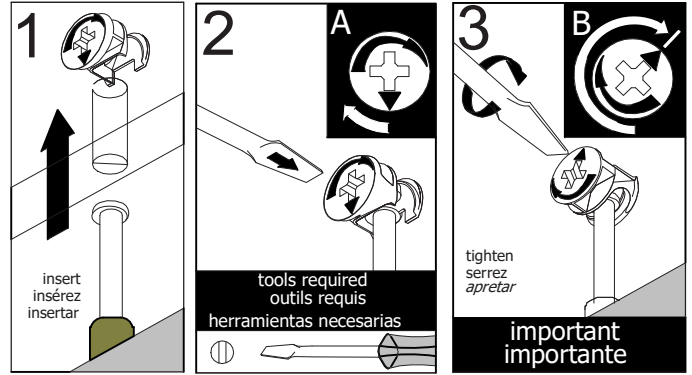
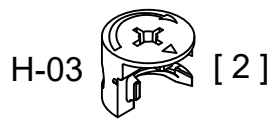

Orientation
Orientación
L'orientation

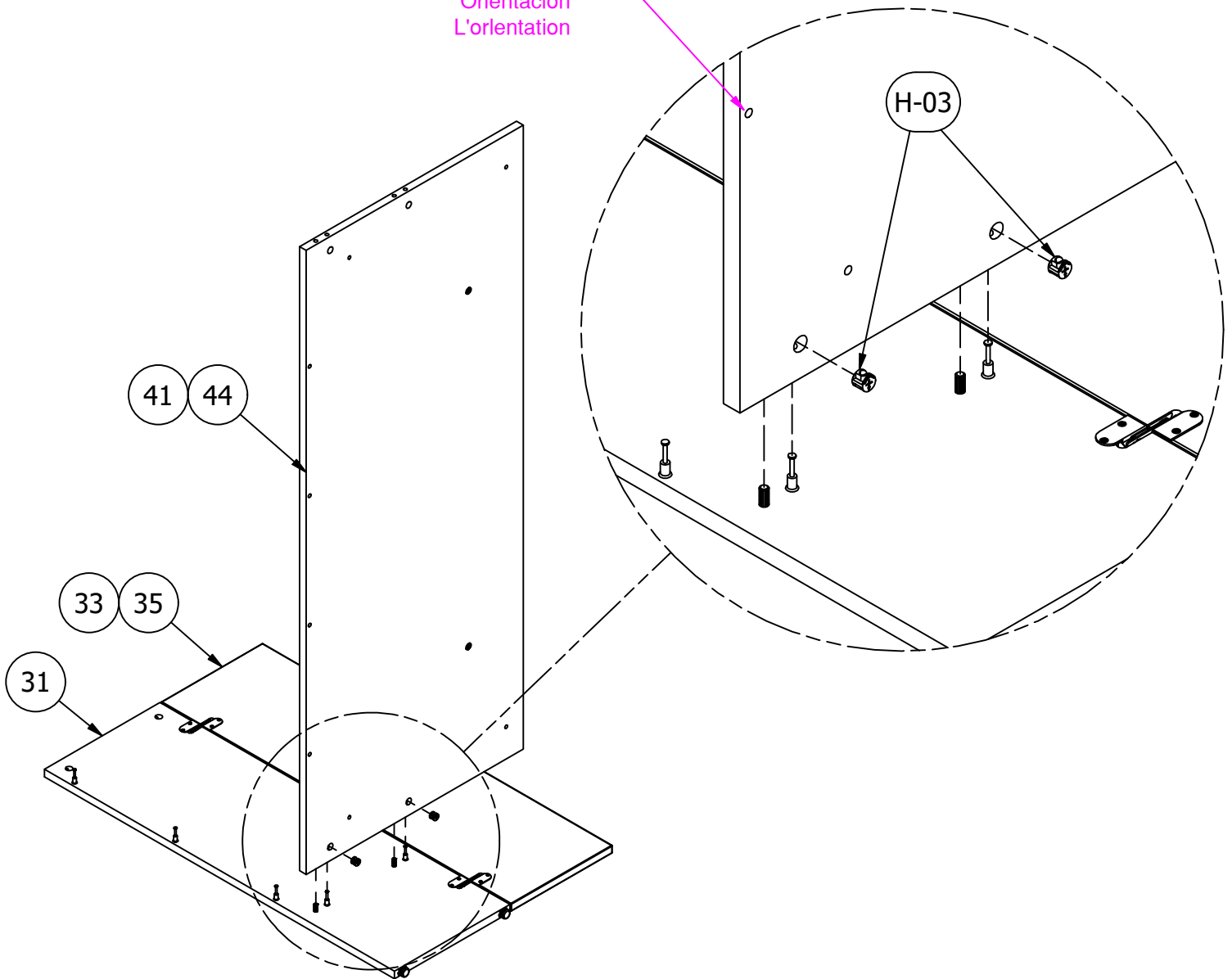

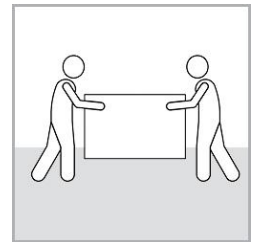
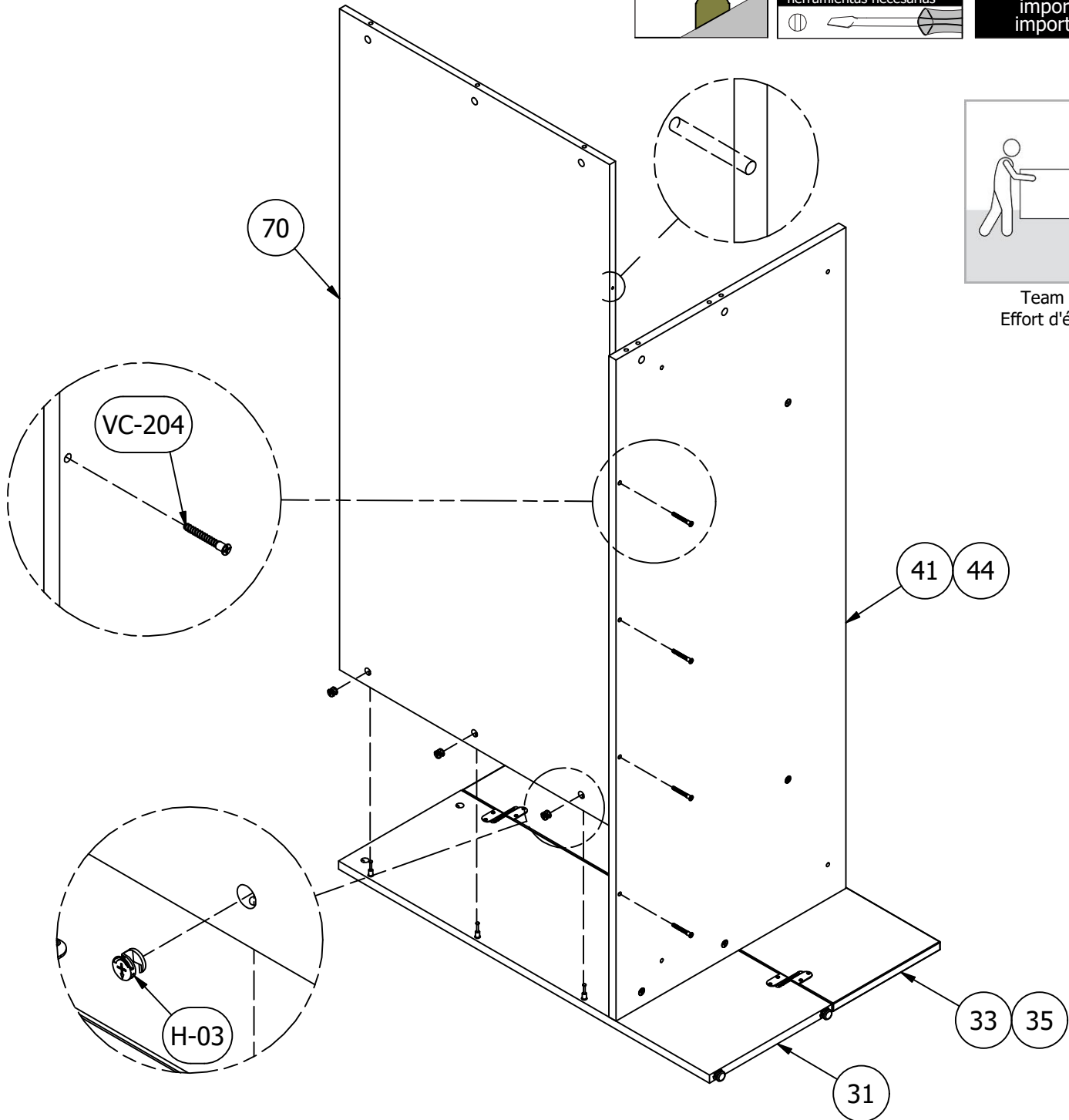
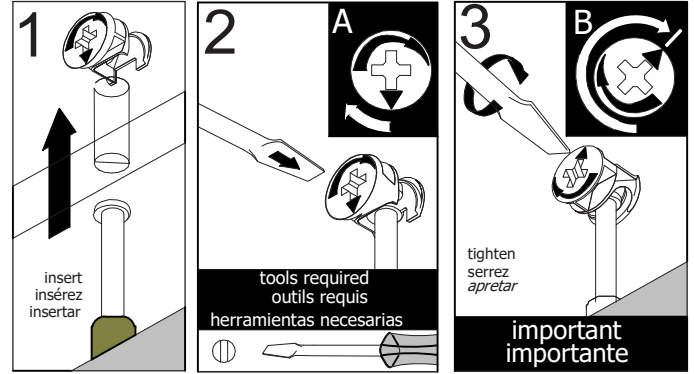
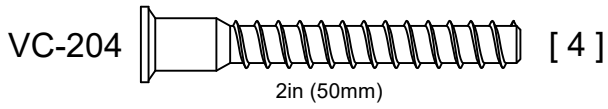

Team Lift
Effort d'équipe

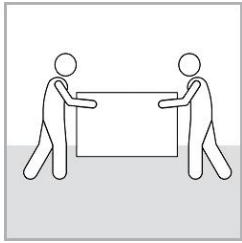

Team Lift
Effort d'équipe

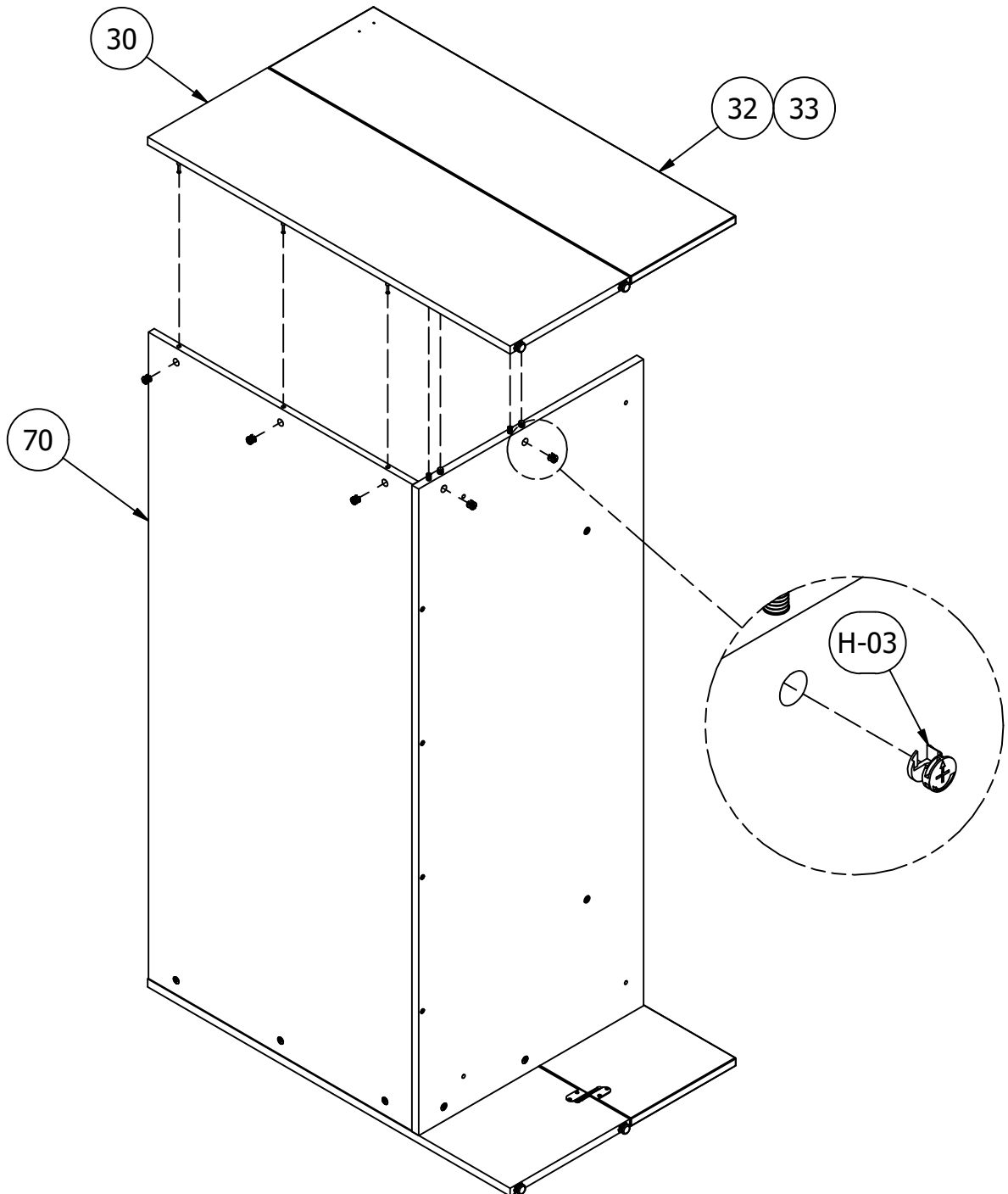
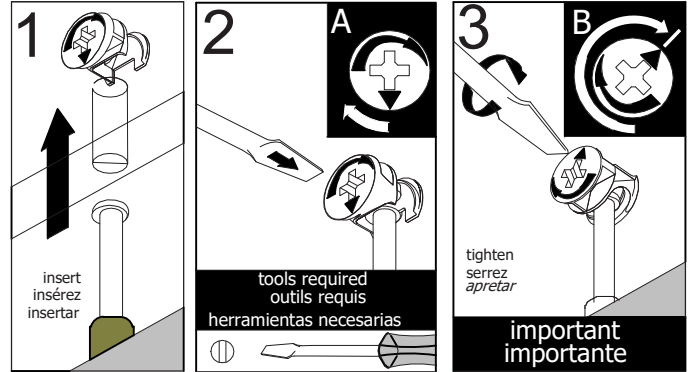
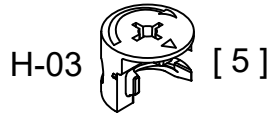

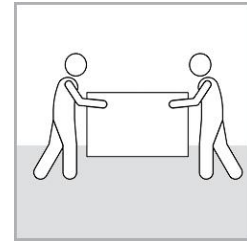
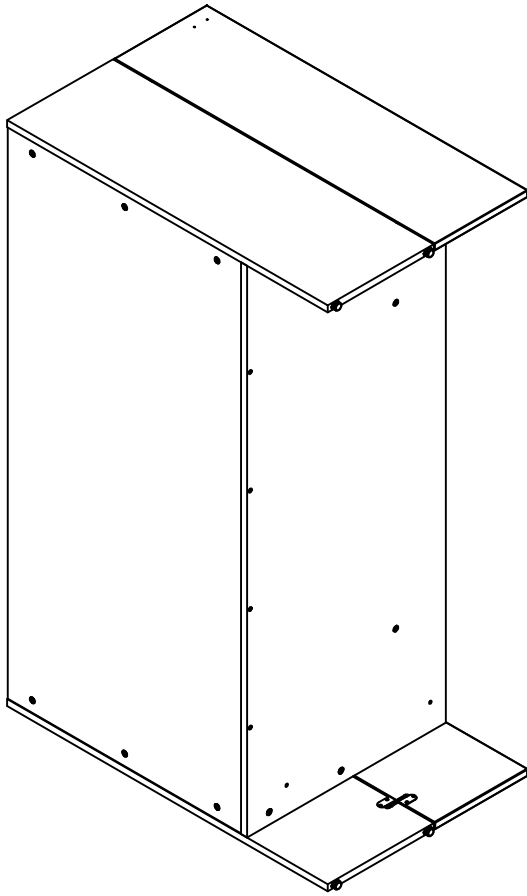

Team Lift
Effort d'équipe

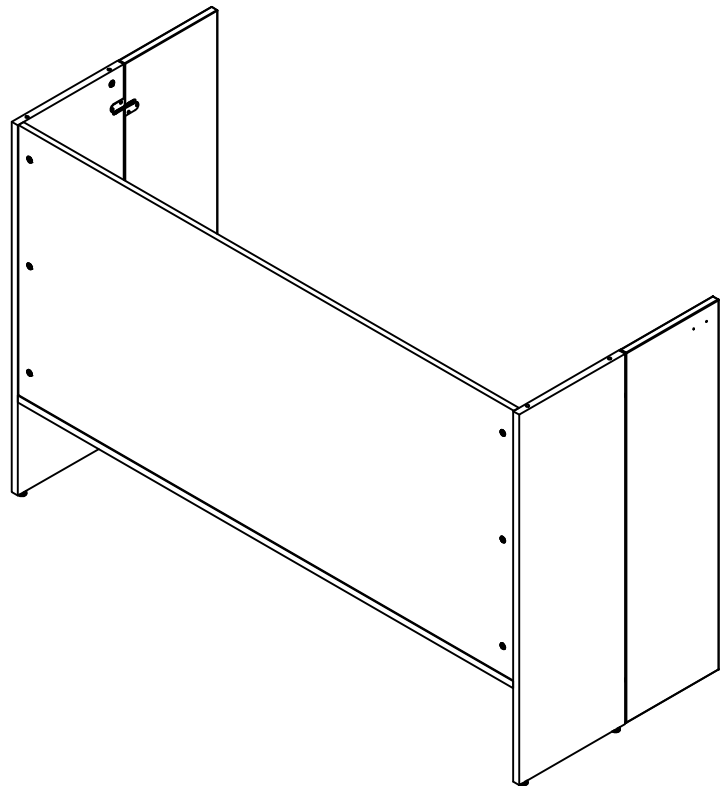

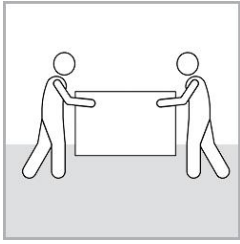

Team Lift
Effort d'équipe

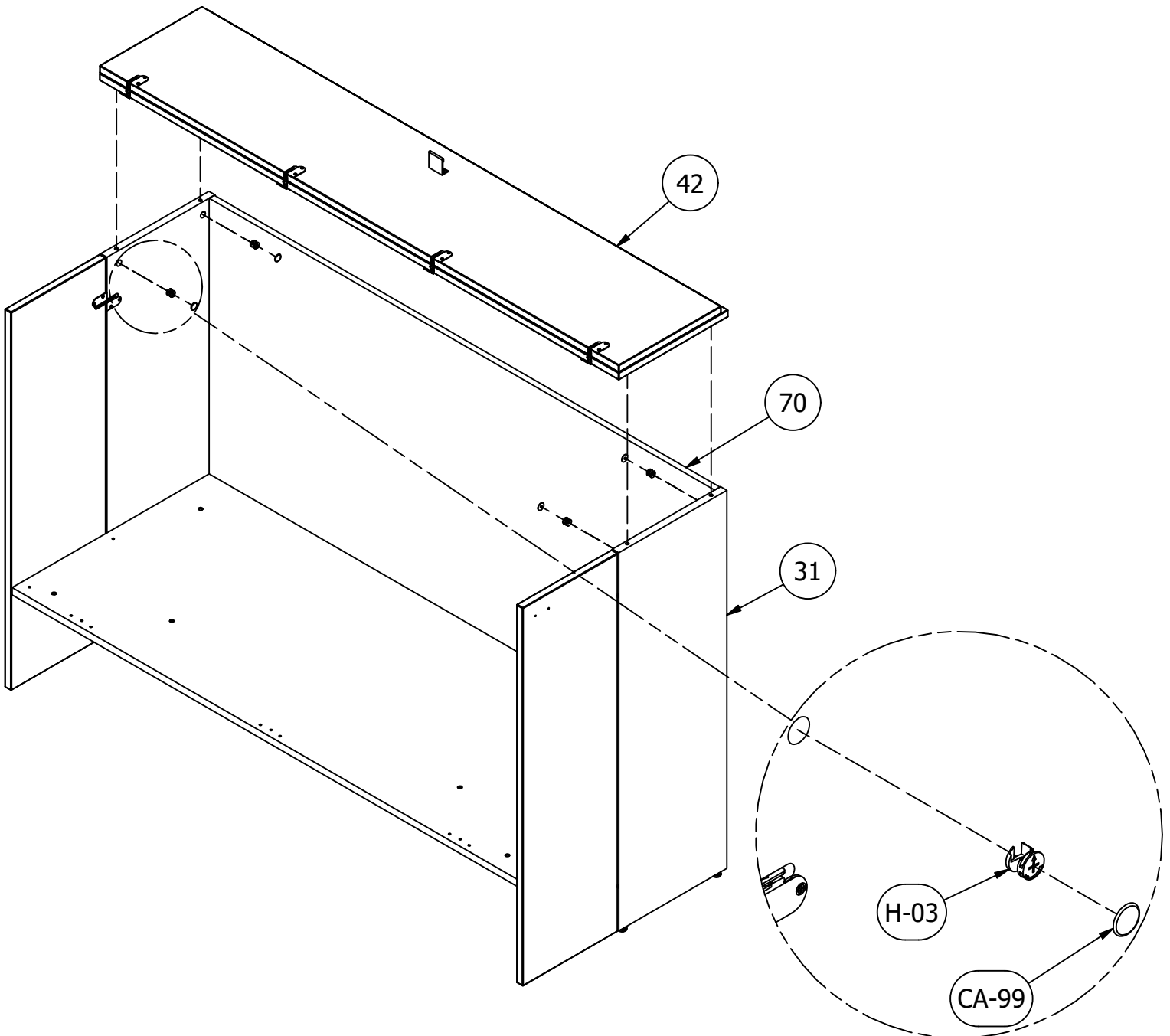
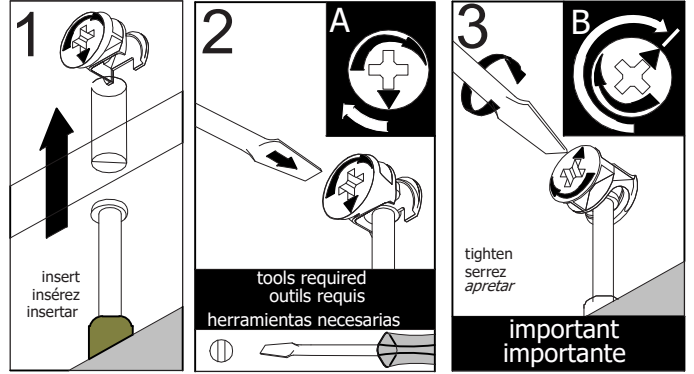
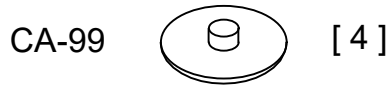
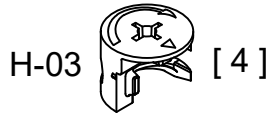

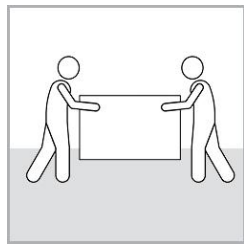

Team Lift
Effort d'équipe

VC-204 [4]
2in (50mm)

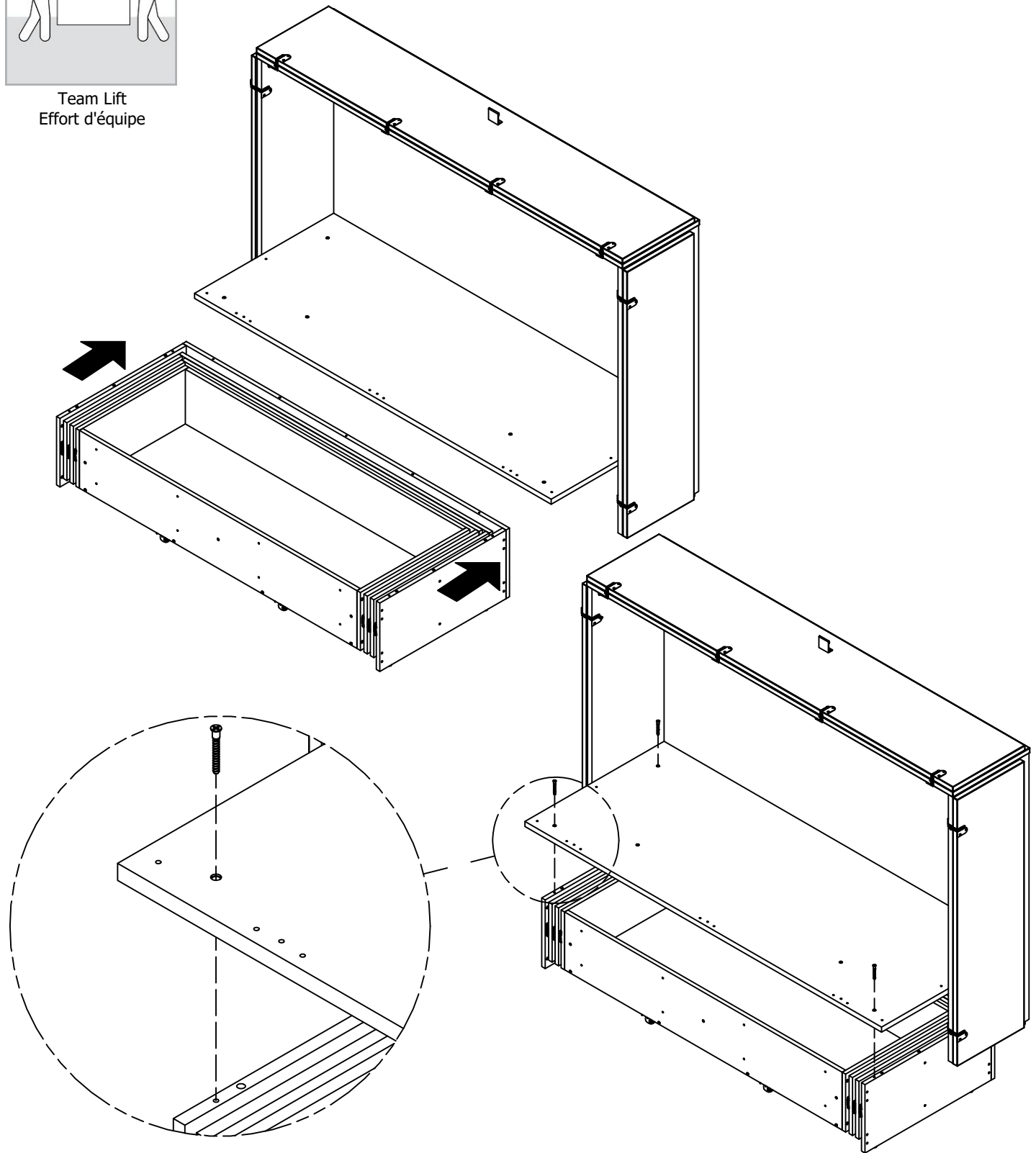

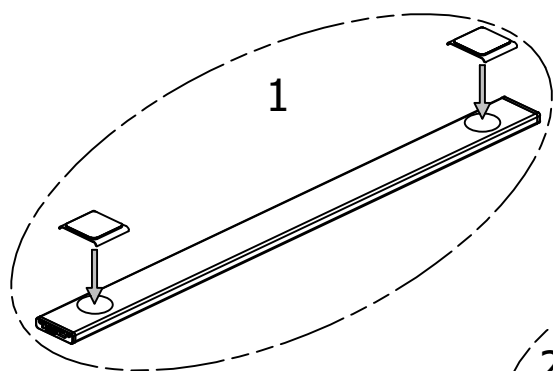

127173-110017

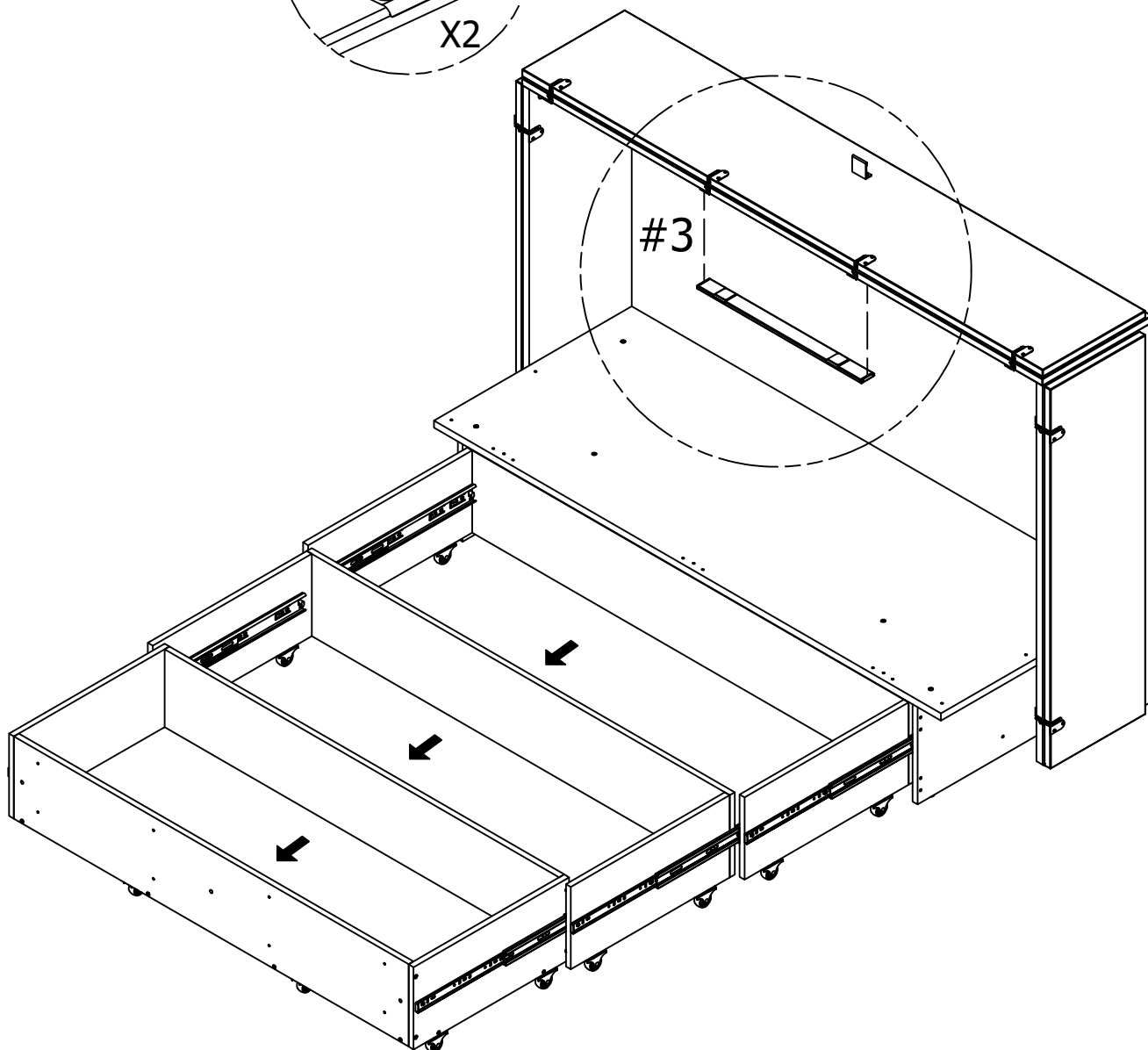
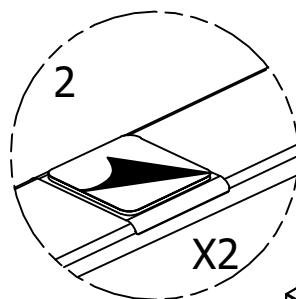
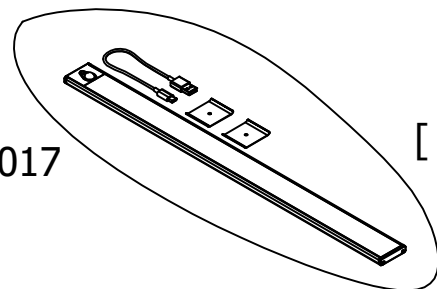

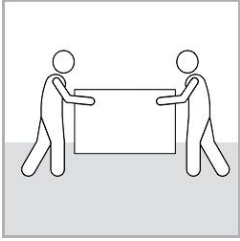

Team Lift
Effort d'équipe

LO-1145

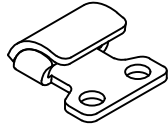

[2] TI-118

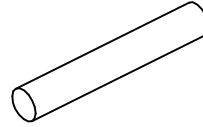



[4] 3500-400350

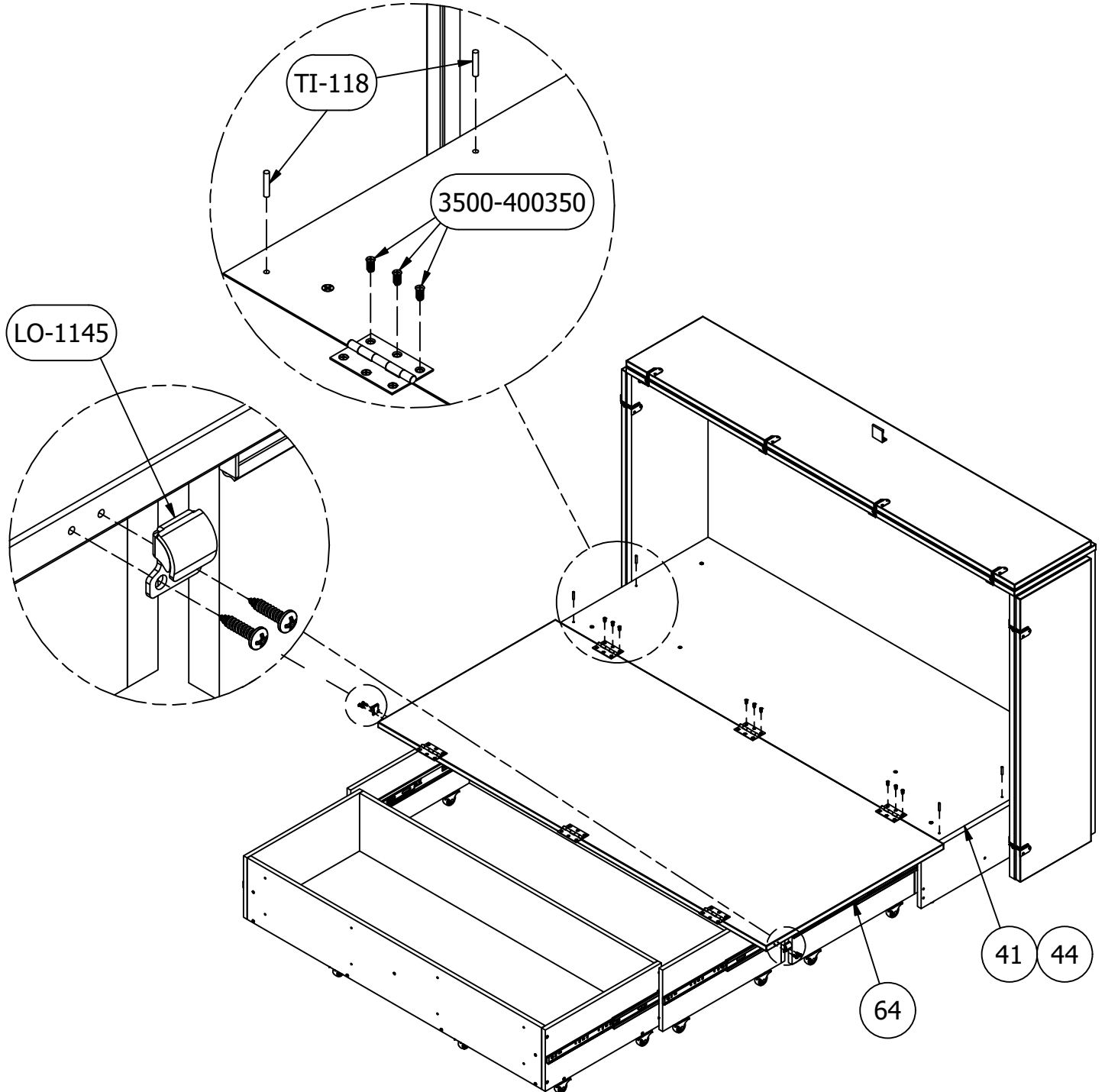

[9]

5/8in/po (16mm)

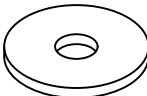

VF-1067  [2] RO-994  [2]
#10 1-1/4" (32mm)

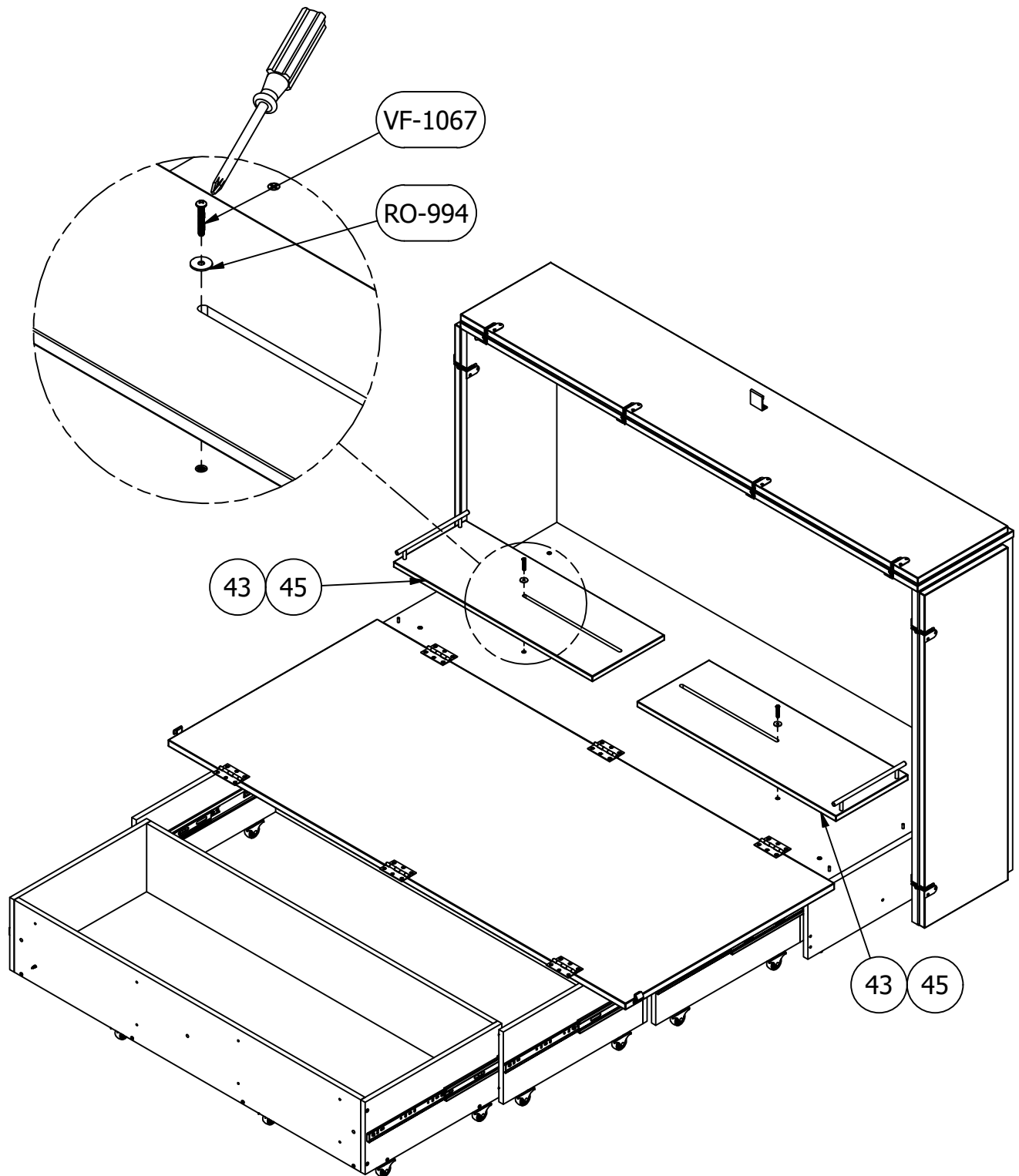

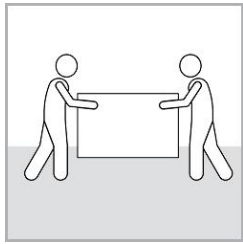

Team Lift
Effort d'équipe

3500-400350  [9]
5/8in/po (16mm)

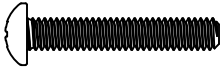
VF-964  [4]
1" (25mm)

PO-959

[2]

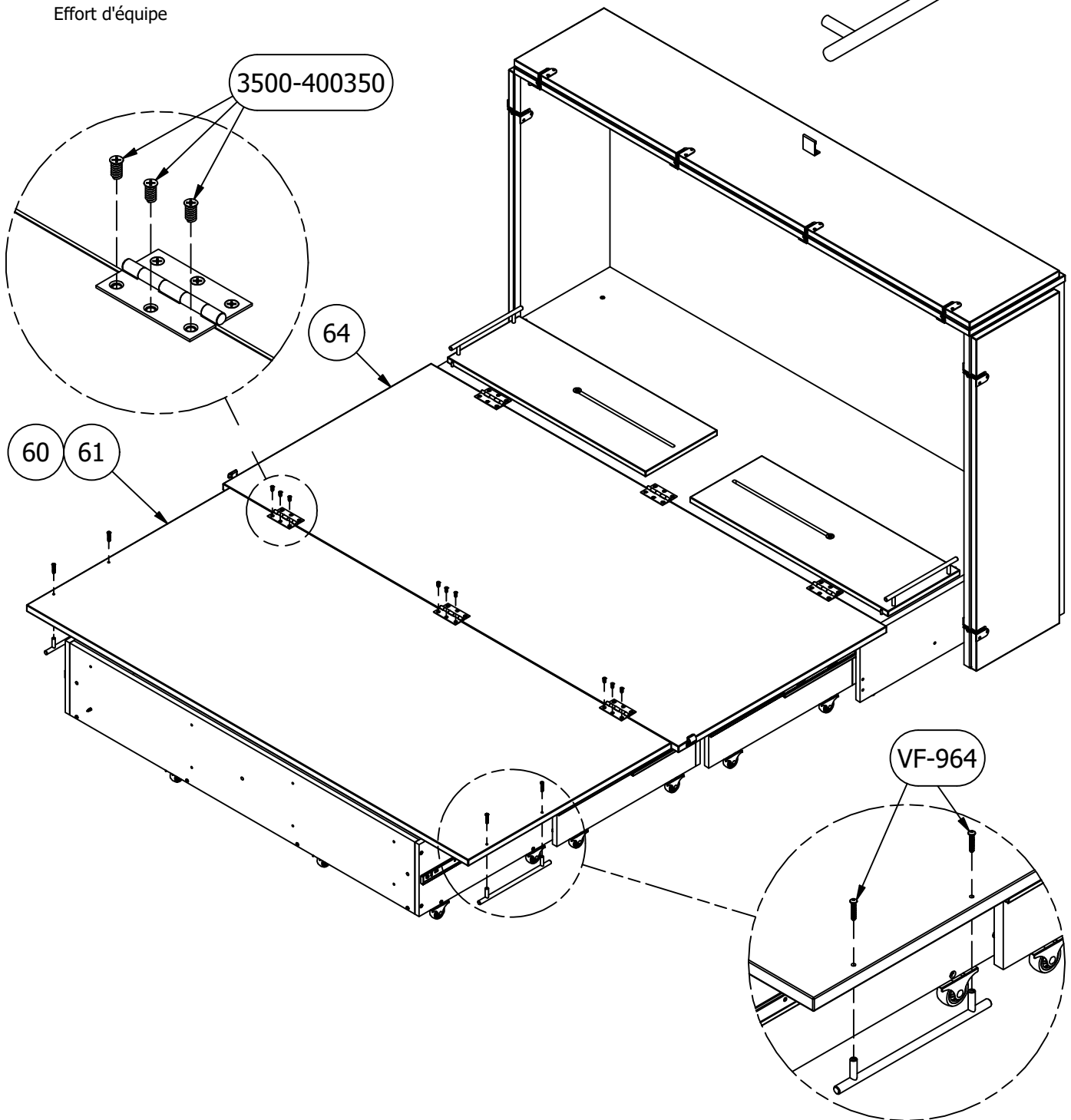

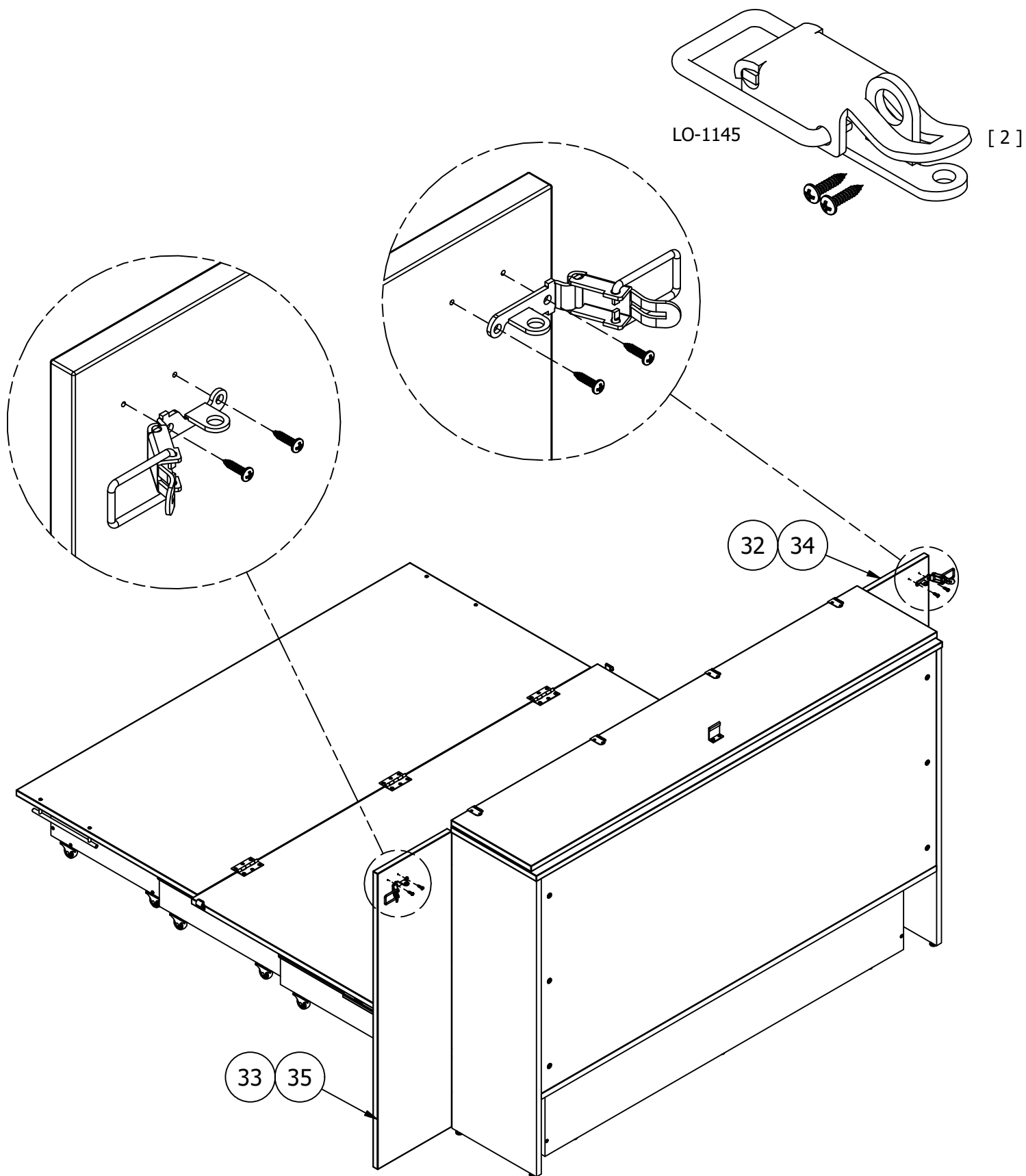

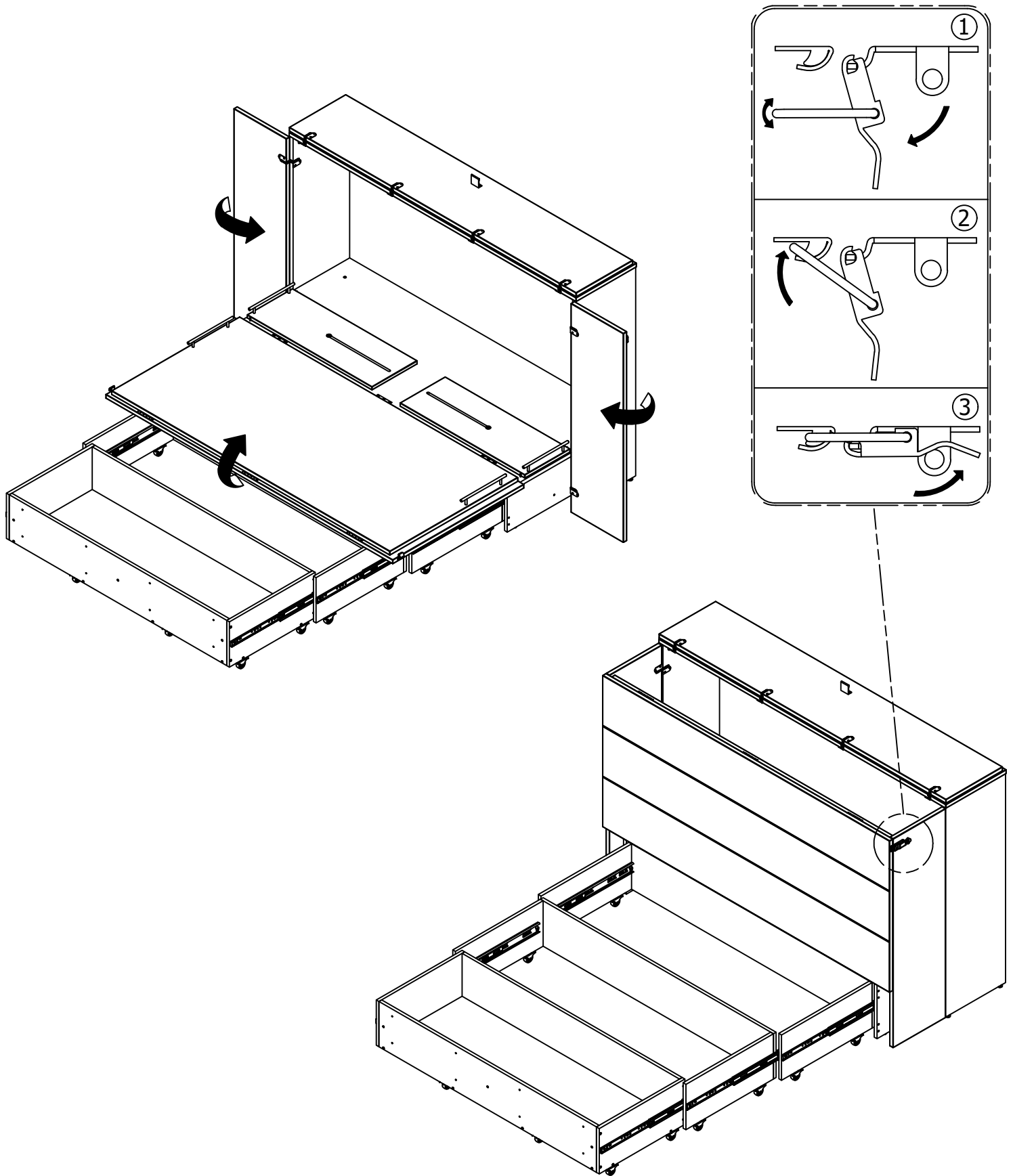

VR-212 [8] VM-601 [2] PO-1040 [1]
#8 x 1" 3/4in (20mm)

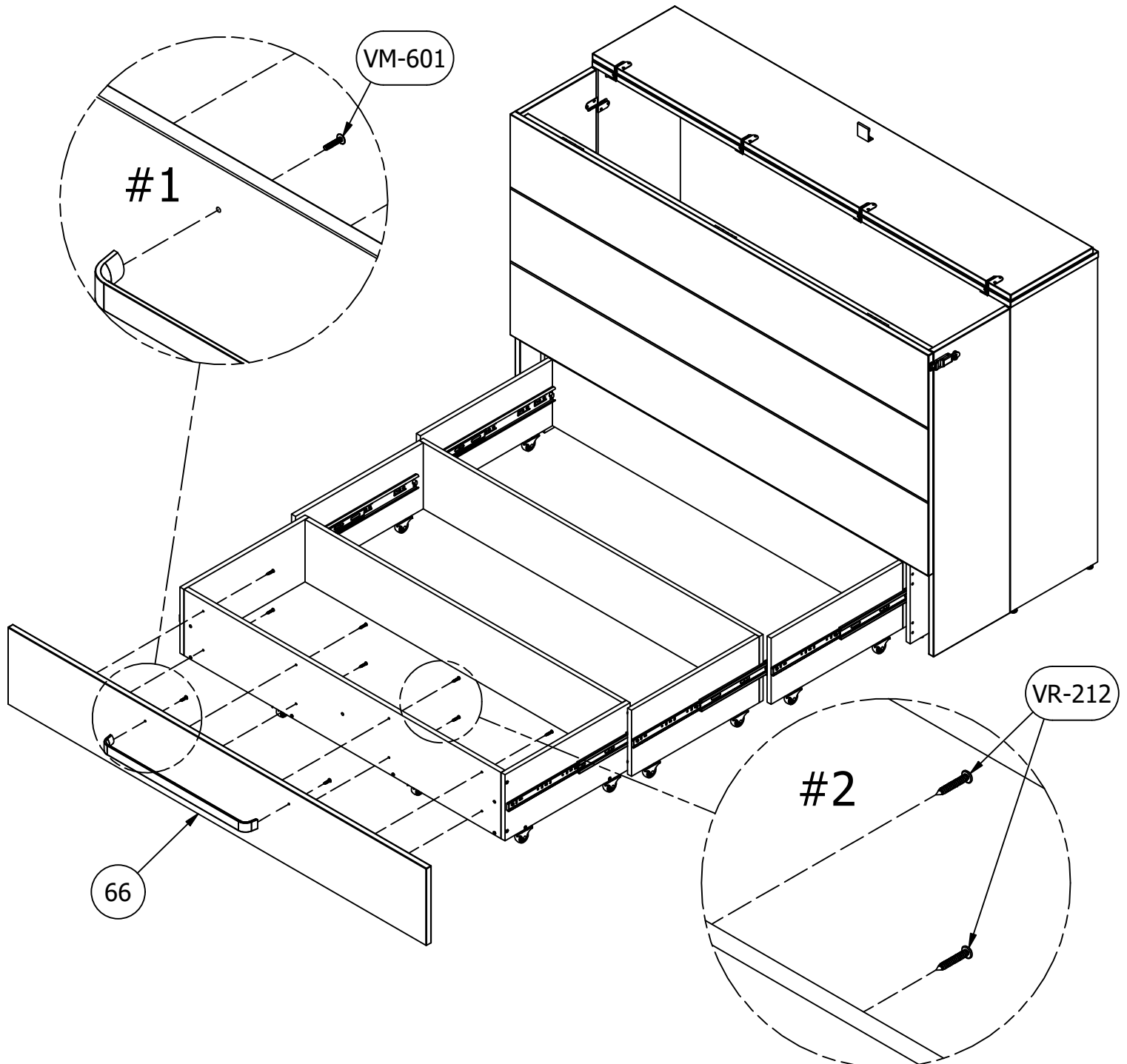

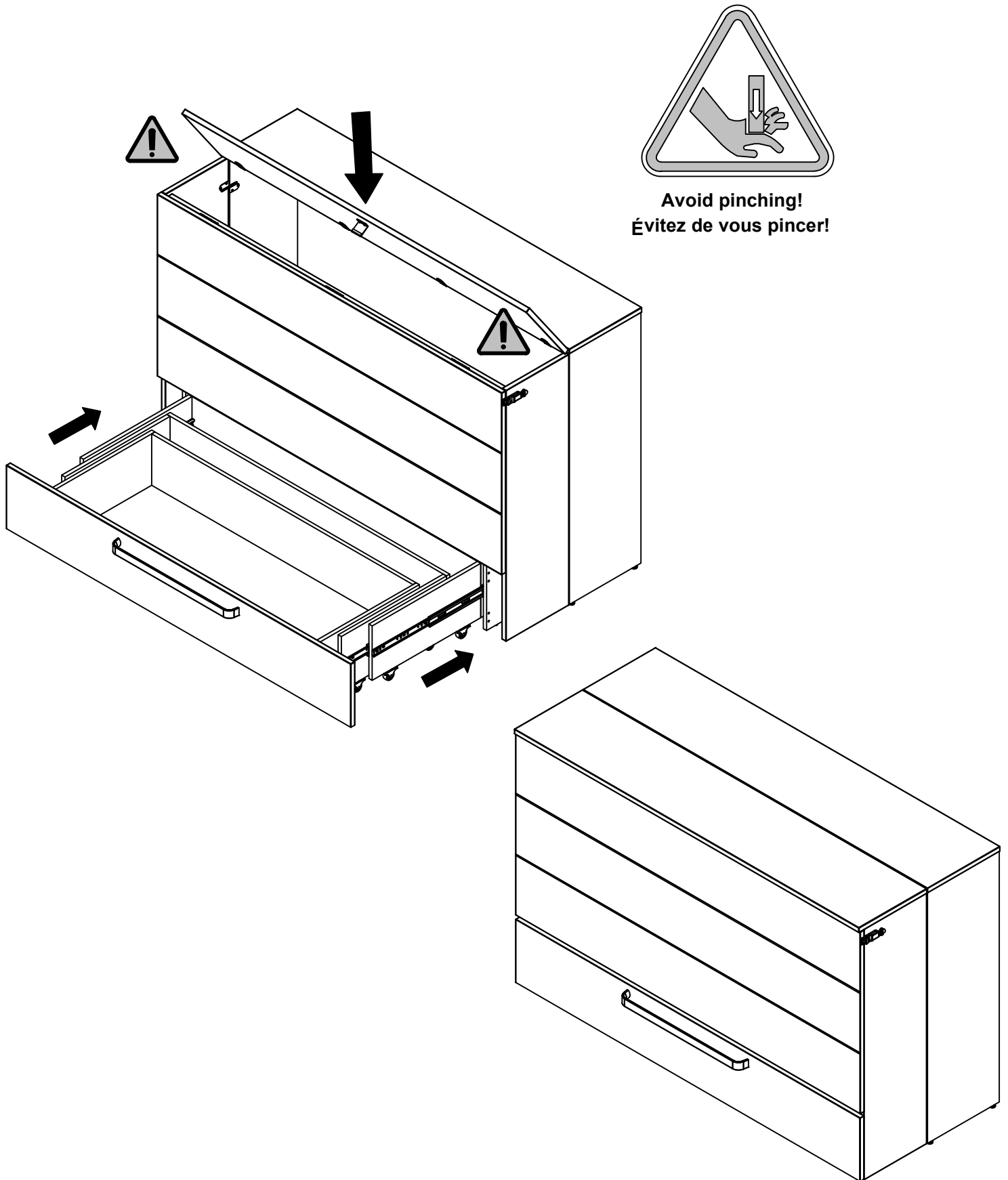

WALL STUD ATTACHMENT

FIJACIÓN A LOS MONTANTES DE LA PARED
 FIXATION AUX MONTANTS DU MUR

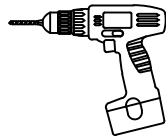

Drill 1/8" hole 2" deep at mark on wall.
 Taladro 1/8 "agujero 2" de profundidad en la marca en la pared.
 Percer 1/8 "trou de 2" de profondeur à la marque sur le mur.

H181434

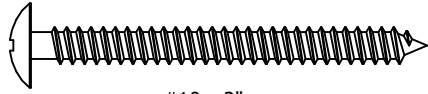

[1]

#10 x 2"

H181412



[1]

Connecting Plate

Wood stud
 Montante de madera
 Stud bois

Drywall
 Paneles de yeso
 cloisons sèches

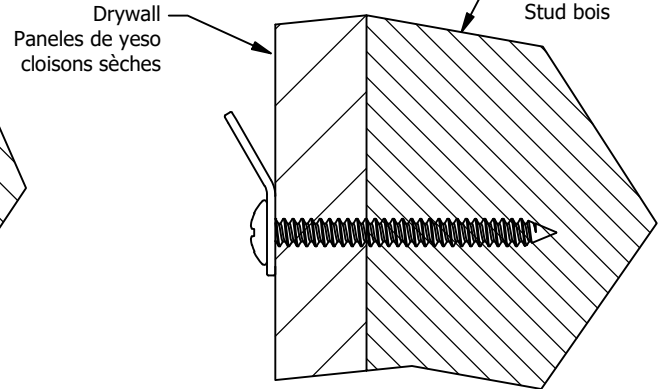
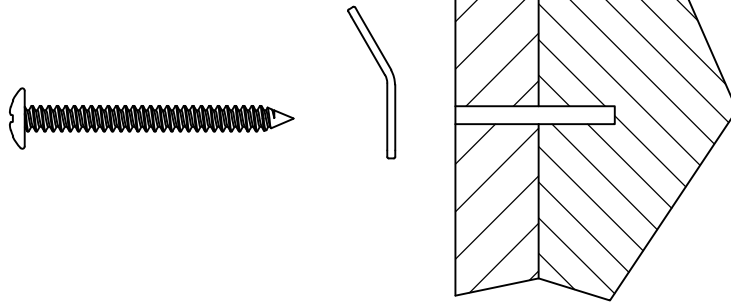

HOLLOW WALL ATTACHMENT

FIJACIÓN A PARED HUECA
 FIXATION SUR MUR CREUX

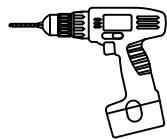

Drill 1/2" hole 1" deep at mark on wall.
 Taladro 1/2 "agujero 1" de profundidad en la marca en la pared.
 Percer 1/2 "trou de 1" de profondeur à la marque sur le mur.

H181419

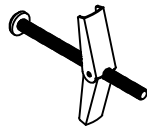

[1]

Toggle Bolt

H181412

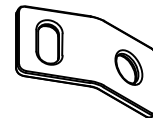

[1]

Connecting Plate

Drywall
 Paneles de yeso
 cloisons sèches

Drywall
 Paneles de yeso
 cloisons sèches

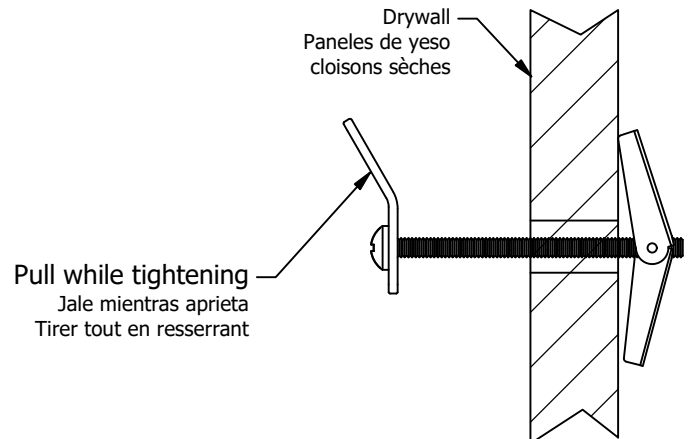
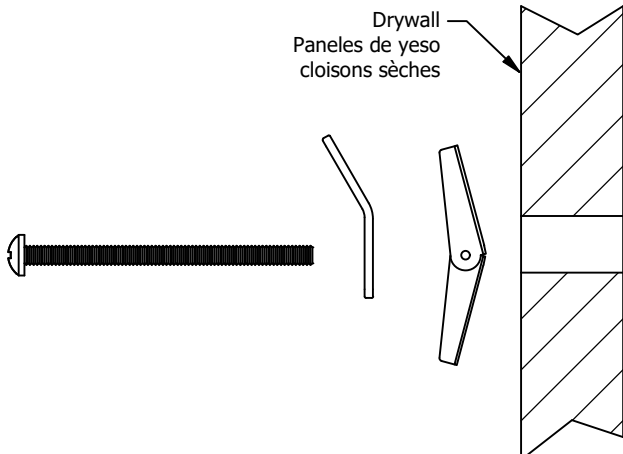

Pull while tightening
 Jale mientras aprieta
 Tirer tout en resserrant

Have an assembly question or need a replacement part? Just call
1-800-950-4782, we are here to help.

**Secure unit to the wall with a tip-over restraint.
Fixer au mur à l'aide d'un dispositif anti-basculement.**

1. Place unit in desired location.
 2. Locate wall stud nearest unit center. **FIG A**
 3. On wall, mark center of stud location 1" below top of unit. **FIG A**
 4. If a wall stud cannot be located mark hollow wall at unit center. **FIG A**
 5. On back of unit, mark corresponding location 3/8" below top of unit. **FIG B**
1. Placer le meuble à l'endroit désiré.
 2. Localiser le montant du mur le plus proche du centre du meuble. **FIG A**
 3. Sur le mur, marquer le centre du montant à 1 po du haut du meuble. **FIG A**
 4. Si un montant mural ne peut être localisé, marquer le mur creux au centre du meuble. **FIG A**
 5. Au dos du meuble, marquer l'emplacement correspondant, à 3/8 po du dessus du meuble. **FIG B**
1. Coloque la unidad en la ubicación deseada.
 2. Localice el montante de pared más cercano al centro de la unidad. **FIG A**
 3. En la pared, marque el centro del montante 1 pulgada por debajo de la parte superior de la unidad. **FIG A**
 4. Si no se puede localizar un montante en la pared, marque la pared hueca en el centro de la unidad. **FIG A**
 5. En la parte posterior de la unidad, marque la ubicación correspondiente 3/8 pulgadas por debajo de la parte superior de la unidad. **FIG B**

FIG A

Mark wall
Marque la pared
Marquez le mur

1" (25mm)

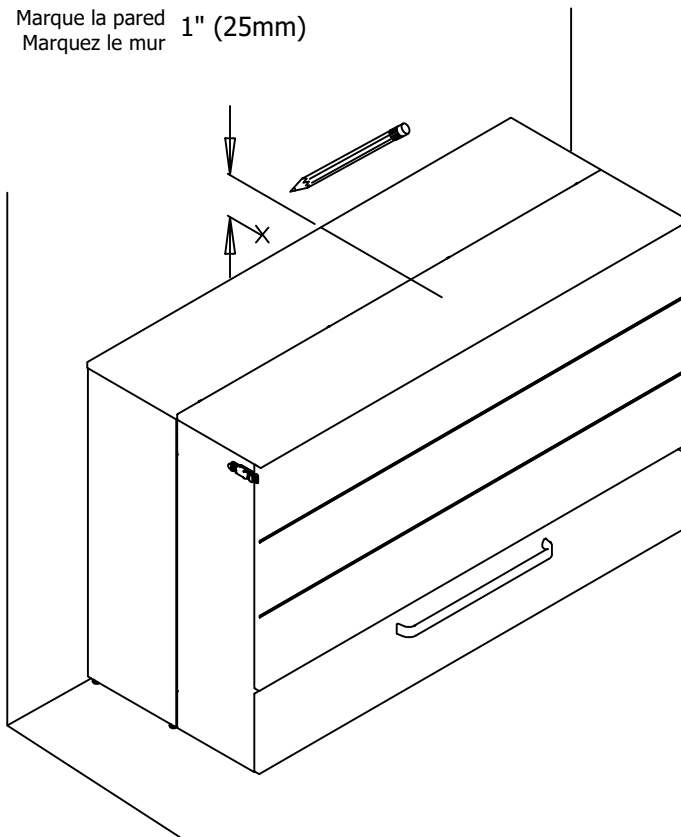
**FIG B**

3/8" (10mm)

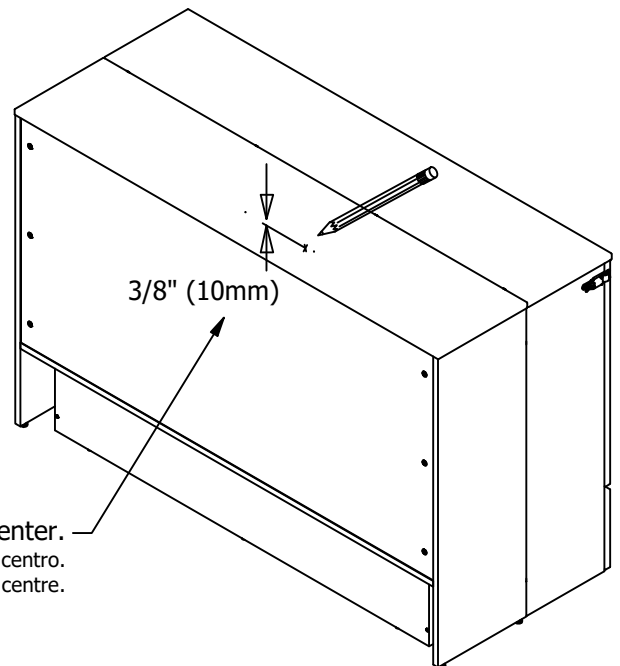

Mark back within 6" (150mm) of center.

Marque la parte trasera del mueble a menos de 6 pulgadas (150 mm) del centro.
Marquer le dos du meuble à moins de 6 po (150 mm) du centre.

Have an assembly question or need a replacement part? Just call
1-800-950-4782, we are here to help.

H107572

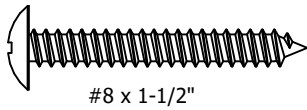

[1]

H181412



[1]

Connecting Plate

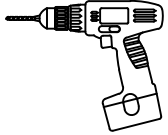

Drill 1/8" hole 1" deep at mark on unit.
Taladro 1/8 "agujero de 1" de profundidad en la marca de la unidad.
Perçer 1/8 "trou 1" de profondeur à la marque sur l'unité.

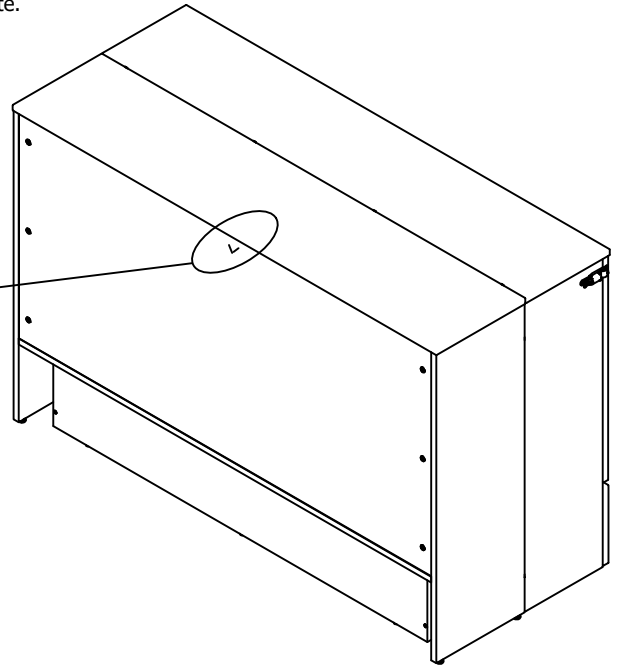
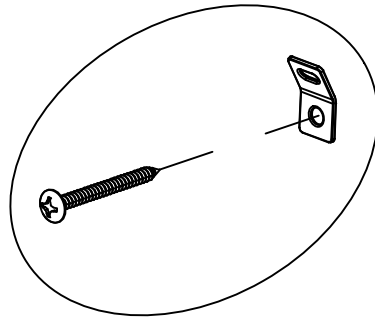

H181411

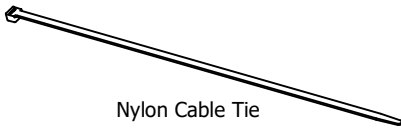

[1]

Nylon Cable Tie

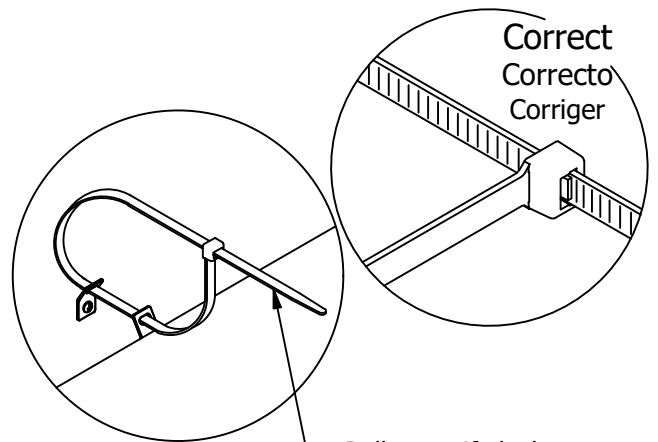
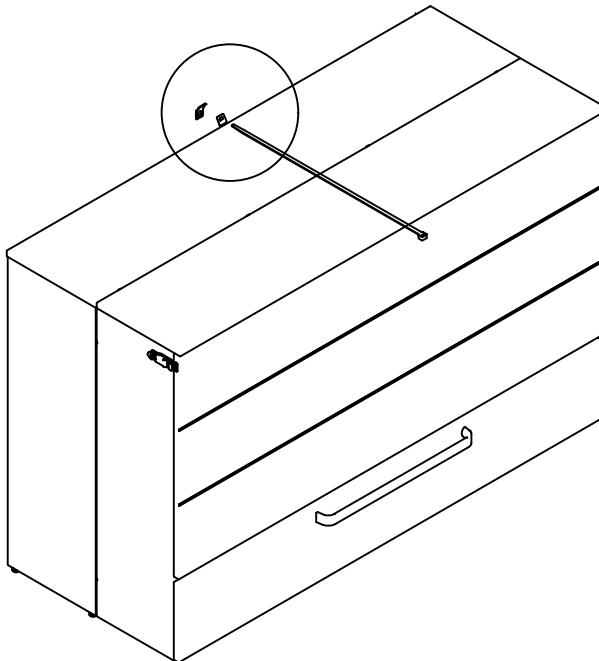

Pull to verify lock
Tire para verificar cerradura
Tirez pour vérifier serrure

Use replacement cable tie with minimum breaking strength of 120lbs.

Utilice reemplazo empate Cable con resistencia a la rotura mínima de 120 libras.
Utilisez remplacement Attache de câble avec une force de rupture minimale de 120 lbs.

Have an assembly question or need a replacement part? Just call
1-800-950-4782, we are here to help.

Follow these steps TO OPEN
Respecter ces étapes POUR OUVRIR

1

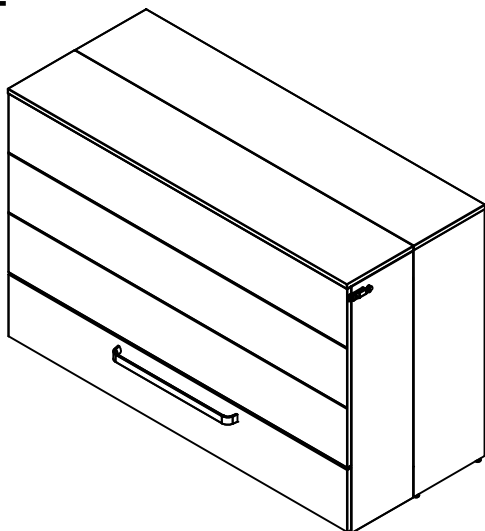

2

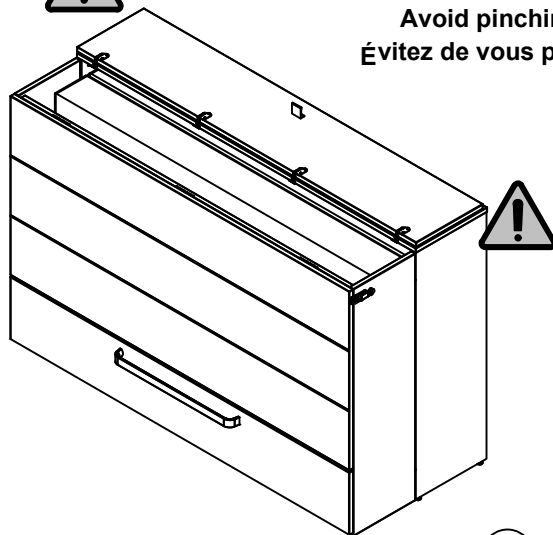

Avoid pinching!
Évitez de vous pincer!



3

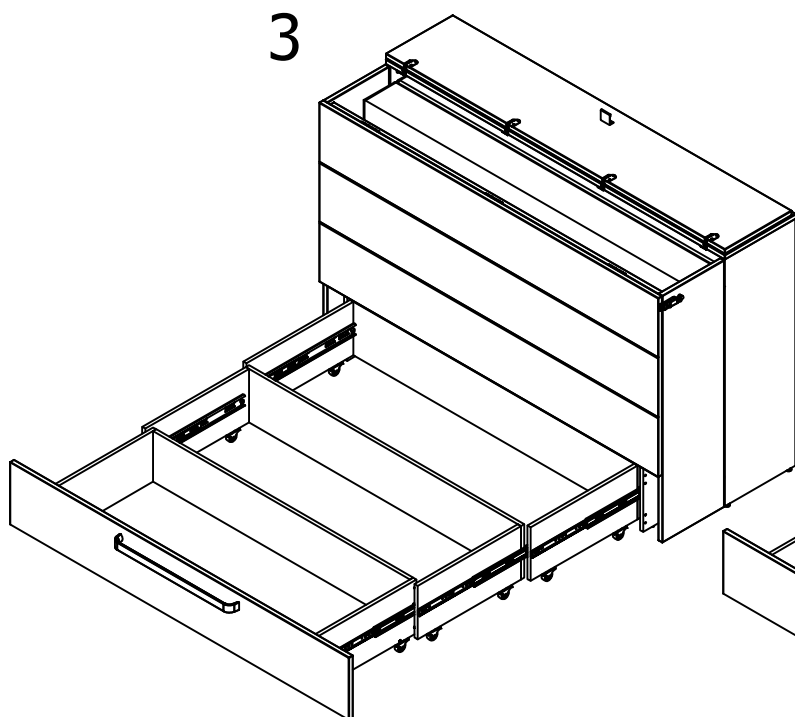

4

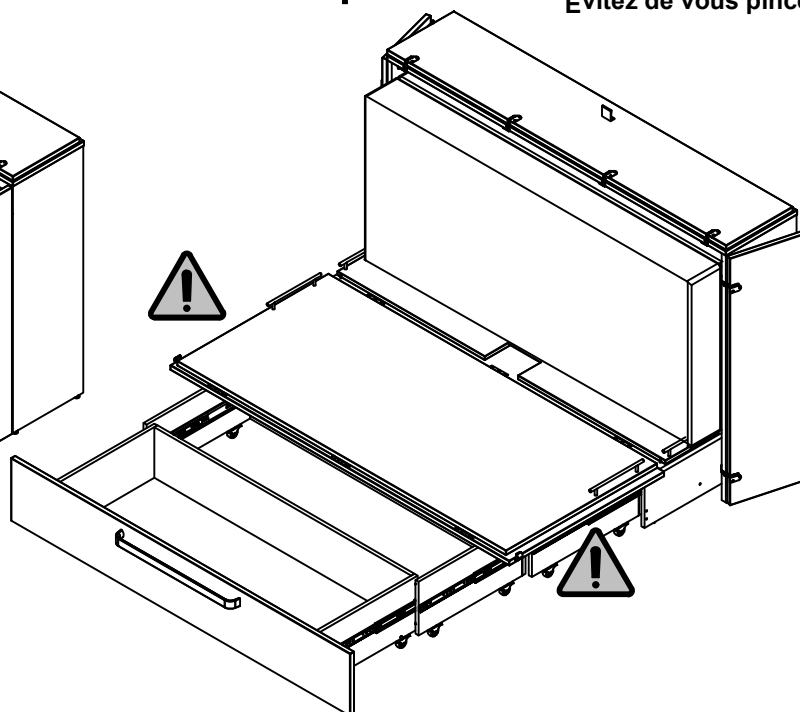

Avoid pinching!
Évitez de vous pincer!



Follow these steps TO OPEN
Respecter ces étapes POUR OUVRIR

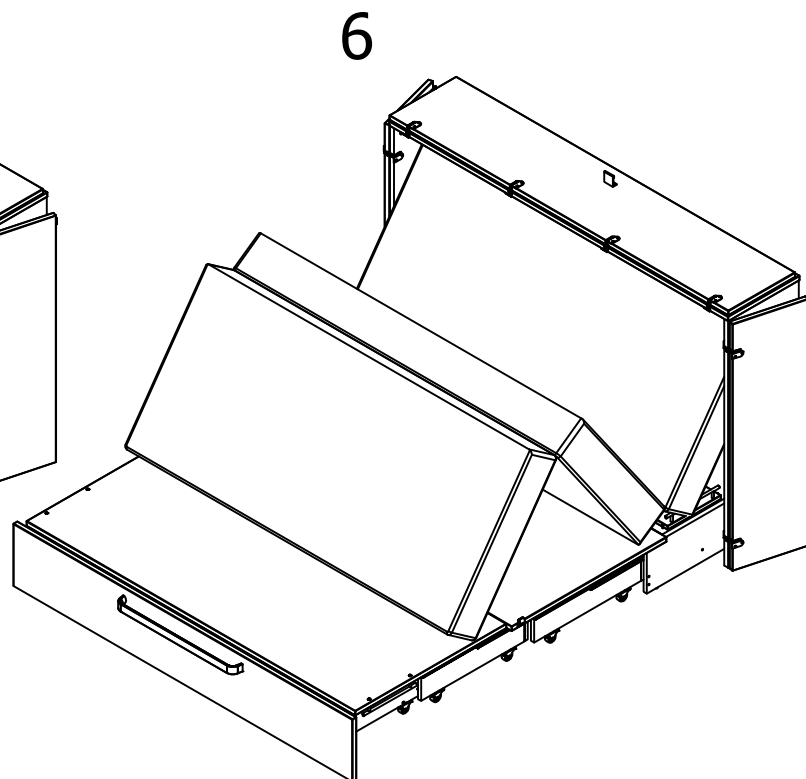
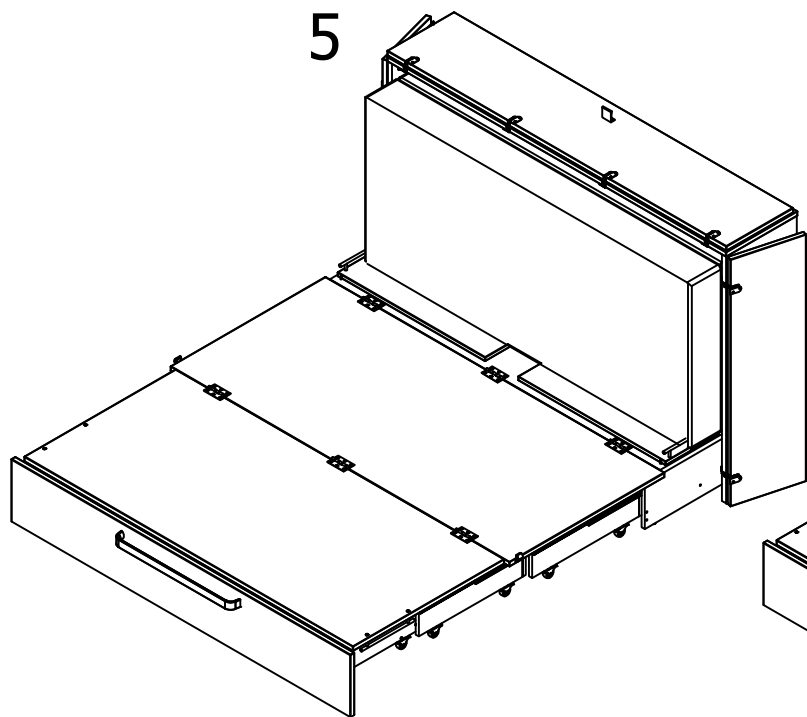

Maximum Weight: 15 Lbs.
Poids Maximum: 6.8 kilogrammes

Maximum Weight: 750 Lbs.
Poids Maximum: 340.2 kilogrammes

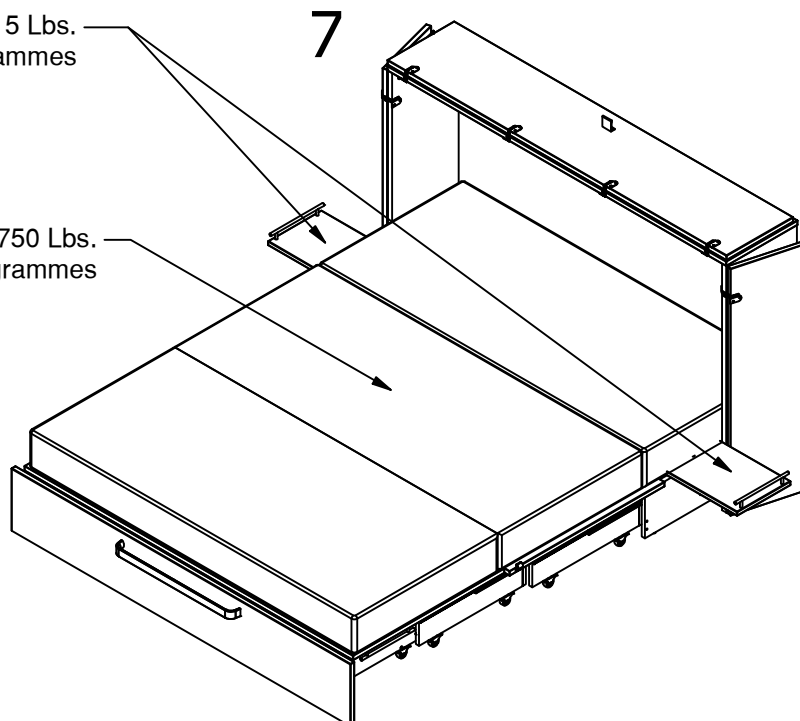

Follow these steps TO CLOSE
Respecter ces étapes POUR FERMER

Maximum Weight: 15 Lbs.
Poids Maximum: 6.8 kilogrammes

1

Maximum Weight: 750 Lbs.
Poids Maximum: 340.2 kilogrammes

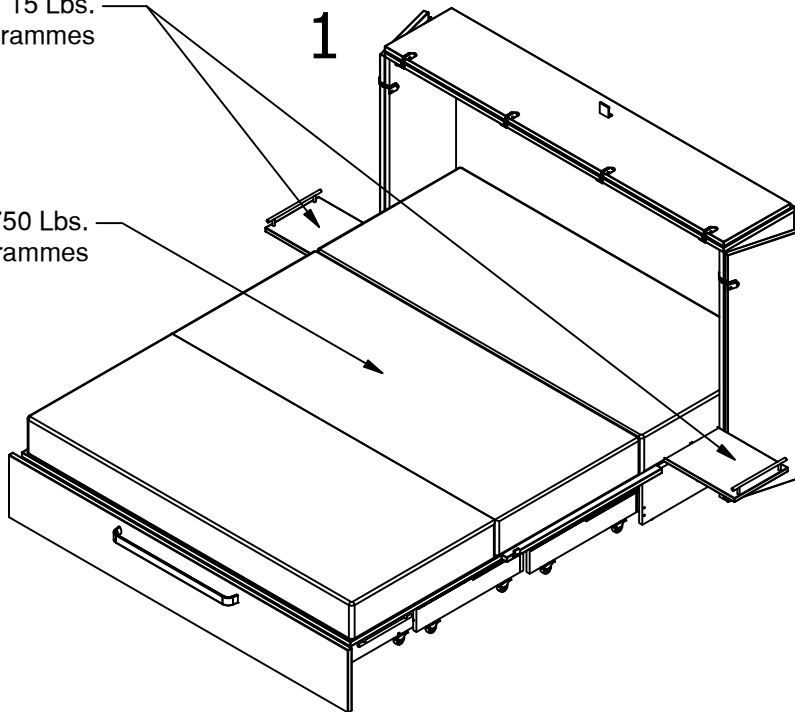

3

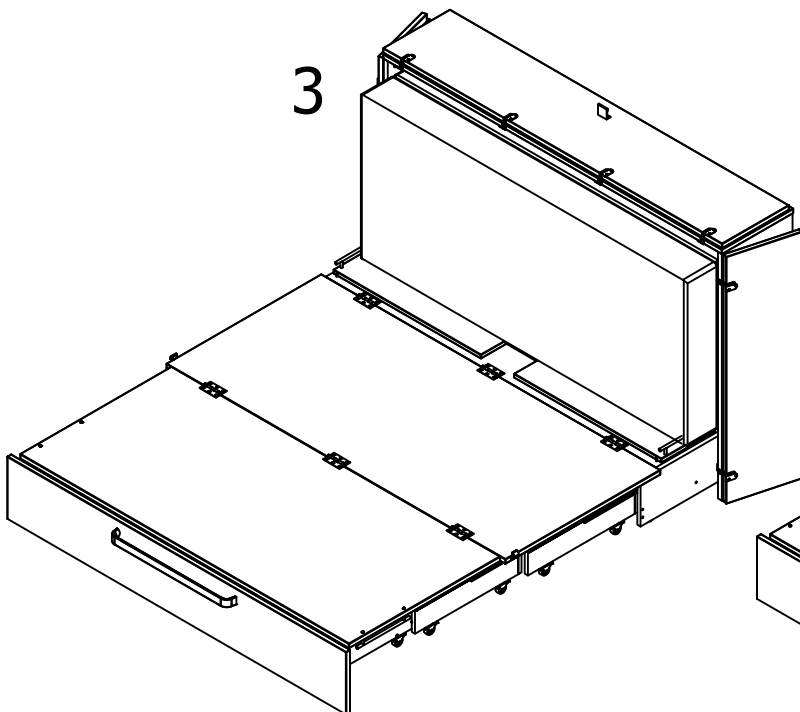

2

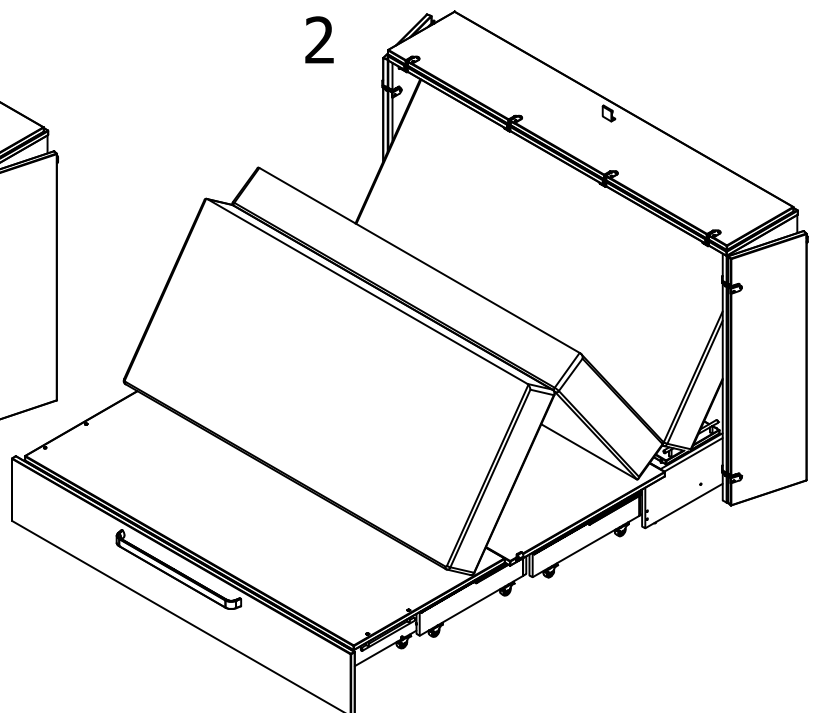

Follow these steps TO CLOSE
Respecter ces étapes POUR FERMER

4

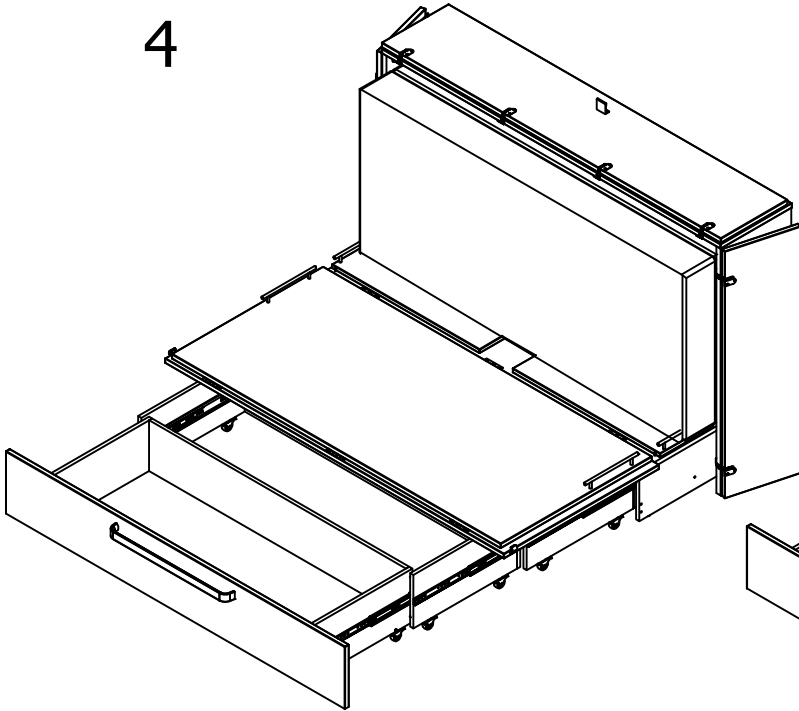

5

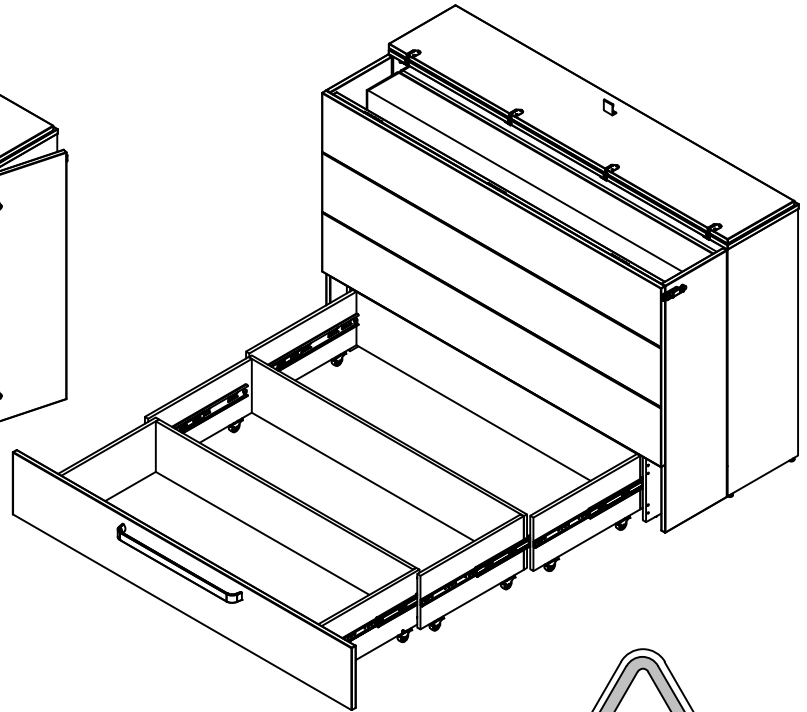

6

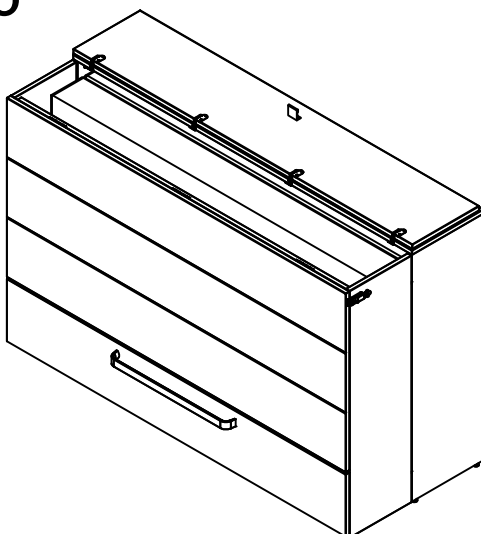

7

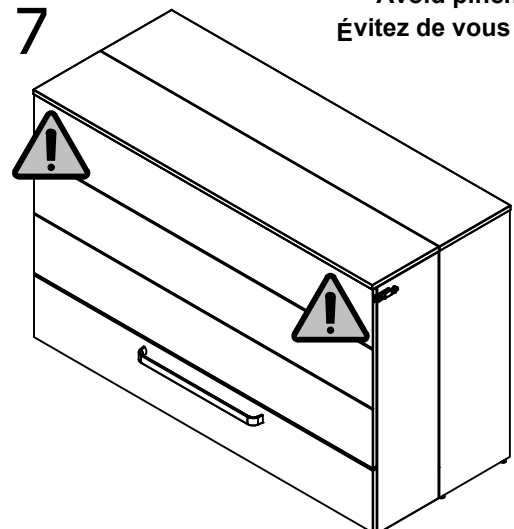

Avoid pinching!
Évitez de vous pincer!