



# WF50BG8300

# SAMSUNG

## 5.0 cu. ft. Extra Large Capacity Smart Front Load Washer with Super Speed Wash and Steam



### Available Colors

-  **Brushed Black**  
WF50BG8300AV
-  **Ivory**  
WF50BG8300AE

### Features

- Extra-Large 5.0 cu. ft. Capacity
- Super Speed Wash
- ENERGY STAR® Most Efficient
- Flexible Installation
- Wi-Fi Connectivity<sup>1</sup>
- Steam
- Antimicrobial Technology
- Self Clean+
- Closet Depth Fit<sup>2</sup>
- Premium Tempered Glass Door
- Vibration Reduction Technology+
- Swirl+ Drum Interior
- Smart Care
- ADA Compliant<sup>3</sup>
- 1200 RPM Maximum Spin Speed
- Direct Drive Motor
- 23 Total Washing Cycles
- 9 Additional Options

### Convenience

- Child Lock
- Dispenser Trays: Main Wash, Softener, Bleach

### Ratings



ENERGY STAR® Most Efficient  
CEE Tier 3  
IMEF = 3.10  
IWF = 2.9  
99 kWh/yr

### Electrical Requirements

120 V / 60 Hz  
15 Amps

<sup>1</sup>Requires wireless network, Samsung account and Samsung SmartThings App. The Samsung SmartThings App supports Android OS 4.0 (ICS) or later which is optimized for Samsung smartphones (Galaxy S and Galaxy Note series). This app also supports iOS 7 or later for iPhone models. Samsung SmartThings App available in App Store and Play Store.

<sup>2</sup>Designed to fit a 40" installation depth.

<sup>3</sup>ADA Compliant when using 27" wide riser. (Riser model codes: WE272NV, WE272NW, WE272NC)

<sup>4</sup>As of 1 April 2026, 10 year warranty is limited to the Digital Inverter Motor of washers purchased on 1 April 2026 or later. A purchase receipt indicating the purchase date is required for a claim. Additional restrictions and limitations apply, see warranty for details.

### Specifications

#### 12 Preset Washing Cycles:

Normal, Heavy Duty, Bedding, Quick Wash, Delicates, Towels, Rinse + Spin, Self Clean+, Steam Sanitize, Steam Normal, Steam Whites, Downloads

#### 11 Downloadable Washing Cycles:

Permanent Press, ActiveWear, Wool, Eco Cold, Colors, Outdoor, Denim, Steam Allergen, Power Steam, Steam Bulky, Power Rinse

#### 9 Additional Washing Options:

Pre Soak, Steam, Delay End, Smart Control, Super Speed, Smart Care, Alarm Off, Child Lock, Spin Only

#### 5 Temperature Settings:

Hot, Warmer, Warm, Cold, Tap Cold

#### 5 Spin Settings:

High, Medium High, Medium, Low, No Spin

#### 5 Soil Settings:

Heavy, Heavy Medium, Normal, Low Medium, Light

#### Warranty

One (1) Year Parts and Labor  
Three (3) Years Stainless Steel Tub (Part Only)  
Ten (10) Years; Washing DIT (Digital Inverter Motor) Motor Part (Part Only)<sup>4</sup>

#### Product Dimensions & Weight (WxHxD)

Dimensions: 27" x 38<sup>3</sup>/<sub>4</sub>" x 33<sup>1</sup>/<sub>2</sub>"  
Weight: 216.1 lbs

#### Shipping Dimensions & Weight (WxHxD)

Dimensions: 29<sup>3</sup>/<sub>8</sub>" x 42<sup>3</sup>/<sub>8</sub>" x 35<sup>3</sup>/<sub>8</sub>"  
Weight: 220.5 lbs

Washer	Model #	UPC Code
Brushed Black	WF50BG8300AV	887276660912
Ivory	WF50BG8300AE	887276660905

#### Matching Electric Dryer

Brushed Black	DVE50BG8300V	887276660875
Ivory	DVE50BG8300E	887276660868

#### Matching Gas Dryer

Brushed Black	DVG50BG8300V	887276660899
Ivory	DVG50BG8300E	887276660882

Optional Accessories	Model #	UPC Code
Brushed Black Pedestal	WE402NV	887276310145
Ivory Pedestal	WE402NE	887276529073
Brushed Black Riser	WE272NV	887276197630
Stacking Kit	SKK-8K	887276344034

WF50BG8300

SAMSUNG

## 5.0 cu. ft. Extra Large Capacity Smart Front Load Washer with Super Speed Wash and Steam

### Dimensions

Required dimensions for installation with pedestal:

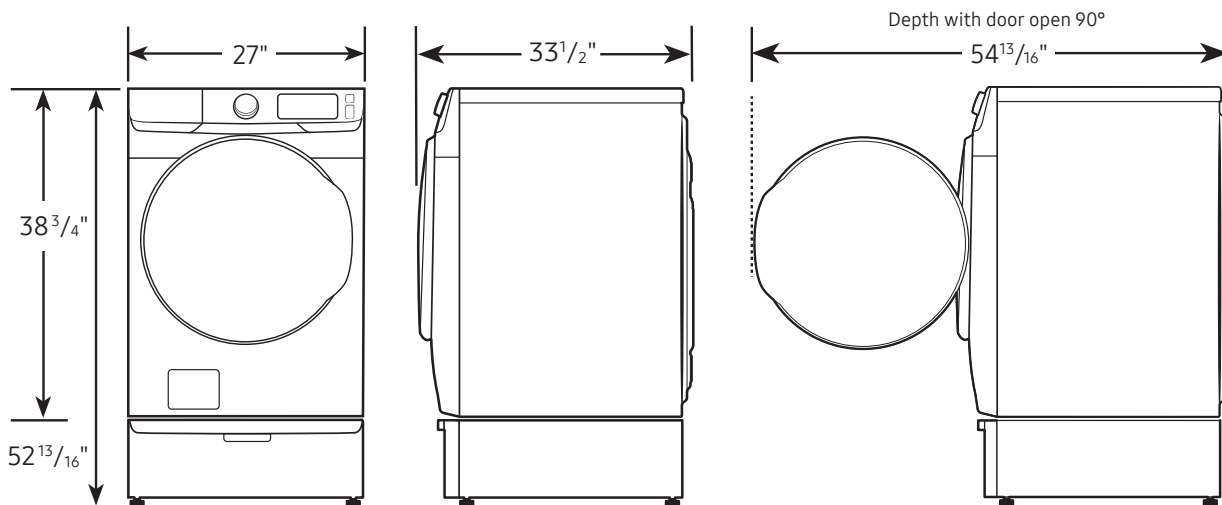

### Installation Specifications – Side-by-Side

If the washer and dryer are installed together or the dryer alone, the closet front must have two unobstructed air openings for a combined minimum total area of 72-inch<sup>2</sup>. Your washer alone does not require a specific air opening.

Alcove or closet installation

Minimum clearance for closet and alcove installations:

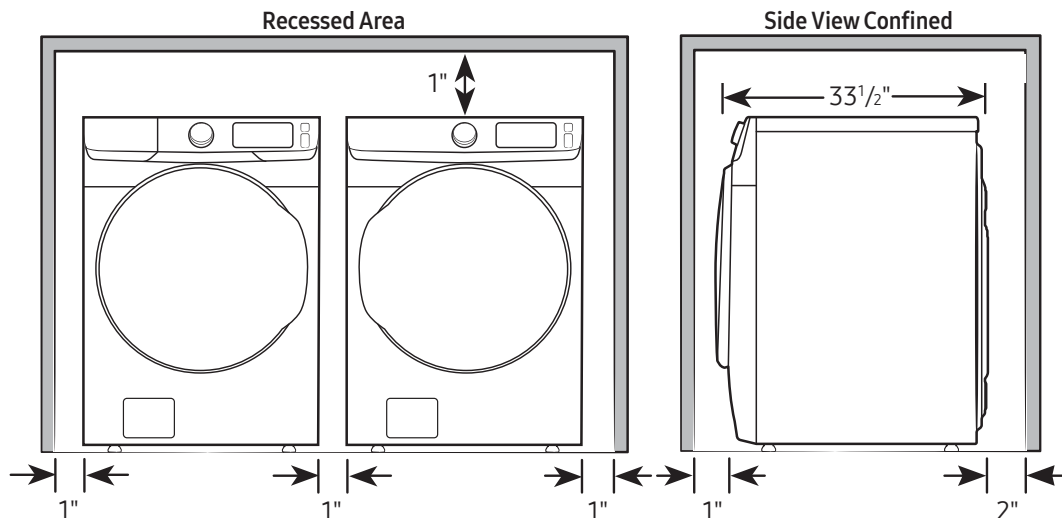

### Connection Dimensions

Back view of washer

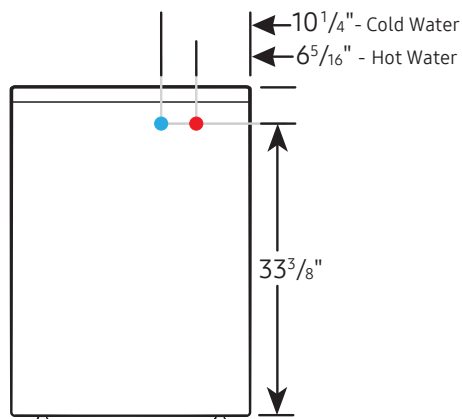

#### LEGEND:

- Cold Water Connection
- Hot Water Connection

Actual color may vary. Design, specifications, and color availability are subject to change without notice. Non-metric weights and measurements are approximate.

©2026 Samsung Electronics America, Inc., 85 Challenger Road, Ridgefield Park, NJ 07660. Tel: 800-SAMSUNG.samsung.com. Samsung is a registered trademark of Samsung Electronics Co., Ltd.

WF50BG8300

SAMSUNG

# 5.0 cu. ft. Extra Large Capacity Smart Front Load Washer with Super Speed Wash and Steam

## Installation Specifications – Stacked Pair

Clearances indicated are for stacked pairs. The closet front must have two unobstructed air openings for a combined minimum total area of 72-inch<sup>2</sup>.

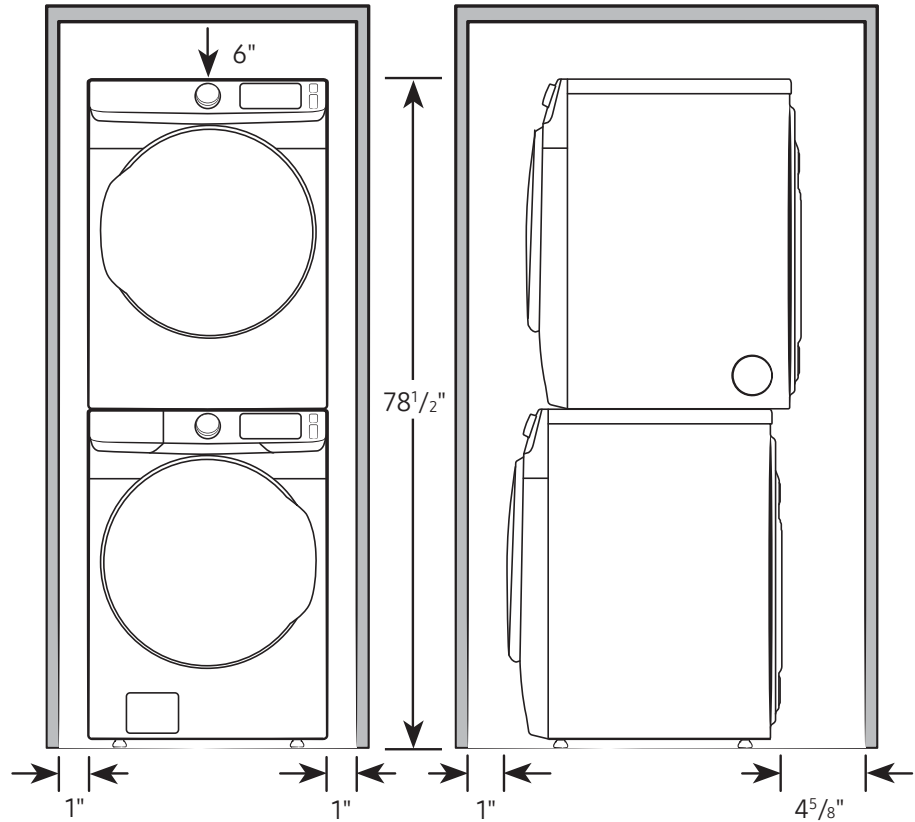

## Connection Dimensions

Back and side views of stacked pair

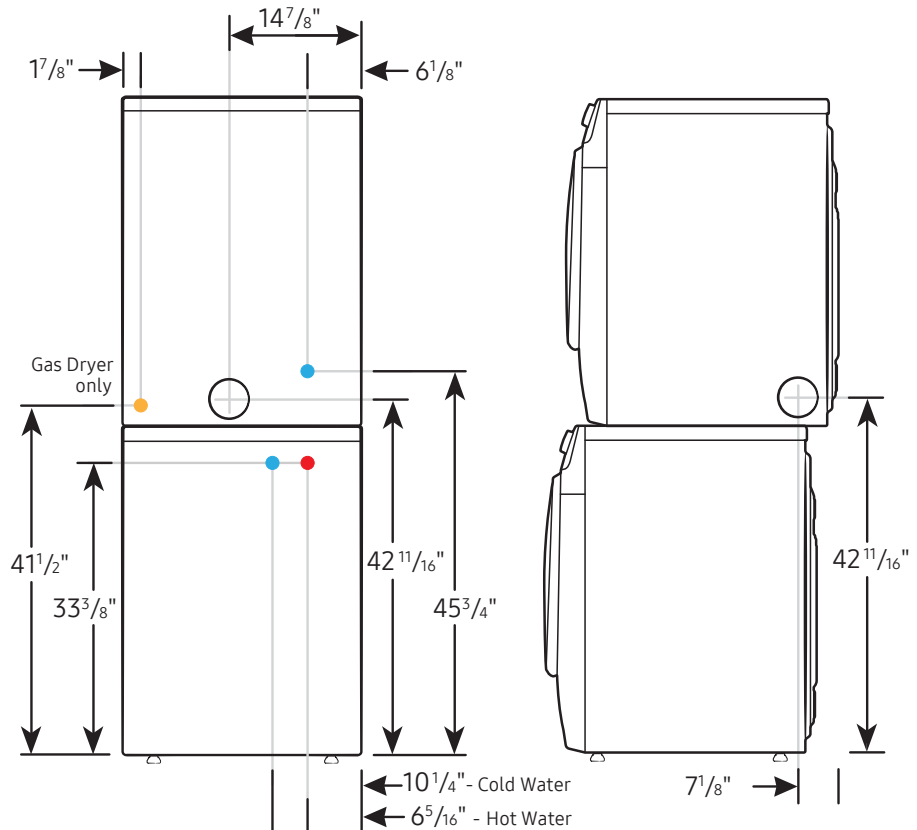

- LEGEND:**
- Cold Water Connection
  - Hot Water Connection
  - Gas Connection

Actual color may vary. Design, specifications, and color availability are subject to change without notice. Non-metric weights and measurements are approximate.

©2026 Samsung Electronics America, Inc., 85 Challenger Road, Ridgefield Park, NJ 07660. Tel: 800-SAMSUNG.samsung.com. Samsung is a registered trademark of Samsung Electronics Co., Ltd.