

AIR650 Airbike Pro OWNER'S MANUAL

PLEASE CAREFULLY READ THIS ENTIRE MANUAL BEFORE OPERATING YOUR NEW AIRBIKE PRO

Table Of Contents

Product Registration	1
Important Safety Instructions	2
Important Operation Instructions	3
AIR650 Assembly Instructions	4
Final Preparations	9
Exploring your new Bike	11
Console Programs	13
Heart Rate Information	15
Manufacturer's Limited Warranty	18

WARRANTY COMPLIANCE

THIS INDOOR CYCLE IS INTENDED FOR RESIDENTIAL USE ONLY AND IS WARRANTED FOR THE APPLICATION. ANY OTHER APPLICATION VOIDS THIS WARRANTY IN ITS ENTIRETY.



Congratulations On Your New Airbike Pro and Welcome to the XTERRA Fitness Family!

Thank you for your purchase of this quality indoor cycle. Your new Airbike Pro has been manufactured by one of the leading fitness manufacturers in the world and is backed by one of the most comprehensive warranties available. **XTERRA Fitness** will do all we can to make your ownership experience as pleasant as possible for many years to come.

If you have any questions about your new product or questions about the warranty contact **XTERRA Fitness** at **1-800-258-8511**. If you have a technical problem with your new Airbike Pro contact **XTERRA Fitness** technical service at **800-258-8511**.

Please take a moment to record where you purchased your machine, as well as the date of purchase for future reference. We appreciate your confidence in **XTERRA Fitness** and we will always remember that you are the reason that we are in business. Please complete and mail your registration card today and enjoy your new Airbike Pro.

Yours in Health,
XTERRA Fitness

Purchase Location _____

Purchase Date _____

Product Registration

Record Your Serial Number

Please record the Serial Number of this fitness product in the space provided below.

Serial Number _____

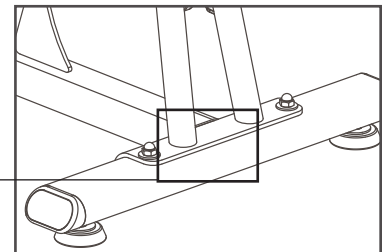

Register Your Purchase

The self-addressed product registration card must be completed in full and returned to **XTERRA Fitness**. You can also go to www.xterrafitness.com/support/warrantyreg/ to register online.

AIR650_20210125
Version 5.0

Important Safety Instructions

WARNING - Read all instructions before using this appliance.

1. Use this equipment only for its intended use as described in this manual. Do not attempt to ride this bike at high pedal speeds until you have ridden the bike for some time and are comfortable riding at slower pedal speeds.
2. Wait for flywheel to coast to a stop before dismounting the bike.
3. Serious injury or death may occur from over-training. Consult a medical doctor or qualified fitness instructor to determine an exercise program appropriate for your level of fitness.
4. Do not attempt to turn the pedal cranks by hand. Do not touch any driving mechanism while it is in motion as possible injury could occur.
5. In a home setting, keep children away from the bike when it is not in use. Keep children and pets away from the unit while it is in use.
6. Do not attempt to perform dip movements on handlebars.
7. Never drop or insert any object into any opening of the bike.
8. Only use the bike on a stable, level floor.
9. Follow instructions for safe use of the equipment including proper seat position, handlebar position, and use of foot positioning system of pedals. Do not attempt to pull up handlebar post and seat post over the 'MAX.' graduation.
10. For safe operation, allow for at least 1 foot (30cm) of free space to either side of the unit and 2 feet (60cm) of free space to the rear of the unit.
11. Weight Limit: 350 lbs.

Regularly examine the bike for damage and wear. Inoperable components should be replaced immediately or the equipment should not be used until it is repaired.

Failure to follow all guidelines may compromise the effectiveness of the exercise experience, expose yourself (and possibly others) to injury, and reduce the longevity of the equipment.



WARNING: This product can expose you to chemicals including Toluene and Acrylamide which are known to the State of California to cause cancer and birth defects or other reproductive harm. For more information go to www.P65Warnings.ca.gov

SAVE THESE INSTRUCTIONS - THINK SAFETY!

Important Operation Instructions

WARNING - AS THE OWNER OF THIS EXERCISE EQUIPMENT, YOU SHOULD INSIST THAT ALL USERS FOLLOW THE SAME GUIDELINES: YOU SHOULD MAKE THIS MANUAL AVAILABLE TO ALL USERS.

1. Obtain a complete physical examination from your medical doctor and enlist a health/fitness professional's aid in developing an exercise program suitable for your current health status.
2. When working out for the first time, start out slowly for a minimum of five minutes. After your muscles are warmed up, gradually increase the pedaling speed and/or resistance.
3. The speed and duration of your exercise program should always be subject to how you feel. Never permit peer pressure to exceed your personal judgment while exercising.
4. This exercise equipment is not intended for use by persons with reduced physical, sensory or mental capabilities, or lack of experience and knowledge.
5. Overweight or severely de-conditioned individuals should be particularly cautious when using the equipment for the first time. Even though such individuals may not have histories of serious physical problems, they may perceive the exercise to be far less intense than it really is, resulting in the possibility of overexertion or injury.
6. Proper installation and regular maintenance are required to ensure user's safety. Maintenance is the sole responsibility of the owner.

AIR650 Assembly Pack Checklist

ASSEMBLY TOOLS

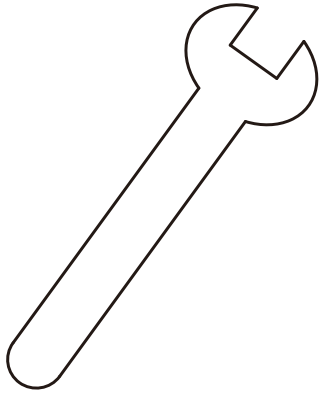

#94. 10mm Wrench
(1 pc)

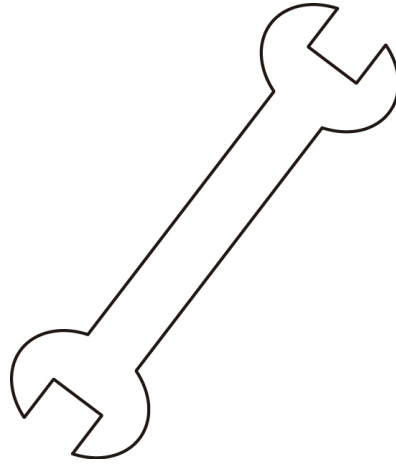

#95. 22x190mm Wrench
(1 pc)

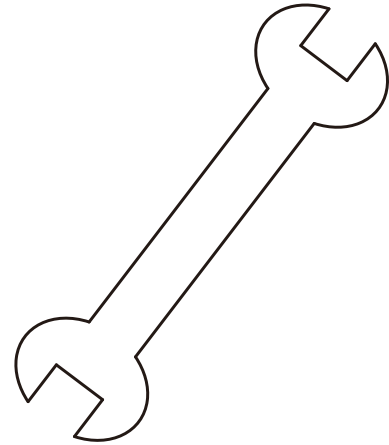

#100. 14/15mm Wrench
(1 pc)

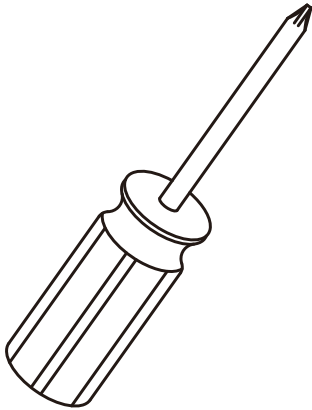

#93. Phillips Head Screw driver
(1 pc)

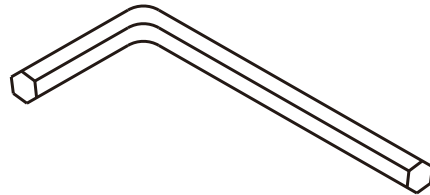

#126. M4 L Allen Wrench
(1 pc)

AIR650 Assembly Pack Checklist

STEP 1.

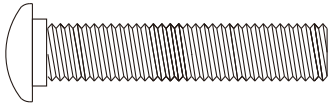

#50. 3/8" × 2"
Carriage Bolt
(2pcs)

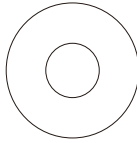

#71. 3/8" × 25 × 2T
Flat Washer
(4pcs)

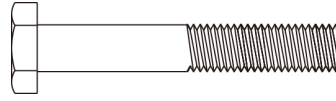

#84. 3/8" × 2-1/4"
Hex Head Bolt
(2pcs)



#135. 3/8"
Cap Nut
(2pcs)

STEP 2.



#90. M6 × 10mm
Phillips Head Screw
(3pcs)

STEP 3.

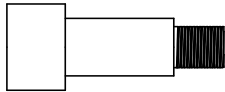

#136. M8 × 20mm
Bolt
(2pcs)



#75. M6 × 6T
Nyloc Nut
(2pcs)

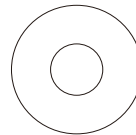

#81. 5/16" × 20 × 3T
Flat Washer
(2pcs)

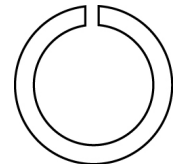

#148. M16 x 3T
Spring Washer
(2pcs)

STEP 4.

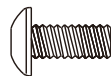

#58. M5 × 12L
Phillips Head Screw
(4cs)

1

Stabilizers

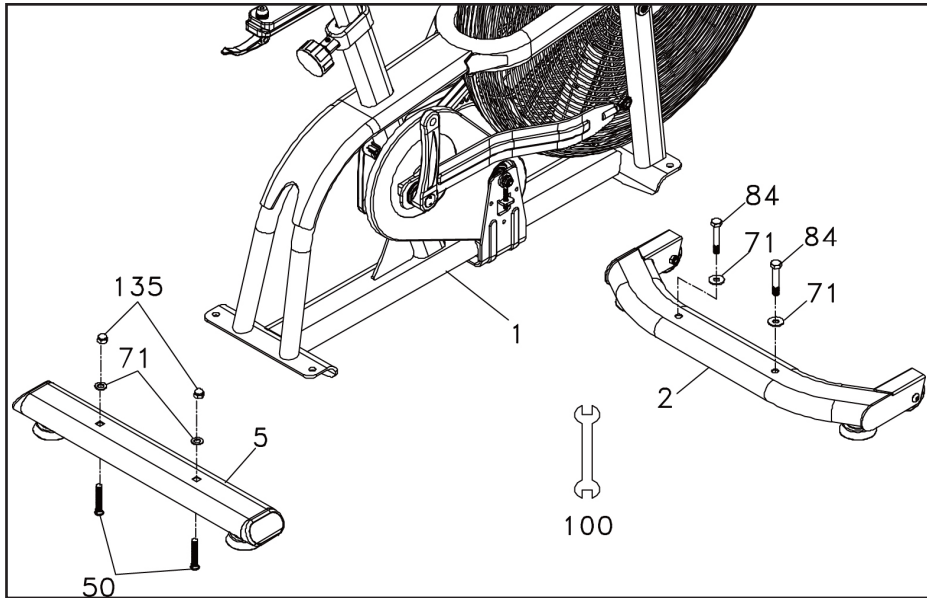

Hardware Step 1

- #84. Hex Head Bolts (2 pcs)
- #50. Carriage Bolts (2 pcs)
- #71. Flat Washers (4 pcs)
- #135. Cap Nuts (2 pcs)

1. Using the 14/15mm wrench (100) fasten the front stabilizer (2) onto the main frame (1) with two sets of hex head bolts (84) and flat washers (71). Slide a washer onto the bolt and place it through the aligned holes in the front stabilizer. Only tighten slightly until you are able to make sure that both bolts fit into place, then you may fully tighten.
2. Use the same wrench to fasten the rear stabilizer (5) onto the main frame (1) with two sets of carriage bolts (50), flat washers (71), and cap nuts (135). Align the holes on the rear stabilizer, slide a bolt through the holes from the bottom. Then add a washer and the cap nut. You may need to press against the bolt if there is any slippage.

2

Console Base

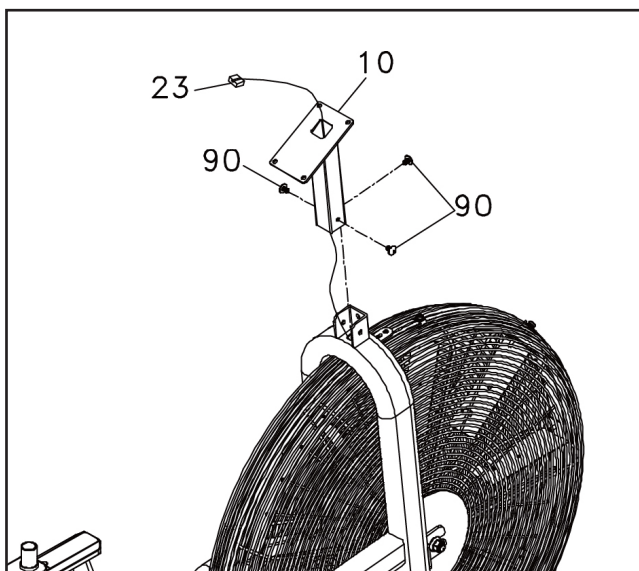

Hardware Step 2

- #90. Phillips Head Screws (3pcs)

1. Above the flywheel is a computer cable (23), feed the cable carefully through the console base (10). Be careful to not pinch or break the wire as it controls the console input.
2. Use the screw driver (93) to fasten the console base (10) onto the main frame (1) with three phillips head screws (90).

You may find it helpful to gently pull the cable to one of the corners of the base so it does not get pinched in-between the screws.

3 Left & Right Handlebars

Hardware Step 3

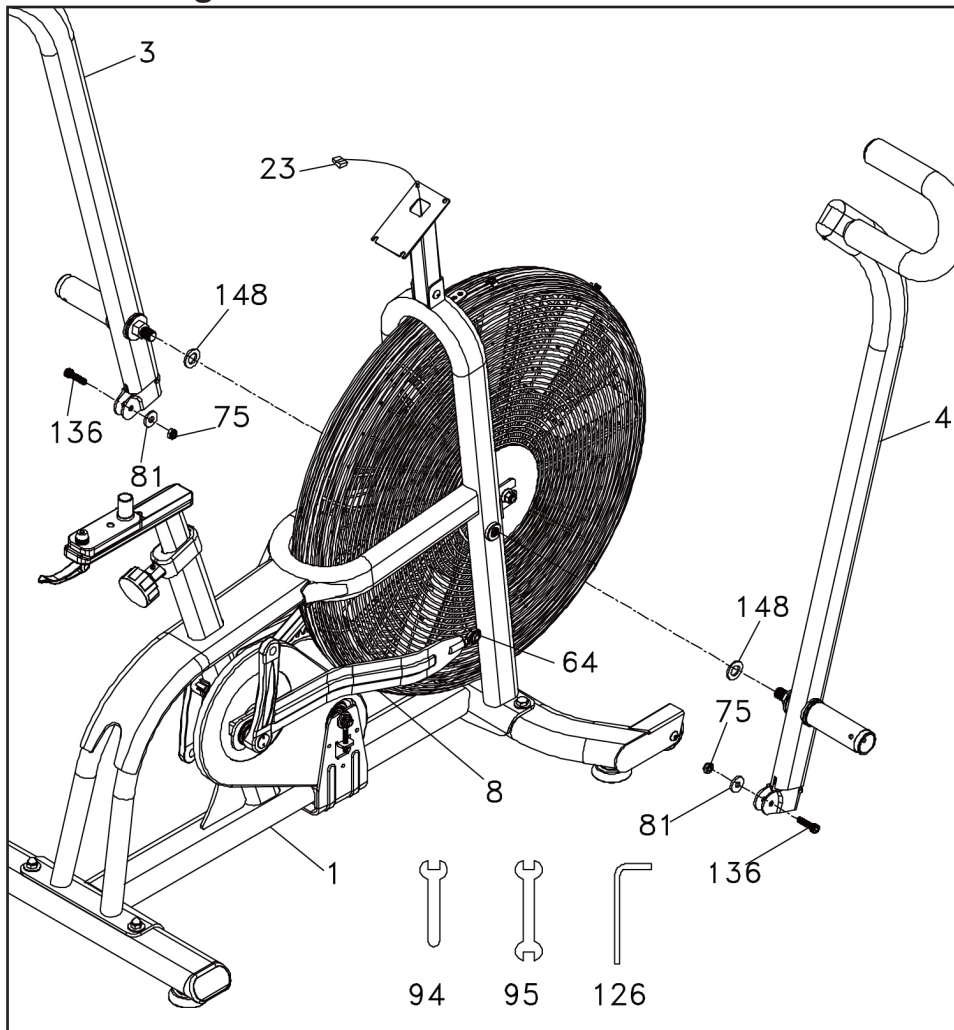

- #136. Bolt (2 pcs)
- #81. Flat Washer (2 pcs)
- #75. Nyloc Nut (2 pcs)
- #148. Spring Washer (2pcs)

1. Using the wrench (95) fasten the left handlebar (3) and right handlebar (4) onto the main frame (1) using a Spring Washer (148) for each side.
2. Attach the right handlebar (4) by aligning the end of the right handlebar to fit over the Rocker Link (8) the higher post into the hole on the main frame around the center of the flywheel. Once aligned, slide a Bolt (136) through the Rod End Bearing (64) and fasten with a Flat Washer (81) and a Nyloc Nut (75). Repeat for the left side.
3. Use the 10mm wrench (94) and an Allen wrench (126) to secure all bolts and washers.

4

Console, Pedals, Seat

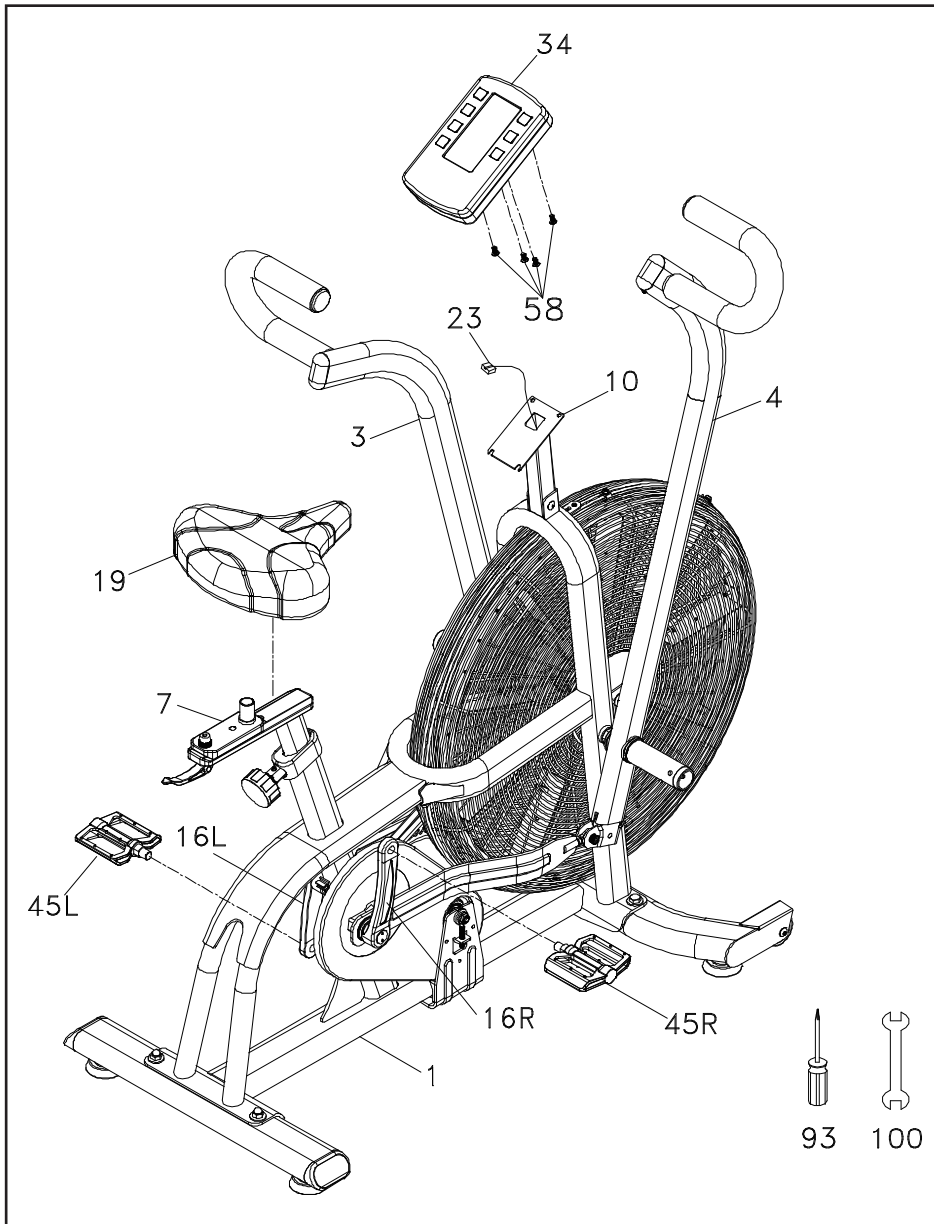

1. Carefully connect the Computer Cable (23) to the Console set (34). Be sure to add in 4 AA batteries before installing.
2. Use the phillips screw driver (93) fasten the console set (34) onto the console base (10) with four screws (58).
3. Use the wrench (100) to fasten the left pedal (45L) onto the left crank arm (16L) and right pedal (45R) onto the right crank arm (16R) respectively.
Note: The right pedal should be threaded on clockwise and the left pedal on counter-clockwise.
4. Use the wrench (100) to fasten the seat (19) onto the sliding seat mount (7).

CHECK ALL BOLTS AND NUTS ARE TIGHTENED BEFORE USING THE MACHINE.

Final Preparations

- Tighten all bolts/nuts securely to complete your installation.
- Adjust all four levelers so your unit sits flat on the ground for a stable ride. If placing on a mat or on carpet, then it may take time for your unit to settle into the floor padding and will not feel as stable as if placed on a hard surface.
- Make sure to tighten both pedals securely to the pedal crank arms as instructed.
- Once proper seat and handlebar height is selected, make sure to tighten securely for a solid feel.

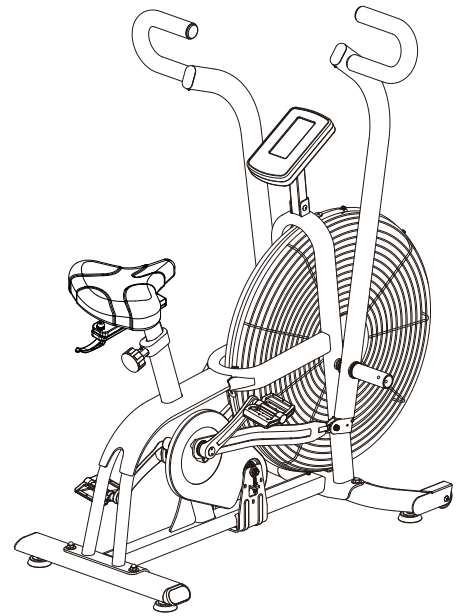

Adjusting The Bike For A Proper Fit

Take some time to learn how to properly adjust the bike to your body; it will make your workouts more pleasant and a safer experience too. Riding the bike when it is incorrectly adjusted can result in discomfort and increase your risk of injury.

Adjustment Of Seat Position

Seat Height Adjustment

1. Standing next to the bike, adjust the seat until it is about hip height.
2. Rotate the crank arms until the pedals are in the vertical position: 12 and 6 o'clock.
3. Place your foot in the toe cage of the pedal closest to the floor and mount the bike. Ensure that the ball of your foot is over the center of the pedal. Your leg should be slightly bent at the knee, about 5 degrees.
4. If your leg is too straight or your foot cannot touch the pedal you will need to lower the seat height. If your leg is bent too much, you will need to raise the seat height.
5. Dismount the bike. Then loosen the knob on the seat post and adjust up or down as necessary.
6. When the seat is in the desired position, tighten the quick release to secure the seat post.
7. Note the final position mark on the seat post for future reference.

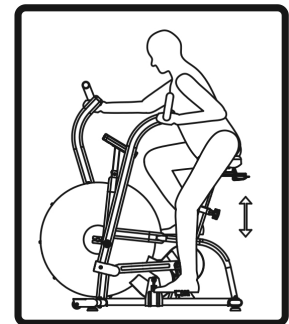

Seat Forward/Back Adjustment

8. Sit on the bike with the crank arms in the 3 and 9 o'clock positions. A proper forward/back position (for road bike training) of the seat is achieved when the small bump at the top of your shin is above the pedal axle.
9. Dismount the bike. Loosen the knob under the seat and slide the seat forward or backward as desired; tighten the knob.

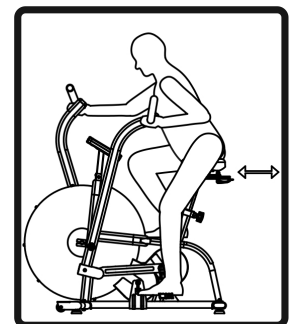

Exploring Your New Bike

Getting Familiar with the Control Panel

AIR650 Console

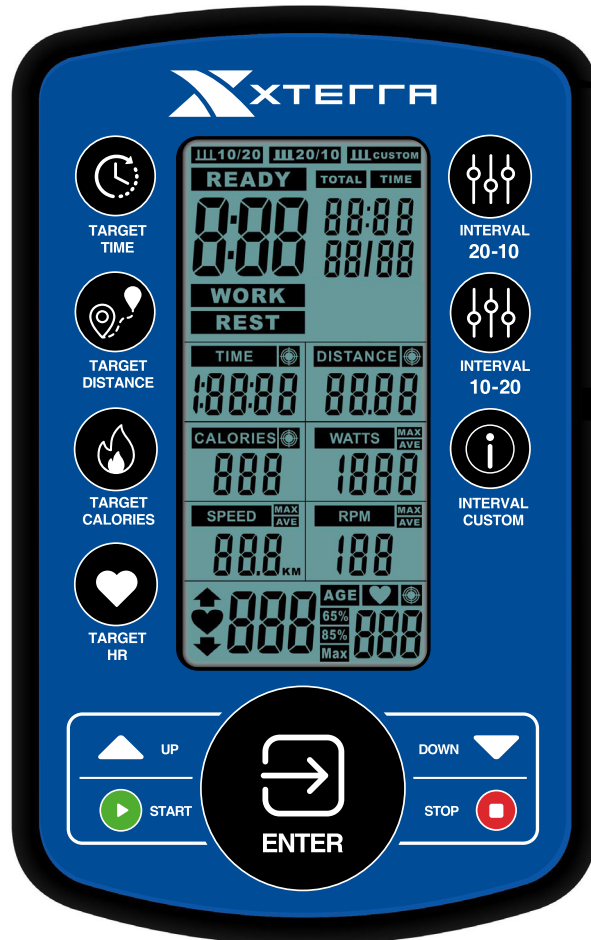

Program Selection

Your Airbike Pro offers several different program selections with different intensities and durations. In the next few pages you'll learn what each program entails so that you can select the program that is most appropriate for your workout that day. Selecting one of the 7 program buttons will immediately begin the set up of that program.

Button Functions

START - Press to begin a program selection, restart a paused program, or temporarily pause a ongoing program.

ENTER - Confirm values when making adjustments in a program mode.

STOP - Press to end a mode.

UP / DOWN ARROWS - increase or decrease program selection values.



Interval Display

The Interval Display Panel will show all details for the Interval 20/10, Interval 10/20, and Interval Custom mode.

The top-most blocks will tell which interval mode is operating.

This display will instruct whether the current operating interval is in WORK or REST period.

The TOTAL TIME will show the total run time while the large numeric display will show the WORK or REST segment time.

The 88/88 will show the current interval and the total number of intervals.

Target Time, Distance, & Calories Display

The Target Display Panel will show Time, Distance and Calories as operating mode. When target mode is in operation for a value, the target symbol will be active next to the value.

The TIME will alternately show the remaining or elapsed time.

The DISTANCE will countdown in miles or kilometers depending upon the initial console setup. See page 13.

The CALORIES will countdown the target number to zero.

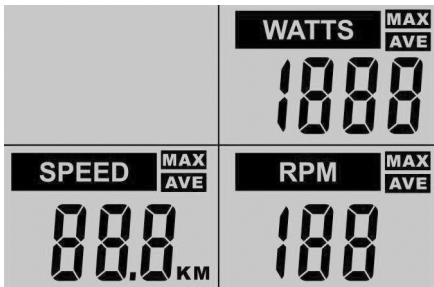
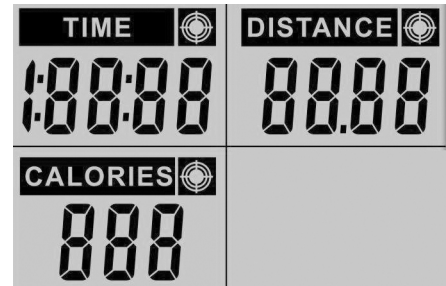

Watts, Speed, & RPM Display

Watts, Speed and RPM will be displayed during all modes.

The Watts value will vary throughout the workout, monitoring the amount of work produced.

The Speed will show a value which is derived from your current RPM or pedal speed. The value will show in miles or kilometers depending upon the initial console setup. See page 13.

RPM (revolutions-per-minute) is the number of pedal rotations per minute and varies at the cadence you pedal at.

Heart Rate Display (Chest Strap Not Included)

This section will show your heart rate information.

When console detects a signal from a wireless monitor, the BPM (beats-per-minute) will show in the large three-digit field and the heart icon will flash. However, if console does not detect any signal, it will show - - - in that field.

When the target heart rate mode is operating, the console assists you in maintaining a BPM range to build cardiovascular endurance. The target value range will be active on the right side of the panel.

The arrows will flash to tell that an increased or decreased pedal speed is needed to reach the desired range. When the user's heart rate is in the target range, the Target Heart Rate icon will be active.



Console Setup

Battery Installation

The console operates on 4*AA batteries (not included). The battery compartment is on the back side of the console.

Metric & Imperial Units - Setup

The manufacturer has already set the distance to display in Miles, but this can be changed for your preference.

In Ready Mode press and hold the START and ENTER keys for two (2) seconds until KM or M is flashing, pressing ▲ or ▼ to select metric (KM) or imperial (M) units, and then press ENTER to confirm.

Programming Features

Sleep Mode

After 60 seconds of inactivity, the console will go into the power-saving Sleep Mode. The display will switch off. Rotate the pedals or press any button on the console to launch the ready mode.

Ready Mode

The Ready Mode is to inform the user that the console is power on and ready to start a program. If a program is not selected or the pedals not touched, after 60 seconds the console will enter Sleep Mode.

Pause Mode

As any program is operating, pressing the START key will launch the Pause Mode for 5 minutes. The console will beep every 30 seconds to remind and the display will flash. If no any input is made in 5 minutes, the Pause Mode will end and console will revert back to the Ready Mode, ending the program selected.

To exit the Pause Mode and continue the currently running mode, press the START key. To quit the Pause Mode at any time, press the STOP key to launch the Ready Mode.

Reset Process

To reset all saved settings (except the metric or imperial units setting), press and hold the STOP for 2 seconds.

Workout Summary

The console provides a brief workout summary right after complete the workout. All data such as total time, total distance and total watts will be displayed.

Console Programs

Quick Start

The quick start option begins when you get on the bike and begin pedaling, no need to select a program. The console will show all data, including the your heart rate as long as the signal is detected. As the pedals stop moving, the mode will end. Pressing the STOP key also can end the mode and view the workout summary.

INTERVAL 20/10 & 10/20 MODE

The Interval programs provide a series of 8 workout intervals with preset time segments. This training method is known as Tabata® or (High Intensity Interval Training (H.I.I.T.)). The mode will inform the start of each Work - Rest interval.

20 / 10 - 20 second Work intervals, 10 second Rest intervals

10 / 20 - 10 second Work intervals, 20 second Rest intervals

Launch: Press the INTERVAL 10/20 or 20/10 button.

Start: A countdown from 3 will begin each interval

End: The program will end after the last interval. You can always end the program at any time by pressing the STOP key. A workout summary will be displayed.

INTERVAL CUSTOM MODE

The Custom Interval mode allows the you to set up the length of the Work / Rest intervals and the total amount of intervals.

Launch: Press the INTERVAL CUSTOM MODE button.

Setup: You will enter the total amount of intervals, and work/rest time interval.

Adjust the value by pressing ▲ or ▼ keys, then pressing the ENTER key to confirm for each setting.

Start: A countdown from 3 will begin each interval.

End: The program will end after the last interval. You can always end the program at any time by pressing the STOP key. A workout summary will be displayed.

TARGET TIME, DISTANCE & CALORIES

These TARGET programs operate in the same manner. You select which value you want to focus on and you set a goal as the target value.

Launch: Press any Target mode button

Setup: You will enter the target value of the selected program.

Adjust the value by pressing ▲ or ▼ keys, then pressing the ENTER key to confirm. If no particular value has been set, then the console will default to the most recent target value for each mode.

Start: The targeted field will be displayed and the target will count down (Time & Calories) or count up (Distance).

End: The program will end after the last interval. You can always end the program at any time by pressing the STOP key. A workout summary will be displayed.

TARGET HEART RATE (Chest Strap Not Included)

The TARGET HEART RATE program allows you to be able to set the BPM range for maximum cardiovascular training. This range will depend on your age and the program will calculate the maximum heart rate value as the optimized target (between 65% - 85% of maximum BPM). *Please note that this range is based on average values and your own health and weight may cause this range to be different from the pre-programmed values. Always speak with a trusted medical advisor to determine your personal BPM range.

Launch: Press Target Heart Rate button

Setup: You will be asked to enter your Age for reference. Adjust the value by pressing ▲ or ▼ keys, then press the ENTER buttons.

Start: The fields will display and begin to show progress. To direct you into the proper range, the arrow keys will display to direct you to work harder or work less.

End: The program will end as the user stops pedaling. You can always end the program at any time by pressing the STOP key. A workout summary will be displayed.

Heart Rate (Chest Strap Not Included)

The old motto, “no pain, no gain”, is a myth that has been overpowered by the benefits of exercising comfortably. A great deal of this success has been promoted by the use of heart rate monitors. With the proper use of a heart rate monitor, many people find that their usual choice of exercise intensity was either too high or too low and exercise is much more enjoyable by maintaining their heart rate in the desired benefit range.

To determine the benefit range in which you wish to train, you must first determine your predicted Maximum Heart Rate. This can be accomplished by using the following formula: 220 minus your age. This will give you the predicted Maximum Heart Rate (MHR) for someone of your age. To determine the effective heart rate range for specific goals you simply calculate a percentage of your MHR. Your heart rate training zone is 50% to 90% of your maximum heart rate. 60% of your MHR is the zone that burns fat, while 80% is for strengthening the cardiovascular system. This 60% to 80% is the zone to stay in for maximum benefit.

For someone who is 40 years old their predicted target heart rate zone is calculated:

$$220 - 40 = 180 \text{ (maximum heart rate)}$$

$$180 \times .6 = 108 \text{ beats per minute} \\ \text{(60\% of maximum)}$$

$$180 \times .8 = 144 \text{ beats per minute} \\ \text{(80\% of maximum)}$$

So for a 40 year old the training zone would be 108 to 144 beats per minute.

If you enter your age during programming the console will perform this calculation automatically. After calculating your MHR you can decide upon which goal you would like to pursue.

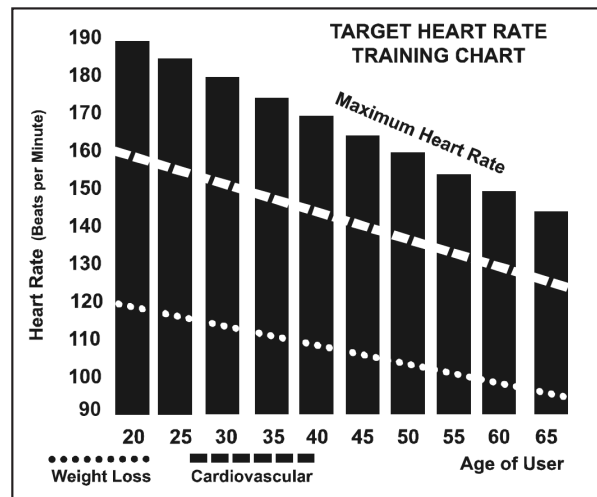

The two most popular reasons for, or goals, of exercise are cardiovascular fitness (training for the heart and lungs) and weight control. The black columns on the chart above represent the MHR for a person whose age is listed at the bottom of each column. The training heart rate, for either cardiovascular fitness or weight loss, is represented by two different lines that cut diagonally through the chart. A definition of the lines' goal is in the bottom left-hand corner of the chart. If your goal is cardiovascular fitness or if it is weight loss, it can be achieved by training at 80% or 60%, respectively, of your MHR on a schedule approved by your physician. Consult your physician before participating in any exercise program.

Rate of Perceived Exertion

Heart rate is important but listening to your body also has a lot of advantages. There are more variables involved in how hard you should workout than just heart rate. Your stress level, physical health, emotional health, temperature, humidity, the time of day, the last time you ate and what you ate all contribute to the intensity at which you should workout. If you listen to your body it will tell you all of these things.

The rate of perceived exertion (RPE), also known as the Borg scale, was developed by Swedish physiologist G.A.V. Borg. This scale rates exercise intensity from 6 to 20 depending upon how you feel or the perception of your effort.

The scale is as follows:

Rating Perception of Effort

- 6 Minimal
- 7 Very,very light
- 8 Very,very light +
- 9 Very light
- 10 Very light +
- 11 Fairly light
- 12 Comfortable
- 13 Somewhat hard
- 14 Somewhat hard +
- 15 Hard
- 16 Hard +
- 17 Very hard
- 18 Very hard +
- 19 Very,very hard
- 20 Maximal

You can get an approximate heart rate level for each rating by simply adding a zero to each rating. For example a rating of 12 will result in an approximate heart rate of 120 beats per minute. Your RPE will vary depending on the factors discussed earlier. If your body is strong and rested, you will feel strong and your pace will feel comfortable. When your body is in this condition, you are able to train harder and the RPE will support this. If you are feeling tired and sluggish, it is because your body needs a break. In this condition, your pace will feel difficult. Again, this will show up in your RPE and you will train at the proper level for that day.

Wearing the Chest Strap (Chest Strap Not Included)

1. Attach the transmitter to the elastic strap using the locking parts.
2. Adjust the strap as tightly as possible as long as the strap is not too tight to remain comfortable.
3. Position the transmitter with the logo centered in the middle of your torso facing away from your chest (some people must position the transmitter slightly left of center). Attach the final end of the elastic strap by inserting the round end and, using the locking parts, secure the transmitter and strap around your chest.
4. Position the transmitter directly below the pectoral muscles.
5. Sweat is the best conductor to measure very minute heart beat electrical signals. However, plain water can also be used to pre-wet the electrodes (2 ribbed oval areas on the reverse side of the belt and both sides of the transmitter). It's also recommended that you wear the transmitter strap a few minutes before your work out. Some users, because of body chemistry, have a more difficult time in achieving a strong, steady signal at the beginning. After "warming up", this problem lessens. As noted, wearing clothing over the transmitter/strap doesn't affect performance.
6. Your workout must be within range - distance between transmitter/receiver – to achieve a strong steady signal. The length of range may vary somewhat but generally stay close enough to the console to maintain good, strong, reliable readings. Wearing the transmitter directly on bare skin assures you of proper operation. If you wish, you may wear the transmitter over a shirt. To do so, wet the areas of the shirt that the electrodes will rest upon.

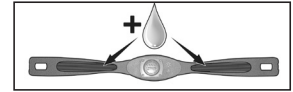
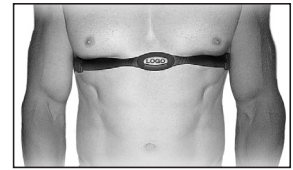

Note: The transmitter is automatically activated when it detects activity from the user's heart. Additionally, it automatically deactivates when it does not receive any activity. Although the transmitter is water resistant, moisture can have the effect of creating false signals, so you should take precautions to completely dry the transmitter after use to prolong battery life (estimated transmitter battery life is 2500 hours). The replacement battery is Panasonic CR2032.

Erratic Operation

Caution! Do not use this treadmill for Heart Rate programs unless a steady, solid Actual Heart Rate value is being displayed. High, wild, random numbers being displayed indicate a problem.

Areas to look for interference which may cause erratic heart rate:

1. Microwave ovens, TV's, small appliances, etc.
2. Fluorescent lights.
3. Some household security systems.
4. Perimeter fence for a pet.
5. Some people have problems with the transmitter picking up a signal from their skin. If you have problems try wearing the transmitter upside down. Normally the transmitter will be oriented so the XTERRA Fitness logo is right side up.
6. The antenna that picks up your heart rate is very sensitive. If there is an outside noise source, turning the whole machine 90 degrees may de-tune the interference.
7. Another Individual wearing a transmitter within 3' of your machine's console.

If you continue to experience problems contact XTERRA Fitness.

Manufacturer's Limited Warranty

Effective December 12, 2020 - AIR650 Airbike Pro LIMITED WARRANTY

XTERRA Fitness Inc. warrants all its home use Airbike Pro parts for a period of time listed below, from the date of retail sale, as determined by a sales receipt or in the absence of a sales receipt, eighteen (18) months from the original factory shipping date. XTERRA Fitness's responsibilities include providing new or remanufactured parts, at XTERRA Fitness's option, and technical support to our independent dealers and servicing organizations. In the absence of a dealer or service organization, these warranties will be administered by XTERRA Fitness directly to a consumer. The warranty period applies to the following components:

Home Use Limited WARRANTY

Frame	Parts	Labor
Lifetime	1 Year	1 Year

NORMAL RESPONSIBILITIES OF THE CONSUMER

This warranty applies only to products in ordinary household use. The consumer is responsible for the items listed below:

1. The warranty registration card must be completed and returned to the address listed on the card within 10 days of the original purchase to validate the manufacturer's limited warranty or register online at <http://www.xterrafitnessstore.com/warrantyreg.html>.
2. Proper use of the Airbike Pro in accordance with the instructions provided in this manual, including maintenance.
3. Proper connection to a power supply of sufficient voltage, replacement of blown fuses, repair of loose connections or defects in house/facility wiring.
4. Expenses for making the Airbike Pro accessible for servicing, including any item that was not part of the Airbike Pro at the time it was shipped from the factory.
5. Damages to the Airbike Pro finish during shipping, installation or following installation.

EXCLUSIONS

This warranty does not cover the following:

1. CONSEQUENTIAL, COLLATERAL, OR INCIDENTAL DAMAGES SUCH AS PROPERTY DAMAGE AND INCIDENTAL EXPENSES RESULTING FROM ANY BREACH OF THIS WRITTEN OR ANY IMPLIED WARRANTY. Note: Some states do not allow the exclusion or limitation of incidental or consequential damages, so this limitation or exclusion may not apply to you.
2. Service call reimbursement to the consumer. Service call reimbursement to the dealer that does not involve malfunction or defects in workmanship or material, for units that are beyond the warranty period, for units that are beyond the service call reimbursement period, for Airbike Pros not requiring component replacement, or Airbike Pros not in ordinary household use.
3. Damages caused by services performed by persons other than authorized XTERRA Fitness service companies, use of parts other than original XTERRA Fitness parts, or external causes such as alterations, modifications, abuse, misuse, accident, improper maintenance, inadequate power supply, or acts of God.
4. Products with original serial numbers that have been removed or altered.
5. Products that have been; sold, transferred, bartered, or given to a third party.
6. Products that are used as store display models.
7. Products that do not have a warranty registration on file at XTERRA Fitness, Inc. XTERRA Fitness reserves the right to request proof of purchase if no warranty record exists for the product.
8. Product use in any environment other than a residential setting.
9. THIS WARRANTY IS EXPRESSLY IN LIEU OF ALL OTHER WARRANTIES EXPRESSED OR IMPLIED, INCLUDING THE WARRANTIES OF MERCHANTABILITY AND/OR FITNESS FOR A PARTICULAR PURPOSE.

SERVICE

Keep your bill of sale. Twelve (12) months from the date on the bill of sale or eighteen (18) months from the date of factory shipping as determined by the serial number establishes the warranty period should service be required. If service is performed, it is in your best interest to obtain and keep all receipts. This written warranty gives you specific legal rights. You may also have other rights that vary from state to state. Service under this warranty must be obtained by following these steps, in order:

1. Contact your selling authorized XTERRA Fitness dealer. OR
2. Contact your local authorized XTERRA Fitness service organization.
3. If there is a question as to where to obtain service, contact our service department at (800) 258-8511.
4. XTERRA Fitness's obligation under this warranty is limited to repairing or replacing, at XTERRA Fitness's option, the product through one of our authorized service centers. All repairs must be preauthorized by XTERRA Fitness. If the product is shipped to a service center freight charges to and from the service center will be the customer's responsibility. For replacement parts shipped while the product is under warranty, the customer will be responsible for shipping and handling charges. For in-home service, the customer will be responsible for a trip charge. There will be an additional trip charge if the customer is located over 100 miles from the nearest service center.
5. The owner is responsible for adequate packaging upon return to XTERRA Fitness. XTERRA Fitness is not responsible for damages in shipping. Make all freight damage claims with the appropriate freight carrier. DO NOT SHIP ANY UNIT TO OUR FACTORY WITHOUT A RETURN AUTHORIZATION NUMBER. All units arriving without a return authorization number will be refused.
6. For any further information, or to contact our service department by mail, send your correspondence to:

XTERRA Fitness, Inc.
P.O. Box 2037
Jonesboro, AR 72402-2037

Product features or specifications as described or illustrated are subject to change without notice. All warranties are made by XTERRA Fitness, Inc. This warranty applies only in the 48 contiguous United States. NOTE: This does not apply to Alaska or Hawaii.

3000 Nestle Road Jonesboro, AR 72401 - Phone:870-336-4286 - Fax:870-935-7611

www.xterrafitness.com

©2020 All Rights Reserved. AIR650 Owner's Manual