

15 East Avenue Athens, TN
(800) 521-2855

bullbbq.com

Outdoor Rated Refrigerator

Owner's Manual

SKU# 21017



**USA
EDITION**



Important Safeguards

When using electrical appliances, basic safety precautions should always be followed including the following:

1. Read all instructions.
2. Plug into a grounded outlet, do not remove grounding prong, do not use an adapter, and do not use an extension cord.
3. Replace all panels before operating.
4. It is recommended that a separate circuit serving only your appliance be provided. Use receptacles that cannot be turned off by a switch or pull chain.
5. Never clean appliance parts with flammable fluids. These fumes can create a fire hazard or explosion. And do not store or use gasoline or other flammable vapours and liquids in the vicinity of this or any other appliance. The fumes can create a fire hazard or explosion.
6. Do not connect or disconnect the electric plug when your hands are wet.
7. Unplug the appliance or disconnect power before cleaning or servicing. Failure to do so can result in electrical shock or death.
8. Do not attempt to repair or replace any part of your appliance unless it is specifically recommended in this manual. All other services should be referred to a qualified technician.
9. Use two or more people to move and install this appliance. Failure to do so can result in back or other injury.
10. To ensure proper ventilation of this appliance, the front of the unit must be completely unobstructed.
11. Choose a well-ventilated area with temperatures above 50°F (10°C) and below 109.4°F (43°C).
12. The appliance should not be located next to ovens, grills or other sources of high heat.
13. It is important that the appliance be leveled in order to work properly. You may need to make several adjustments to level it.
14. All installations must be in accordance with local plumbing code requirements. Make certain that the pipes are not pinched, kinked, or damaged during installation. Check for leaks after connection.
15. Never allow children to operate, play with or crawl inside the appliance.
16. Do not use solvent-based cleaning agents or abrasives on the interior. These cleaners may damage or discolor the interior.
17. Use this appliance only for its intended purpose as described in this Instruction Manual.
18. Keep fingers out of the "pinch point" areas. Clearances between the door and cabinet are small by necessity.
19. Be careful closing door when children are in the area.
20. Save these instructions.

 **WARNING:** This product may expose you to chemicals including lead which is known to the State of California to cause birth defects or other reproductive harm.
For more information, visit: www.P65Warnings.ca.gov

 **WARNING:** Child entrapment and suffocation are not problems of the past. Junked or abandoned appliances are still dangerous, even if they will "just sit for a few days". Before discarding your old refrigerator, take off the doors and leave shelves in place so that children may not easily climb inside.

IMPORTANT: This appliance utilizes an external electrical source; therefore, this appliance, when installed, must be electrically grounded in accordance with local codes. In the absence of local codes, this appliance must be electrically grounded in accordance with one of the following:

- NFPA 70
- Canadian Electrical Code, Part 1

We care about your safety, so please...

Read and follow all warnings and instructions before assembling and using your refrigerator.

Retain this manual for future reference.

Table of Contents

<i>Installation Instructions</i>	4
<i>Door Hinge Reversal</i>	5
<i>Operating Instructions</i>	11
<i>Cleaning and Maintenance</i>	12
<i>Troubleshooting</i>	15
<i>Product Warranty and Registration</i>	16
<i>Replacement Parts List</i>	17
<i>Warranty Policy</i>	18

Service Information

Model Number:

21017

Serial Number: _____

Date of Purchase: _____

Place of Purchase: _____

Installation Instructions

Locating your appliance:

- This appliance is designed and intended for built-in recessed or free-standing installation applications only.
- Place your appliance on a floor that is strong enough to support it when fully loaded.
- Ensure that your appliance is level, there are two adjustable legs on the front of the appliance to assist in leveling the appliance.
- Ensure that the air vent located on the front of the appliance is never covered or blocked in anyway.
- It is recommended that you do not install this appliance near an oven, radiator, or other heating source. Doing so will result in increased energy consumption.
- Do not install in a location that falls below 50°F (10°C).
- For best performance, do not install the appliance behind a cabinet door or block the base of the grill.
- Avoid locating the appliance in moist areas.

Before first use:

1. Remove the exterior and interior packing.
2. Allow the appliance to stand upright for a minimum of 24 hours. This will reduce the possibility of a malfunction in the cooling system from shipping/handling.
3. Clean the interior surface with lukewarm water using a soft cloth.
4. Install the handle on the door if it is not already attached.
5. Insert shelf supports into the racks at the desired locations as shown in the image below. There are three wire racks that will require six total shelf supports.
6. With supports installed, simply slide in the shelves and allow them to rest on the supports.

IMPORTANT: Ensure the door is fully open when installing the shelves, and take great care not to damage the door gasket with the shelves.

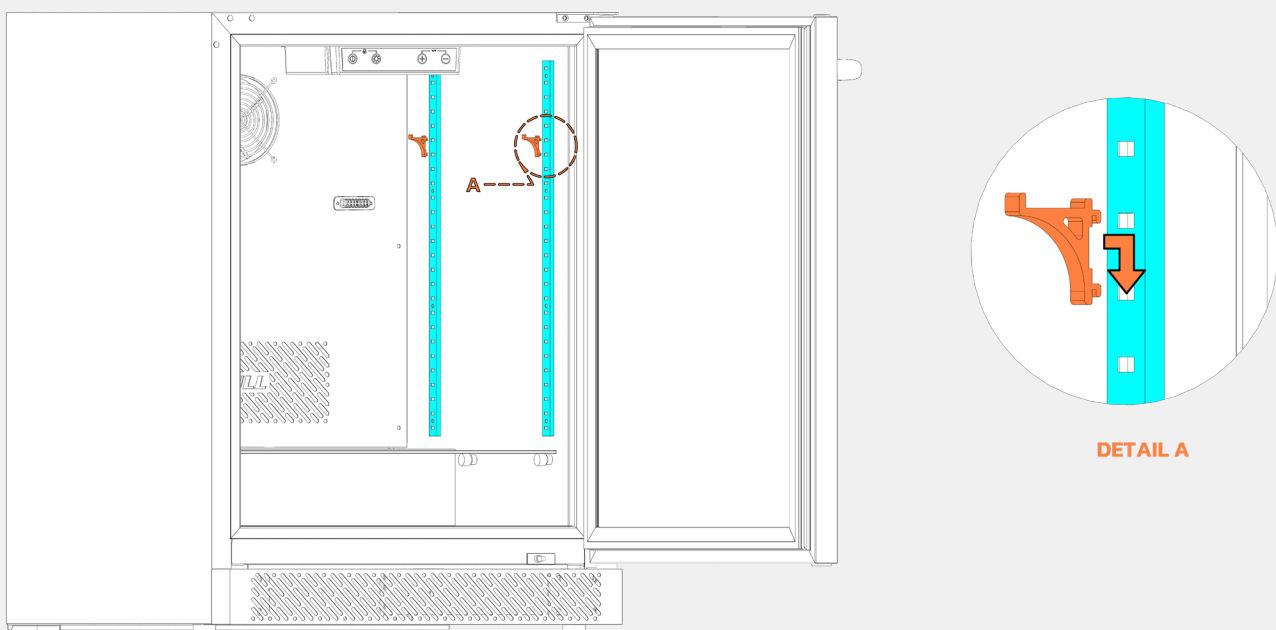

Door Hinge Reversal

Door Hinge Configurations:

- The appliance door can be configured to open on either the left or right side. By default, the appliance is shipped with the hinge on the right.

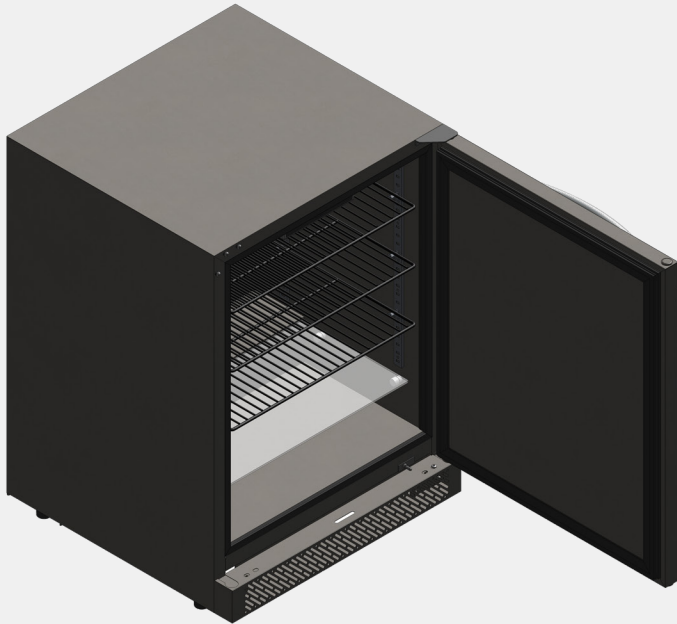

Default Door Configuration (RH Hinge)

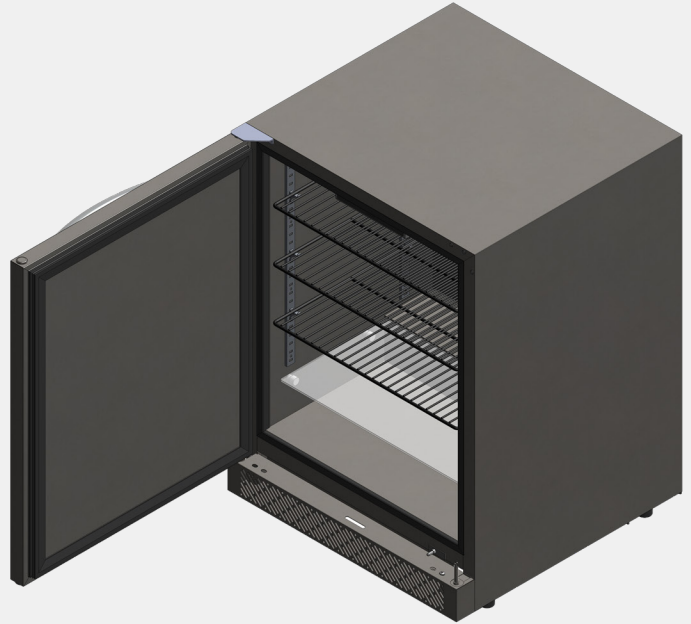

Optional Door Configuration (LH Hinge)

Door Hinge Conversion:

Before continuing, unplug the unit from its electrical source! Then, to swap the hinge arrangement, follow the following process.

1. With the door open, remove all the shelves from inside the appliance.
2. With the door still open, remove the two screws located on top of the kick plate as shown.

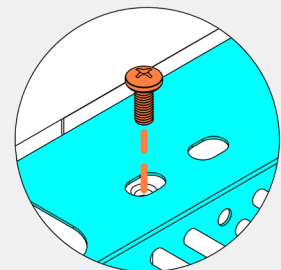
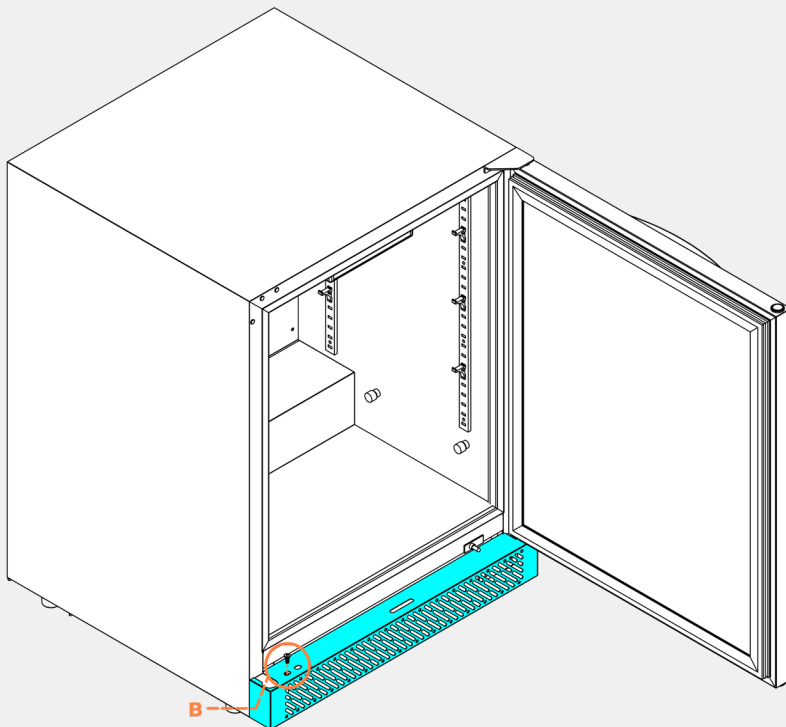

DETAIL B

3. Close the door and carefully rotate the appliance to lay it on the ground.
4. With the back of the appliance on the ground, the bottom two screws on the kick plate can be removed as shown.
5. With the remaining screws removed, the kick plate can be set aside.

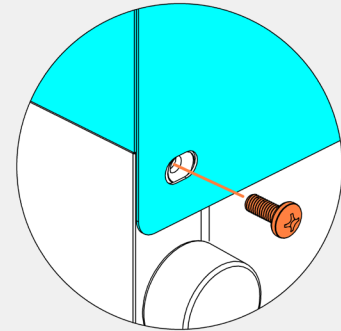
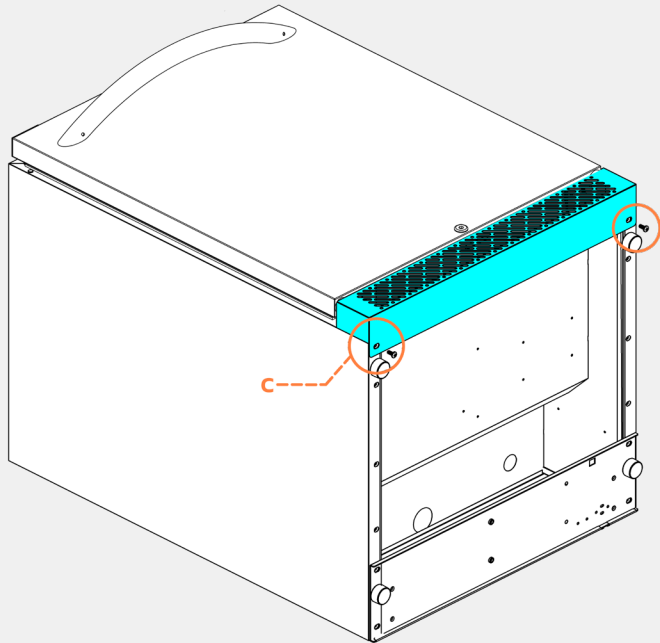

DETAIL C

6. Remove the two bottom brackets that are now exposed with the kick plate removed. Each bracket is fastened to the appliance via two Phillips head screws.

CAUTION:

The bracket on the right-hand side (hinge side) is under spring tension. Take care when removing.

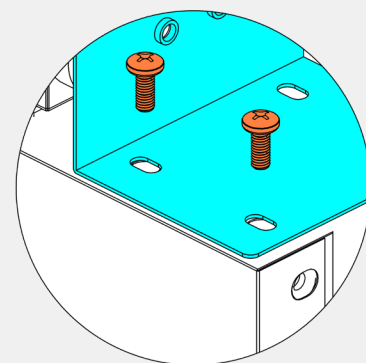
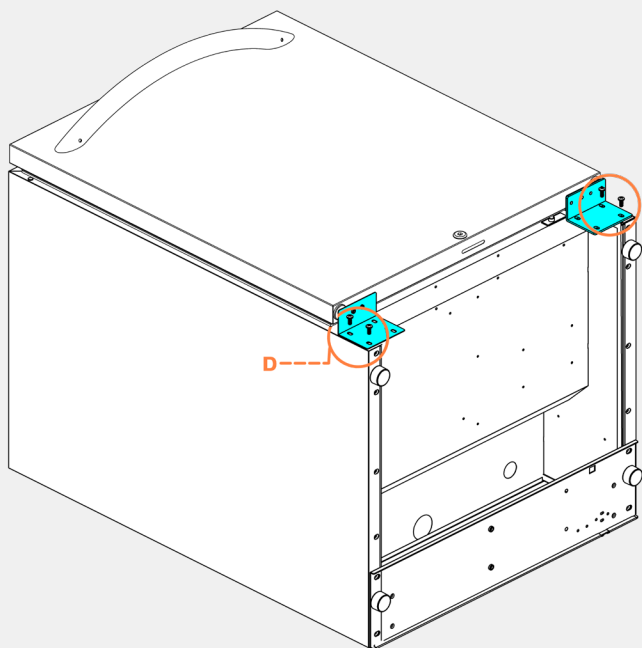

DETAIL D

7. Slide the door off the top hinge in the direction shown below now that the two bottom brackets are removed.

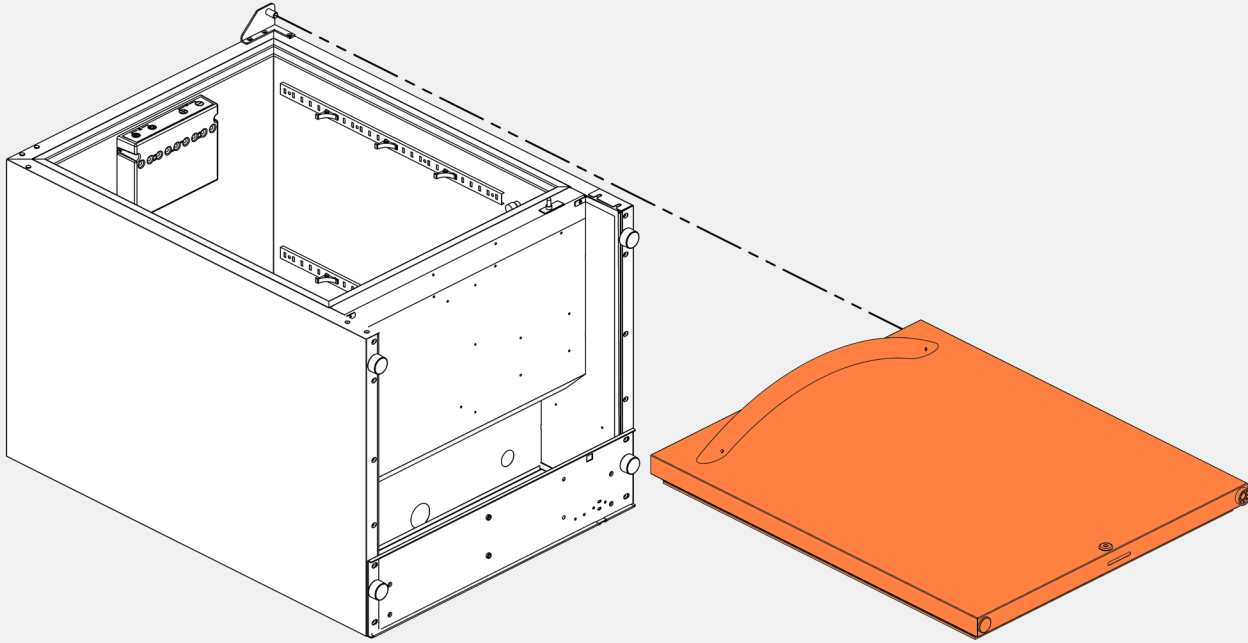

8. Remove the top-right hinge bracket. It is secured to the appliance via three Phillips head screws.
9. In the top-left corner, there are three decorative hole plugs. Remove all three plugs, as this is where the left hinge bracket will be located.
10. Use the three decorative hole plugs to cover up the holes in the top-right corner now that the right hinge bracket has been removed.

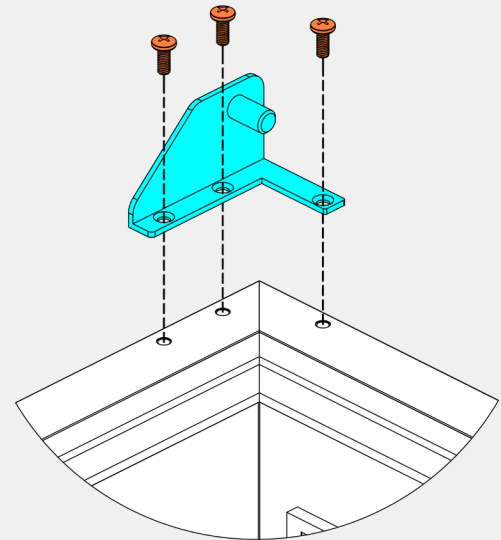
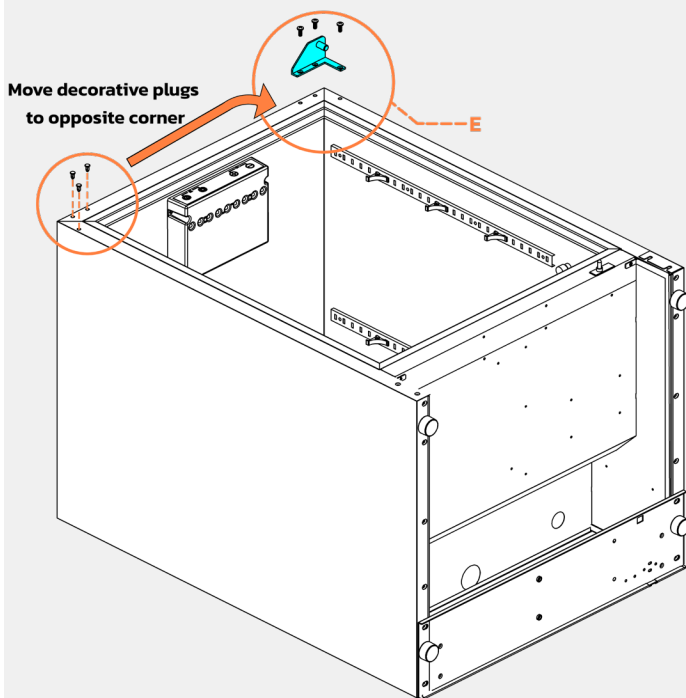

DETAIL E

11. Locate the left hinge bracket supplied with the appliance and fasten it to the frame with the three screws removed from step 8. This is not the same bracket removed in the previous steps, so ensure you have the correct bracket!

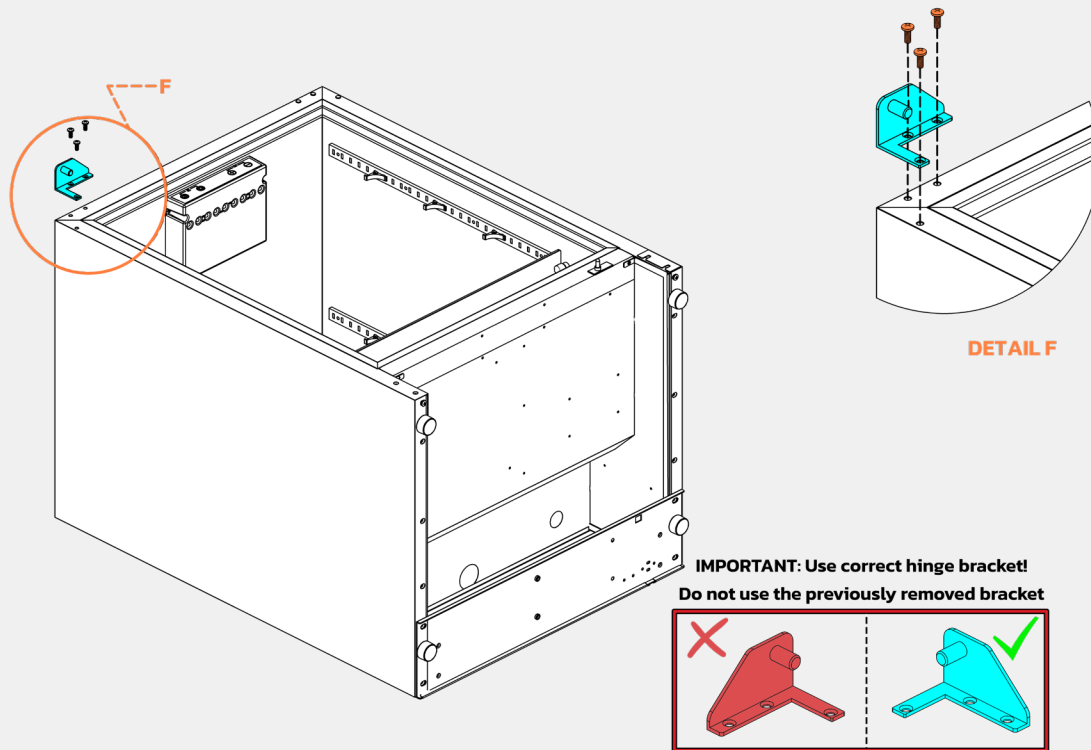

12. Now we turn our attention to the door. From the top end of the door, remove the decorative plug located in the top left corner. Use this plug and insert it into the top right hole of the door as shown below.
13. At the bottom of the door, remove the decorative plug on the bottom left hole.
14. Remove the white-colored tension plug and bearing washer located on the bottom right hole.
15. Insert the decorative plug into the bottom right hole where the tension plug was previously.
16. Grab the black tension plug provided inside the appliance and bearing washer and insert into the bottom left hole.

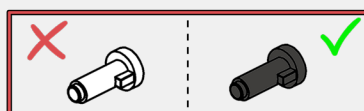
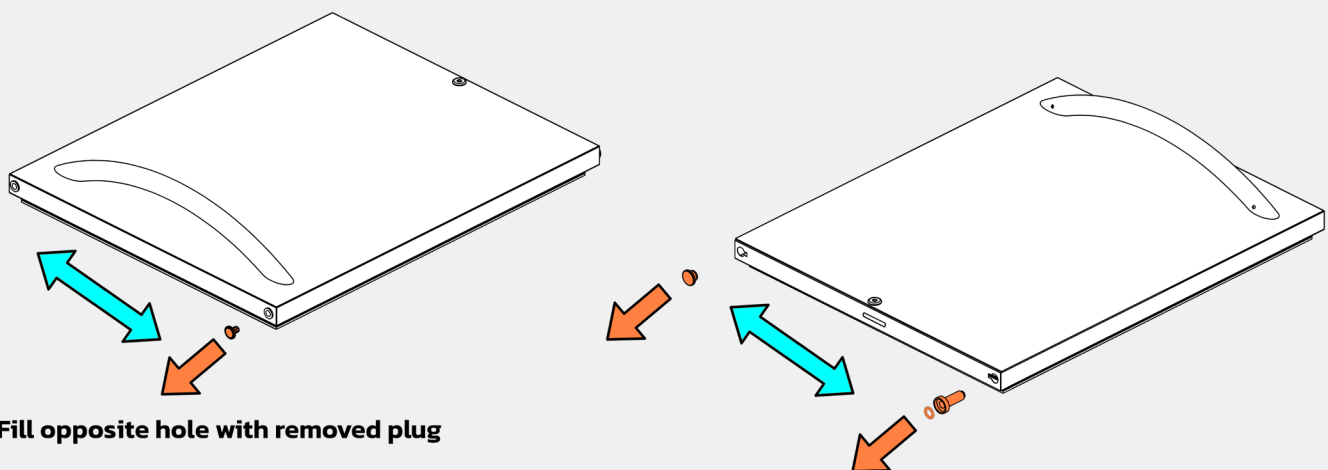

Fill opposite hole with removed plug.
Replace the white tension plug with the black tension plug and install in opposite hole

17. Slide the converted door up into the left hinge bracket.

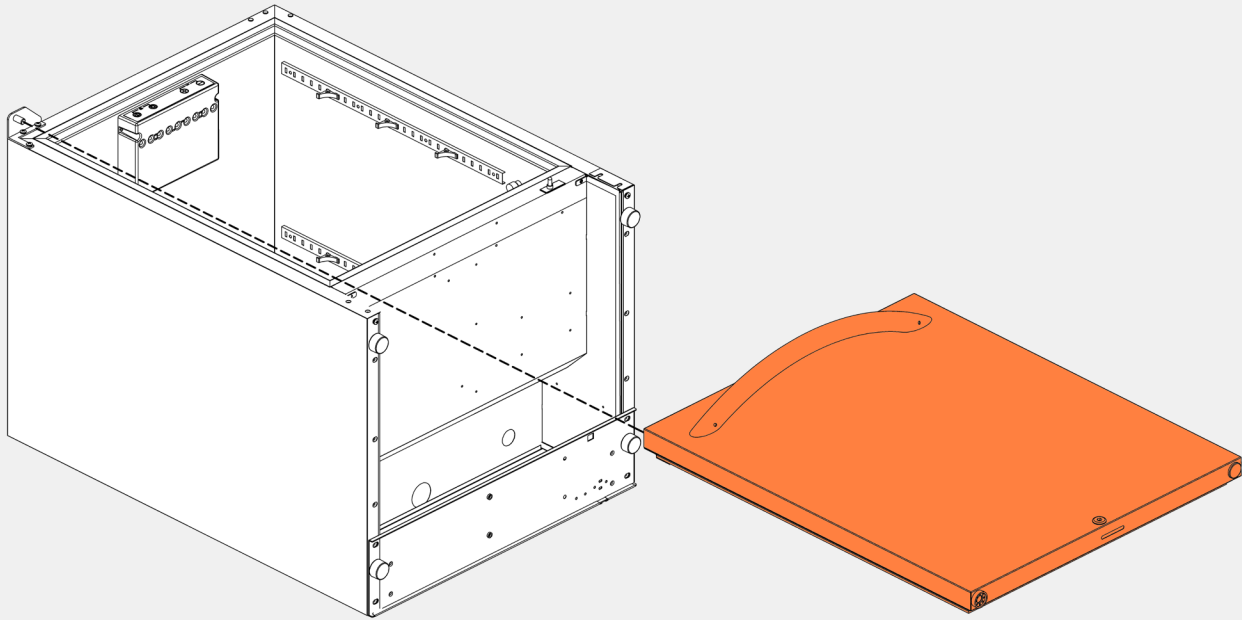

18. Take the bracket that was previously on the bottom right of the appliance and remove the two screws holding the pivot pin onto this bracket. Rotate the pivot pin 180° and fasten the pivot pin back onto the bracket as shown below.

19. Install the bottom two brackets in the orientation shown below. The green bracket will need to be rotated roughly 90° to fully insert and engage with the spring plug. Secure each bracket to the appliance frame with two screws removed in the previous step (four screws total).

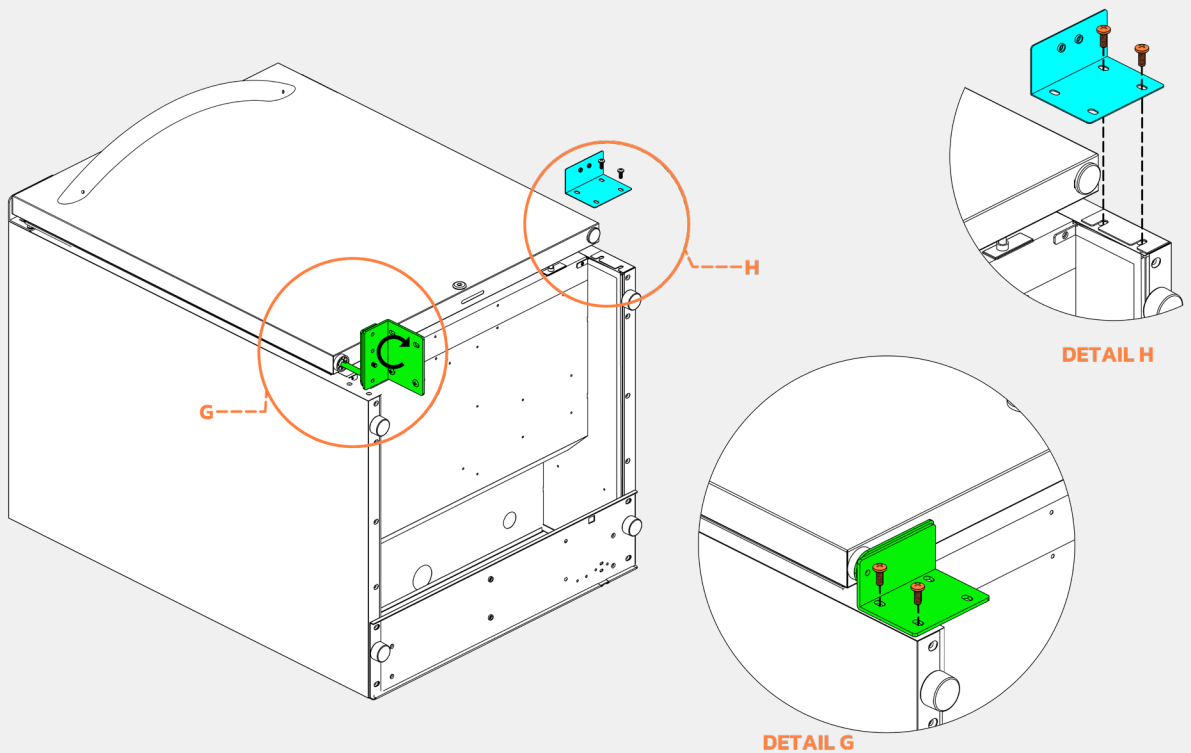
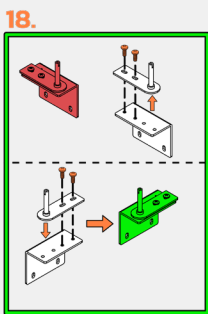

20. Re-install the kick plate and secure it to the frame with the two screws removed earlier.

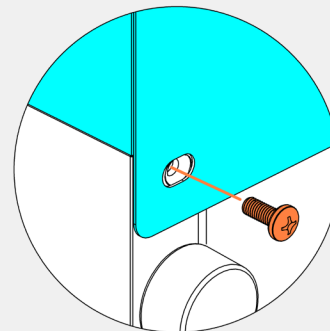
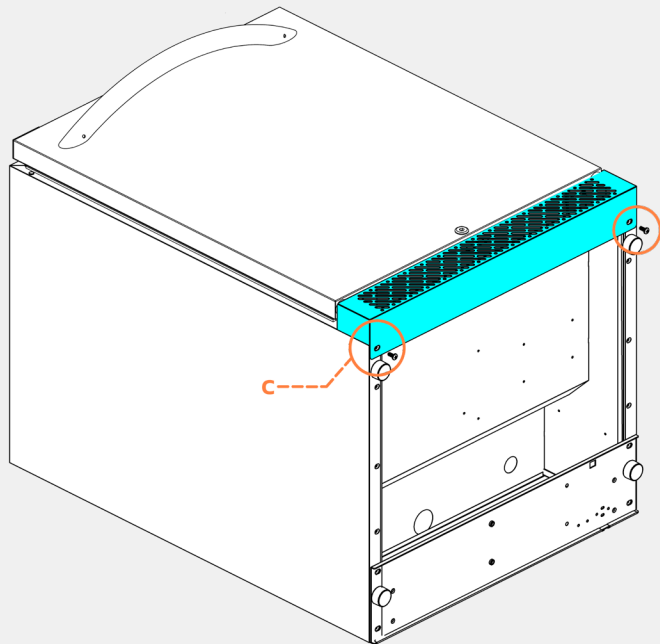

DETAIL C

21. Rotate the appliance back upright.

22. Test the swing of the door to be sure it closes on its own.

23. Re-install the last remaining screw on the kick plate.

24. Replace the shelves and wait an hour before plugging the unit back in to the electrical source.

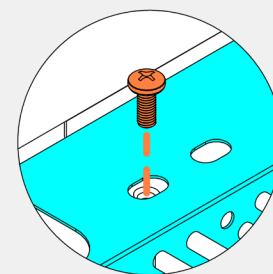
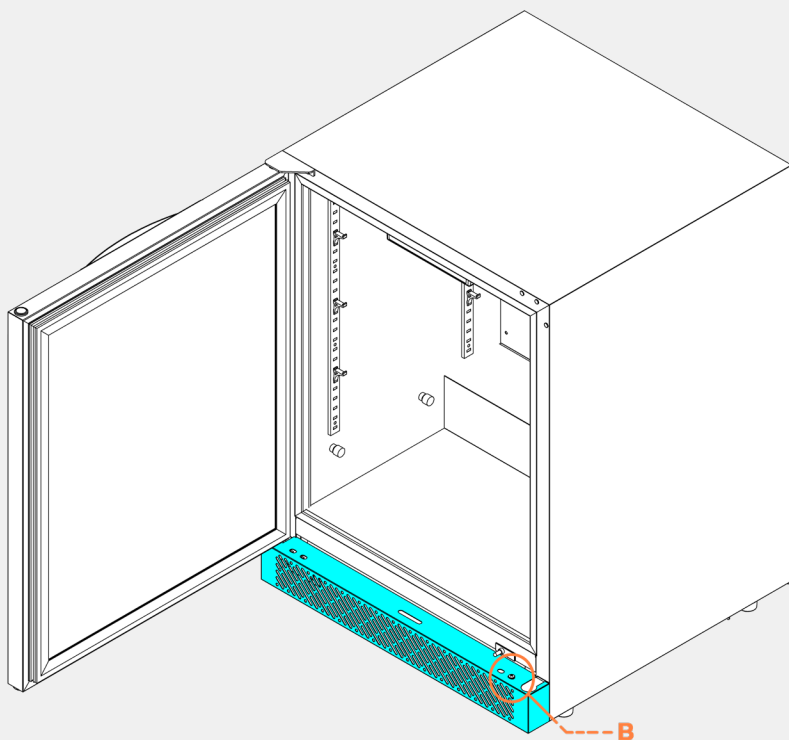

DETAIL B

Operating Instructions

The display for your appliance's control panel is shown below along with button functions.

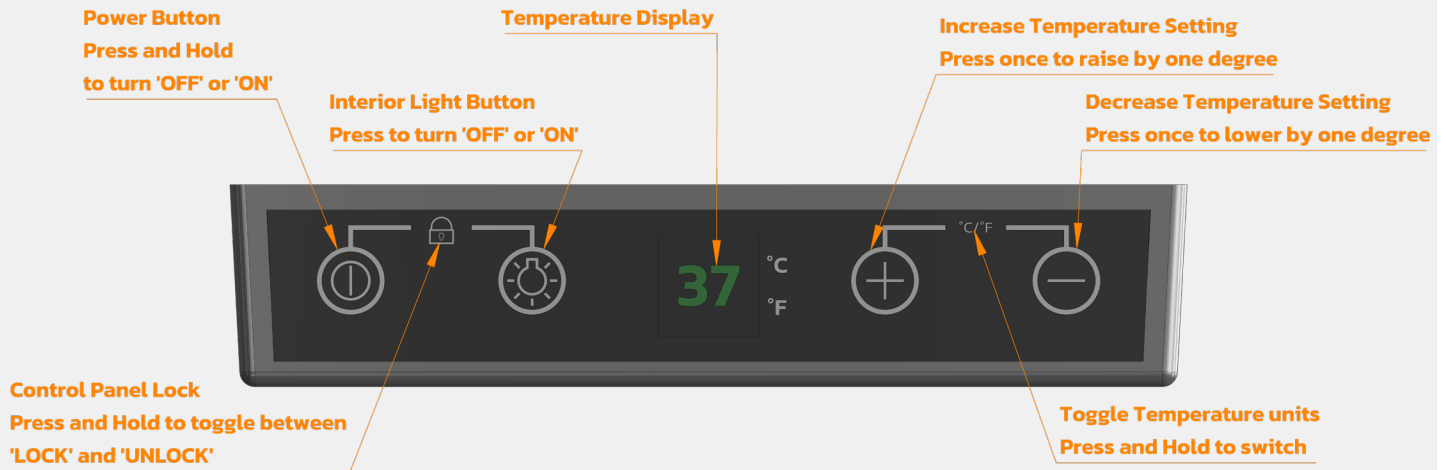

Interior Light:

The appliance is equipped with an interior LED light that turns ON when the door is open. Opening the door automatically shuts off the interior fan at the same time. You can press the button with light symbol on the digital control panel to manually turn the light off or on.

Defrosting:

The unit defrosts automatically in normal operating conditions. The evaporator behind the rear wall of the unit defrosts automatically. The resulting condensation is collected in the drainage channel behind the rear wall of the unit and flows through the drainage hole into the drip tray by the compressor where it evaporates.

IMPORTANT: if the door is opened in a high heat or high humidity location it may cause frost to accumulate on the evaporator. If the frost pattern does not clear within 24 hours, your unit will require manual defrosting.

To initiate a manual defrosting cycle, press and hold the power button for six seconds. Once defrosting is complete, press and hold the same button again for six seconds to turn off defrost mode.

Door Alarm:

If the door is left open for more than 60 seconds, an audible alarm will sound. Pressing any button once will turn off the alarm.

Door Lock:

The door of your unit has a lock and key provided. These should be in the plastic bag containing the owner's manual. To lock the door, insert the key in the door's lock (make sure the pin for the lock is engaged) and turn it clockwise. Turn the key counter clockwise to unlock the door. When not in use store the key in a secure location for safe keeping.

Cleaning and Maintenance

1. Turn off the appliance. Unplug the power cord and remove all items including the shelves.
2. Wash the inside surfaces with a solution of warm water and baking soda (about 2 tablespoons of baking soda per 1 gallon of water).
3. Wash the shelves with a mild detergent solution.
4. Wring out excess water from sponge or cleaning cloth before cleaning around control panel display, or electrical parts.
5. Wash the outside of the unit with a solution of warm water and mild detergent. Rinse well and dry with a clean, soft cloth towel.
6. When cleaning the outside of the unit be sure to use cleansers that are designated for stainless steel. Do not use steel wool scrubbing pads or a wire brush.

Power Failure:

Your refrigerator will maintain its temperature for a few hours if the door is kept closed in the event of a power failure. If the power failure continues, you will need to remove the contents that are at risk.

Vacation Periods (or prolonged periods of non-use):

Short Vacations (Less than 3 weeks): leave the unit on.

Long Vacations (Longer than 3 weeks): Remove the contents, unplug the unit and follow the cleaning instructions for interior and exterior.

Note: Odors or Mold growth can be avoided by blocking the door from fully closing, but with care not to harm the door gasket.

Moving the Appliance:

1. Remove all items.
2. Remove the shelves or use tape to secure them in place.
3. Turn the adjustable feet clockwise until they are all the way in to avoid damaging them.
4. Tape the door shut.
5. Use moving blankets or equivalent to protect the outside while moving.
6. Always keep the unit in the upright position, never place on its side or upside down.

Energy Saving Tips:

- The appliance should be located in the coolest area of the room or outdoor location, away from heat producing appliance and out of direct sunlight.
- Ensure the unit is adequately ventilated. Never cover air vents.
- Do not keep the door open any longer than necessary.
- Let hot foods cool to room temperature before placing in the unit. Overloading the unit forces the compressor to run longer.
- Be sure to wrap foods properly, and wipe containers dry before placing them in unit. This cuts down on frost build up inside the unit.
- Unit shelves and storage bins should not be lined with aluminum foil, wax paper or paper towels. These liners interfere with air circulation resulting in less operating efficiency.
- Organize and label stored items to reduce door opening or extended searching for items.
- Remove as many items as needed while avoiding opening door repeatedly. Always close door as soon as possible.

Appliance Disposal:

Before disposing of the appliance, disconnect the unit from the electrical source. With the appliance disconnected from the power source, cut off the main cable and discard it.

To prevent possible harm to the environment or human health from uncontrolled waste disposal, recycle it responsibly to promote the sustainable reuse of material resources. To return your used device, please use the return and collection systems or contact the retailer where the product was purchased. They can take this product for environmental safety.

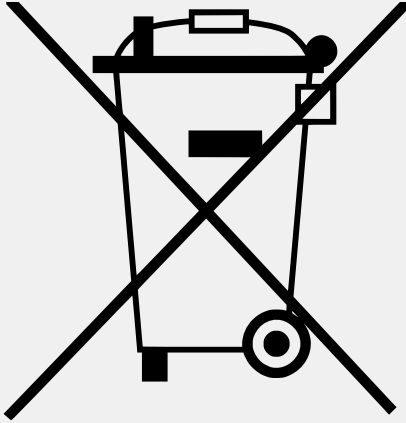

This symbol on the product, or in its packaging, indicates that this product may not be treated as household waste. Instead, it should be taken to the appropriate waste collection point for the recycling of electrical and electronic equipment. By ensuring this product is disposed of correctly, you will help prevent potential negative consequences for the environment and human health, which could otherwise be caused by the inappropriate waste handling of this product. For more detailed information about the recycling of this product, please contact your local council, your household waste disposal service, or the shop where you purchased the product.

Door Switch Replacement:

If a replacement door switch is required, please use the image below to help identify the correct switch for your appliance. Depending on when your appliance was manufactured, you will either need a switch with two prongs (SKU# 10055) or you will need a switch with three prongs (SKU# 13735)

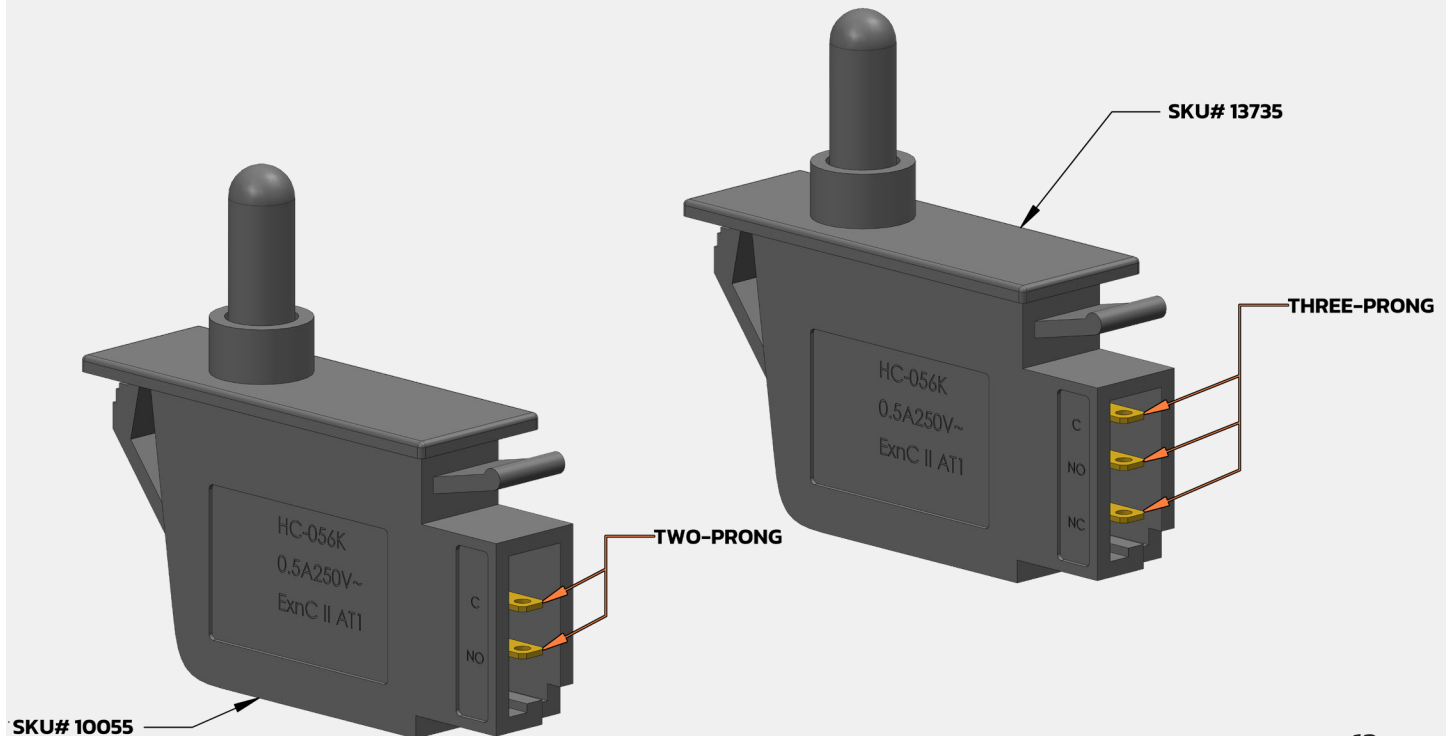

Door Handle Replacement:

If a replacement door handle or handle hardware is required, please use the image below to help identify the correct hardware for your appliance.

Appliances manufactured before June 2025:

- Two long flat head screws are required

Appliances manufactured after June 2025:

- Two dowel screws and two set screws are required.

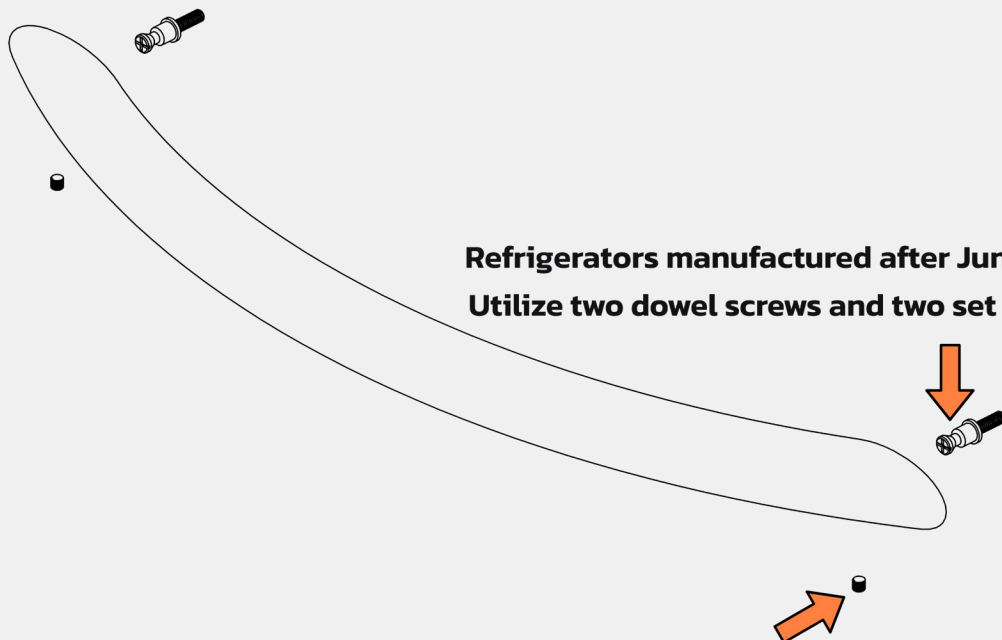
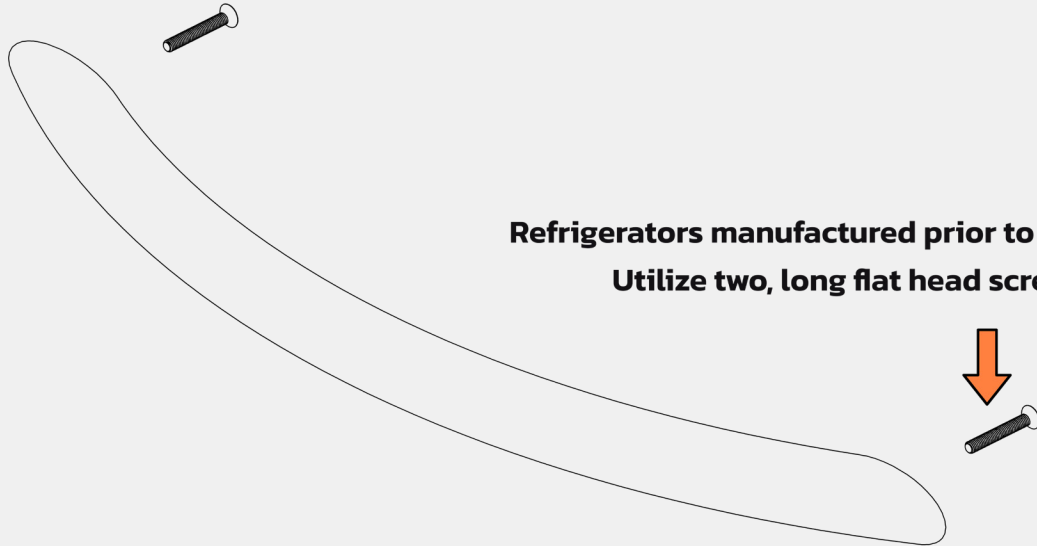

Troubleshooting

If you've checked the table below and find that you still need help with your appliance call our Customer Service Facility at 1800-521-2855 or <https://bullbbq.com/contact/> We will do our best to answer your questions.

Problem	Possible Cause	Remedy
Appliance does not operate	<ol style="list-style-type: none"> 1. The appliance is turned off. 2. The appliance is not connected to a power supply. 3. Tripped circuit breaker or blown fuse. 	<ol style="list-style-type: none"> 1. Turn on the appliance. 2. Connect the appliance. 3. Reset breaker or replace fuse.
Appliance is not cold enough	<ol style="list-style-type: none"> 1. The temperature not set correctly. 2. The ambient temperature could require a lower setting. 3. The door was opened too often. 4. The door was not completely closed. 5. Door is not hermetically sealed. 6. The condenser is too dirty. 7. The ventilation opening is blocked or dusty. 	<ol style="list-style-type: none"> 1. Check the set temperature. 2. Change the setting to a lower temperature. 3. Close the door properly. 4. Check the door seal and clean or replace. 5. Clean the condenser as necessary. 6. Clear the obstructions and dust.
Appliance turns itself on or off frequently	<ol style="list-style-type: none"> 1. The ambient temperature is higher than average. 2. A large amount of food has been added to the unit. 3. The door is open too often. 4. The door is not closed completely. 5. The door gasket does not seal properly. 	<ol style="list-style-type: none"> 1. Locate the appliance in a colder location. 2. Leave the appliance closed until the set temperature has been reached. 3. Do not open the door more than necessary. 4. Close the door properly. 5. Check the door seal and clean or replace.
The interior light does not work	<ol style="list-style-type: none"> 1. The light was switched off on the control panel. 2. The appliance is not connected to a power supply. 3. Tripped circuit breaker or blown fuse. 	<ol style="list-style-type: none"> 1. Switch on the light. 2. Connect the appliance. 3. Reset the circuit breaker or replace fuse.
Excessive Vibration	<ol style="list-style-type: none"> 1. The appliance is not properly leveled. 	<ol style="list-style-type: none"> 1. Level the appliance with the adjustable feet.
The appliance seems to make too much noise*	<ol style="list-style-type: none"> 1. The appliance is not properly leveled. 	<ol style="list-style-type: none"> 1. Level the appliance with the adjustable feet.
The door will not close	<ol style="list-style-type: none"> 1. The appliance is not properly leveled. 2. The door was reversed and not properly installed. 3. The door gasket is dirty. 4. The shelves are out of position. 	<ol style="list-style-type: none"> 1. Level the appliance with the adjustable feet. 2. Check the door hinge and reassemble correctly. 3. Clean the door gasket. 4. Check the shelves and install correctly.
The alarm sounds and the temperature display flashes	<ol style="list-style-type: none"> 1. Door has been open longer than 60 seconds. 2. The appliance door being opened too often. 3. The ventilation openings are covered or too dirty. 4. A lengthy interruption in the power supply. 5. A large amount of food has been added to the unit. 	<ol style="list-style-type: none"> 1. Properly close the door. 2. Do not open the door more than necessary. 3. Clear the obstructions and clean the dust. 4. Leave the appliance to work for a while until the set temperature is reached. 5. Leave the appliance to work for a while until the set temperature is reached.

* A rattling noise may come from the flow of refrigerant. This is normal and no cause for alarm. As the cycle ends, you may hear gurgling sounds caused by the flow of refrigerant in the appliance. If temperature fluctuations occur, the contraction and expansion of the inner walls which may cause popping and cracking noises.

Product Warranty and Registration

Thank you for choosing Bull Outdoor Products. To enable our commitment to your satisfaction, you will need to register your purchase for it to be covered under Bull's warranty policy. Please save your purchase receipt as it is required for warranty claims. Additionally, registering your purchase will allow Bull or your Bull Authorized Dealer to utilize the encoded information for the purpose of ordering replacement parts or additional accessories to ensure your purchase remains in optimal working condition. To validate your warranty, we offer two options as shown below:

Option 1: Online Registration

 Registration can be completed on the Bull Customer Service Portal

 Scan the QR code, or visit: <https://api.bullbbq.com/c/>

Option 2: Mail-in Registration

Complete the Product Warranty Registration Card located in the shipping box. A reference of the card is shown to the right.

Mail the completed card to:

BULL OUTDOOR PRODUCTS, INC.
15 East Ave, Athens, TN
Attn: Warranty Service Center



Bull Outdoor Products Warranty Registration Card 

Name _____ Date of Purchase _____

Place of Purchase _____ Phone _____

Email Address _____ Apt # _____

Street Address _____

City _____ State _____ Zip Code _____

How To Register
On Our Website: Bullbbq.ladesk.com/submit_ticket
Via Mail: Fill out this form and mail it to us!

Model Name: _____

Model Number: _____

Serial Number: _____

Scan This Code With Your Phone 

Unpacking the Refrigerator:

After opening the box, carefully inspect the contents for any damage. Contact our service center or local dealer for replacement of any damaged/missing parts. If damaged, do not attempt to install.

Ordering Replacement Parts:

Please refer to your owner's manual parts list and illustration(s) to identify what you need. Have your serial number ready. Replacement parts can be purchased via two options.

Option 1: Online

 Scan the QR code, or visit:
<https://bullbbq.com/buy-parts>

Option 2: Phone

We have two authorized parts distributors ready to assist.

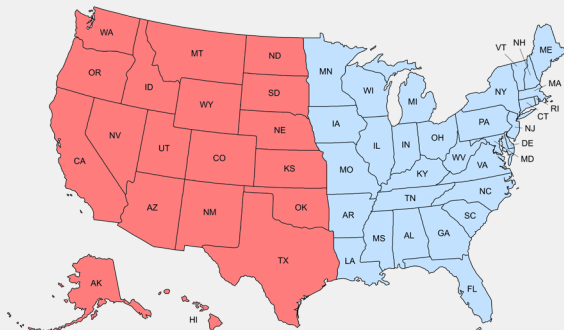

Western Region
(800) 258-6810

Eastern Region
(800) 229-3056

Serial Number Locations:

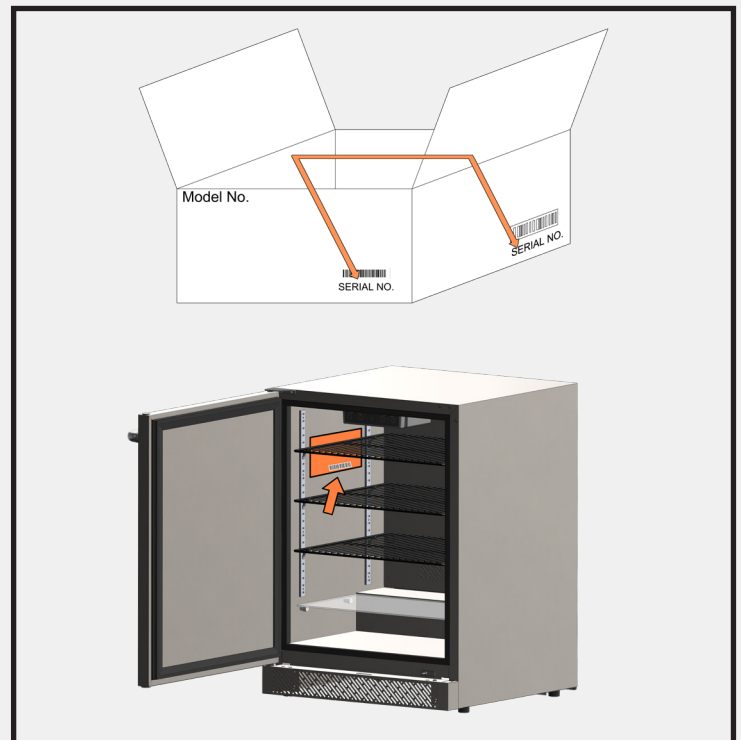

Replacement Parts List

ITEM NUMBER	BULL SKU#	DESCRIPTION	QTY
1	13726	LOWER DOOR HINGE	1
2	13727	LOWER DOOR KICK PLATE BRACKET	1
3	13713	KICK PLATE (MODELS O2-2024 AND OLDER)	1
	13103	KICK PLATE (MODELS O3-2024 AND NEWER)	
4	13730	AUTOMATIC DOOR CLOSING HINGE (LEFT, BLACK)	1
5	13731	AUTOMATIC DOOR CLOSING HINGE (RIGHT, WHITE)	1
6	13709	TOP RIGHT HINGE BRACKET	1
7	13710	DOOR GASKET	1
8	21157	UI DOOR EMBLEM	1
9	98723NS	BULLET DOOR EMBLEM	1
10	13720	DOOR HANDLE	1
11	13703	CONTROL PANEL (MODELS O2-2024 AND OLDER)	1
	12103	CONTROL PANEL (MODELS O3-2024 AND NEWER)	
12	13708	GLASS SHELF	1
13	13707	WIRE SHELF	3
14	13704	SHELF BRACKET	12
15	13706	SHELF RAIL	4
16	13729	TEMPERATURE SENSING HEAD COVER	1
17	13728	EVAPORATOR FAN COVER	1
18	13701	EVAPORATOR FAN	1
19	13715	COMPRESSOR REAR GUARD (MODELS O2-2024 AND OLDER)	1
	13734	COMPRESSOR REAR GUARD (MODELS O3-2024 AND NEWER)	
20	13716	CONDENSER FAN	1
21	13714	LEVELING FEET	4
22	13735	THREE-PRONG DOOR SWITCH	1
	10055	TWO-PRONG DOOR SWITCH	

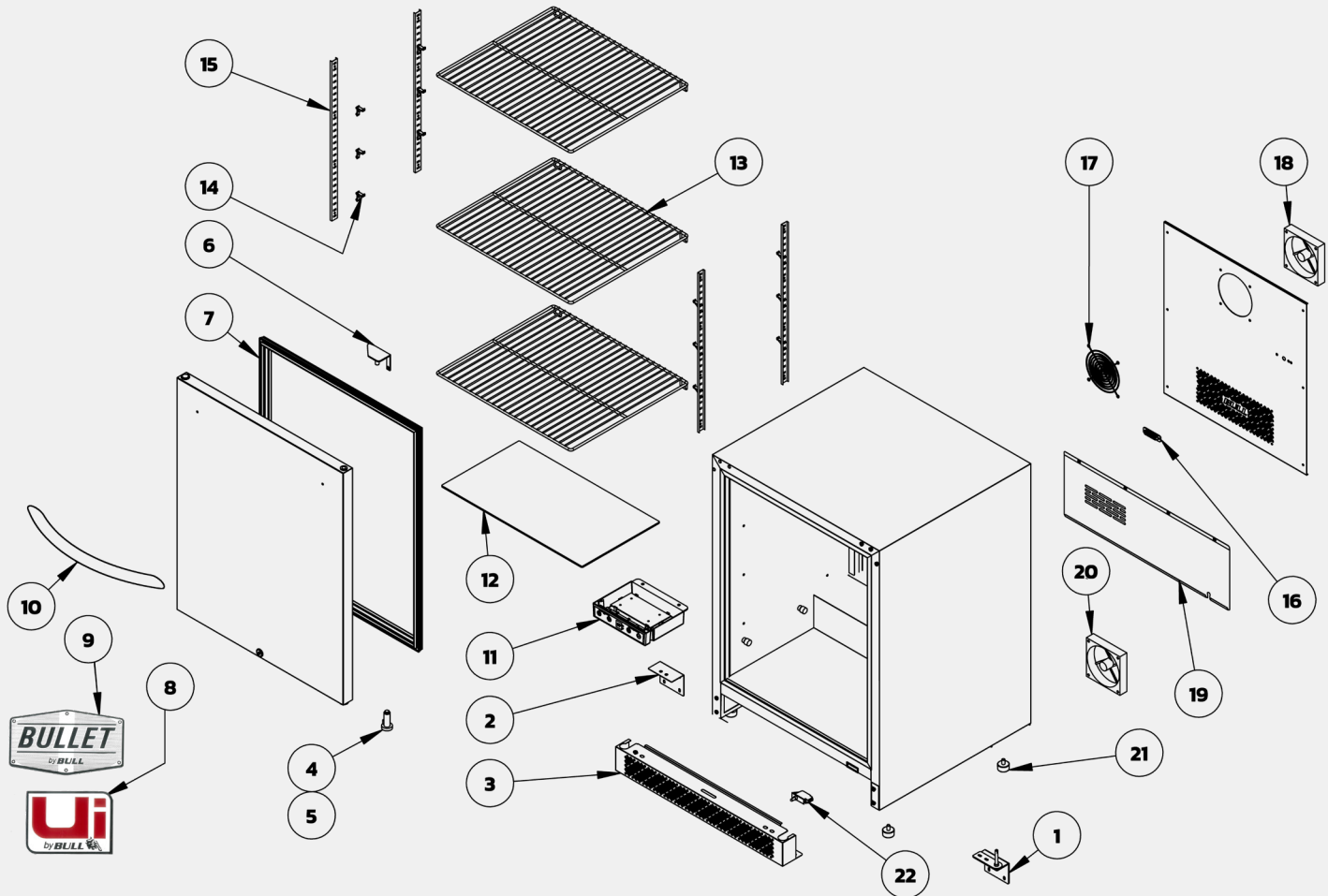

WARNING: Use of any part that is not factory authorized will void your warranty and may be dangerous.

Warranty Policy

LIMITED WARRANTY ON BULL OUTDOOR PRODUCTS, INC., PRODUCTS

THIS LIMITED WARRANTY GIVES YOU SPECIFIC LEGAL RIGHTS. YOU MAY ALSO HAVE OTHER RIGHTS, WHICH VARY FROM STATE TO STATE.

THIS LIMITED WARRANTY CAN ALSO BE FOUND ON OUR WEBSITE AT:

<https://www.bullbbq.com/support-warranty> (United States Customers)

<https://www.bullbbq.eu/customer-care/#warranty-registration-form> (International Customers)

AND IN THE OWNER'S/INSTALLATION MANUALS THAT WE PROVIDE WITH OUR PRODUCT

THIS LIMITED WARRANTY IS SUBJECT TO THE EXCLUSIONS, CONDITIONS AND LIMITATIONS SET FORTH BELOW.

ANY IMPLIED WARRANTIES IMPOSED BY LAW, INCLUDING WITHOUT LIMITATION TO THE IMPLIED WARRANTIES OF MERCHANTABILITY AND FITNESS FOR A PARTICULAR PURPOSE, ARE LIMITED IN DURATION TO THE DURATION OF THIS EXPRESSED LIMITED WARRANTY. SOME STATES DO NOT ALLOW LIMITATIONS ON HOW LONG AN IMPLIED WARRANTY LASTS, SO THE ABOVE LIMITATION MAY NOT APPLY TO YOU.

WHO MAY USE THIS WARRANTY?

BULL OUTDOOR PRODUCTS, INC. located at address 15 East Ave. Athens, TN 37303

("We") extend this limited warranty only to the consumer who originally purchased the product ("you") at the original site of delivery or installation. It does not extend to any subsequent owner or other transferee of the product. It does not extend to any rental, commercial, or non-residential application. Examples of excluded applications include, but are not limited to day care centers, schools, bed and breakfast centers, churches, private clubs, fire stations, club houses, Common areas in multi-family dwellings, restaurants, hotels, nursing homes, food service locations, and institutional food service locations.

WHAT DOES THIS WARRANTY COVER?

This limited warranty covers defects in materials and workmanship of the product and product components identified below for the Warranty Periods defined below.

WHAT IS THE PERIOD OF COVERAGE?

This limited warranty starts on the date of your purchase and lasts for the time periods specified on the next page. The Warranty Period is not extended if we replace the product. We may change the availability of this warranty at our discretion, but any changes will not be retroactive.

Warranty Policy (Continued)

Grilling/Pizza Accessories and Grill Covers DO NOT include a warranty period

Grill Warranty Periods

The following parts are covered for **1 year** on all our current gas grill models:

- The lid, control panel, grease tray, bezels, knobs, temperature gauge, valves, regulator, flex tubes, rotisserie burner, transformer, and all components of the lighting system.

The following parts are covered for **3 years** on all our current gas grill models:

- The manifold, handle end caps, flame tamers, heat shields, and warming rack.

The following parts are covered for the **Lifetime** on all our current gas grill models:

- Insert assembly and the grates.

The warranty period for the grill burners varies by type:

- Cast stainless steel burners – **Lifetime**
- Welded stainless steel burners – **5 years**
- Porcelain coated burners – **3 years**

The warranty period for the charcoal grill is **1 year** on all parts, except for the insert assembly, which is covered for **5 years**.

Component Warranty Periods

All the parts for our components /grill carts/refrigerators/kegerators/drawers/doors/refrigerator frames/grill

jackets/finishing frames/ice chest/sinks/bar center and vent hoods are covered for **1 year** with these exceptions:

• Power Burner

- o The insert/grates are **lifetime** covered parts.
- o The manifold/burner are covered for **3 years**.

• Searing Station/Slide in Double Sideburner

- o The grates are covered for **lifetime**,
- o The insert for **5 years**, and
- o The manifold for **3 years**.

• Single Sideburner

- o The grates are covered for **5 years** and
- o The burner for **3 years**.

• Sidekick

- o The burner is covered for **3 years**.

• Heaters

- o The heater replacement parts are covered for **3 years**.

• Pizza Ovens/Islands/Fire Features Warranty Periods

- o All of the parts and construction materials are covered for **1 year**.

Warranty Policy (Continued)

WHAT DOES THIS WARRANTY NOT COVER?

This limited warranty does not cover any damage due to:

- Transportation.
- Storage
- Improper installation or use.
- Use on improper fuel/gas supply.
- Failure to follow the product instructions or to perform any preventive maintenance.
- Modifications.
- Normal wear and tear, rust, corrosion, oxidation, or discoloration.
- External causes such as accidents, abuse, or other actions or events beyond our reasonable control.

WHAT OPTIONS ARE OFFERED BY BULL OUTDOOR PRODUCTS UNDER THIS WARRANTY?

With respect to any defective product claim made during the Warranty Period, we will, in our sole discretion:

- Replace such product (or the defective part) free of charge.

WHAT IS EXCLUDED BY BULL OUTDOOR PRODUCTS UNDER THIS WARRANTY?

- We will not pay for shipping charges for replacement parts, or for any labor or labor related charges.
- We will not pay for any accessory products or ancillary products purchased by you for use in connection with the product.

HOW DO YOU NOTIFY BULL CUSTOMER SERVICE OF A POTENTIAL WARRANTY ISSUE?

Our Customer Service is ready to help. Here's how to reach us:



By Phone (800) 521-2855 Monday through Friday from 8:00 a.m. to 5:00 p.m. (EDT)



To submit a warranty, claim on-line or message go to <https://www.bullbbq.com/support-warranty.com>

LIMITATION OF LIABILITY

THE REMEDIES DESCRIBED ABOVE ARE YOUR SOLE AND EXCLUSIVE REMEDIES AND OUR ENTIRE LIABILITY FOR ANY BREACH OF THIS LIMITED WARRANTY. OUR LIABILITY SHALL UNDER NO CIRCUMSTANCES EXCEED THE ACTUAL AMOUNT PAID BY YOU FOR THE DEFECTIVE PRODUCT, NOR SHALL WE UNDER ANY CIRCUMSTANCES BE LIABLE FOR ANY CONSEQUENTIAL, INCIDENTAL, SPECIAL OR PUNITIVE DAMAGES OR LOSSES, WHETHER DIRECT OR INDIRECT.

SOME STATES DO NOT ALLOW THE EXCLUSION OR LIMITATION OF INCIDENTAL OR CONSEQUENTIAL DAMAGES, SO THE ABOVE LIMITATION OR EXCLUSION MAY NOT APPLY TO YOU.

v2025.02.14