

## 2016-2023 TOYOTA TACOMA PRO SERIES FRONT WINCH BUMPER PART #TC-19338

### PARTS LIST:

1	Pro Front Bumper	2	12mm Hex Nuts
2	L-Bracket	2	8mm x 40mm Bolt Plates
2	Rubber Trims	2	8mm x 25mm Hex Bolts
2	12mm x 120mm Hex Bolts	2	8mm x 16mm Hex Bolts
2	12mm x 44mm OD x 4mm Flat Washers	8	8mm x 16mm OD x 1.6mm Flat Washers
2	12mm x 24mm OD x 2.5mm Flat Washes	6	8mm Lock Washers
2	12mm Lock Washers	4	8mm Hex Nuts

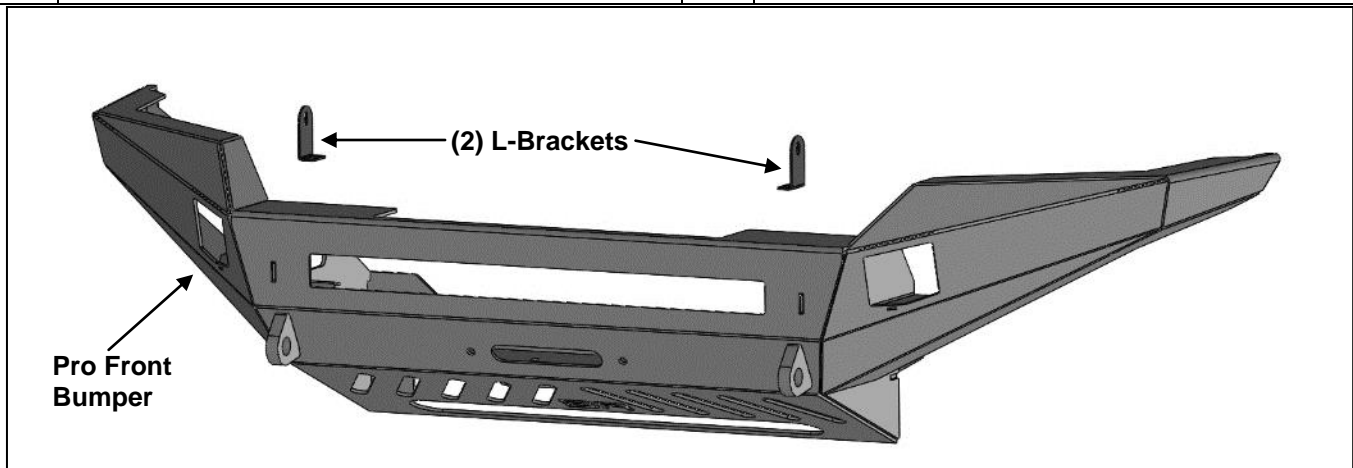

### PROCEDURE:

**REMOVE CONTENTS FROM BOX. VERIFY ALL PARTS ARE PRESENT. READ INSTRUCTIONS CAREFULLY BEFORE STARTING INSTALLATION. BUMPER IS HEAVY, ASSISTANCE IS HIGHLY RECOMMENDED TO AVOID POSSIBLE INJURY OR DAMAGE TO THE VEHICLE. CUTTING OE FRONT BUMPER IS REQUIRED.**

- Starting at the Driver/Left front side of the vehicle, locate the area above the fog light. Use a tape measure to measure a downwards distance of 2-7/8" from the bodyline, **(Figure 1)**. Use removable tape/marker to make a straight horizontal line across the Front Bumper, **(Figure 1)**.
- Move towards the Driver/Left side front fender flare. Locate the Driver/Left side end of the front bumper. Measure a downward distance of 6-5/8" from the top outer end of the front bumper and headlight intersection, **(Figure 2)**. Use tape/marker to mark the position. Measure a downward distance of 3-1/8" from the lower outer end of the front bumper and fender intersection, **(Figure 2)**. Use tape/marker to mark the position.
- Use tape/marker to connect across all three measured distances from the fog light opening to the end of the front fender flare, **(Figure 3)**.
- Remove the factory bolts along the inside of the Driver/Left front side of the wheel well to remove fender flare, **(Figure 4)**. Set the fender flare on a clean flat surface.
- Use tape/marker to extend the marked line on the front bumper cover to the end of the front bumper to the wheel opening, **(Figure 5)**.
- Use a sharp knife or hacksaw blade to carefully cut the fender flare along the marked line.  
**IMPORTANT:** For best fit, leave 1/4in of material when cutting to make any proper adjustments at the end of the install.
- Repeat **Steps 1—6** to mark the Passenger/Right side front fender flare and front bumper. Repeat **Step 6** to cut the Passenger/Right side fender flare.

8. Remove the air dam from the bottom of the bumper and remove the skid plate, if equipped, **(Figure 6)**. On models with factory fog lights, unplug both lights and harness leading to bumper.
9. Open the hood and remove the plastic cover from the top of the radiator and grille, **(Figure 7)**. Next, carefully remove the plastic grille, **(Figures 7 & 8)**.
10. Remove the hardware attaching the plastic bumper cover at the top, ends and bottom. With assistance, pop the ends off of the inner clip and pull the bumper off and away from the vehicle, **(Figures 8 & 9)**. Set the plastic bumper cover on a clean flat surface. Use a sharp knife or hacksaw blade to carefully cut along the marked line. **IMPORTANT:** For best fit, leave 1/4in of material when cutting to make any proper adjustments at the end of the install.
11. Remove the plastic impact pads, aluminum cross bar and cross bar brackets, **(Figure 9)**.
12. Determine if the vehicle is equipped with a bolt-on tow hook and/or a power steering cooler, **if not equipped, proceed to Step 13.**

**Models equipped with a passenger side bolt on tow hook:** remove tow hook, **(Figures 10 & 11)**.

**Models equipped with a power steering cooler:**

- a. Locate the (2) bolts attaching the cooler to the top of the front cross member, **(Figures 12 & 13)**. Temporarily, remove the (2) factory bolts.
  - b. Select (1) 8mm Bolt Plate, **(Figure 14)**. Hold the bolt on the bolt plate up and reuse the factory bolt to attach the Bolt Plate to the top of the cross member, **(Figure 15)**. Repeat to install the remaining Bolt Plate on the passenger/right side cooler mounting location.
  - c. Rotate the Bolt Plates so that the bolt on the Bolt Plate is towards the rear of the vehicle.
  - d. Next, attach the cooler to the bolt plates with (2) 8mm x 16mm Flat Washers, (2) 8mm Lock Washers and (2) 8mm Hex Nuts, **(Figures 14 & 15)**.
13. Reinstall the trimmed plastic bumper pieces, **(Figure 16)**. Reuse the factory fender hardware to install the trimmed front fender flares, **(Figure 17)**.
  14. Reinstall the grille and plastic cover.
  15. Next, set the Desert Front Bumper on a stable, clean and flat surface.
  16. **For Light installation (Lights not included)**
    - a. Select (1) L-Bracket. Attach the Bracket to the back of the bumper with (1) 8mm x 25mm Hex Bolt, (2) 8mm Flat Washers, (1) 8mm Lock Washer and (1) 8mm Hex Nut, **(Figure 18)**. Repeat this **Step** to attach the remaining (1) L-Bracket to the other side of the Bumper.
    - b. Attach Light Bar to the (2) L-Brackets with (2) 8mm x 16mm Hex Bolts, (2) 8mm Lock Washers and (2) 8mm Flat Washers, **(Figure 19)**, (Light Bar not included).
    - c. Attach Light Cubes to the side mounting tabs on the back of the Bumper, **(Figure 20)**, (Light Cubes not included).
  17. **Winch installation** (sold separately).
    - a. Attach the winch to the center mounting plate on the Bumper.
    - b. Follow winch manufacturer's instructions to properly install the winch.
  18. Locate the mounting location, (frame studs), for the Bumper, **(Figure 21)**. With assistance, position the Bumper up to the frame bracket studs. Temporarily support the weight of the Bumper. **WARNING:** To avoid possible injury or damage to the vehicle, do not proceed until the Bumper is fully and safely supported.
  19. **For Bumper attachment**
    - a. Reuse the (6) factory flange nuts, (2-outer studs, 1-inner stud; **per side**) to attach the Bumper Assembly to the studs, **(Figure 22)**. Do not tighten hardware.
    - b. Attach the Bumper to the lower frame with (2) 12mm x 120mm Hex Bolts, (2) 12mm x 32mm Flat Washers, (2) 12mm x 44mm Flat Washers, (2) 12mm Lock Washers and (2) 12mm Hex Nuts, **(Figure 22)**. Do not tighten hardware.
  20. Level and adjust the Bumper as needed and tighten all hardware at this time.
  21. Once the Bumper has been installed, trim the fender liners for proper fit as necessary, **(Figure 9)**.
  22. Reinstall the skid plate, if equipped.

23. **WARNING:** For heavy winch loads, it is recommended that **Front Bumper Reinforcement Brackets**, (sold separately), is installed.
24. Do periodic inspections to the installation to make sure that all hardware is secure and tight.

**To protect your investment,** Do not use any type of polish or wax that may contain abrasives that could damage the finish. Mild soap may be used to clean the Bumper assembly.

## Driver/Left side Installation Pictured

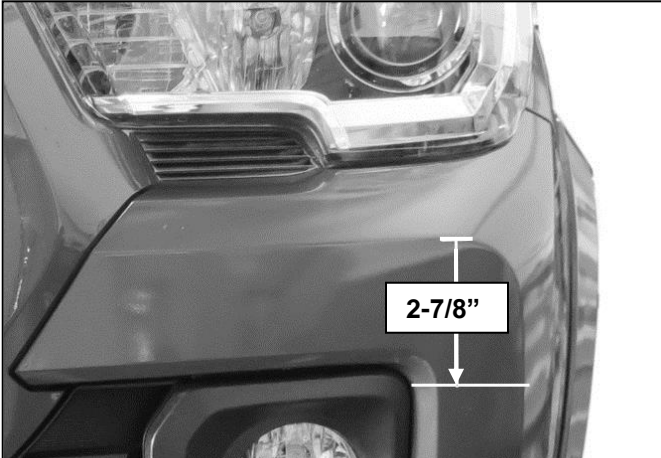

(Fig 1) Locate the Driver/left side factory fog light. Measure downwards 2-7/8" from the top of the bodyline. Use tape/marker to trace a line across.

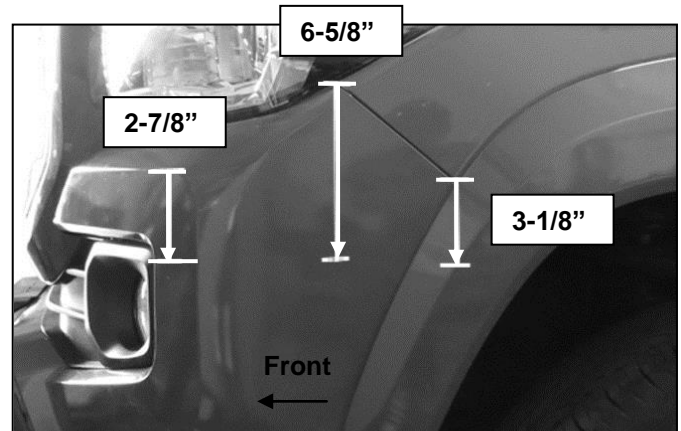

(Fig 2) Measure downwards 6-5/8" from the top of the Front Bumper and headlight intersection. Measure downwards 3-1/8" from the top of the Front Bumper and Fender intersection. Use tape/marker to connect a line with all three measurements.

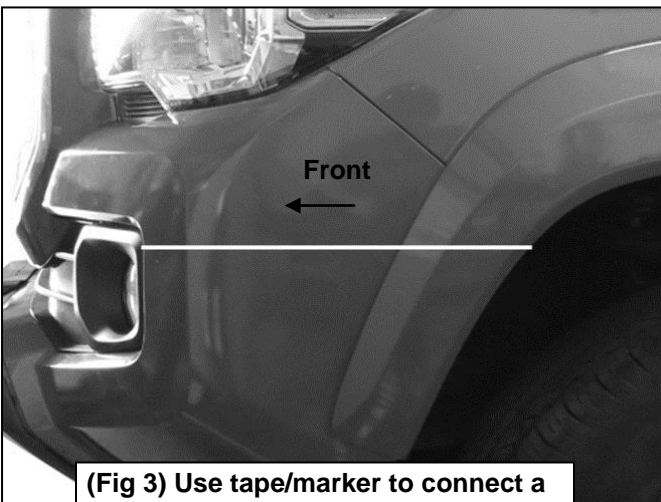

(Fig 3) Use tape/marker to connect a line across all three measurements

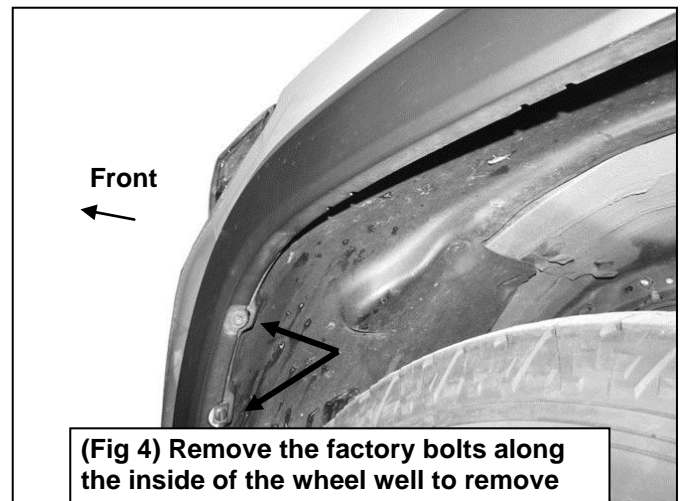

(Fig 4) Remove the factory bolts along the inside of the wheel well to remove the driver/left front side Fender Flare



## Driver/Left side Installation Pictured

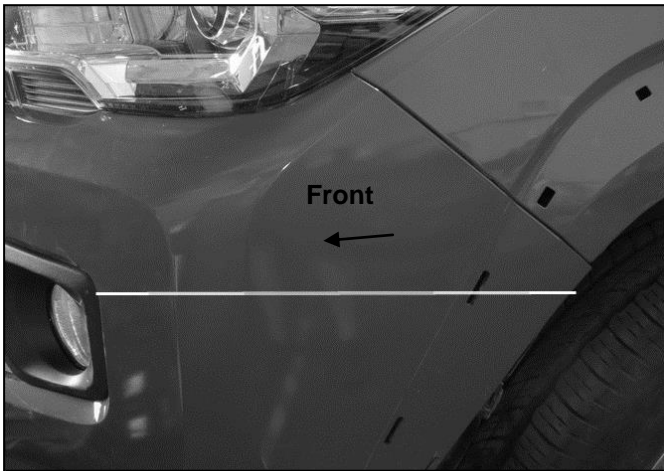

(Fig 5) Use tape/marker to extend the line on the Front Bumper (Fender Flare removed)

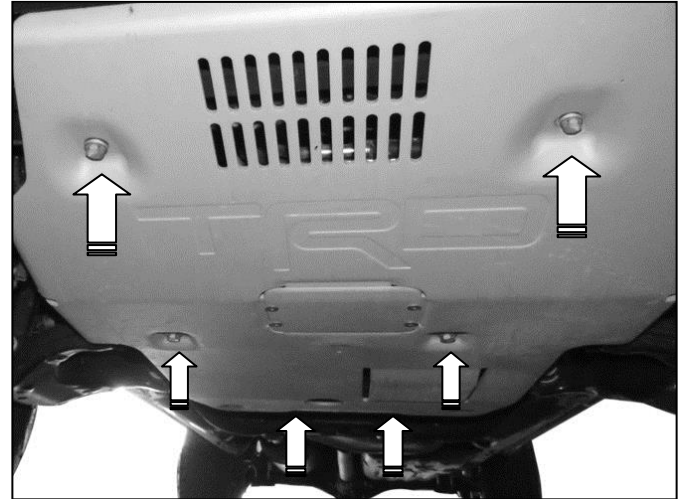

(Fig 6) Remove Skid Plate and air dam, if equipped

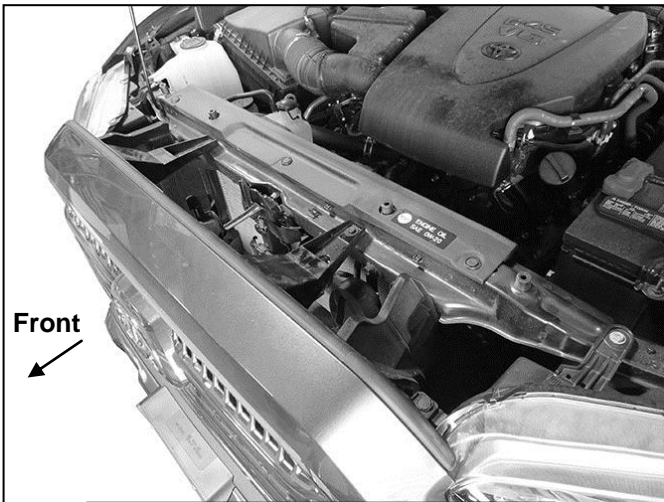

(Fig 7) Remove plastic cover from top of radiator and remove grille

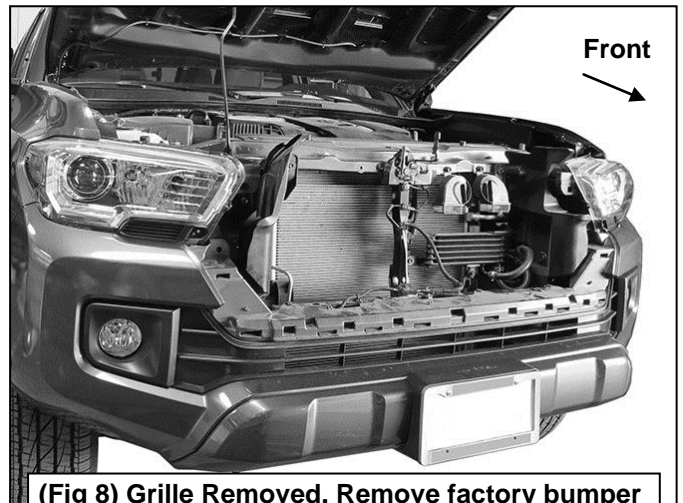

(Fig 8) Grille Removed. Remove factory bumper bolts along the top and bottom of Bumper

Driver/Left side Installation Pictured



(Fig 9) Remove plastic impact bumper and aluminum crossbar from bumper brackets. Once the Bumper has been installed, trim the plastic covers at the ends as necessary (dashed line)

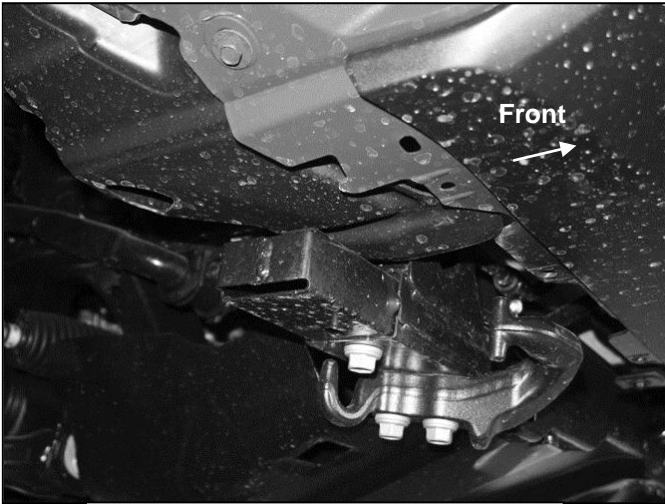

(Fig 10) Remove passenger/right side tow hook, if equipped

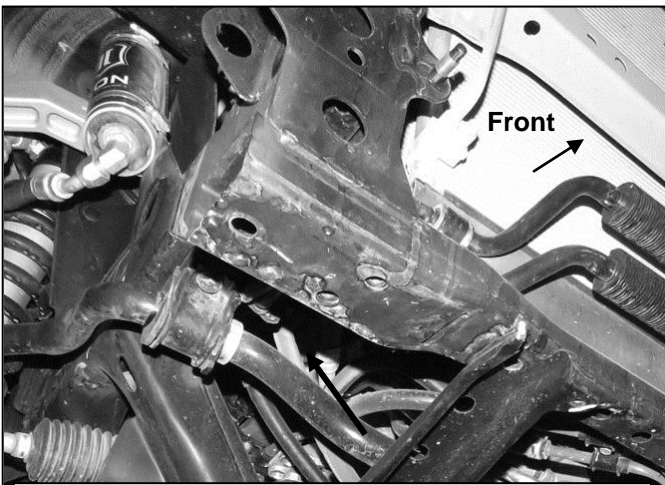

(Fig 11) Passenger/right side tow hook removed

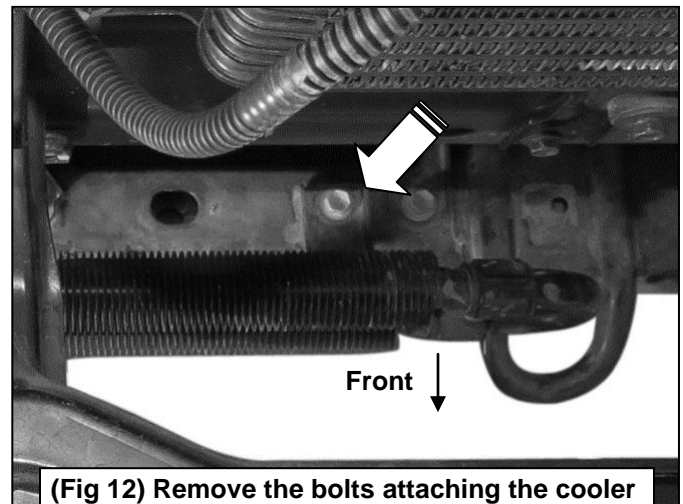

(Fig 12) Remove the bolts attaching the cooler to the top of the crossmember, if equipped

**NOTE:** Bolt Plates are used to relocate the cooler, if equipped, towards the rear of the vehicle to create space for the winch mounting plate on the back of the Bumper.



Driver/Left side Installation Pictured

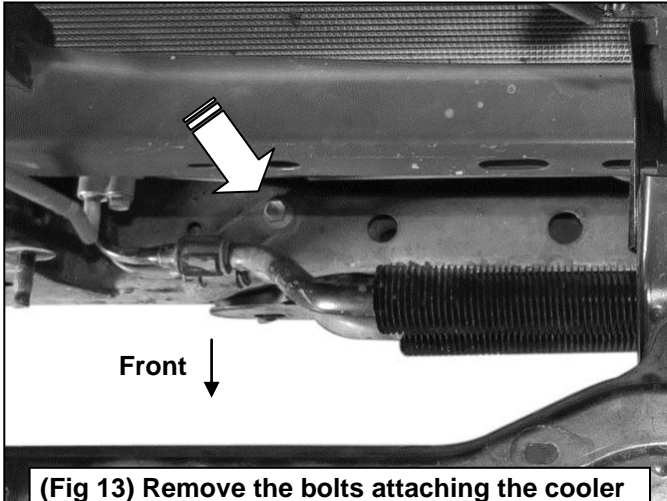

(Fig 13) Remove the bolts attaching the cooler to the top of the crossmember, if equipped

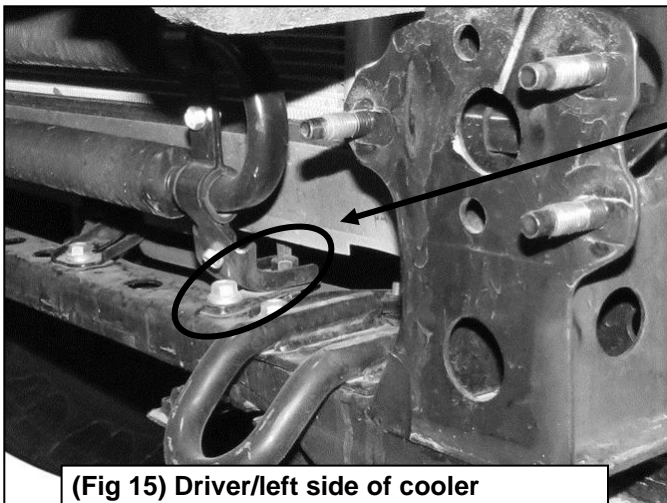

(Fig 15) Driver/left side of cooler relocated towards the rear of the vehicle

8mm x 16mm Flat Washer  
8mm Lock Washer  
8mm Hex Nut

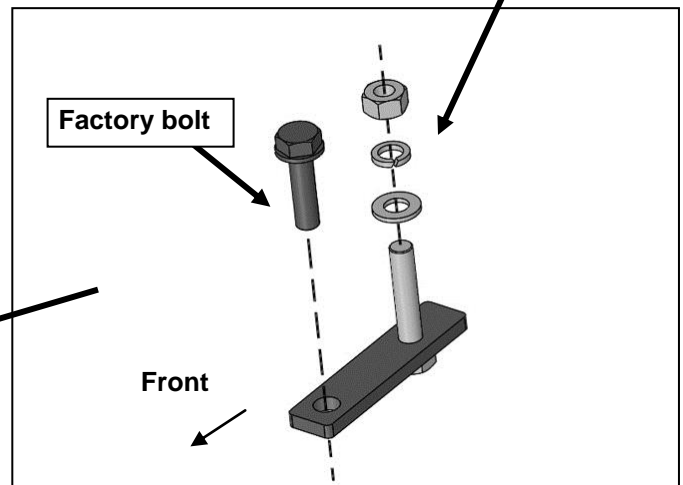

(Fig 14) Insert the factory bolt through the hole in the Bolt Plate to attach Bolt Plate to the cross member. Slide the cooler over the bolt on the Bolt Plate and secure with provided hardware



(Fig 16) Use the factory clips and bolts to attach the trimmed Front Bumper (arrows)

Driver/Left side Installation Pictured

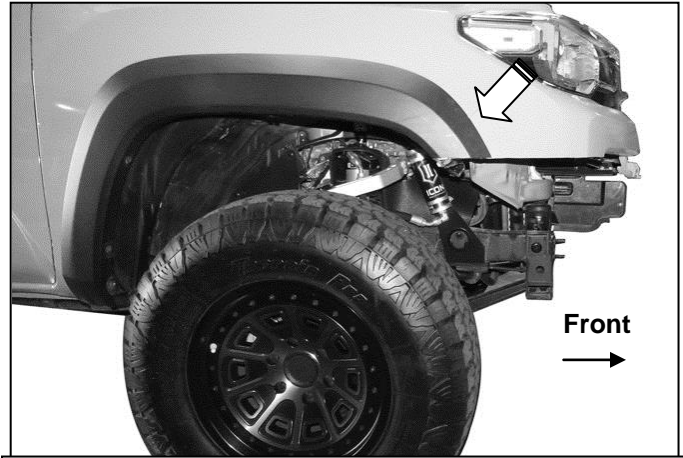

(Fig 17) Reuse the factory fender bolts to attach the front Fender Flares (passenger/right side pictured)

8mm x 25mm Hex Bolt  
(2) 8mm Flat Washers  
8mm Lock Washer  
8mm Hex Nut

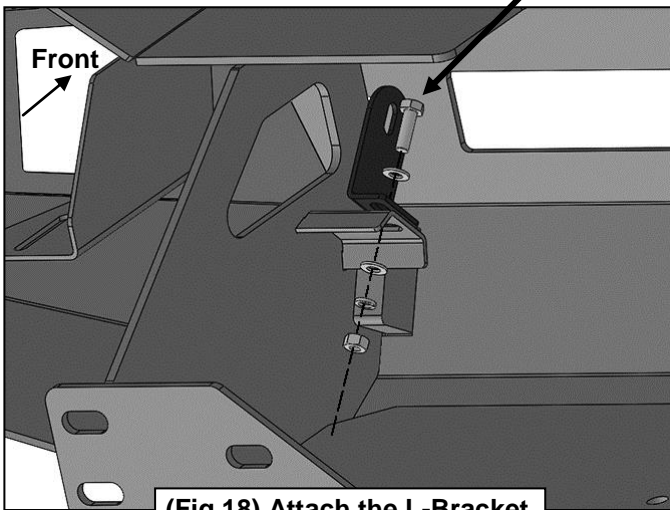

(Fig 18) Attach the L-Bracket to the back of the Bumper

8mm x 16mm Hex Bolt  
8mm Lock Washer  
8mm Flat Washer

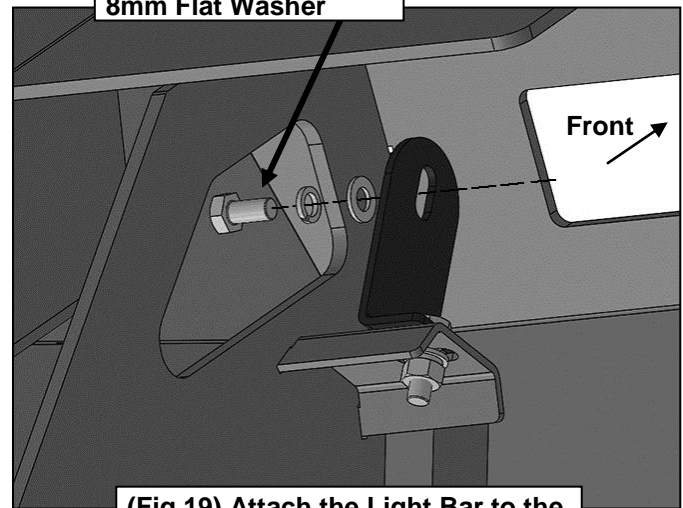

(Fig 19) Attach the Light Bar to the L-Brackets, (light bar not included)



Driver/Left side Installation Pictured

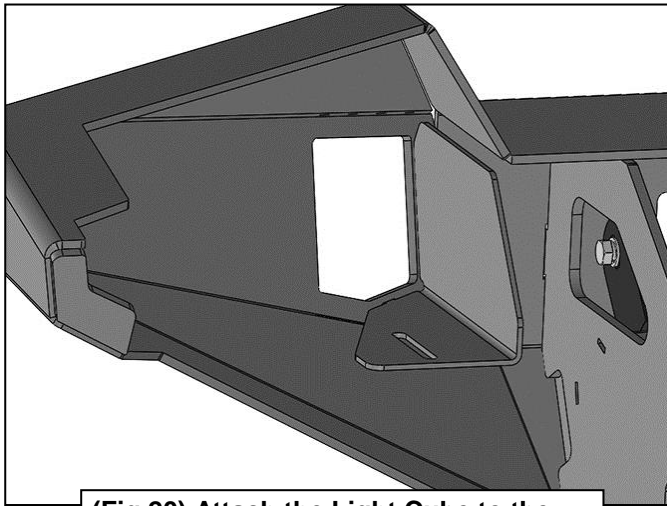

(Fig 20) Attach the Light Cube to the mounting tab, (light cube not included)

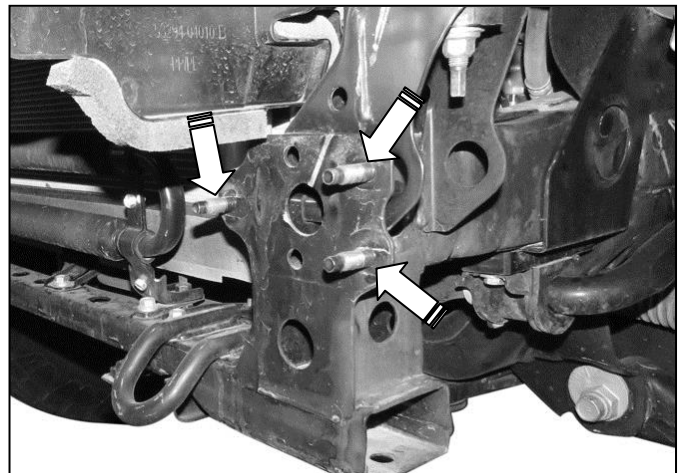

(Fig 21) Driver/left side mounting location (arrows)

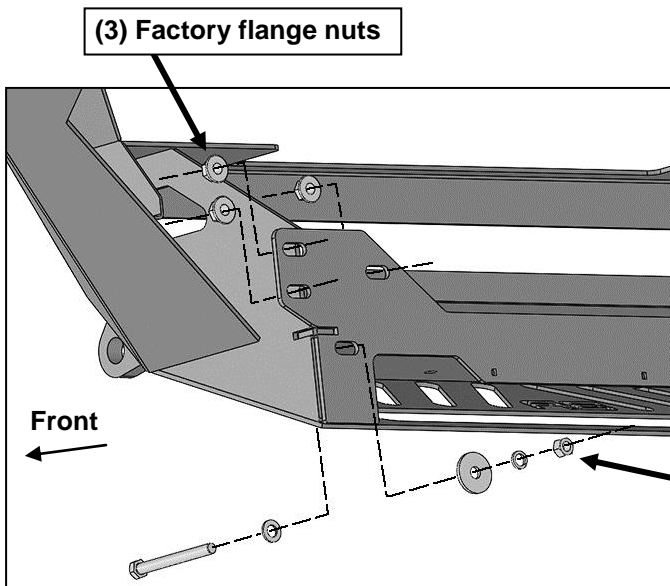

(3) Factory flange nuts

(Fig 22) Reuse (3) factory flange nuts to attach the Bumper assembly to the frame studs

**WARNING!** Do not crawl under bumper unless the bumper is properly supported on blocks or stands or the bumper may fall.

- 12mm x 120mm Hex Bolt
- 12mm x 32mm Flat Washer
- 12mm x 44mm Flat Washer
- 12mm Lock Washer
- 12mm Hex Nut