

2018-2020 FORD F-150 AMBUSH REAR BUMPER PART #FD-2967

PARTS LIST:

1	Rear Bumper Assembly	6	14mm Plastic Retainers
1	Driver/left Mounting "L" Bracket	8	10mm Plastic Retainers
1	Passenger/right Mounting "L" Bracket	2	10mm x 35mm Long Double Bolt Plates
1	Driver/left Mounting Bracket	2	10mm x 35mm Short Double Bolt Plates
1	Passenger/right Mounting Bracket	8	10mm x 30mm x 2.5mm Flat Washers
2	Plastic Plugs for license plate mount	8	10mm Nylon Lock Nuts
4	Sensor Covers	8	4mm x 15mm Self Tapping Screws
4	Sensor Retaining Caps	1	4mm Wrench
4	20mm x 10mm Foam Spacers	2	Wire Extensions
4	15.5mm x 25mm x 2mm Foam Washers	10	Nylon Wire Ties
1	Sensor Cover Kit		

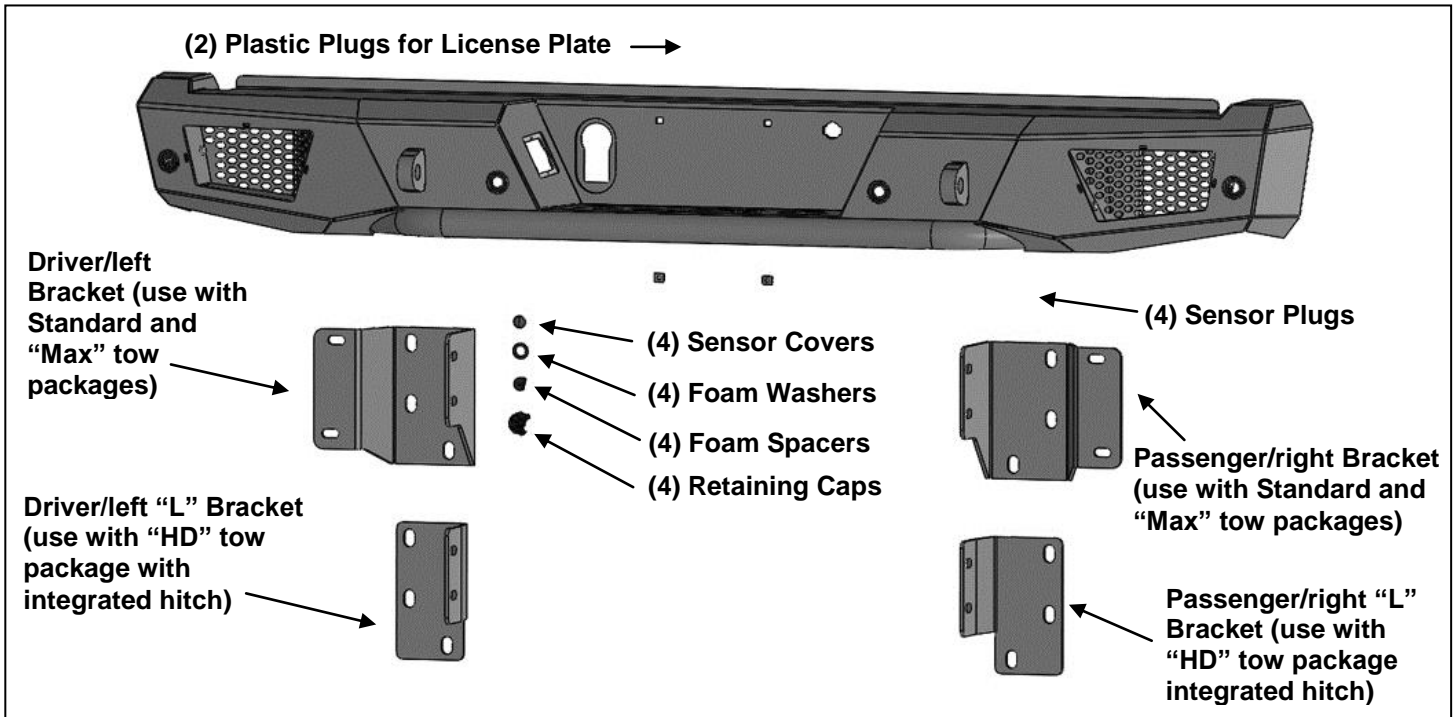

PROCEDURE:

REMOVE CONTENTS FROM BOX. VERIFY ALL PARTS ARE PRESENT. READ INSTRUCTIONS CAREFULLY BEFORE STARTING INSTALLATION. BUMPER IS HEAVY, ASSISTANCE IS RECOMMENDED TO AVOID POSSIBLE INJURY OR DAMAGE TO THE VEHICLE.

IMPORTANT: OEM BUMPER REINFORCEMENT USED WITH "STANDARD" TOW PACKAGE WITHOUT RECEIVER HITCH CANNOT BE REINSTALLED. OE INTEGRATED "HD" HITCH, "MAX DUTY" HITCH AND MOST AFTERMARKET RECEIVER HITCHES REQUIRED FOR TOWING.

1. Remove the license plate from the bumper, (Figure 1). Unplug all wiring harnesses leading to the rear bumper and move harnesses away from bumper, (Figure 2). **NOTE:** Bumper is designed to be compatible with larger 7-wire universal trailer harness plug only.
2. Place blocks or jack stands under the bumper to support it during mounting bolt removal. Once the bumper has been safely supported, remove the hardware attaching the bumper assembly to the end of

the frame, (**Figure 3A, 3B & 4**). On models with “Max Duty” separate receiver hitch, do not remove hitch from bottom of frame. **WARNING!** Assistance is required to hold the bumper in place during hardware removal.

3. Disassemble the bumper to remove sensors, (if equipped), license plate lights, trailer plug and wiring harness, (**Figure 5**). On models with “HD” tow package with integrated hitch, remove hitch/bracket assembly from back of factory bumper.
4. **Determine if the vehicle is equipped with sensors. NOTE:** Sensors, (if equipped), must be installed before attaching Bumper to the vehicle.

Models without bumper sensors:

- a. Select the included (4) Sensor Covers.
- b. From the front of the bumper, push Covers into sensor mounting holes, (**Figure 6**).

Models with bumper mounted sensors:

- a. Remove the small factory sealing washer from the sensor. Attach the provided larger (1) Foam Washer to the front of the sensor, (**Figure 7**).
- b. Push the sensor in from the back of the Bumper until it is flush with the sensor mount.
- c. Attach the adhesive side of (1) Foam Spacer to (1) Retaining Clip. Push the Retaining Cap onto the sensor mount until it locks onto the mounting sleeve, (**Figure 8**).
- d. Repeat the previous steps to attach each sensor to the back of the Bumper.
5. **LED light installation at ends of bumper** (sold separately).
 - a. Insert light into opening and up to mounting slot. Check for clearance between front and back of light. If necessary, remove the screen from the back of the opening for additional clearance or access to light, (**Figure 9**).
 - b. Follow manufacturer’s instructions to attach light to slot in the top of opening and to connect to electrical system.
 - c. Repeat the above steps for passenger side light installation.
6. Reinstall the license plate lights, trailer plug and wiring harness, (**Figure 10**). **NOTE:** Use a flat blade screwdriver to carefully pry out the metal clips on the trailer plug to grab the edge of the opening If needed. Use the included Wire Ties to secure the wiring harness to the bumper as necessary. Plug sensors, if equipped, and license plate lights into bumper wiring harness.
7. Use a small flat blade screwdriver to pry the star washers off of the bolt plates used to attach the factory bumper to the end of the frame, (**Figure 11**). **NOTE:** “HD” tow package models use a triple bolt plate, “Standard” and “Max Duty” equipped models use a double bolt plate.
8. **Determine towing package supplied with vehicle:**

Models with “standard tow package” without HD receiver below bumper and models with “Max Duty,” separate frame mounted receiver hitch below bumper.

 - a. Select (1) 10mm “Short” Double Bolt Plate. Insert the Bolt Plate into the side of the mounting plate on the back of the driver/left side of the Bumper, (**Figures 12 & 13**).
 - b. Attach the inner facing side of the larger Mounting Bracket to the Bolt Plate with (2) 10mm Flat Washers and (2) 10mm Nylon Lock Nuts, (**Figures 14 & 15**). Do not tighten at this time.
 - c. Select (1) 10mm “Long” Double Bolt Plate. Insert the Bolt Plate into the outer end of the mounting plate on the bumper and through the larger Mounting Bracket, (**Figures 12, 13 & 15**). Attach the Mounting Bracket to the Long Bolt Plate with (2) 10mm Flat Washers and (2) 10mm Nylon Lock Nuts, (**Figure 15**). Do not tighten.
 - d. Insert the factory double bolt plate into the Mounting Bracket and out through the slots. Thread (2) 14mm Plastic Retainers onto the bolt plate to hold it in position, (**Figure 16**).
 - e. Repeat the previous Steps to install the passenger/right Mounting Bracket and factory bolt plate.
 - f. With assistance, hold the Bumper assembly up to the end of the frame. Temporarily support the weight of the Bumper. **WARNING:** To avoid possible injury or damage to the vehicle, do not proceed until the bumper is fully and safely supported.
 - g. Reuse the factory hex nuts to attach the Bumper Brackets with bolt plates to the frame, (**Figure 16**). Snug but do not fully tighten hardware at this time.

Models with “HD” tow package with integrated receiver hitch built into bumper and brackets.

- a. Select (1) 10mm “Short” Double Bolt Plate. Insert the Bolt Plate into the side of the mounting plate on the back of the Bumper, **(Figures 12, 13 & 17)**.
 - b. Attach the driver/left “L” Mounting Bracket to the Bolt Plate with (2) 10mm Flat Washers and (2) 10mm Nylon Lock Nuts, **(Figures 14 & 17)**. Do not tighten at this time.
 - c. Select (1) 10mm “Long” Double Bolt Plate. Insert the Bolt Plate into the outer end of the mounting plate, **(Figures 12, 13 & 17)**. Thread (2) 10mm Plastic Retainers onto the threaded end of the Bolt Plate to help hold it in place.
 - d. Repeat the previous Steps to attach the passenger/right “L” Mounting Bracket and Long Double Bolt Plate, **(Figures 12, 13 & 17)**.
 - e. With assistance, attach the receiver/bumper bracket assembly to the Long Double Bolt Plates in the back of the Bumper with (4) 10mm Flat Washers and (4) 10mm Nylon Lock Nuts, **(Figure 18)**.
 - f. Insert the factory triple bolt plate into the driver/left Mounting Bracket and out through the slots. Thread (2) 14mm Plastic Retainers onto the bolt plate to hold it in position, **(Figure 18)**. Repeat this Step to install the passenger/right factory bolt plate.
 - g. With assistance, hold the Bumper with hitch assembly up to the ends of the frame. Temporarily support the weight of the Bumper. **WARNING:** To avoid possible injury or damage to the vehicle, do not proceed until the bumper is fully and safely supported.
 - h. Reuse the factory hex nuts to attach the Bumper and receiver with bolt plates to the frame, **(Figure 18)**. Snug but do not fully tighten hardware at this time.
9. Level and adjust the bumper and fully tighten all hardware.
 10. Plug bumper and trailer wiring harness into main harness. .
 11. Do periodic inspections to the installation to make sure that all hardware is secure and tight.

To protect your investment, Do not use any type of polish or wax that may contain abrasives that could damage the finish. Mild soap may be used to clean the Bumper assembly.

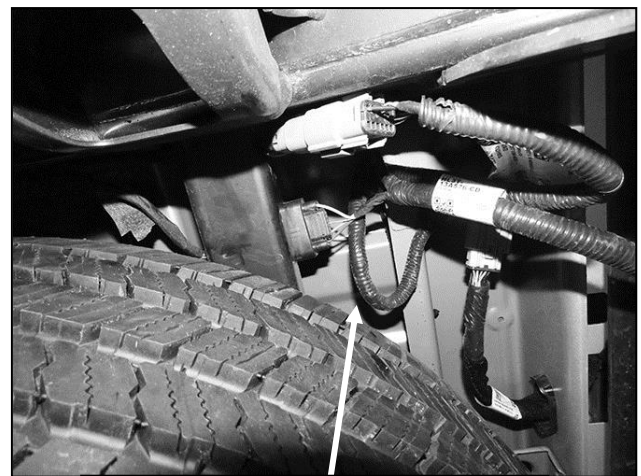
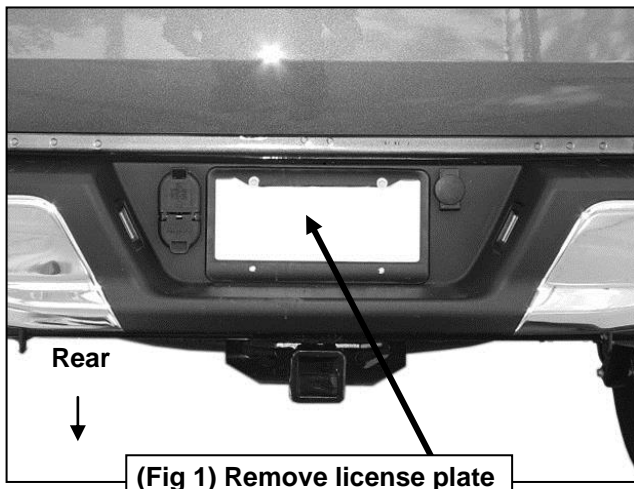

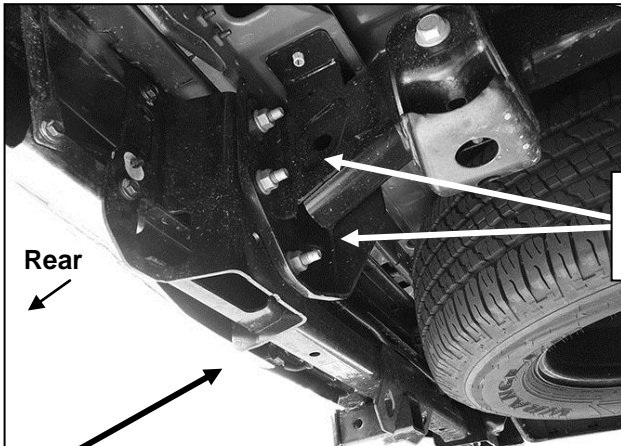

Remove the factory hex nuts attaching bumper assembly to frame

(Fig 3A) Note bumper with "HD" tow package receiver hitch integrated into bumper bracket

WARNING! Do not crawl under bumper unless the bumper is properly supported on blocks or stands or the bumper may fall.



(Fig 3B) Remove the factory hex nuts attaching bumper assembly to frame. STD tow package model pictured (no receiver hitch)

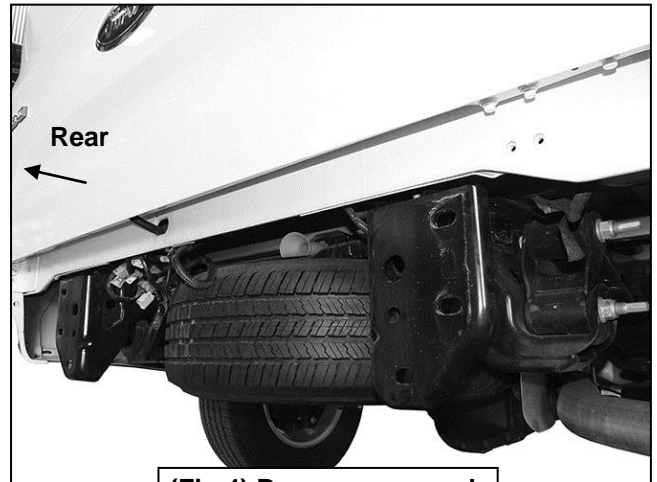

(Fig 4) Bumper removed



(Fig 5) Disassemble bumper to remove license plate lights, trailer plug, sensors and wiring harness from bumper as equipped

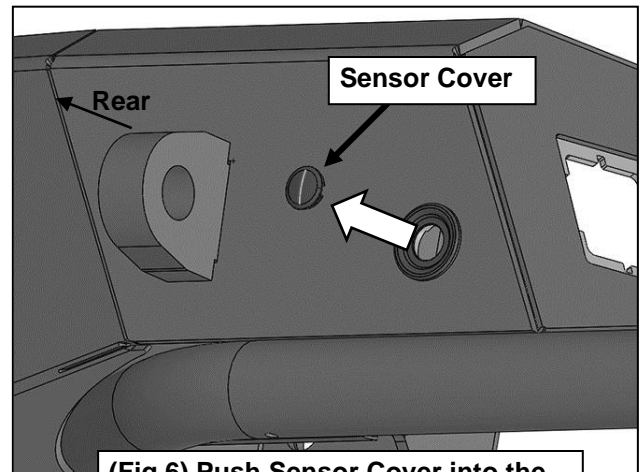

(Fig 6) Push Sensor Cover into the front of the sensor mounting sleeve

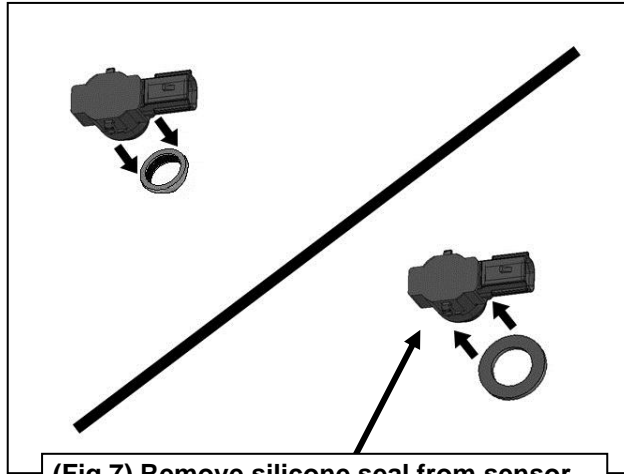

(Fig 7) Remove silicone seal from sensor. Slide large Seal over end of sensor (arrow)

Driver/left Side Installation Pictured

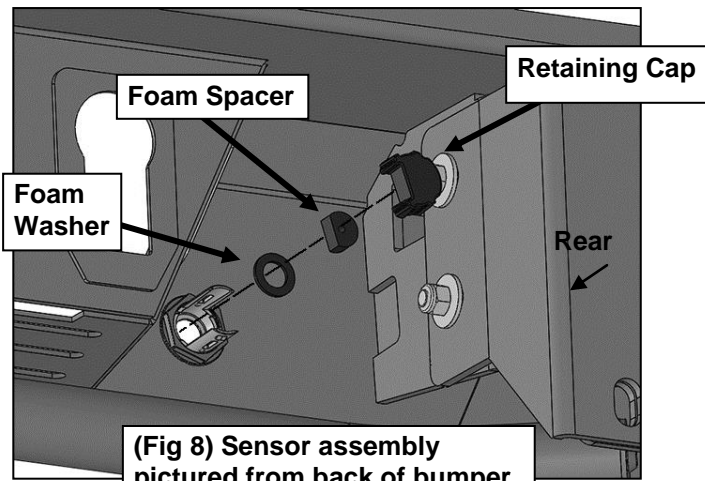

(Fig 8) Sensor assembly pictured from back of bumper

WARNING! Do not remove bumper bolts unless the bumper is properly supported on blocks or stands or the bumper may fall.

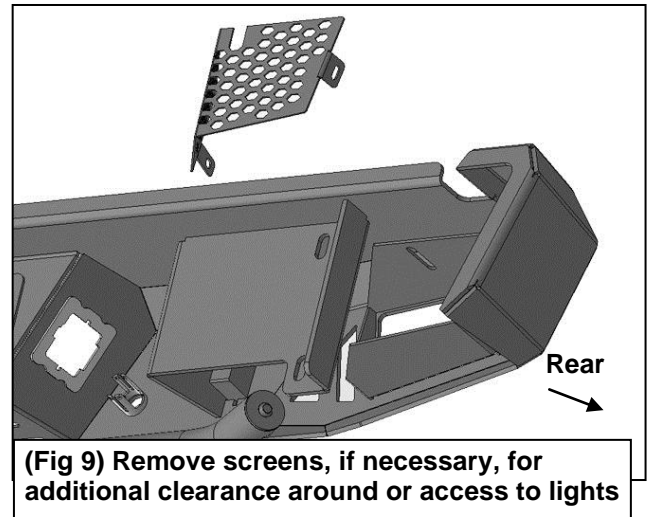

(Fig 9) Remove screens, if necessary, for additional clearance around or access to lights

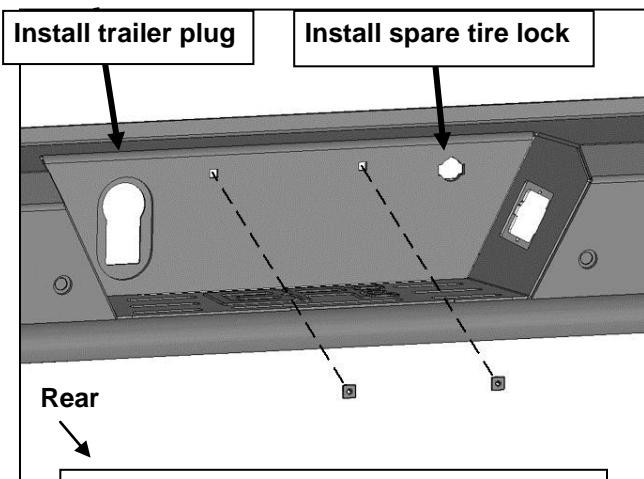

(Fig 10) Push plastic plugs into holes for license plate. Install license plate lights

Driver/left Side Installation Pictured

WARNING! Do not crawl under bumper unless the bumper is properly supported on blocks or stands or the bumper may fall.

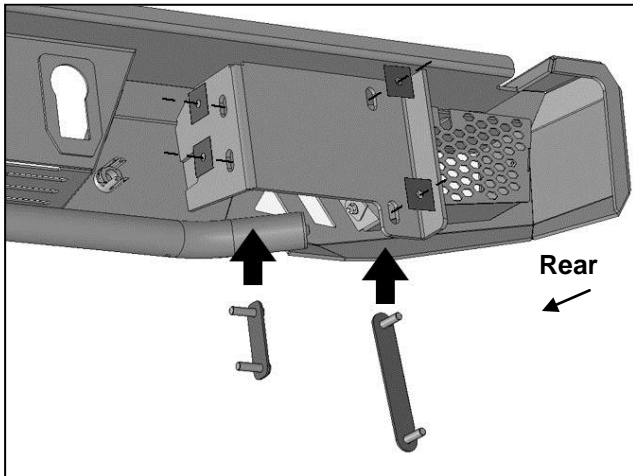

(Fig 12) Insert "Short" and "Long" 10mm Double Bolt Plates into back of Bumper. Use 10mm Plastic Retainers to hold Bolt Plates in position (retainer use optional)

Use with standard (no receiver hitch) or "Max tow" package with separate receiver hitch

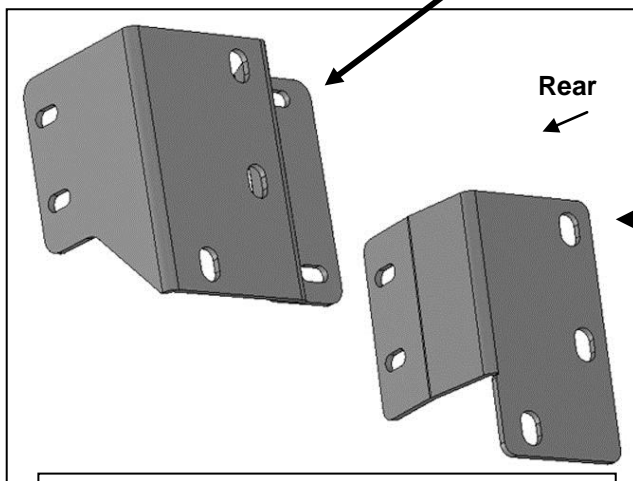

(Fig 14) Select correct driver/left side Mounting Bracket to fit vehicle tow package

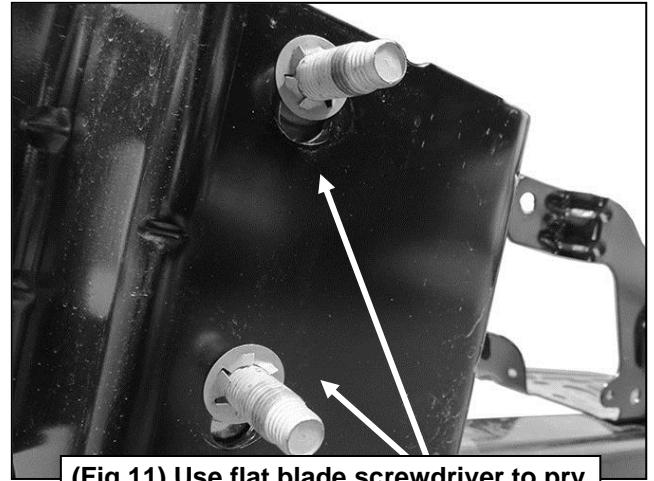

(Fig 11) Use flat blade screwdriver to pry off lock washers from factory bolt plates

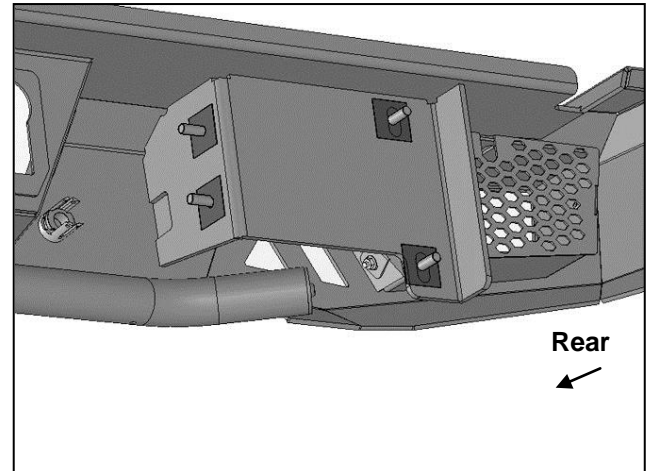

(Fig 13) "Short" and "Long" 10mm Double Bolt Plates in position (Retainer use optional)

"L" Bracket, use with "HD tow" package with integrated receiver hitch

Driver/left Side Installation Pictured

WARNING! Do not crawl under bumper unless the bumper is properly supported on blocks or stands or the bumper may fall.

Use with standard (no receiver hitch) or "Max tow" package with separate receiver hitch

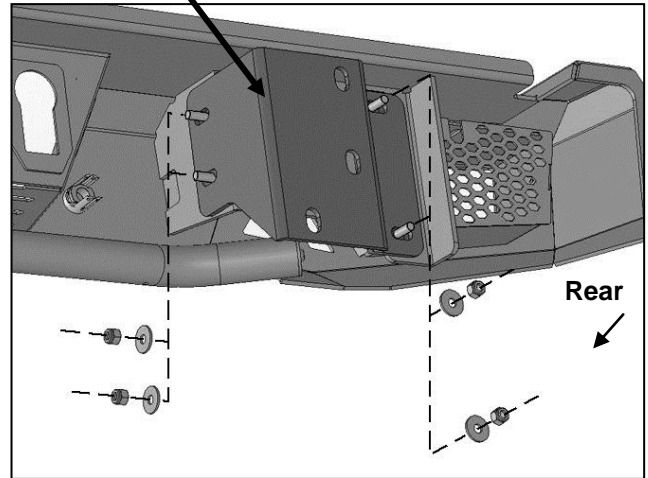

(Fig 15) Attach driver/left Mounting Bracket to Long and Short 10mm Double Bolt Plates

Reuse factory hex nuts to attach Bumper assembly to end of frame

(2) 14mm Plastic Retainers

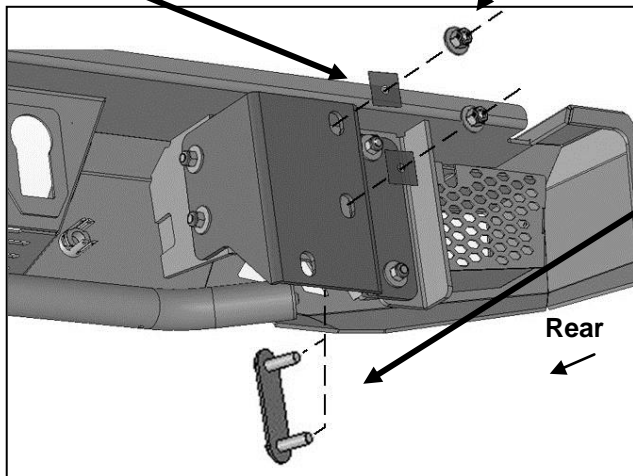

(Fig 16) Insert factory bolt plate into and through Mounting Bracket on back of Bumper

Factory double bolt late used on model's w/o receiver hitch and "max tow" frame mounted receiver hitch

(2) 10mm Flat Washers
(2) 10mm Nylon Lock Nuts

10mm "Long" Double Bolt Plate

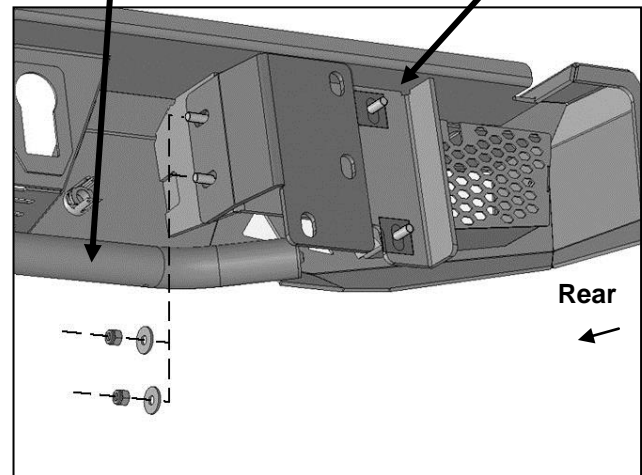

(Fig 17) Models with "HD" tow package with integrated receiver hitch, attach driver /left "L" Mounting Bracket to "Short" 10mm Double Bolt Plate (see Fig 11)

Driver/left Side Installation Pictured

