

**Ambush Side Step for 07-18 Silverado 1500 Crew Cab
07-19 SILVERADO 2500/3500 CREW CAB
(Incl. Diesel models with DEF tanks) (Rocker Panel Mount)
PART #GM-4201**

PARTS LIST:

1	Driver/Left Ambush Side Step	16	10mm Nylon Lock Nuts
1	Passenger/Right Ambush Side Step	1	8mm Bolt Plate
7	Mounting Brackets	17	8mm x 25mm Hex Bolts
1	Passenger/Right Front Upper Bracket	17	8mm Lock Washers
1	Passenger/Right Front Lower Bracket	17	8mm x 24mm OD x 2mm Flat Washers
16	10mm x 30mm Hex Bolts	1	8mm Nylon Lock Nut
32	10mm x 20mm OD x 2mm Flat Washers	15	8mm Clip Nuts

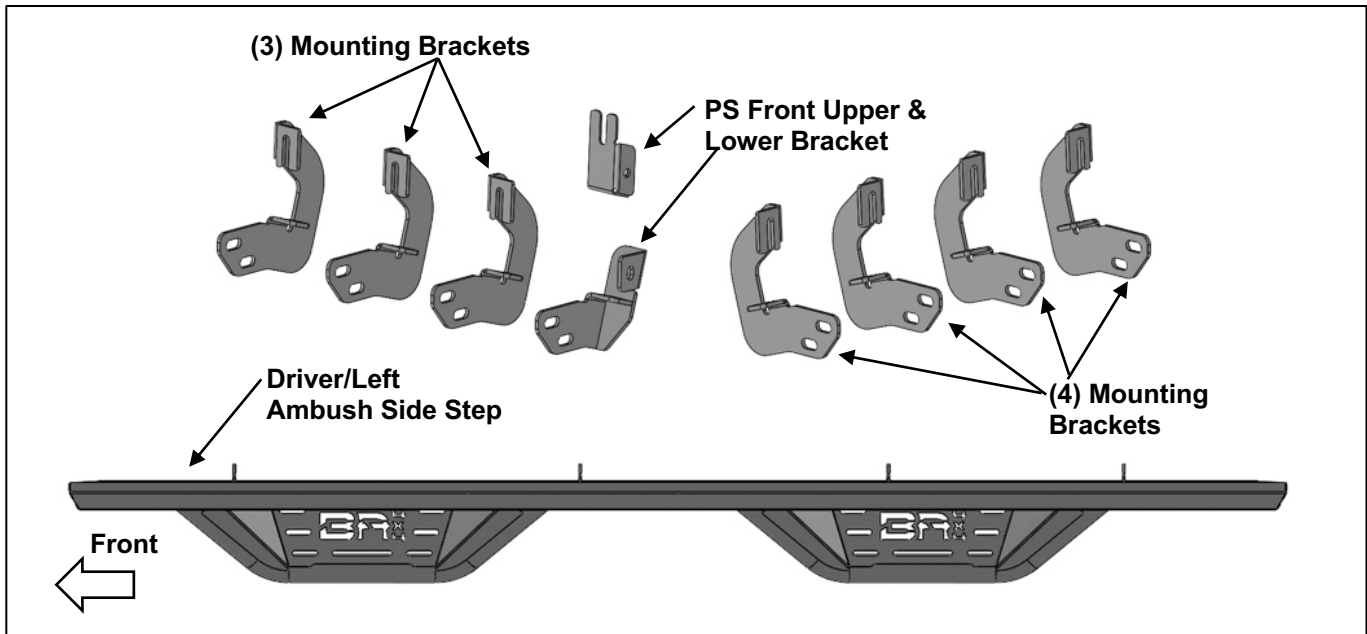

PROCEDURE:

REMOVE CONTENTS FROM BOX. VERIFY ALL PARTS ARE PRESENT. READ INSTRUCTIONS CAREFULLY BEFORE STARTING INSTALLATION. ON MODELS WITH DEF TANK, SELECT A FLAT, LEVEL AREA FOR INSTALLATION. MAY REQUIRE CUTTING.

1. Start the installation under the Driver/Left side of the vehicle. Locate the 5 tabs along the bottom edge of the body, (pinch weld). Mounting Brackets will bolt to the 1st, 2nd, 4th and 5th mounting tabs, **(Figure 1)**. Directly above each tab is a top mounting location on the side of the rocker panel. Hold a Bracket up in place to help determine the mounting holes to use.
2. Determine the correct procedure for your model year and each Bracket location.

Bottom mounting location on the edge of the pinch weld.

Flat tab on pinch weld with factory installed weld nut:

Thread hex bolt into weld nut from the backside-down to clear paint from threads.

Flat tab on pinch weld with hole:

Select (1) 8mm Clip Nut. Slide the Clip Nut over the tab with the nut facing up behind the tab, **(Figures 2 & 3)**. Line up threaded nut with hole in the tab. Repeat for each mounting location.

Locate top mounting location on the back side of the rocker panel.

Models with factory installed threaded insert in rocker panel:

Thread 8mm Hex Bolt into threaded insert to clear paint as required, (**Figures 2 & 3**).

Large and small hole in side of body panel:

Remove the rubber plug from the larger hole, (**Figure 4**). Select (1) 8mm Clip Nut. Slide the Clip Nut into the larger hole. Line up the threaded nut with the smaller hole.

3. Select (1) Driver/Left Mounting Bracket. Attach the Mounting Bracket to the Clip Nuts and/or the factory threaded holes with (2) 8mm Hex Bolts, (2) 8mm Lock Washers and (2) 8mm Flat Washers, (**Figure 5**). Do not tighten hardware.
4. Repeat **Steps 1—3** to attach (3) Mounting Brackets to the Driver/Left side.
5. Select the Driver/Left Ambush Side Step. Attach the Side Step to the front Faces of the Mounting Brackets with (8) 10mm Hex Bolts, (16) 10mm Flat Washers and (8) 10mm Nylon Lock Nuts, (**Figure 6**). Do not tighten hardware
6. Move to the Passenger/Right side of the vehicle. Determine if the vehicle is equipped with a plastic diesel exhaust fluid (DEF) tank, (**Figures 7 & 8**).

Models without DEF tank, skip to Step 7.

Models with DEF tank: The tank sits close to the side of the body. With specialized tools, the Passenger/Right Front Upper and Lower Mounting Brackets can be installed but room is very limited. Determine model year of vehicle before proceeding.

Up to 2016 models:

It may be easier to drop the tank down to access the inner side of the body panel for upper bracket installation. Tank will not need to be removed, only dropped down for access to mounting location.

IMPORTANT: If tank is full, it will be very heavy and assistance is highly recommended to avoid injury or damage to the vehicle or the tank. It is recommended that installation is performed when the DEF tank is low on fluid before dropping the tank.

- a. On models with plastic lower tray under the tank, remove the (3) hex bolts attaching the tray to the frame, (**Figure 7**), and remove the tray.
- b. Release the tank filler hose. Release the plug for the sending unit on the top of the tank.
- c. Support the tank with a floor jack. Place a smooth flat surface, (wooden block for example), between the floor jack and the tank to avoid damaging the plastic tank. Do not push up on the tank; only support the weight of the tank with the jack.
- d. Remove the (2) bolts securing the tank straps to the vehicle, (**Figure 8**). Tilt the straps to release from the brackets. Slowly lower the tank until the top of the tank is almost visible. Use blocks or stands to support the tank while installing the Front Upper and Lower Brackets.
- e. Proceed to **Step 7**.

On 2017 models and on:

- a. If necessary, remove the (4) hex bolts attaching plastic cover to DEF tank, (**Figure 9**) and remove plastic cover for better access. **NOTE:** On 2017-on 2500/3500 models, only remove plastic cover from DEF tank. **Do not lower DEF tank** and proceed to **Step 7**.
7. Locate the first tab on the edge of the pinch weld. Select the Upper Bracket, (**Figure 10**). Repeat **Steps 2 & 3** to attach the Passenger/Right Front Upper Mounting Bracket to the side of the rocker panel, (**Figure 11**). Do not tighten hardware.
8. Line up the hole in the bottom of the Upper Bracket with the hole in the tab on the pinch weld.
 - a. **Models with a weld-nut:** Slide the Bracket over the weld-nut. Attach the Lower Bracket to the bottom of the body and weld-nut with (1) 8mm Hex Bolt, (1) 8mm Lock Washer and (1) 8mm Flat Washer, (**Figures 11 & 14**). Do not tighten hardware.
 - b. **Models with flat tab and hole:** Insert the 8mm Bolt Plate down through the hole in the Upper Bracket and tab. Attach the Lower Bracket to the bottom of the body and Bolt Plate with (1) 8mm Flat Washer and (1) 8mm Nylon Lock Nut, (**Figures 12 & 13**). Do not tighten hardware.
9. Secure the front of the Lower Bracket to the Upper Bracket with (1) 8mm Hex Bolt, (1) 8mm Lock washer and (1) 8mm Flat Washer, (**Figure 15**). Do not tighten hardware.
10. Repeat **Steps 1—3** to attach the remaining (3) Mounting Brackets to the Passenger/Right rocker panel.

11. For 2017 2500/3500 DEF tank models: Locate the 2nd mounting location along the bottom edge of the body, (pinch weld), (**Figure 1**). Hold the DEF cover in place and mark the 2nd Bracket location onto the cover, (**Figure 16A**). Use a sharp knife or hacksaw blade to carefully cut a slot in the plastic cover to clear the 2nd Bracket, (**Figure 16B**). Remove as little plastic as possible.
12. Repeat **Step 5** to attach the Passenger/Right Ambush Side Step.
13. Once the Sidebar has been attached and all hardware fully tightened, reinstall the DEF tank and cover, if equipped, as described in **Step 6**.
14. Do periodic inspections to the installation to make sure that all hardware is secure and tight.

To protect your investment, Do not use any type of polish or wax that may contain abrasives that could damage the finish. Mild soap may be used also to clean the Running Boards.

Driver/Left Side Installation Pictured

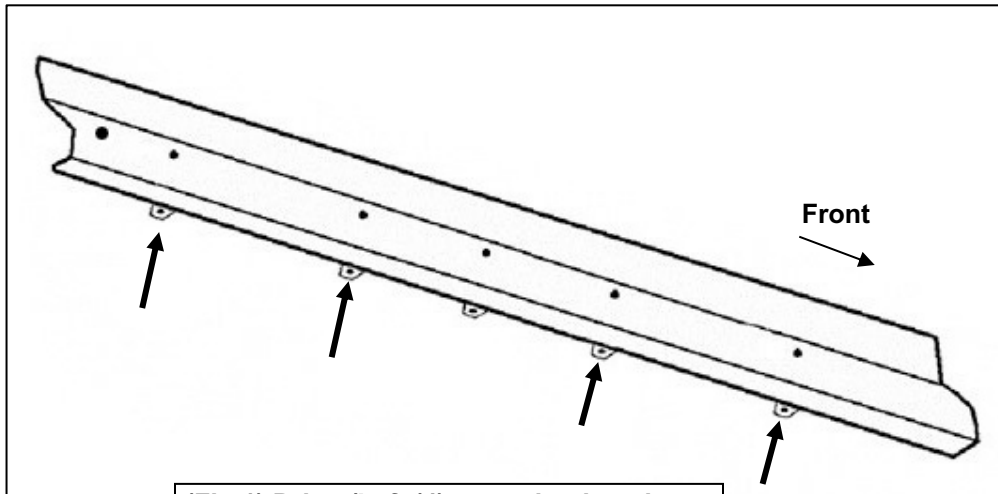

(Fig 1) Driver/Left (4) mounting locations

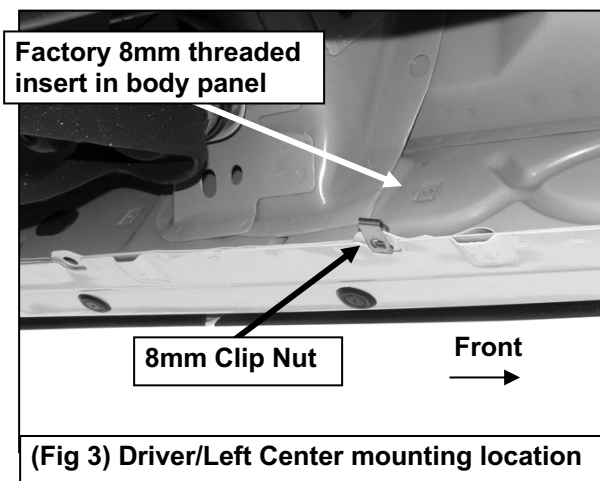

(Fig 3) Driver/Left Center mounting location

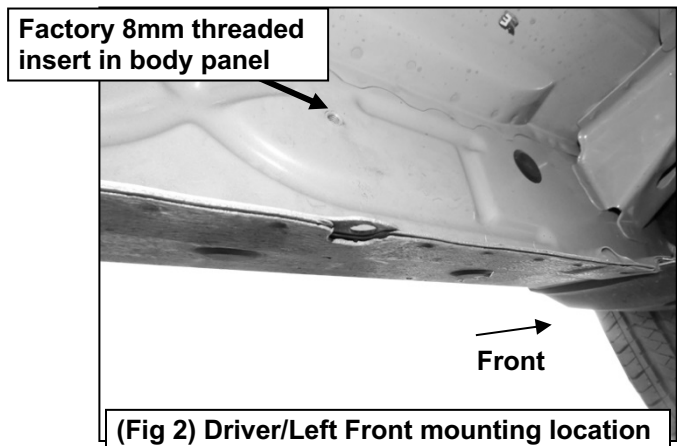

(Fig 2) Driver/Left Front mounting location

Driver/Left Side Installation Pictured

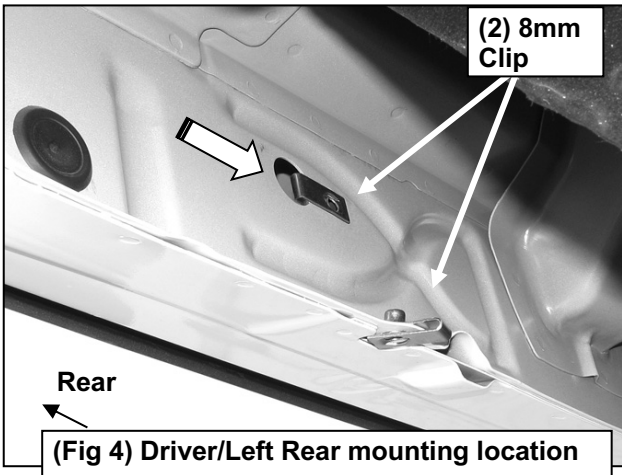

(Fig 4) Driver/Left Rear mounting location

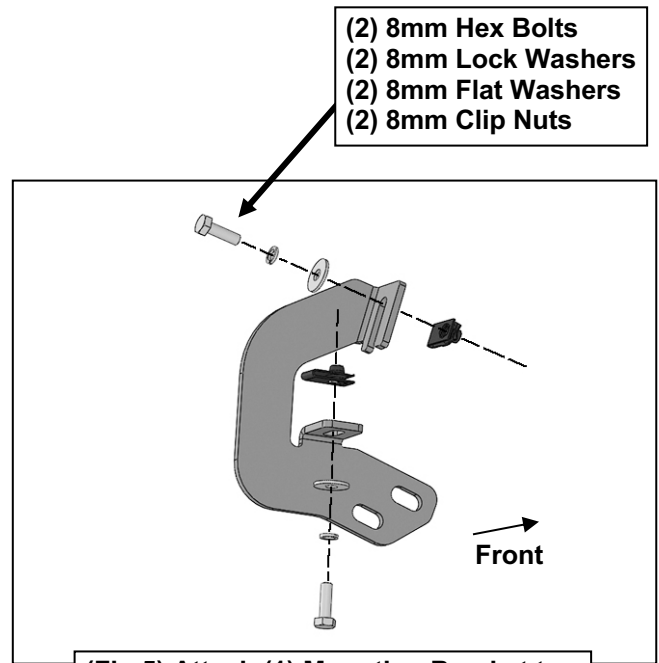

(Fig 5) Attach (1) Mounting Bracket to the Driver/Left front mounting location

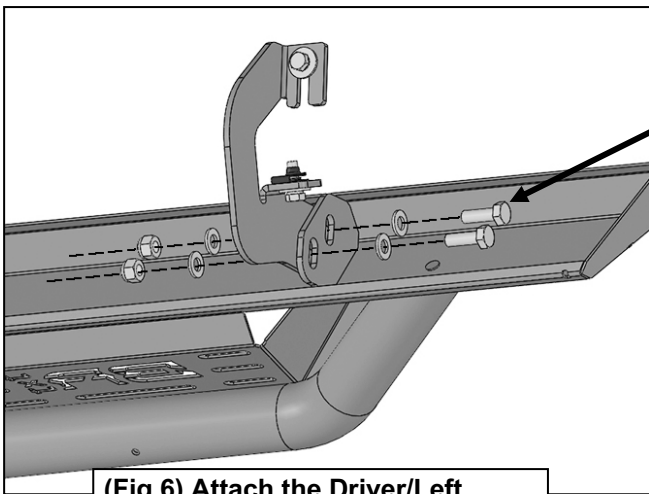

(Fig 6) Attach the Driver/Left Sidebar to the Mounting Brackets

Passenger/Right Front Installation Pictured

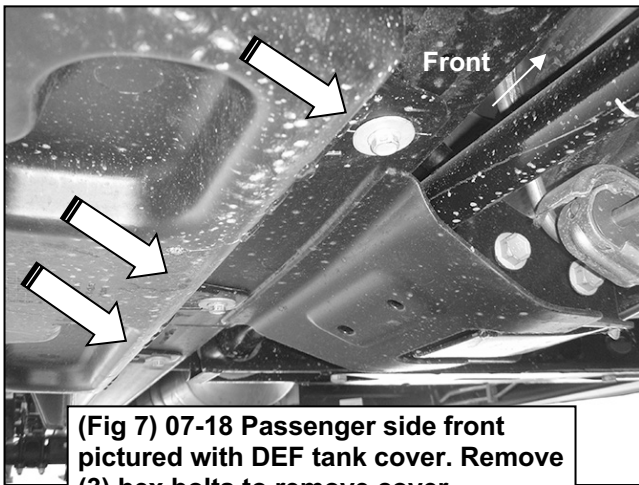

(Fig 7) 07-18 Passenger side front pictured with DEF tank cover. Remove (3) hex bolts to remove cover

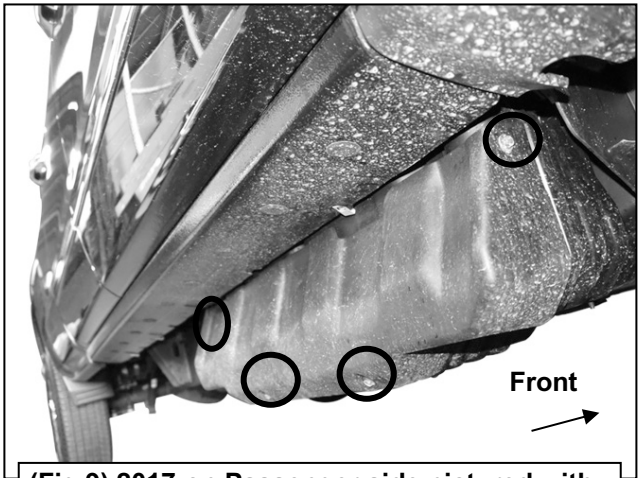

(Fig 9) 2017-on Passenger side pictured with DEF plastic tank cover. If needed, remove (4) hex bolts to remove plastic cover.

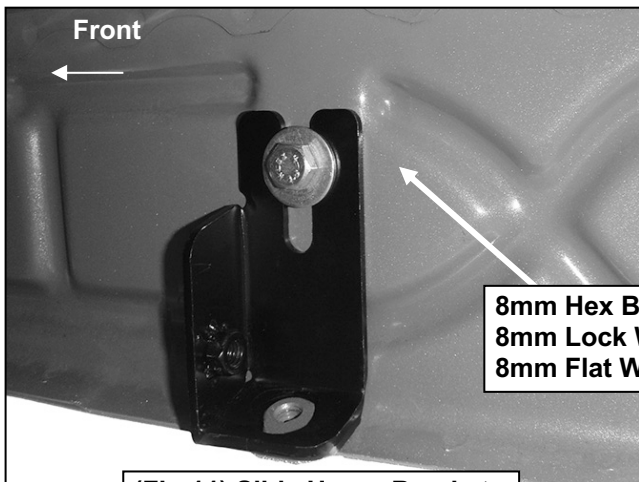

8mm Hex Bolt
8mm Lock Washer
8mm Flat Washer

(Fig 11) Slide Upper Bracket over weld nut if equipped

Remove (2) factory bolts to remove tank straps

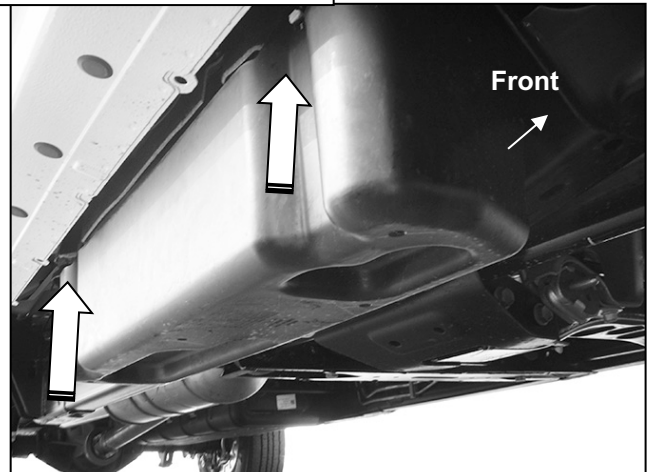

(Fig 8) 07-18 Passenger side DEF tank and cover

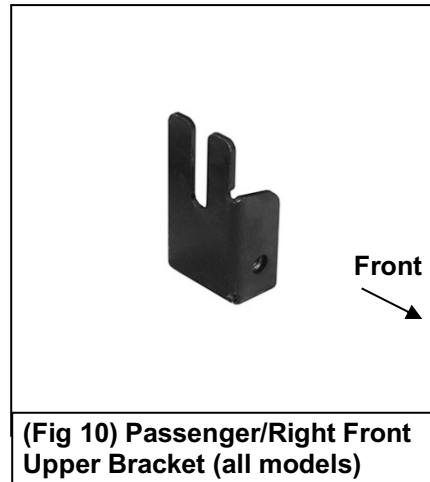

(Fig 10) Passenger/Right Front Upper Bracket (all models)



(Fig 12) 8mm

Passenger/right Front Installation Pictured

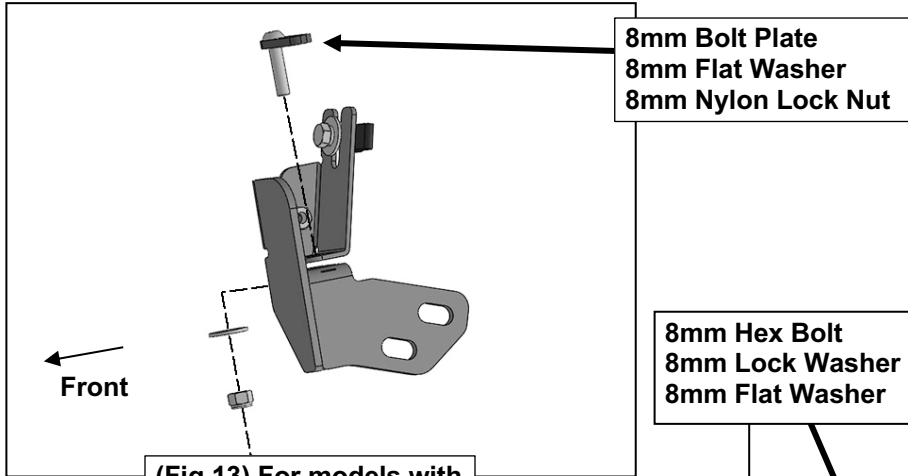

(Fig 13) For models with a hole in the pinch weld

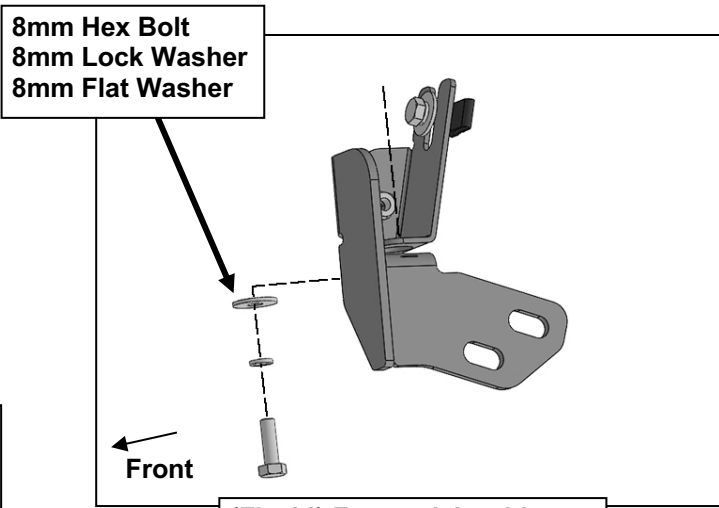

(Fig 14) For models with welded nut in the pinch weld

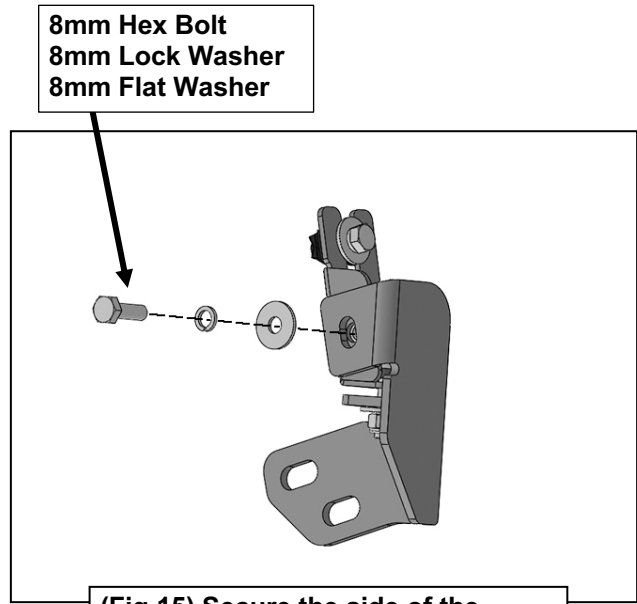

(Fig 15) Secure the side of the Lower Bracket to the Upper Bracket

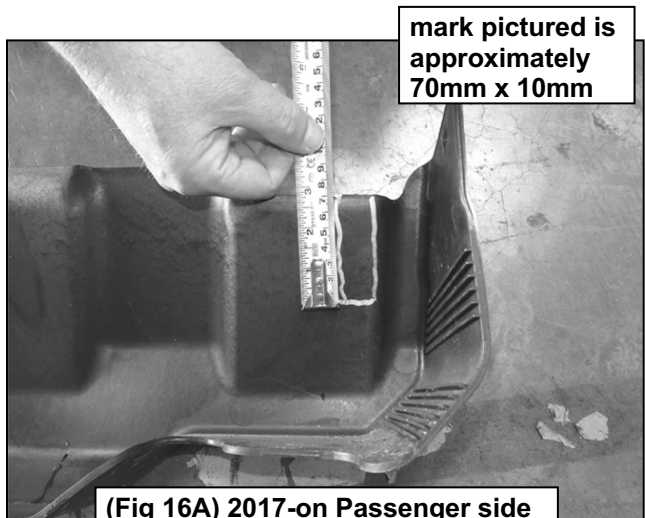

(Fig 16A) 2017-on Passenger side DEF cover marked for trimming

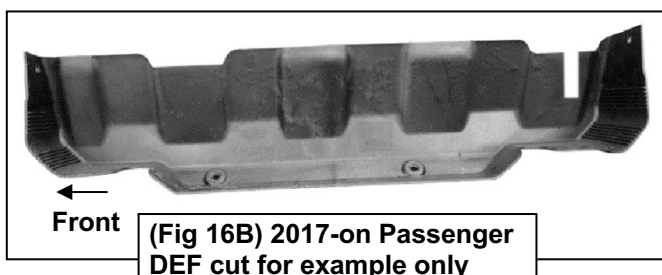

(Fig 16B) 2017-on Passenger DEF cut for example only