

2016-2023 TOYOTA TACOMA HILINE FRONT WINCH BUMPER PART#TC-19339

PARTS LIST:

1	BA Front Center Section Winch Bumper	2	10-1.5mm x 25mm Button Head Bolts
2	LED Center Light Bar L-Brackets	4	10mm x 20mm x 2mm Flat Washers
1	License Plate Bracket	2	10mm Nylon Lock Nuts
2	Plastic Plugs	3	8mm Bolt Plates
1	Edge Trim (2m length cut to fit)	2	8-1.25mm x 25mm Hex Bolts
2	12-1.75mm x 120mm Hex Bolts	7	8mm x 24mm x 2mm Flat Washers
2	12mm x 44mm x 4mm Large Spacer Washers	5	8mm Nylon Lock Nuts
2	12mm x 32mm x 3mm STD Flat Washers	3	8mm Hex Nuts
2	12mm Nylon Lock Nuts	1	6mm Wrench

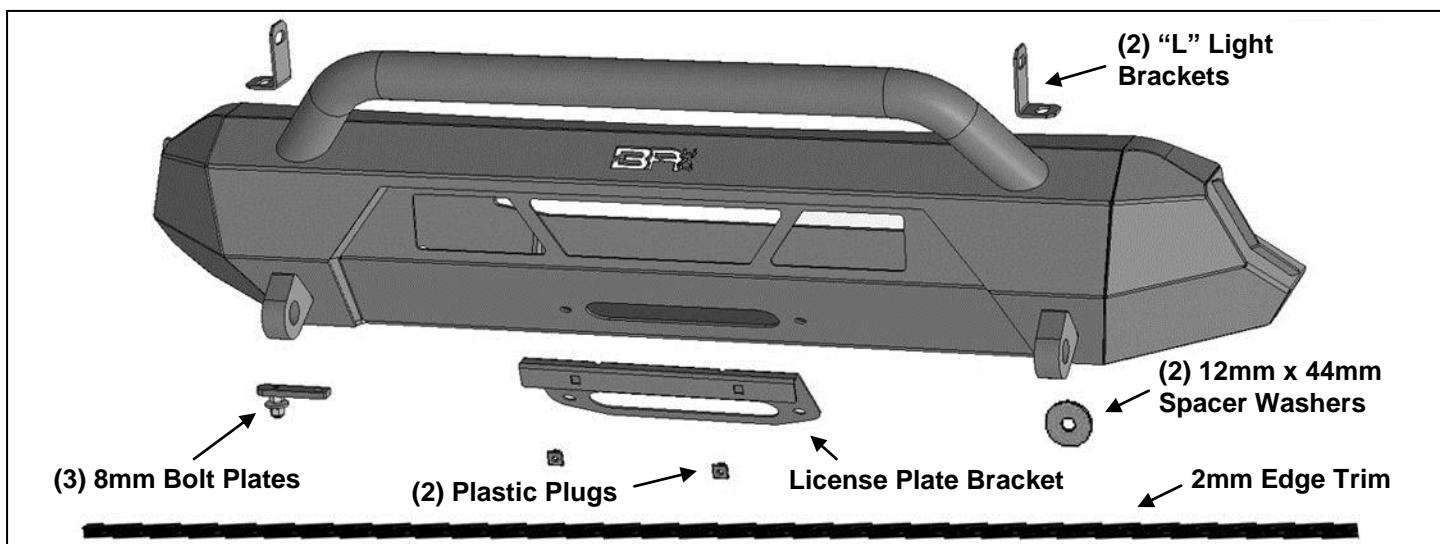

PROCEDURE:

REMOVE CONTENTS FROM BOX. VERIFY ALL PARTS ARE PRESENT. READ INSTRUCTIONS CAREFULLY BEFORE STARTING INSTALLATION. ASSISTANCE IS RECOMMENDED TO AVOID POSSIBLE INJURY OR DAMAGE TO THE VEHICLE. CUTTING OE FRONT BUMPER IS REQUIRED.

1. Remove the air dam from the bottom of the bumper and remove the skid plate, if equipped, (**Figure 1**).
2. Open the hood and remove the plastic cover from the top of the radiator and grille, (**Figure 2**). Next, carefully remove the plastic grille, (**Figure 3**).
3. Use removable tape, (masking tape for example), to cover the top and sides of the bumper cover in the approximate areas that will be cut, (**Figure 3—5**). Move to the top of the bumper and locate the approximate center of the bumper. Measure and place a mark 19-20mm (3/4") from the license plate bracket back toward the grille, (**Figures 6 & 7**). If there is no front license plate, measure from the bumper pad toward the grille. With a long straight edge, draw a straight line across the top of the bumper, (**Figure 6**). **NOTE:** Use a marking pen and draw onto the tape, not the painted finish.
4. Next, move to either side of the bumper and mark along the contour/bend line in the bumper to the top of the bumper, (**Figures 8 & 9**). Draw a short angled connecting line from the contour line to the long line across the top of the bumper. Repeat this Step to mark the remaining side of the bumper.
5. Remove the factory bolts along the inside of the driver/left front side of the wheel well to release the end of the fender flare, (**Figure 10**). Pull the flare straight out to release from the clips. Repeat to



INSTALLATION INSTRUCTIONS

release the passenger/right flare. **NOTE:** The fender flares do not need to be completely removed, only the front end of the flares attached to the bumper cover need to be released to remove cover.

6. On models with factory fog lights, unplug the harness leading to the bumper.
7. Remove the hardware attaching the plastic bumper cover at the top, ends and bottom, **(Figure 11)**. With assistance, pop the ends off of the inner clip and pull the bumper off and away from the vehicle, **(Figure 12)**. Set the plastic bumper cover on a soft, clean and flat surface.
8. Remove the plastic impact pad, aluminum cross bar and brackets from the frame, **(Figures 12 & 13)**. On models equipped with large bolt-on tow hook, **(Figure 13)**, remove tow hook from bottom of frame and it will not be reinstalled.
9. Determine if the vehicle is equipped with a power steering cooler, **models without cooler, proceed to Step 10.**

Models equipped with a power steering cooler:

- a. Remove the (2) bolts attaching the cooler to the top of the cross member, **(Figures 14 & 15)**.
 - b. Move to the passenger/right wheel opening. Release the clips and pull back the fender liner covering the side of the frame, **(Figure 16)**. Remove the hex bolt attaching the inner hose bracket to the top of the frame, **(Figure 17)**.
 - c. Select (1) 8mm Bolt Plate, **(Figure 18)**. With the bolt on the Bolt Plate facing up, reuse the factory bolt to attach the Bolt Plate to the top of the frame, **(Figure 19)**. Repeat to install the (2) Bolt Plates on the front crossmember in front of the radiator.
 - d. Rotate the Bolt Plates so that the bolt on each Bolt Plate is towards the rear.
 - e. Next, attach the cooler to the (2) Bolt Plates on the crossmember with (2) 8mm Flat Washers and (2) 8mm Nylon Lock Nuts, **(Figures 18—20)**. **NOTE:** If needed, use the included (2) 8mm Hex Nuts as spacers to raise the cooler up for additional clearance, **(Figure 18—20)**.
 - f. Repeat the previous Step to attach the passenger/right hose bracket to the Bolt Plate on the top of the frame, **(Figure 21)**.
 - g. Fully tighten the hardware on the Relocation Brackets and reattach the fender liner.
10. Remove the plastic center pad from the bumper cover, **(Figure 22)**.
 11. Use a sharp knife or hacksaw blade to carefully cut along the previously marked lines, **(Figure 23)**. **IMPORTANT:** For best fit, leave an extra 1/4" – 1/2" of material when cutting to make any adjustments at the end of the installation as necessary.
 12. Reinstall the cut plastic bumper cover. Select the Body Armor Center Bumper. Hold the Bumper up in place to check the fit of the Bumper against the cut plastic bumper cover and trim cover as necessary for best fit. Do not install the Body Armor Bumper at this time, only check the fit against the plastic bumper cover. Once all trimming is completed, remove any rough edges along the cut and cover the cut edge of the bumper cover with the included Edge Trim, **(Figure 24)**. Cut the Edge Trim to fit as required, **(Figure 25)**. Reattach the fender flares and plug in fog light wiring harness at this time.
 13. Next, move the Body Armor Front Bumper to a stable, clean and flat surface.
 14. **Center LED light installation** (sold separately).
 - a. Select (2) "L" Light Brackets, **(Figure 26)**. Use the provided (2) 8mm x 25mm Hex Bolts, (4) 8mm x 24mm Flat Washers and (2) 8mm Nylon Lock Nuts to attach the "L" Brackets to the mounting tabs on the back of the Bumper. Leave hardware loose.
 - b. Attach the LED light assembly to the "L" Brackets.
 - c. Adjust the light as necessary and tighten hardware.
 - d. Follow the instructions included with the light to connect the wire harness to the vehicle.
 15. **Winch installation** (sold separately).
 - a. Attach the winch to the center mounting plate on the back of the Bumper.
 - b. With assistance, hold the Bumper with winch up in position on the vehicle to check for clearance. Adjust or modify vehicle for clearance as necessary but do not install Bumper.
 - c. Attach cable guide (sold separately) to front of Bumper. **NOTE:** If front license plate is required, insert the included License Plate Bracket between the Bumper and the cable guide. Insert (2) Plastic Plugs into the square holes in the Bracket for license plate.

- d. Follow instructions packaged with winch to install winch and connect electrical system.
- 16. License Plate Bracket alone**, (Bumper install without winch).
- Attach License Plate Bracket to Bumper with the included (2) 10mm Button Head Bolts, (4) 10mm Flat Washers and (2) 10mm Nylon Lock Nuts, **(Figure 27)**.
 - Insert (2) Plastic Plugs into the square holes in the Bracket for license plate.
- 17.** With assistance, position the Bumper Assembly up to the frame bracket studs. Temporarily support the weight of the Bumper. **WARNING:** To avoid possible injury or damage to the vehicle, do not proceed until the bumper is fully and safely supported.
- 18.** Reuse the (6) factory flange nuts to attach the Bumper Assembly to the studs, **(Figures 28 & 29)**. Leave hardware loose at this time.
- Check fitment of Bumper and the trimmed plastic bumper cover. Trim plastic cover as required. Level and adjust the Bumper as needed and tighten all (6) factory hex nuts.
- 19.** Next, insert (1) 12mm x 120mm Long Hex Bolt with (1) 12mm x 44mm Large Spacer Flat Washer through the large hole in the back of the lower crossmember and out through the winch tray. Secure the winch tray to the bolt with (1) 12mm x 32mm STD Flat Washer and (1) 12mm Nylon Lock Nut, **(Figure 30—32)**. Repeat to attach the passenger/right side of the winch tray to the frame. Fully tighten hardware at this time.
- 20.** Reinstall the Grille and top plastic cover, **(Figure 23)**.
- 21.** Reinstall the skid plate, if equipped.
- 22.** Do periodic inspections to the installation to make sure that all hardware is secure and tight.

To protect your investment, Do not use any type of polish or wax that may contain abrasives that could damage the finish. Mild soap may be used to clean the Bumper assembly.

Driver/left side Installation Pictured

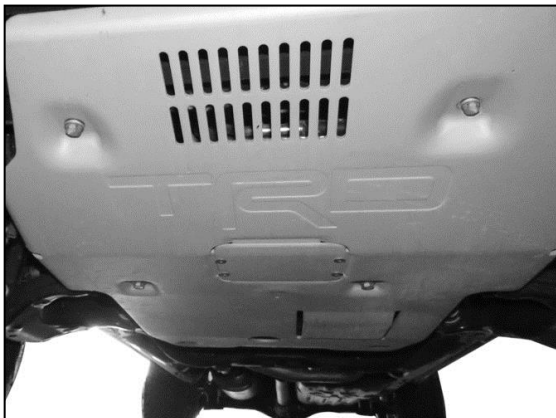

(Fig 1) Remove Skid Plate and air dam, if equipped

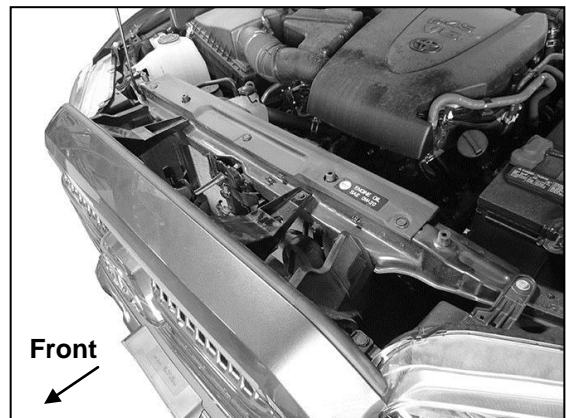

(Fig 2) Remove the plastic cover from the top of the radiator. Remove grille assembly

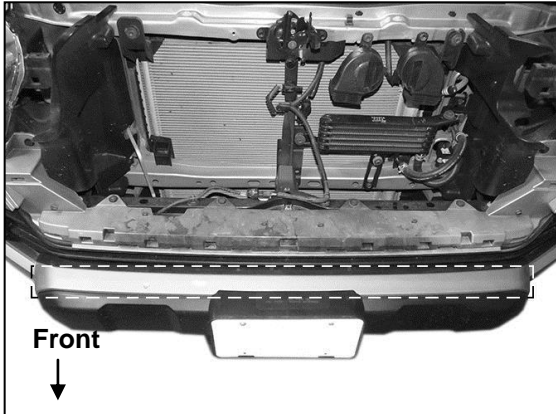

(Fig 3) Cover the top of the bumper with removable tape (masking tape for example)

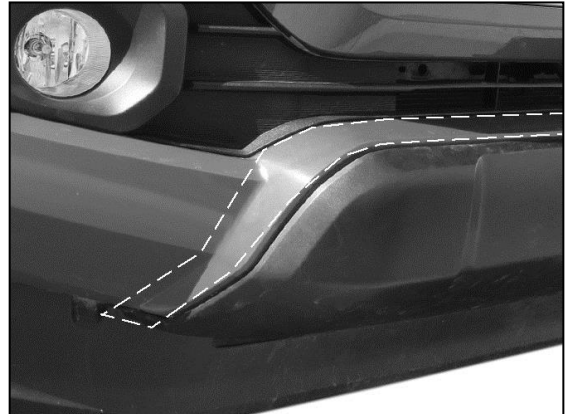

(Fig 4) Cover the sides of the bumper with removable tape (masking tape for example)



(Fig 5) Cover the sides of the bumper with removable tape (masking tape for example)

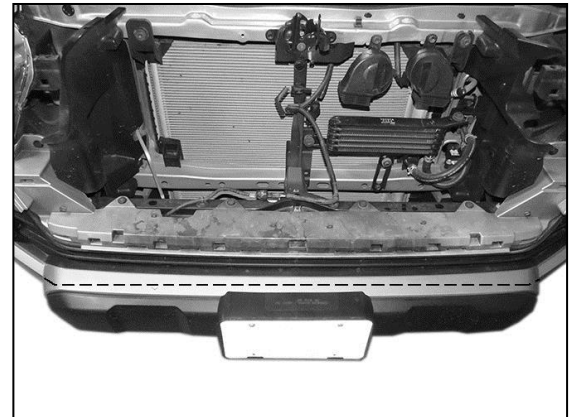

(Fig 6) Locate the approximate center of the bumper. Measure 3/4" (20mm) from the front edge of the bumper to the center (see Fig 7). Draw a straight line from side to side across the top of the bumper

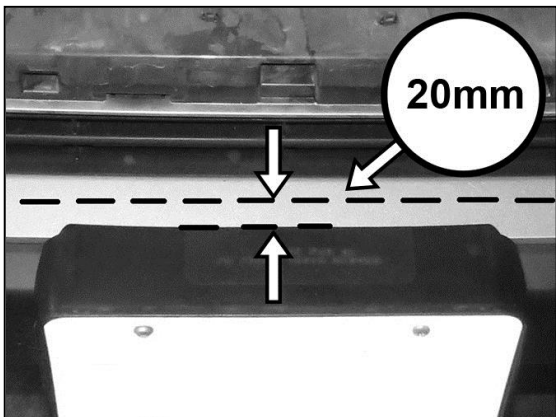

(Fig 7) Measure 3/4" (20mm) from the front edge of the bumper to the center (see Fig 6). Draw a straight line from side to side across the top of the bumper

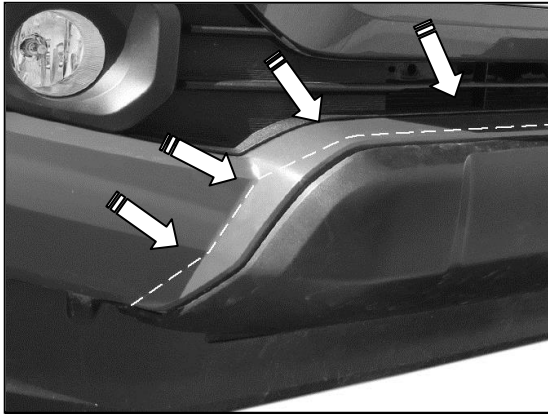

(Fig 9) Repeat Fig 8 to mark a cut line along the bend lines in the bumper. Passenger/right side pictured

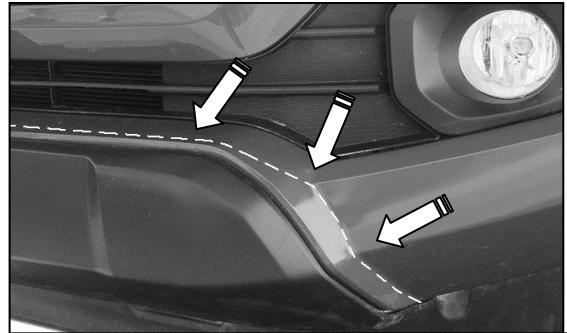

(Fig 8) Mark a cut line along the bend lines in the bumper. Connect the line drawn on the top of the bumper (Figs 6 & 7) with the lines in the bends (arrows). Driver/left side pictured



(Fig 11) Grille Removed. Remove factory bumper bolts along the top and bottom of bumper cover

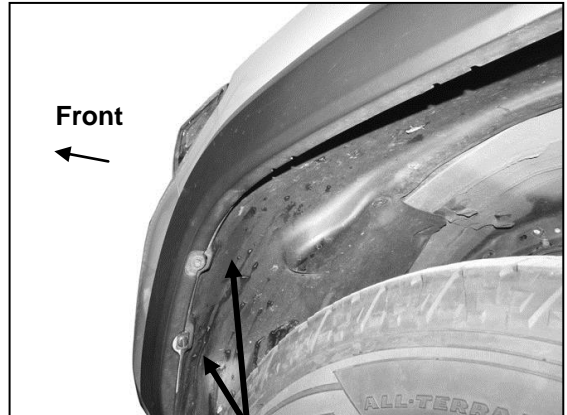

(Fig 10) Remove the factory bolts along the inside of the wheel well to release the driver/left front side Fender Flare

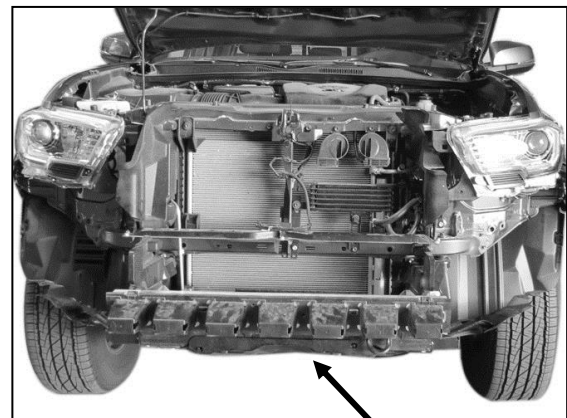

(Fig 12) Remove plastic impact bumper, aluminum crossbar and brackets from the end of the frame.

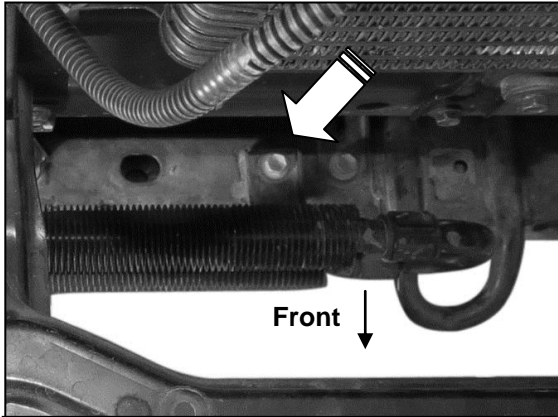

(Fig 14) Remove the bolts attaching the cooler to the top of the crossmember, if equipped

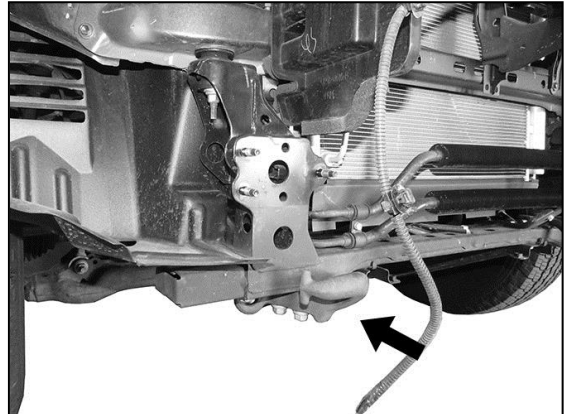

(Fig 13) Remove optional factory tow hook if equipped

NOTE: Bolt Plates are used to relocate the cooler, if equipped, up and back to the rear to increase clearance for the winch mounting plate on the Bumper.

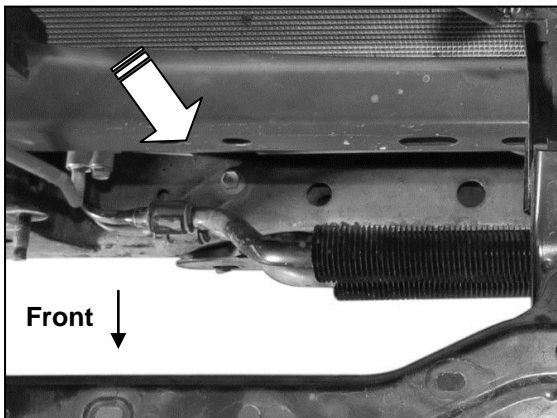

(Fig 15) Remove the bolts attaching the cooler to the top of the crossmember

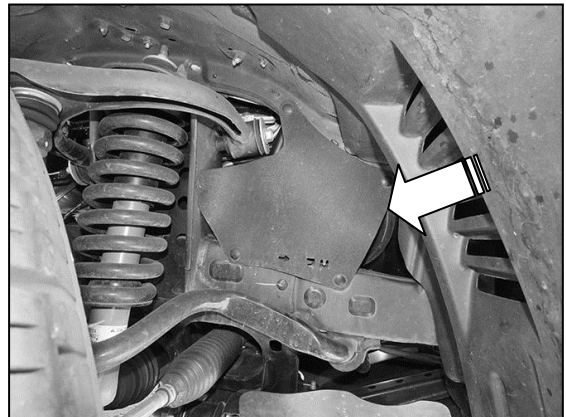

(Fig 16) Pull back passenger/right inner fender liner (arrow)

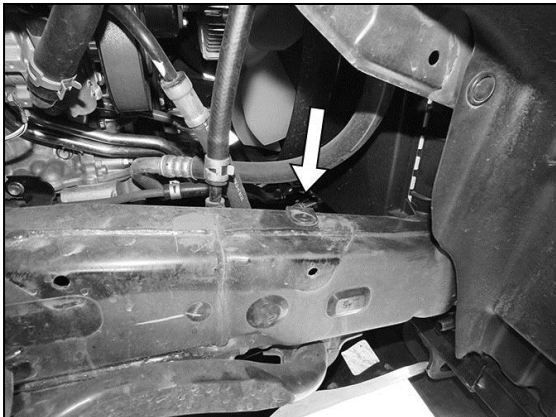

(Fig 17) Remove hex bolt attaching bracket to top of frame (arrow)



(Fig 19) Passenger/right side of cooler relocated towards the radiator (arrow)

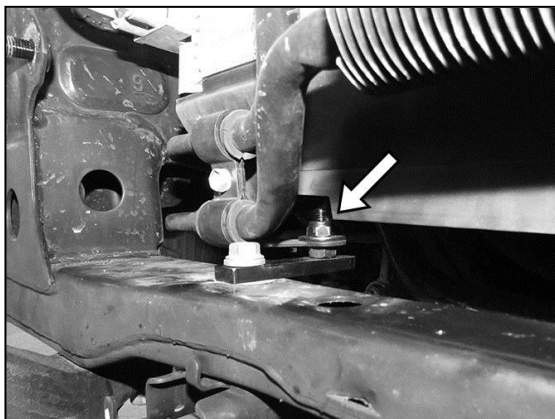

(Fig 20) Passenger/right side of cooler relocated towards the radiator (arrow)

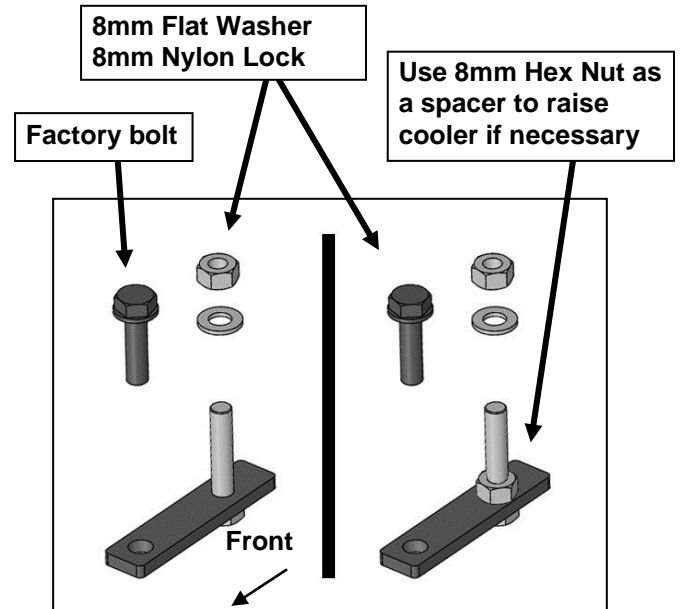

(Fig 18) Reuse the factory bolt to attach Bolt Plate to the cross member. Slide the cooler over the bolt on the Bolt Plate and secure with provided hardware

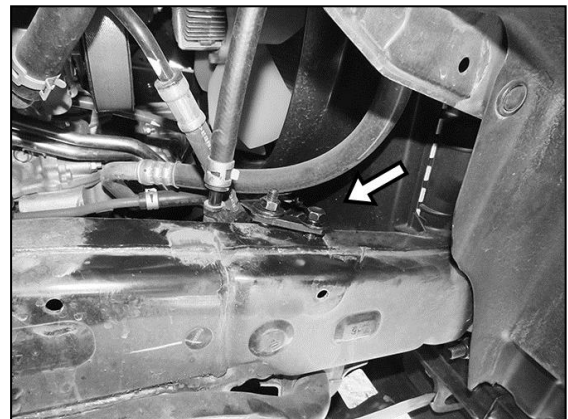

(Fig 21) Relocation Bracket installed on passenger/right side top of frame (arrow). Reinstall fender liner



(Fig 22) Remove center pad from bumper cover

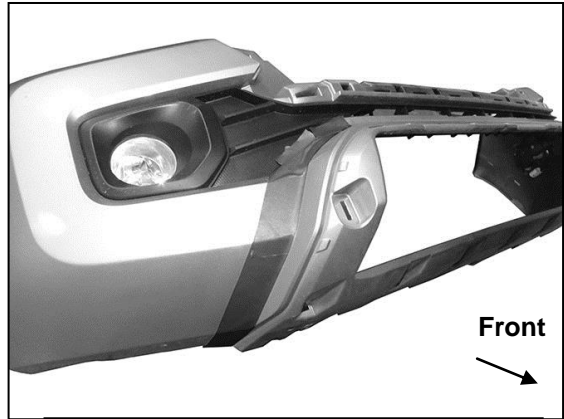

(Fig 23) Bumper prepped for cutting

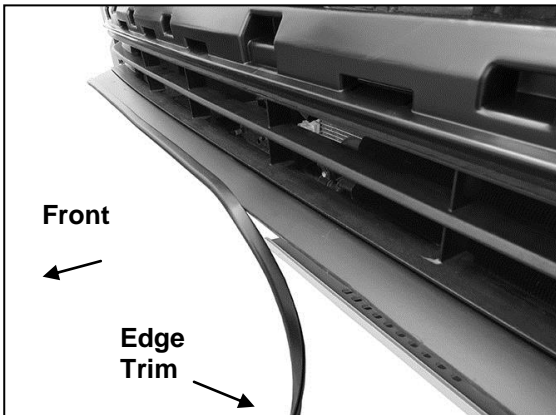

(Fig 24) Reinstall Bumper and push Edge Trim over cut edge. Cut Trim to fit

8mm x 25mm Hex Bolt
(2) 8mm Flat Washers
8mm Nylon Lock Nuts

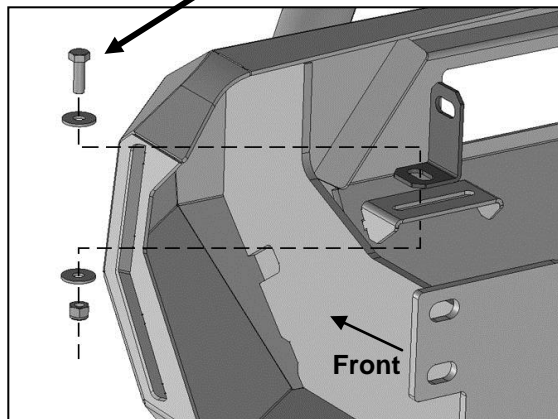

(Fig 26) Attach "L" Light Bracket to tab on back of Bumper (installation optional-light not included)

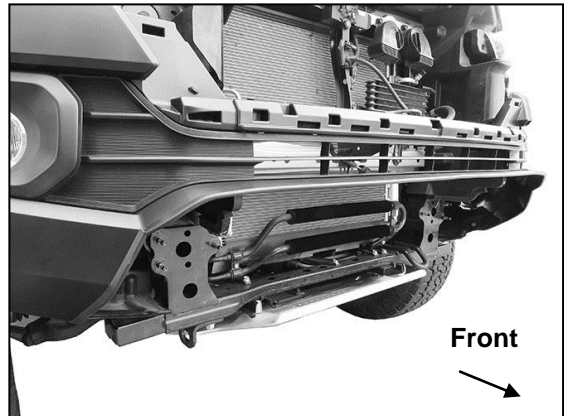

(Fig 25) Bumper cut and Edge Trim applied. Hold Bumper up and in place to check fit and trim as necessary before installing Edge Trim

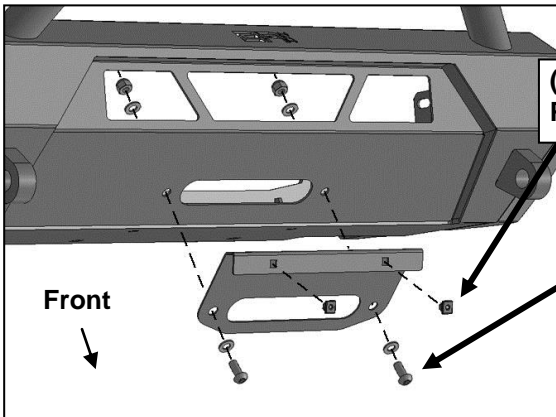

(2) Plastic Plugs

(2) 10mm Button Head Bolts
(4) 10mm Flat Washers
(2) 10mm Nylon Lock Nuts

Front
↓

(Fig 27) Attach License Plate Bracket and cable guide (not included) to Bumper

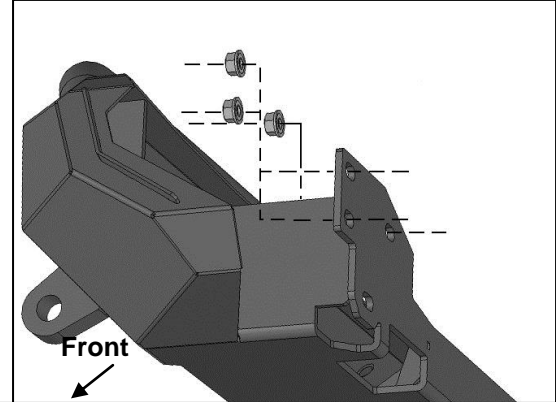

Front
↓

(Fig 28) Reuse the factory hex nuts to attach the Bumper to the frame (driver/left side illustrated)

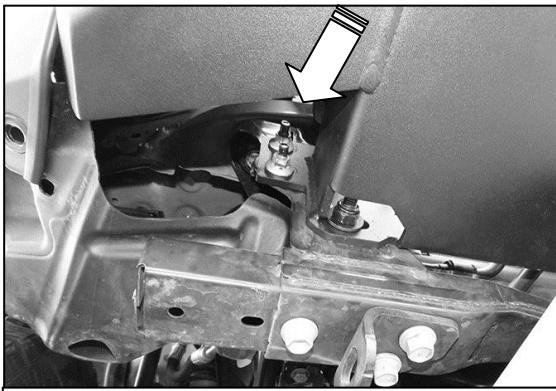

(Fig 29) Reuse the (3) factory hex nuts to attach the Bumper to the end of the frame (passenger/right pictured)

12mm x 32mm STD Flat Washer
12mm Nylon Lock Nut

12mm x 120mm Long Hex Bolt
12mm x 44mm Spacer Washer

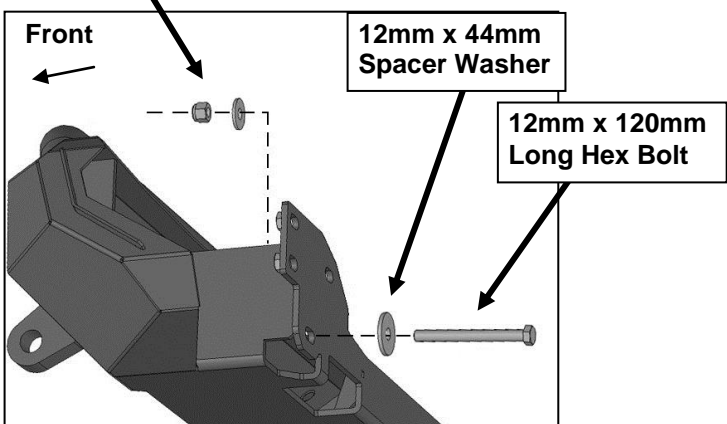

Front
←

12mm x 44mm Spacer Washer

12mm x 120mm Long Hex Bolt

(Fig 30) Insert Hex Bolt with Spacer Washer through back of frame and then Winch Tray

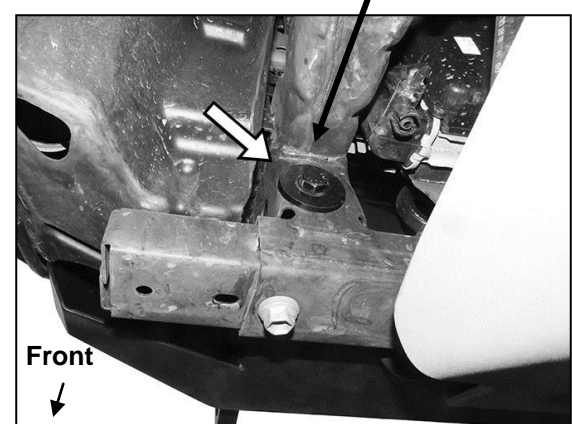

Front
↓

(Fig 31) 12mm x 120mm long Hex Bolt with Spacer Washer (arrow) pictured from behind crossmember (Driver/left side pictured)

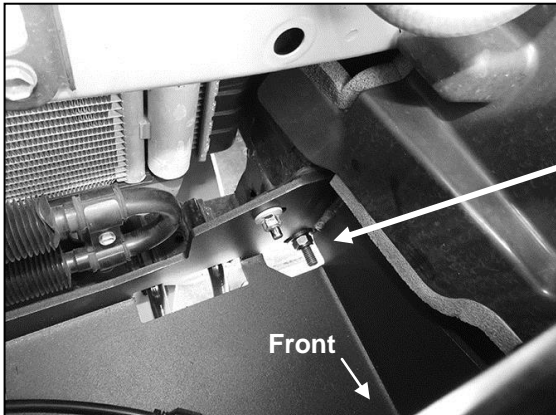

12mm x 32mm STD Flat Washer
12mm Nylon Lock Nut

(Fig 32) Attach winch tray to end of frame
(Driver/left side pictured from above)



(Fig 33) Check fit of Bumper to plastic
and trim as necessary. Reinstall grille
and top cover



Complete Installation (light
and cable guide not included)