

**** Inspect bumper and all parts prior to installation. Contact us at 951-808-0750 for missing parts.**

Hardware list:

QTY 8	M12X1.75X40mm
QTY 8	M12 Washer
QTY 8	M10X1.5X25mm
QTY 12	M10 Washer
QTY 4	M10X1.5 nut

**Removing Factory bumper:**

- 1 Remove factory grill from truck by removing two screws from top.



- 2 Remove all fasteners from wheel well top of bumper fascia, and from bottom of bumper fascia. If equipped with driving lights disconnect wiring harness at this time.
- 3 Remove front bumper fascia. If installing factory driving lights I new front bumper, remove at this time.



- 4 Remove aluminum front bumper structure and retain factory hard ware.
- 5 Remove two fascia supports, one on each side of vehicle.
- 6 Remove end pieces from crash bar and factory tow hook.



Bumper Installation for TC-19335:

We recommend you have help with lifting of the rear bumper to avoid injury or damage to bumper and vehicle.

- 1 Install winch plate using factory hardware used for aluminum bumper. (If installing a winch install at this time.

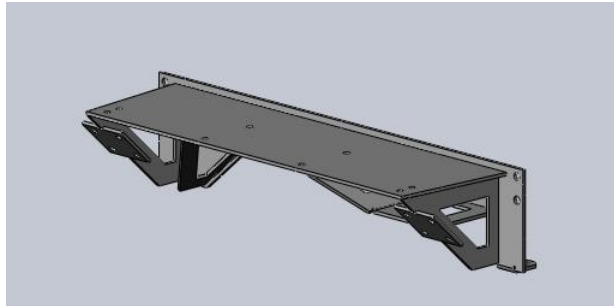

- 2 Install Front bumper and d-ring to winch plate using M 12 hardware. Leave loose at this time.

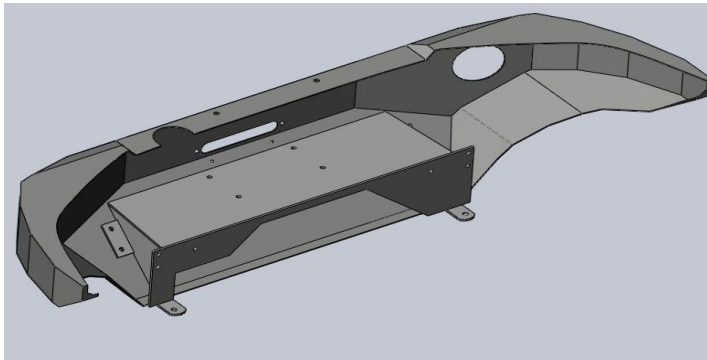

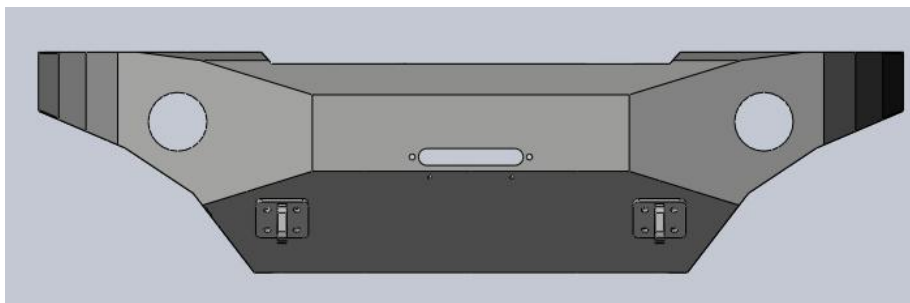

- 3 Check alignment to body and tighten all hardware.
- 4 Mount auxiliary lights at this time. If reusing factory lights use supplied bracket to mount lights to light tabs.
- 5 Cut inner plastic fender as needed to clear front tires.

Note: Recheck all hardware after the first couple hundred miles. It is advised to inspect the bumper and hardware periodically.



WARRANTY POLICY & PROCEDURE

Contact your Body Armor 4x4 Distributor or Body Armor 4x4 directly regarding any issue prior to removing product from vehicle. If it appears said product is warrantable, you will be given a Return Authorization Number (RA #) and asked to return said product freight pre- paid. The RA # must appear on the outside of the carton/box of any returned product. Unauthorized returns will be refused. RA # must be given by Body Armor 4x4 in advance of return.

BODY ARMOR LIMITED LIFETIME WARRANTY

Body Armor 4x4 (BA) warrants to the original purchaser that these products will be free from defects in material and workmanship prior to shipping and/or installation for the life of the product. This non-transferable limited lifetime warranty does not cover damage or impairment in any part due to misuse, improper installation, accident or contact with on-road or off-road hazards, product modification, improper or inadequate cleaning and/or maintenance. All other warranties and representations express or implied are hereby disclaimed, including fitness for merchantability and buyer's intended use or purpose.

BA products are built and sold for highway and off-road use. The original purchaser assumes all risks as to the selection, suitability and performance of all goods and products purchased.

BA's sole and exclusive obligation under this warranty shall be to repair or replace the item(s) and their discretion and BA will not issue any credit or refund to the consumer. Proof of purchase is required on all warranty claims. BA may require pictures to diagnose the warranty claim and may require the product(s) be returned if determined by BA to be necessary. If a return is required then a RGA number will be issued by BA. Any item arriving to BA without a valid

RGA number will be refused and sent back. Upon evaluating the RGA and no valid warranty claim is made, the RGA will be returned to the consumer at their expense or disposed by BA after 60 days. BA will not be responsible for incidental charges such as removal, installation, shipping costs or lost during transit. Any items that are ordered in error, refused or cancelled are not considered a valid warranty claim and cannot be returned to BA.

WARRANTY PROCESS

Contact an authorized BA dealer to initiate warranty process. Authorized dealers must contact BA to assist in evaluating the warranty claims. Valid warranties will have a RGA issued. Once issued the dealer will request the product be returned to BA facilities. Products purchased through an authorized BA dealer will be refunded and/or credited by that BA dealer.

Warranty contact: orders@bodyarmor4x4.com

Return address: Body Armor 4x4, 1050 N. Vineyard Ave. Ontario CA, 91764, P: 951-808-0750

FINISH WARRANTY

The finish is warranted to be free of defects for a period of 3 years from date of purchase. Product(s) that have been abused, altered, incorrectly installed or used in competition are void of said warranty. Surface rust, pitting or discoloration is a direct result of improper maintenance is not covered by this warranty. It is the responsibility of the owner to preserve and maintain the finish of their product(s). In areas where high concentrations of road salts and other corrosive agents are used, rust or damage to the finish may occur if BA product(s) are not properly maintained. Lack of proper maintenance in these areas may void the finish warranty. See below for routine maintenance tips and recommendations.

**PRODUCT CARE AND MAINTENANCE**

Textured coat finished should be cleaned ONLY with a mild soap on a damp sponge.

BA recommends wiping down the product with a light coat of lubricate (i.e. WD40) periodically to maintain its luster.

DO NOT apply polish or wax that requires buffing for removal as this may damage the finish.

DO NOT coat the product with any type of shine such as Tire Shine or glossy aerosol or gel. This can cause discoloration, staining or bubbling.