

## 2007-2018 Wrangler Front Bumper Full Width PART #JK-19531

### PARTS LIST:

1	Full Width Front Bumper Assembly	8	12mm x 24mm x 2.5mm Flat Washers
1	Top Hoop	8	12mm Lock Washers
1	Winch Fairlead Mount Plate	4	10-1.5mm x 30mm Hex Bolts
2	Side Spacers	8	10mm x 20mm x 2mm Flat Washers
2	12mm Nut Plates	4	10mm Lock Washers
2	12-1.75mm x 75mm Hex Bolts	4	10mm Hex Nuts
8	12mm x 25mm Hex Bolts		

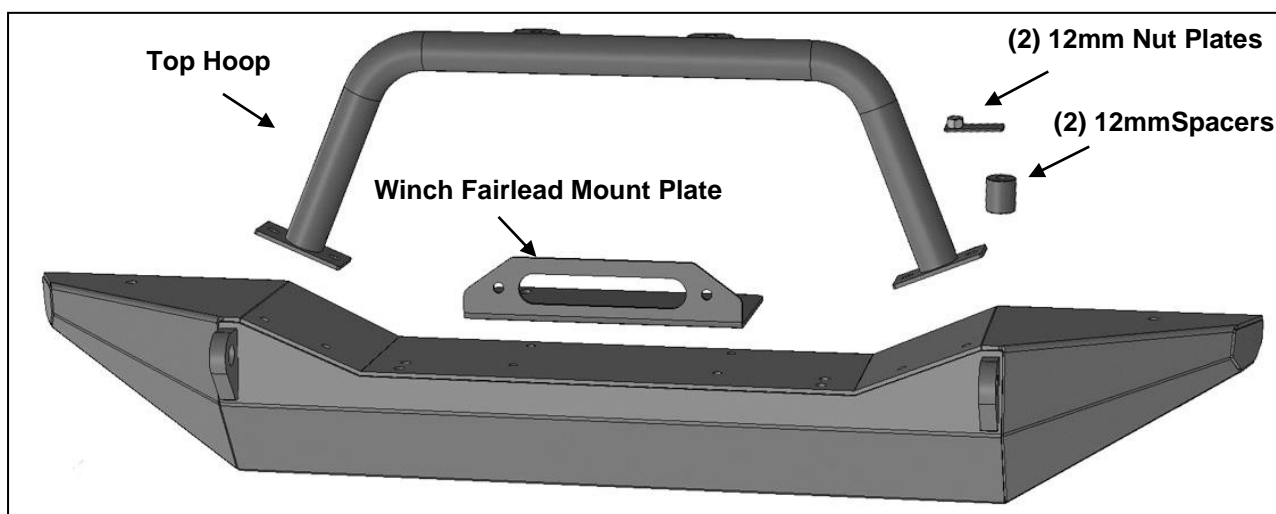

### PROCEDURE:

**REMOVE CONTENTS FROM BOX. VERIFY ALL PARTS ARE PRESENT. READ INSTRUCTIONS CAREFULLY BEFORE STARTING INSTALLATION. ASSISTANCE IS RECOMMENDED. FACTORY FOG LIGHT ASSEMBLIES CANNOT BE INSTALLED. DRILLING MAY BE REQUIRED.**

1. Start under the front bumper and remove the plastic lower splash guard or skid plate, **(Figure 1)**. **NOTE:** Splash guard or skid plate cannot be reinstalled.
2. On models with factory fog lights, unplug wiring harness leading to the bumper before removing bumper. Secure harness to frame and cover ends of wire. Remove cover from top of frame behind bumper.
3. With assistance, remove the front bumper hardware and bumper, **(Figures 2 & 3)**.
4. If installing Hoop Light Bar (optional), attach Light Bar to top of Bumper with the included (4) 10mm x 30mm Hex Bolts, (8) 10mm Flat Washers, (4) 10mm Lock Washers and (4) 10mm Hex Nuts, **(Figure 4)**. Also attach tow hooks, (not included), to top of Bumper. **NOTE:** It may be easier to install Winch, (not included), and Fairlead Bracket before installing Bumper.
5. With assistance, hold the Bumper assembly up to the end of the frame. Line up the Mounting Plates in the back of the Bumper with the mounting holes in the bumper mounting plates on the end of the frame. Attach the Bumper to the frame with (8) 12mm x 25mm Hex Bolts, (8) Lock Washers and (8) 12mm Flat Washers, **(Figure 5)**. **IMPORTANT:** On some model years, the mounting holes in the frame brackets may require drilling to clear the 12mm Hex Bolts. Use a 1/2" drill bit to open up the mounting holes for the 12mm hardware as necessary. Leave hardware loose at this time.
6. Move to the driver/left side of the frame. Determine procedure for your model year, **(Figure 6)**:

**2007-09 models**

- a. Select (1) 12mm x 75mm Long Hex Bolt and (1) 12mm Spacer. Insert the Hex Bolt through the hole in the mounting plate on the back of the Bumper. Insert the 12mm Spacer between the mounting plate and the bracket welded to the side of the frame, **(Figure 7)**.
- b. Insert (1) 12mm Nut Plate up and into the side of the frame and onto the Hex Bolt, **(Figures 7 & 8)**. Leave loose at this time.
- c. Repeat previous Steps to attach the passenger/right side of the Bumper and Spacer to frame.

**2010-2018 models.**

- a. Hold Spacer in place between side of frame and mounting plate. Line up Spacer with hole in plate on back of Bumper.
  - b. Mark the location of the hole in the mounting plate and Spacer onto the side of the frame, **(Figure 6 & 7)**. **NOTE:** Mark should be between the existing holes in the side of the frame.
  - c. Drill a 1/2" hole through the outer bracket welded to the side of the frame at the marked location. Do not drill into or through the main part of the frame.
  - d. Select (1) 12mm x 75mm Long Hex Bolt and (1) 12mm Spacer. Insert the Hex Bolt through the hole in the mounting plate on the back of the Bumper. Insert the 12mm Spacer between the mounting plate and the side of the frame at the drilled hole, **(Figure 7)**.
  - e. Insert (1) 12mm Nut Plate up and into the side of the frame and onto the Hex Bolt. Use tape, (masking tape for example), to extend end of Nut Plate, if necessary, to reach up to the drilled hole, **(Figure 7 & 8)**. Leave loose at this time.
  - f. Repeat previous Steps to attach the passenger/right side of the Bumper to the Spacer and frame.
7. Level and adjust as required. Once properly aligned, fully tighten all hardware.
  8. Do periodic inspections of the installation to make sure that all hardware is secure and tight.

**Driver/left Side Installation Pictured**

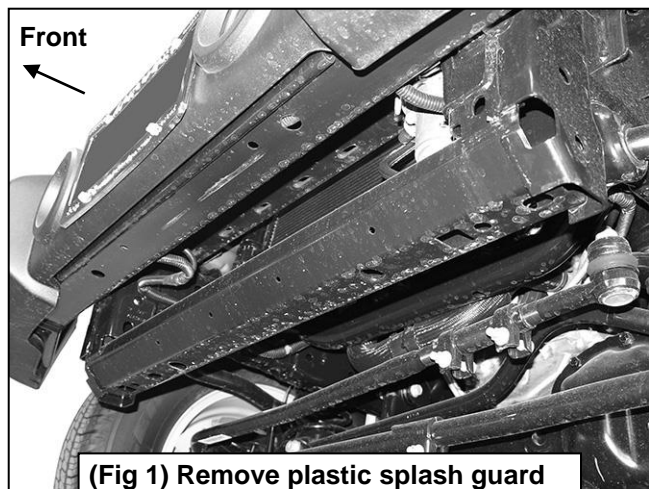

**(Fig 1) Remove plastic splash guard or skid plate from bottom of bumper**

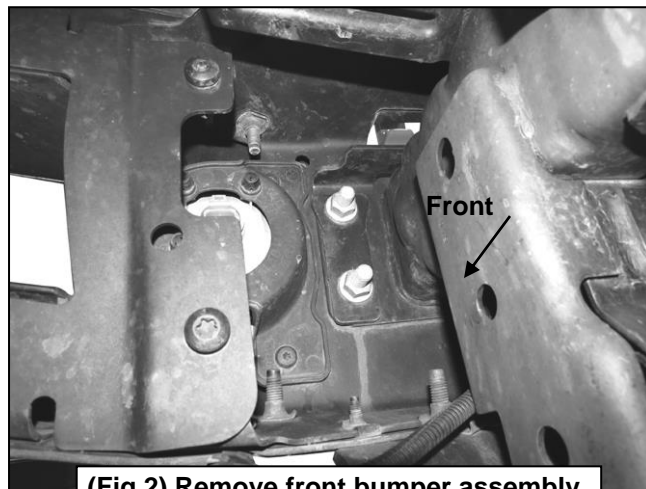

**(Fig 2) Remove front bumper assembly (2010-18 driver/left side pictured)**



(Fig 3) Front Bumper and splash guard removed. NOTE: Check (8) mounting bolt holes for fit, holes may need to be drilled to 1/2"

- (2) 10mm x 30mm Hex Bolts
- (4) 10mm Flat Washers
- (2) 10mm Lock Washers
- (2) 10mm Hex Nuts

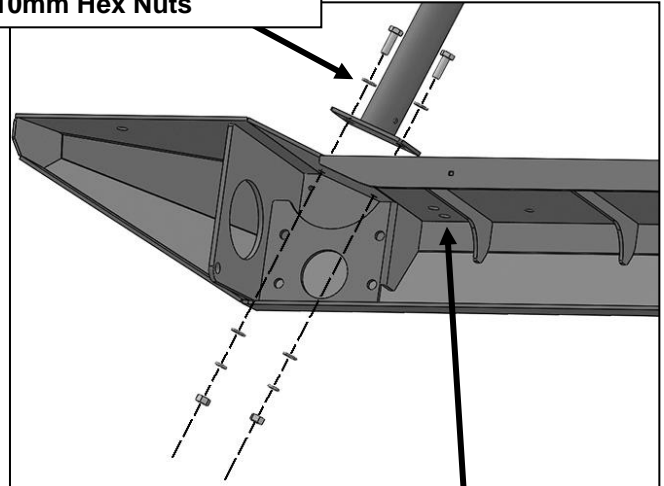

(Fig 4) Attach Top Loop (optional) and tow hooks (not included) to top of Bumper before installing.

NOTE: It may be easier to attach winch (optional-not included) to top of Fairlead Mount Plate and Bumper before installing Bumper

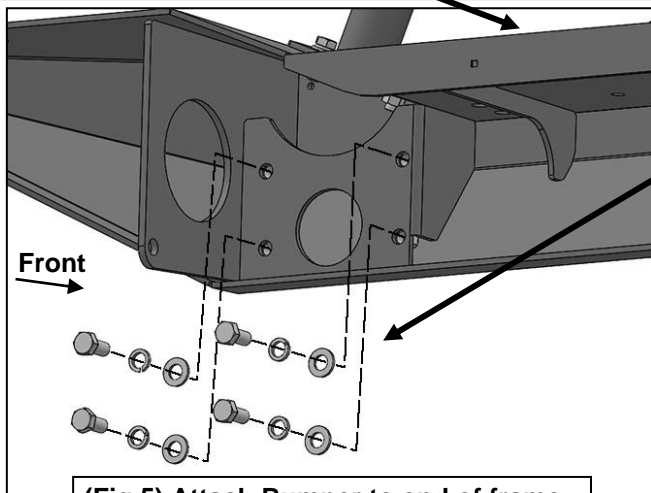

- (4) 12mm x 25mm Hex Bolts
- (4) 12mm Lock Washers
- (4) 12mm Flat Washers

(Fig 5) Attach Bumper to end of frame.



2007-09

2010-18

(Fig 6) Determine year of vehicle, 2010-18 models will require drilling 1/2" hole in bracket on outside of frame for support bolts

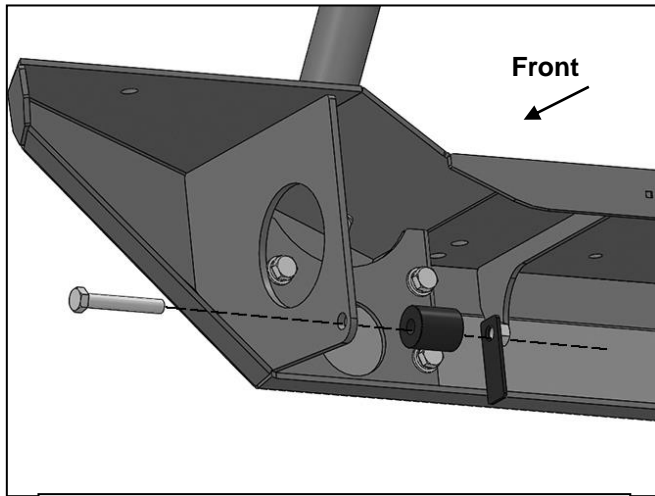

**(Fig 7) Insert 12mm Nut Plate up into bracket on outside of frame. NOTE: On 2010-18 models, use removable tape to extend the end of the Nut Plate to reach up to the hole drilled into the outer bracket**

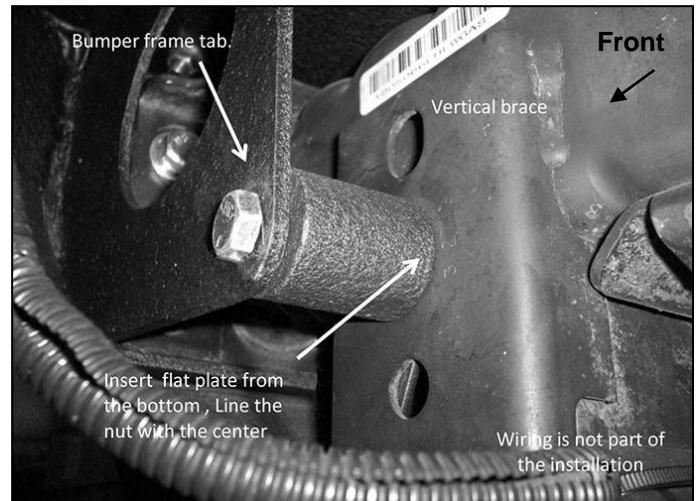

**(Fig 8) Driver/left outer Support Bolt and Spacer attached (2007-09 model pictured)**