



INSTALLATION INSTRUCTIONS

2018-2023 JEEP WRANGLER JL TIRE CARRIER SINGLE ACTION (FITS JL-2965/JL-2966 BUMPER) PART #5298

PARTS LIST:

1	Swing Arm	4	Bump Stop Spacer Plates
1	Tire Carrier Bracket	3	14mm Plastic Retainers (use with camera bracket)
1	Tailgate Base Bracket	2	12-1.75mm x 70mm Hex Bolts
1	Inner Camera Relocation Bracket	9	12-1.75mm x 35mm Hex Bolts
1	Camera Relocation Cover	18	12mm x 24mm x 2.5mm Flat Washers
1	Lower CHMSL (brake light) Bracket	4	12mm Lock Washers
1	Upper CHMSL (brake light) Bracket	7	12mm Nylon Lock Nuts
1	Rod End Adjuster Sleeve	2	8-1.25mm x 25mm Button Head Bolts
1	Right Hand Thread Rod End	2	8mm x 16mm x 1.6mm Flat Washers
1	Right Hand Thread Jam Nut (for Rod End)	2	8mm Lock Washers
1	Left Hand Thread Rod End	6	6-1.0mm x 25mm Button Head Bolts
1	Left Hand Thread Jam Nut (for Rod End)	4	6mm x 18mm x 1.6mm Large Flat Washers
4	12mm Rod End Spacers	4	6mm x 12mm x 1.6mm STD Flat Washers
1	Bolt-On Spindle	4	6mm Lock Washers
1	Small Upper Bearing	2	6mm Nylon Lock Nuts
1	Large Lower Bearing	3	2mm x 10mm Philips Head Screws
1	Lower Bearing Seal	3	2mm Hex Nuts
1	Castle Nut	1	Spindle Bearing Cover W-Logo
1	26mm x 45mm OD x 3mm Thrust Washer	1	4mm x 15mm Phillips Screw (use w/Bearing Cover)
1	8mm Set Screw (use with Castle Nut)	1	5mm Wrench
1	Lock Plate (use with Castle Nut)	1	4mm Wrench
2	Rubber Bump Stops		

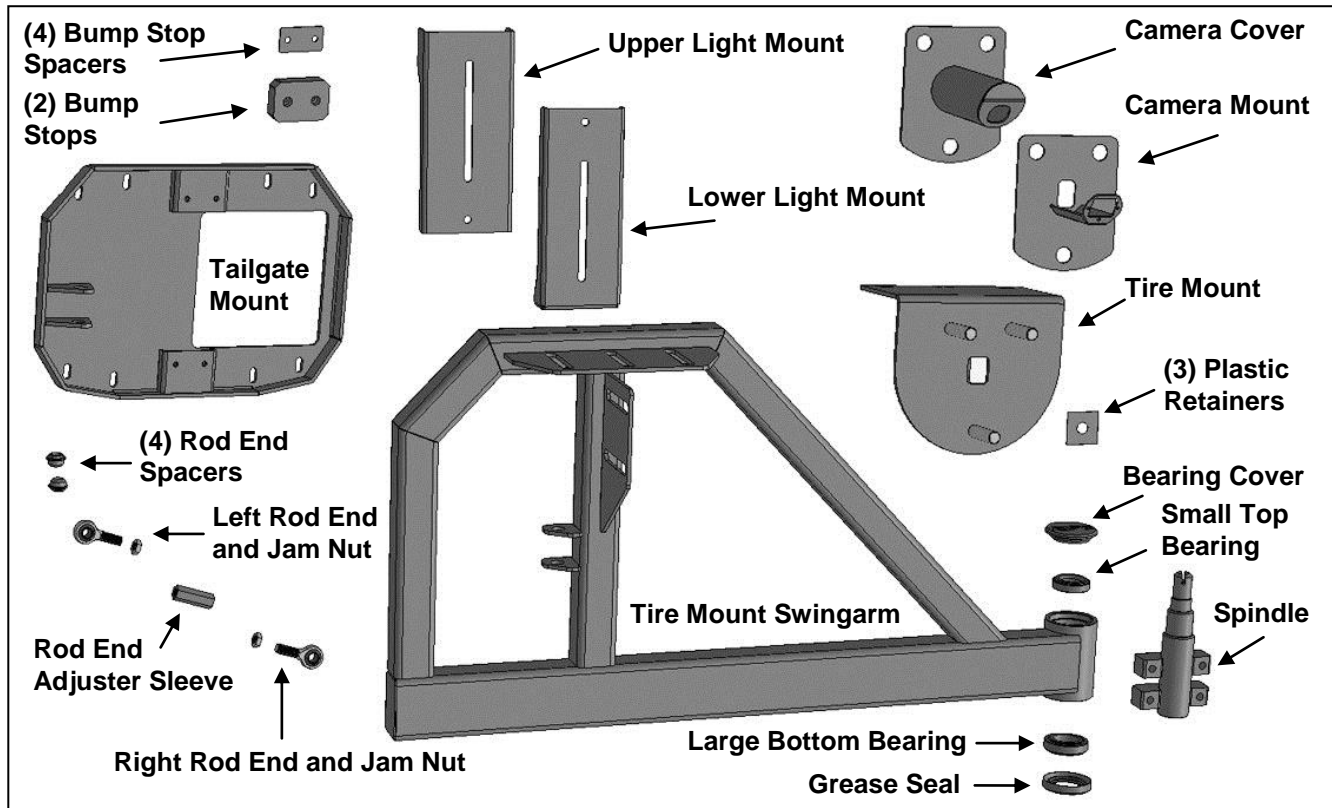

PROCEDURE:

REMOVE CONTENTS FROM BOX. VERIFY ALL PARTS ARE PRESENT. READ INSTRUCTIONS CAREFULLY BEFORE STARTING INSTALLATION. ASSISTANCE IS HIGHLY RECOMMENDED.

1. Open the tailgate and remove the large plastic cover from the back of the tailgate, **(Figure 1)**. Disconnect the wire harness leading to the CHMSL (3rd brake light) and the camera if equipped. Push the wire harness and grommet back through the tailgate, **(Figure 2)**.
2. Remove the spare tire and spare tire mount assembly with light and camera from the tailgate, **(Figures 2 & 3)**. Remove the left vent shutter assembly, **(Figure 3)**.
3. Select the Tailgate Mount. Reuse the (8) factory hex bolts to attach the Tailgate Mount to the tailgate, **(Figure 4)**.
4. Select (1) Right Hand Thread Rod End and (1) Right Hand Thread Jam Nut. Thread the Jam Nut all the way onto the Rod End, **(Figure 5)**. **VERY IMPORTANT:** The kit includes a Right Hand and a Left Hand thread Rod Ends and Jam Nuts. Only thread the Right Hand Thread Jam Nut by hand onto the Right Hand Thread Rod End. Thread the right hand threaded side of the center Adjuster Sleeve onto the Right Hand Rod End. Select the remaining Left Hand Rod End and Jam Nut. Thread the Jam Nut onto the Left Hand Rod End. Thread the Rod End into the left hand threaded side of the Adjuster Sleeve, **(Figure 5)**. Thread the Rod Ends into the Adjuster Sleeve an equal amount. Leave the Jam Nuts loose at this time.
5. Next, select (2) Rod End Spacers. Insert the Spacers into the tabs on the Tailgate Mount, **(Figure 6)**. Select the Adjuster Assembly from **Step 4**. Insert one end of the Adjuster Assembly between the Spacers and tabs. Attach the Adjuster to the Spacers and tabs with the included 12mm x 70mm Hex Bolt, (2) 12mm Flat Washers and 12mm Nylon Lock Nut, **(Figure 7)**. Do not fully tighten hardware.
6. Select (1) Bump Stop. Attach the Bump Stop to the pad on the Tailgate Mount with the included (2) 6mm x 25mm Button Head Bolts, (2) 6mm Lock Washers and (2) 6mm x 12mm STD Flat Washers, **(Figure 8)**. Repeat this Step to attach (1) Bump Stop to the remaining pad on the Mount. **IMPORTANT:**

- (4) Spacers have been included to align the Swing Arm with the Bumper, **(Figure 8)**. Final adjustment will be made after the Arm has been installed and adjusted, **(Figure 16)**.
7. Remove the hole plug from the top of the Bumper, **(Figure 9)**. Insert the Spindle up and between the Mounting Plate and back of the Bumper. Attach the Spindle to the Mounting Plate with the included (4) 12mm x 35mm Hex Bolts, (4) 12mm Lock Washers and (4) 12mm Flat Washers, **(Figures 9—11)**. Snug but do not fully tighten hardware at this time as minor adjustment may be necessary.
 8. Next, select the Swing Arm. Unwrap the large Lower Bearing assembly. Insert the Bearing Race into the bottom of the Swing Arm, **(Figure 12)**. Pack the Lower Bearing with grease (waterproof wheel bearing grease recommended, not included). Insert the Bearing into the Race in the Swing Arm. Select the Swing Arm Seal. Tap the Seal into the bottom of the Swing Arm over the Bearing, **(Figure 12)**.
 9. Unwrap the small Upper Bearing assembly. Insert the Bearing Race into the top of the Swing Arm, **(Figure 12)**. With assistance, carefully place the Swing Arm onto the Spindle. Pack the Upper Bearing with grease. Insert the Bearing into the Race in the top of Swing Arm. Place the Thrust Washer and Castle Nut over Spindle and Upper Bearing. Tighten the Castle Nut enough to seat Bearings but do not overtighten, **(Figure 13)**. Check Swing Arm for ease of movement and adjust Castle Nut to stop excessive movement as necessary. Once properly adjusted, slide the Castle Nut Lock Key down into the slot in the Spindle and Nut, **(Figure 14)**. Use the included Set Screw to keep the Lock Key in place in the end of the Spindle, **(Figure 14)**. Push Bearing Cap into the top of the Swing Arm. Secure Cap to Swing Arm with included 4mm Screw, **(Figure 15)**.
 10. Align and adjust the Swing Arm to the Bumper and fully tighten Spindle mounting hardware.
 11. Use the included Spacer Plates between the Tailgate Mount and the Bump Stops to adjust the Swing Arm as needed to line up with the tailgate and Bumper, **(Figure 8 & 16)**.
 12. Repeat **Step 4** to attach (2) Rod End Spacers and the Rod End on the Adjuster Assembly to the tabs on the back of the Swing Arm. Loosen Jam Nuts and turn Adjuster Sleeve to line up Rod End with holes in mounting tabs, **(Figure 16)**. Once adjusted, tighten Jam Nuts on Rod Ends. Also tighten hardware attaching the Adjuster Assembly to the Mount and Swing Arm.
 13. Select the Tire Carrier Mounting Bracket. Attach the Bracket to the top and left side of the tabs on the Swing Arm with (5) 12mm x 35mm Hex Bolts, (10) 12mm Flat Washers and (5) 12mm Nylon Lock Nuts, **(Figure 17)**. Do not fully tighten hardware at this time as adjustment may be required, **(Figure 18)**.
 14. Slowly open the tailgate and check for proper operation. Adjust the Adjuster Assembly length as needed and fully tighten Adjuster hardware, **(Figure 19)**. Close tailgate.
 15. Move the factory spare tire mount to a stable work area. Remove the screws attaching the inner wheel stud hub and camera mount to the back of the tire mount, **(Figure 20)**. Remove the camera from the end of the hub. Select the Inner Camera Relocation Bracket. Attach the camera to the end of the Bracket with the included (3) 2mm x 10mm Screws and (3) 2mm Hex Nuts, **(Figure 21)**. **IMPORTANT:** Do not overtighten the hardware or damage to the camera may result.
 16. Push the wire harness for the camera through the hole in the Tire Mount. Slide the Camera Bracket over the threaded studs in the Tire Mount, **(Figure 22)**. Slide Camera Cover over the Camera Bracket. Thread the included (3) 14mm Plastic Retainers onto the wheel bolts to help hold the Camera Mount Brackets in place, **(Figure 23)**.
 17. Select the Lower CHMSL Light Relocation Bracket, **(Figure 24)**. Attach the Bracket to the top of the Swing Arm with the included (2) 8mm x 25mm Button Head Bolts, (2) 8mm Lock Washers and (2) 8mm Flat Washers. Attach the Upper Light Relocation Bracket to the front of the Lower Bracket with the included (2) 6mm x 25mm Button Head Bolts, (4) 6mm x 18mm Large Flat Washers and (2) 6mm Nylon Lock Nuts, **(Figures 24 & 25)**.
 18. Disassemble the factory spare tire mount to remove the brake light and wiring harness, **(Figures 26 & 27)**. Reuse the factory hardware to attach the brake light to the top of the Upper Relocation Bracket, **(Figure 28)**.
 19. Reinstall the factory wire harness and camera harness through the Swing Mount and back through the tailgate. Plug the harness into the vehicle harness. Reinstall plastic cover.

- 20. With assistance, attach the spare tire to the tire mount studs. Adjust height of Light Relocation Bracket to clear tire and tighten hardware, (**Figure 29**). Adjust Tire Mount in or out as needed to properly support spare tire across Swing Arm. Tighten all hardware at this time.
- 21. Do periodic inspections to the installation to make sure that all hardware is secure and tight.

To protect your investment, do not use any type of polish or wax that may contain abrasives that could damage the finish. Mild soap may be used to clean Tire Carrier.

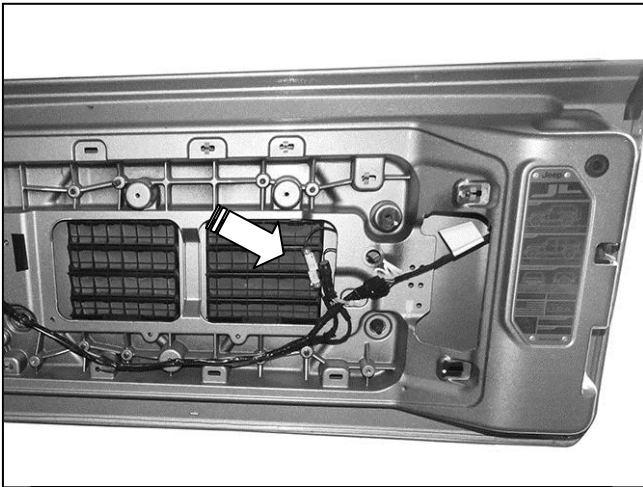

(Fig 1) Remove plastic cover from inside of tailgate. Disconnect wire harnesses leading to the camera and CHMSL (3rd brake light)

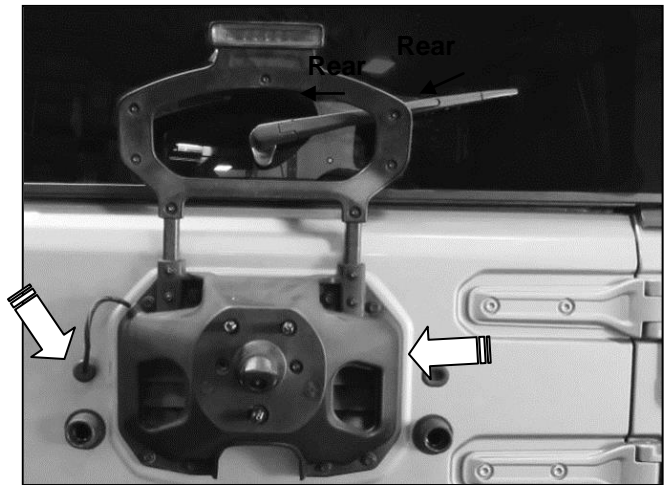

(Fig 2) Release rubber grommet (left arrow) and pull harness through hole in tailgate. Remove spare tire mount from outside of tailgate (arrow)

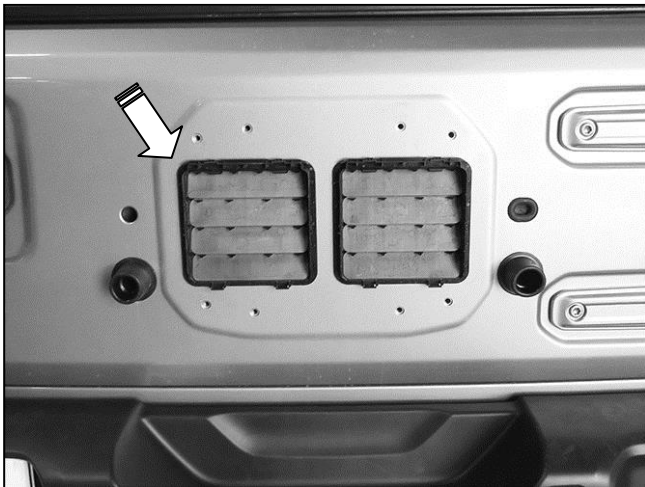

(Fig 3) Remove vent shutters from left side of tailgate (arrow)

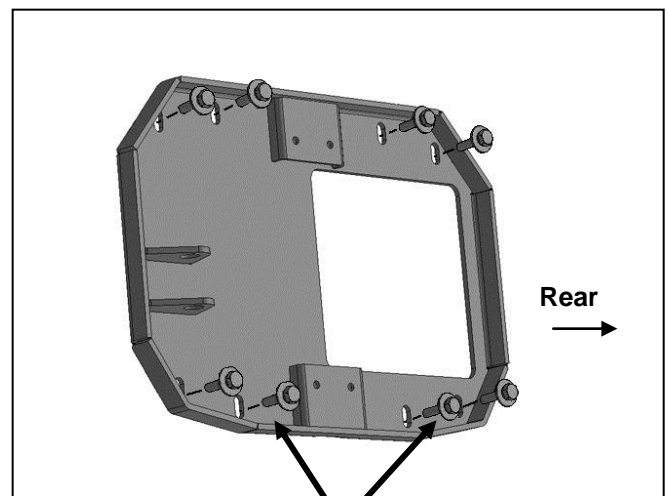

(Fig 4) Reuse factory hex bolts to attach the Tailgate Mount Bracket to the tailgate

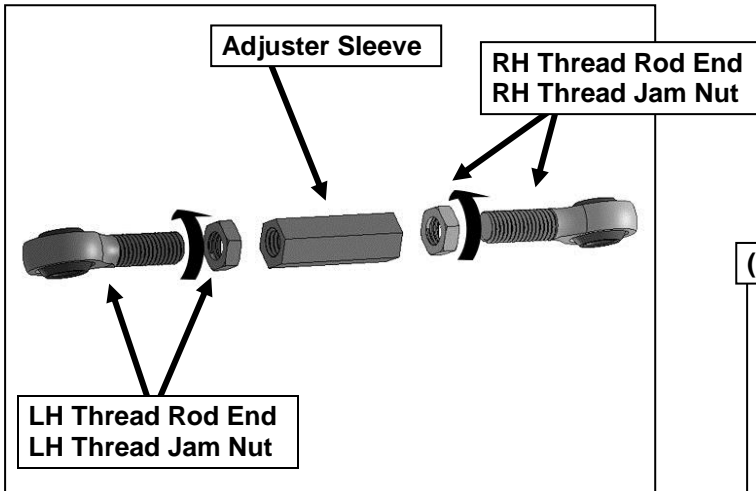

(Fig 5) Assemble the Swing Arm Adjuster assembly. **IMPORTANT:** Adjuster Sleeve, Rod Ends and Jam Nuts feature right hand and left hand threads. Do not mix hardware.

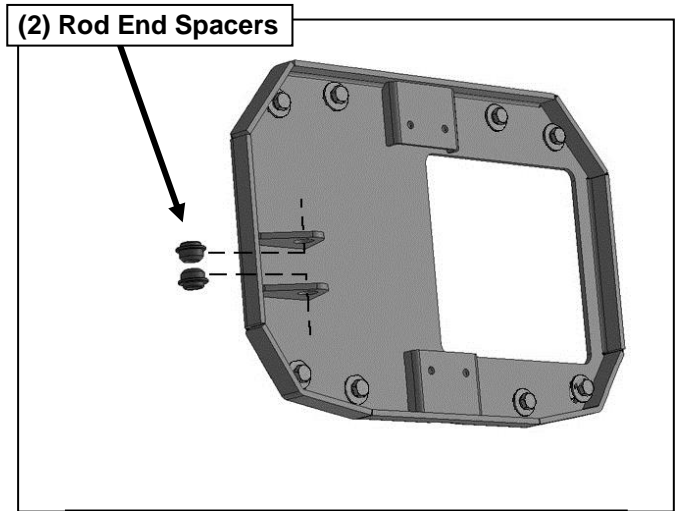

(Fig 6) Insert (2) Rod End Spacers into the holes in the tabs on the Tailgate Mount

- (2) Rod End Spacers
- (1) 12mm x 70mm Hex Bolt
- (2) 12mm Flat Washers
- (1) 12mm Nylon Lock Nut

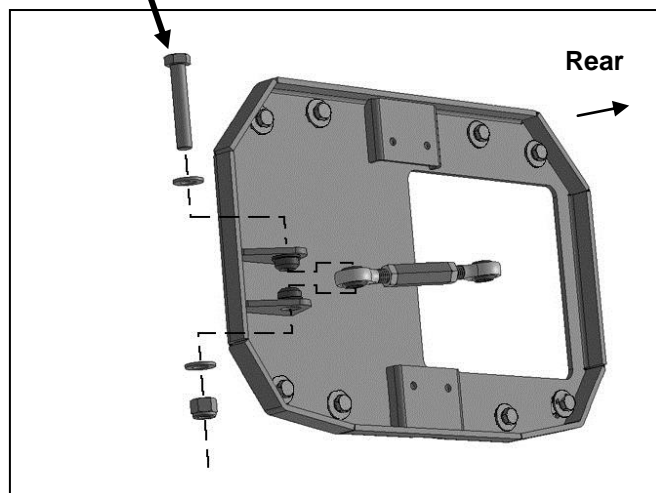

(Fig 7) Slide the end of the Adjuster Assembly between the Rod End Spacers. Attach Adjuster Assembly to tabs and Spacers

- (2) 6mm x 25mm Button Head Bolts
- (2) 6mm Lock Washers
- (2) 6mm x 12mm STD Flat Washers

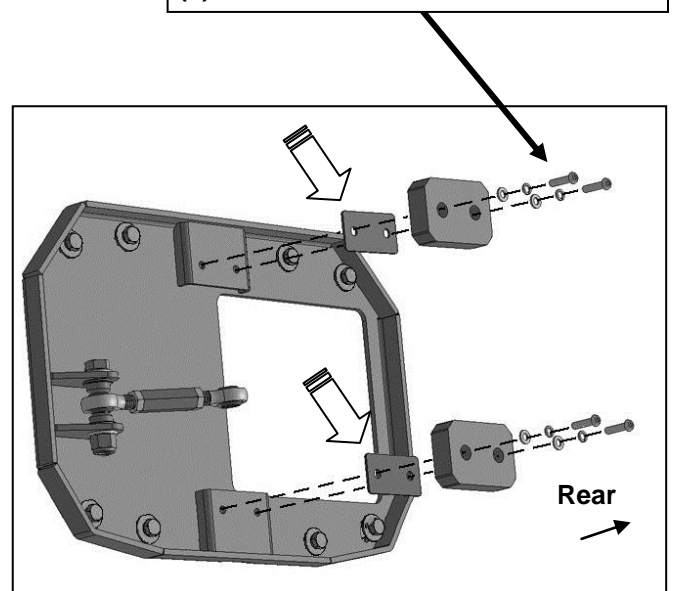

(Fig 8) Attach the Rubber Bump Stops to the Tailgate Mount. Spacers illustrated (arrows) are used for adjustment between the Swing Arm and the Bump Stops only as needed (see Fig 16)

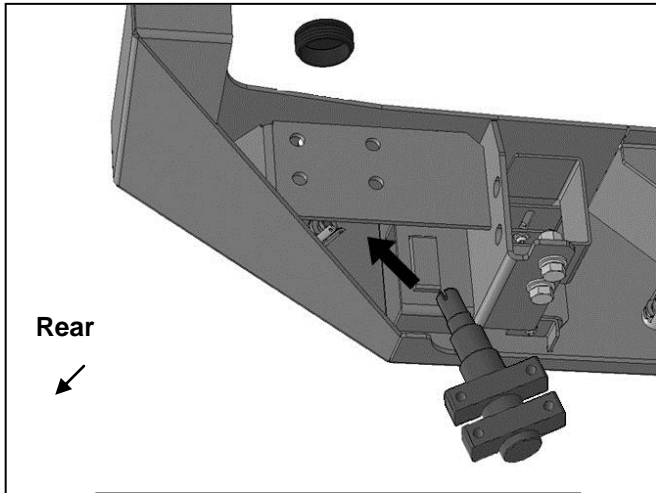

(Fig 9) Remove plug from top of Bumper. Slide Spindle up between mounting plate and back of Bumper

- (4) 12mm x 35mm Hex Bolts
- (4) 12mm Lock Washers
- (4) 12mm Flat Washers

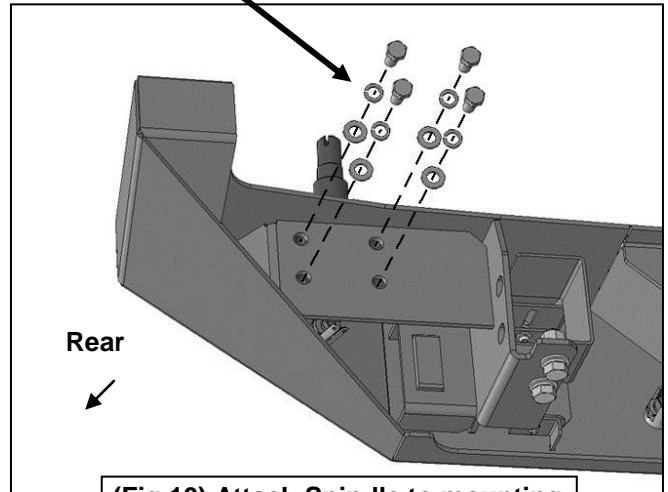

(Fig 10) Attach Spindle to mounting plate on back of Bumper

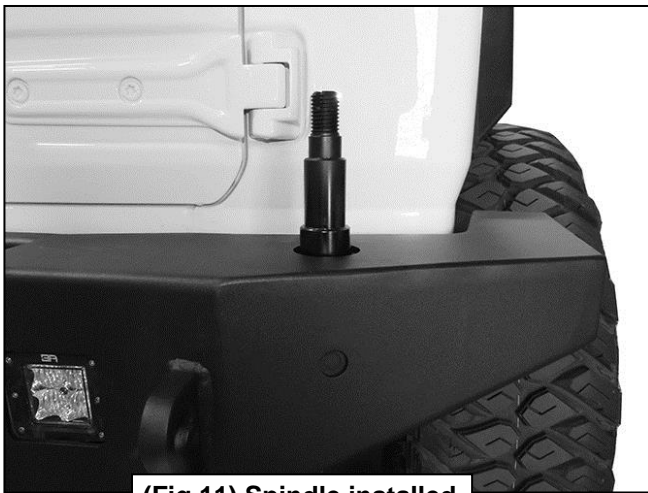

(Fig 11) Spindle installed

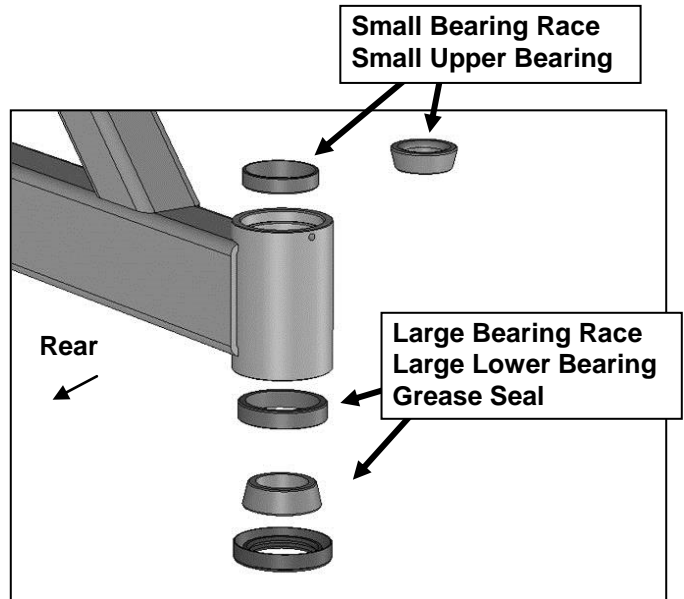

(Fig 12) Insert Upper and Lower Bearing Races into Swing Arm. Apply Grease to Lower Bearing. Insert Lower Bearing into Race. Install Grease Seal over Bearing

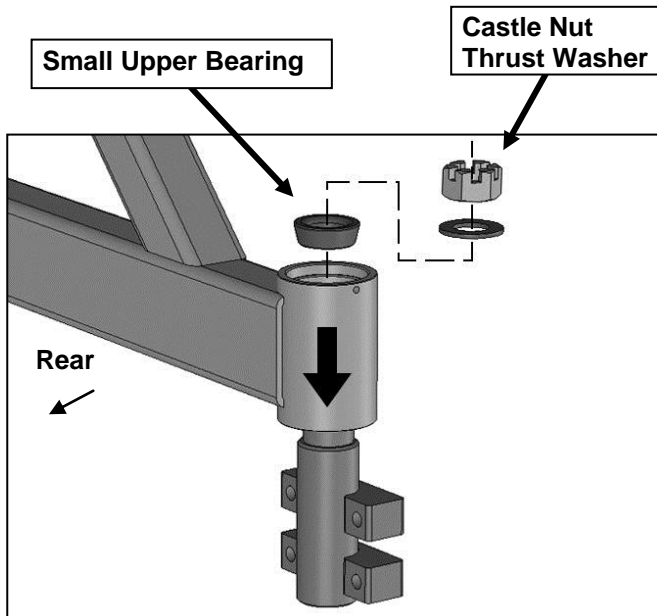

(Fig 13) Slide Swing Arm down over Spindle. Apply grease to Upper Bearing. Insert Upper Bearing into Spindle. Secure Arm to Spindle with (1) Thrust Washer and (1) Castle Nut. Tighten Castle Nut to remove play in Swing Arm

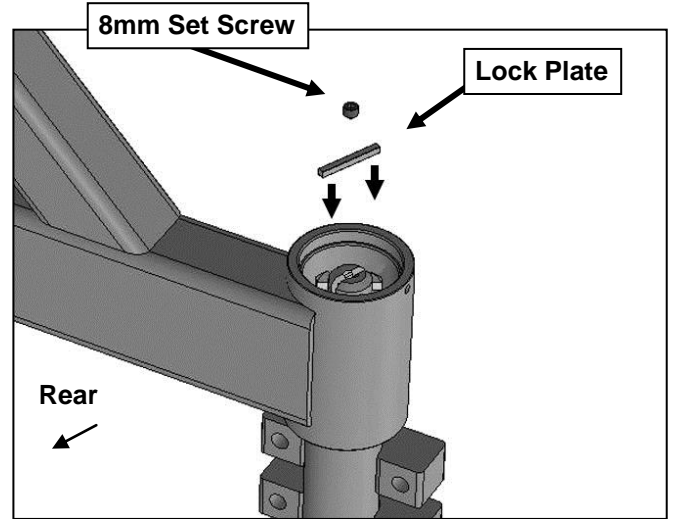

(Fig 14) Once Castle Nut is properly adjusted, slide Lock Plate down into slot in Spindle. Secure Lock Plate to Spindle with 8mm Set Screw

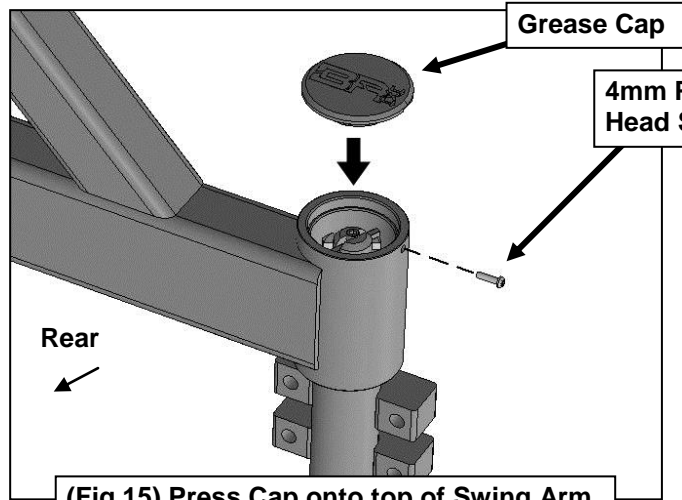

(Fig 15) Press Cap onto top of Swing Arm. Use 4mm Screw to lock Cap onto Spindle

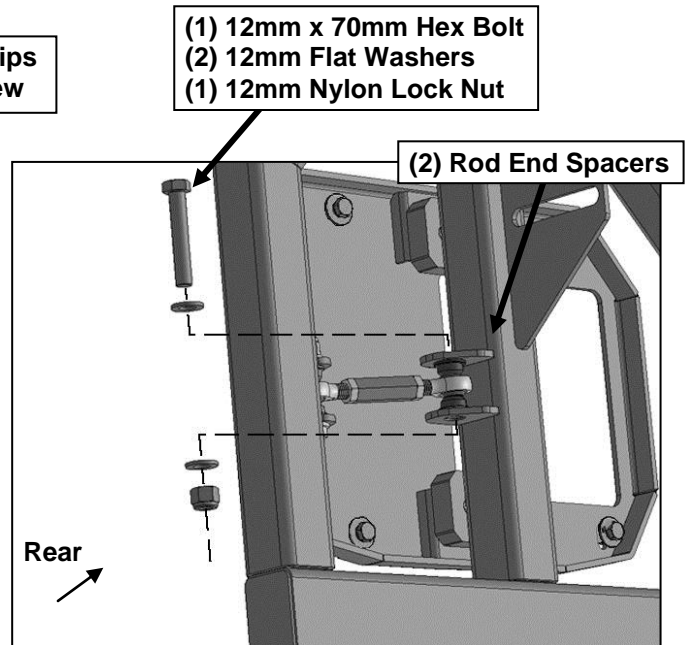

(Fig 16) Attach Adjuster Assembly to Spacers in tabs on Swing Arm

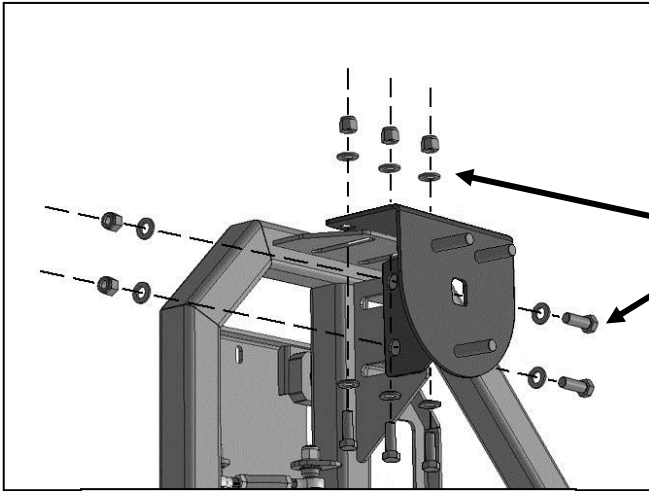

- (5) 12mm x 35mm Hex Bolts
- (10) 12mm Flat Washers
- (5) 12mm Nylon Lock Nuts

(Fig 17) Attach Tire Mount to top and left side of tabs on Swing Arm

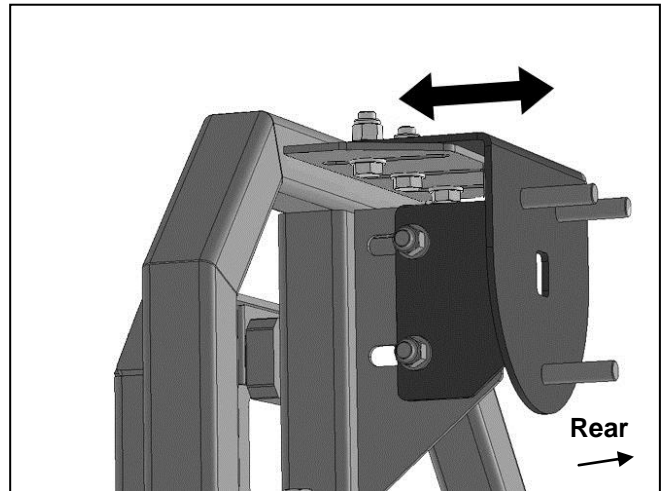

(Fig 18) Adjust Tire Mount in or out as needed to fit tire tight against the Swing Arm

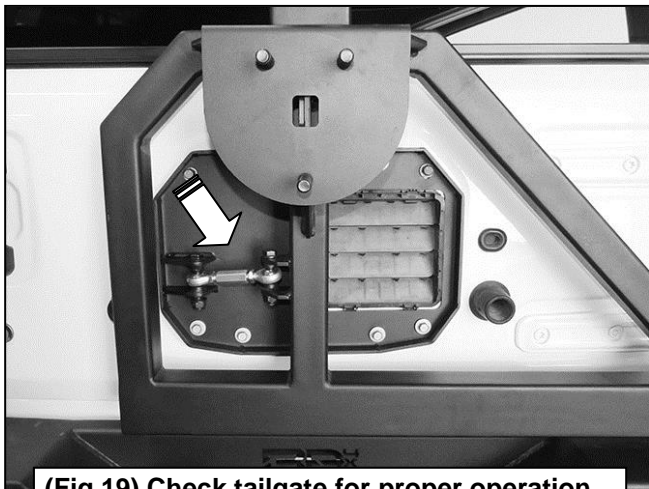

(Fig 19) Check tailgate for proper operation, adjust as needed and tighten Jam Nuts

- (3) 2mm Screws
- (3) 2mm Hex Nuts

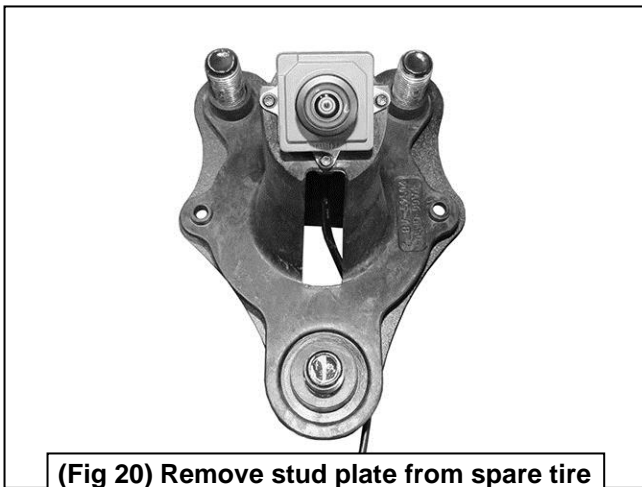

(Fig 20) Remove stud plate from spare tire mount. Remove camera and harness

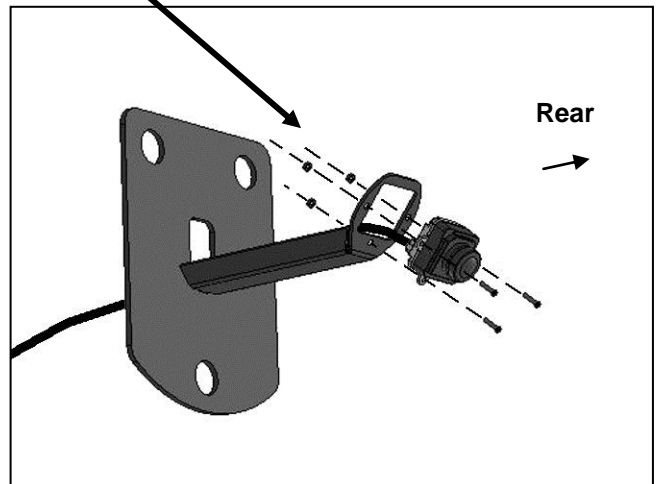

(Fig 21) Attach camera to Inner Mount

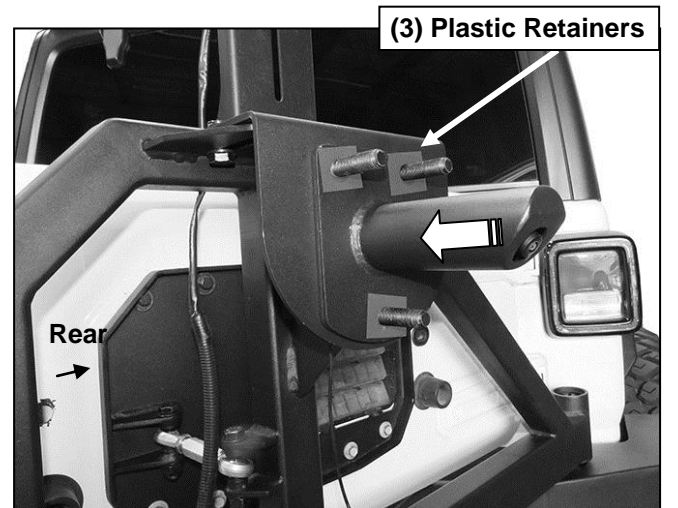
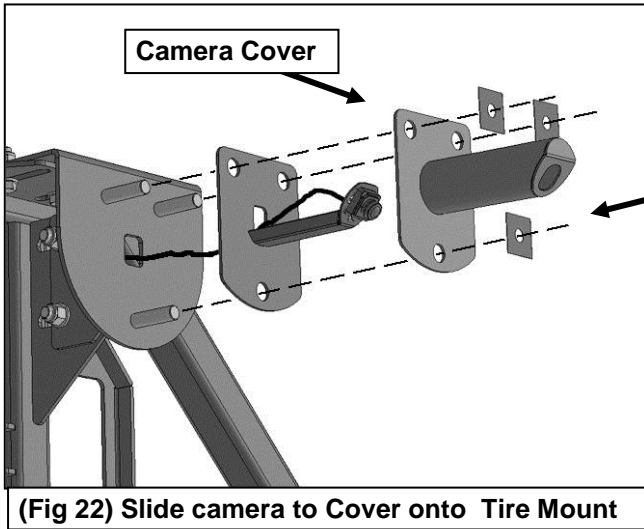

(Fig 23) Slide Inner Camera Mount over wheel bolts. Slide Outer Cover over Inner Mount. Use Plastic Retainers to hold Inner and Outer Mount in place

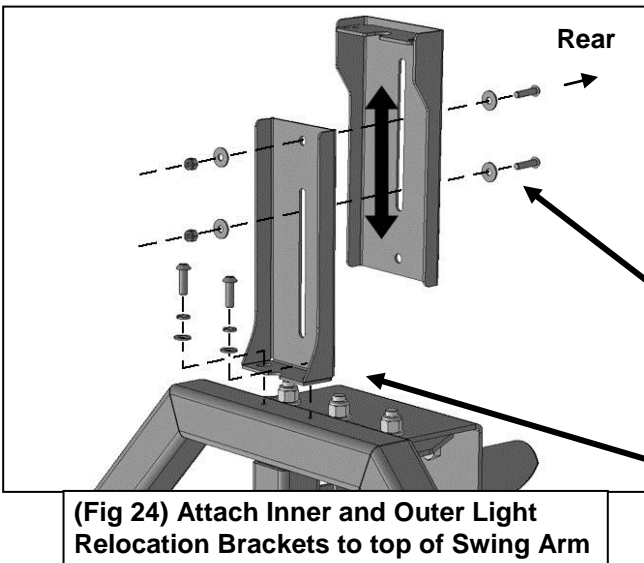

- (2) 6mm x 25mm Button Head Bolts
- (4) 6mm x 18mm Large Flat Washers
- (2) 6mm Nylon Lock Nuts
- (2) 8mm x 25mm Button Head Bolts
- (2) 8mm Lock Washers
- (2) 8mm Flat Washers

