

## 2018-2023 JEEP WRANGLER JL & GLADIATOR JT FABRICATED GRILL GUARD PART #JL-5125

### PARTS LIST:

1	Plate Style Bumper Light Bar	6	10mm Lock Washers
1	Left "L" Light Bracket	2	8-1.25mm x 25mm Hex Bolts
1	Right "L" Light Bracket	4	8mm x 24mm x 2mm Flat Washers
2	10mm Triple Nut Plates	2	8mm Lock Washers
6	10-1.5mm x 30mm Button Head Bolts	2	8-1.25mm Hex Nuts
6	10mm x 20mm x 2mm Flat Washers	1	6mm Wrench

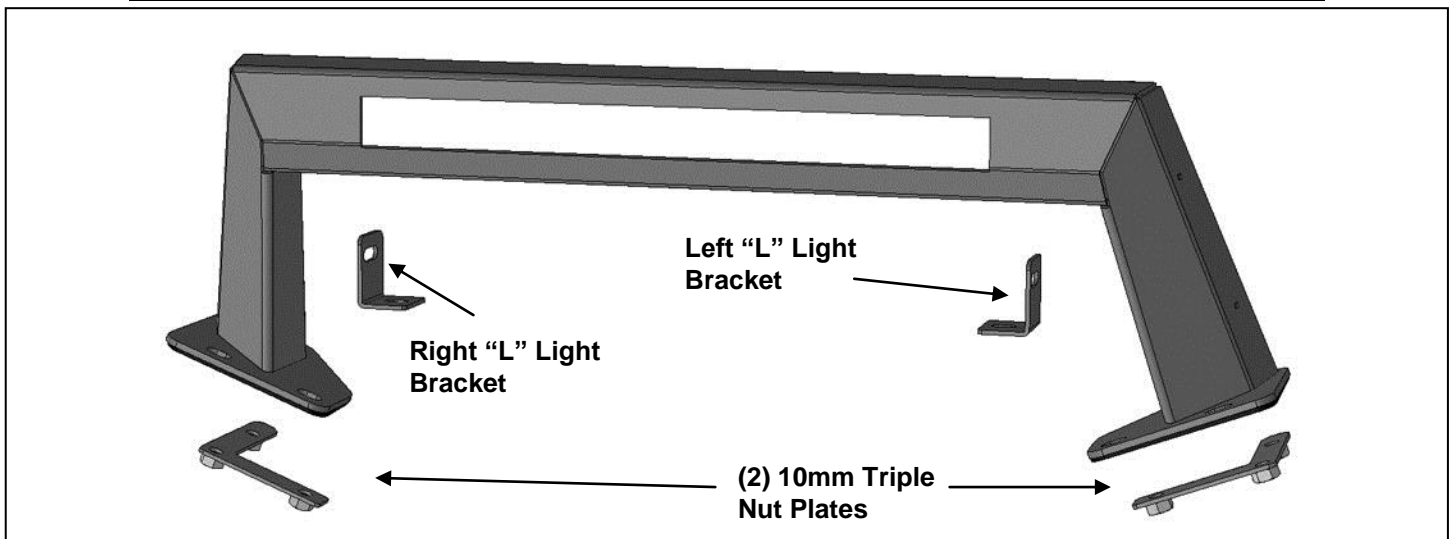

**REMOVE CONTENTS FROM BOX. VERIFY ALL PARTS ARE PRESENT. READ INSTRUCTIONS CAREFULLY BEFORE STARTING INSTALLATION. ASSISTANCE IS RECOMMENDED.**

1. Temporarily remove the Cover Plates from the back of the Front Hoop, **(Figure 1)**. Next, remove the rubber plugs from top of bumper, **(Figure 2)**. **NOTE:** Bumper is equipped with (3) plugs on each side.
2. Carefully place the Front Hoop in position on the Bumper and over the holes. Select (1) 10mm Triple Nut Plate, **(Figure 2)**. From the bottom, back of the Bumper, insert the Nut Plate into the opening in the top of the bumper mounting plate on the back of the Bumper. Hold the Nut Plate up against the inside of the Bumper, **(Figure 2)**. **IMPORTANT:** On some models, it may be necessary or easier to temporarily remove the Bumper to install the 10mm Nut Plates and Light Bar Hoop.
3. Attach the driver/left side of the Hoop to the top of the Bumper and inner Nut Plate with the included (3) 10mm x 30mm Button Head Bolts, (3) 10mm Lock Washers and (3) 10mm Flat Washers, **(Figure 2)**. Leave loose at this time.
4. Repeat **Steps 2 & 3** to attach the passenger/right side of the Hoop to the Bumper.
5. Center the Hoop on the Bumper, check the alignment and fully tighten all hardware.
6. To install inner LED bar style light, (available separately), select the Left "L" Light Bracket, **(Figure 3)**. Attach Bracket to inside of Hoop with the included (1) 8mm x 25mm Hex Bolt, (2) 8mm Flat Washers, (1) 8mm Lock Washer and (1) 8mm Hex Nut. Leave loose. **NOTE:** "L" Brackets are slightly offset to allow for fitment with different widths of lights. Repeat to attach the passenger/right "L" Light Bracket. Use the hardware included with the light to attach the light to the "L" Light Brackets. Adjust position of light and fully tighten all hardware.
7. Do periodic inspections to the installation to make sure that all hardware is secure and tight.

To protect your investment, wax this product after installing. Regular waxing is recommended to add a protective layer over the finish. Do not use any type of polish or wax that may contain abrasives that could damage the finish.

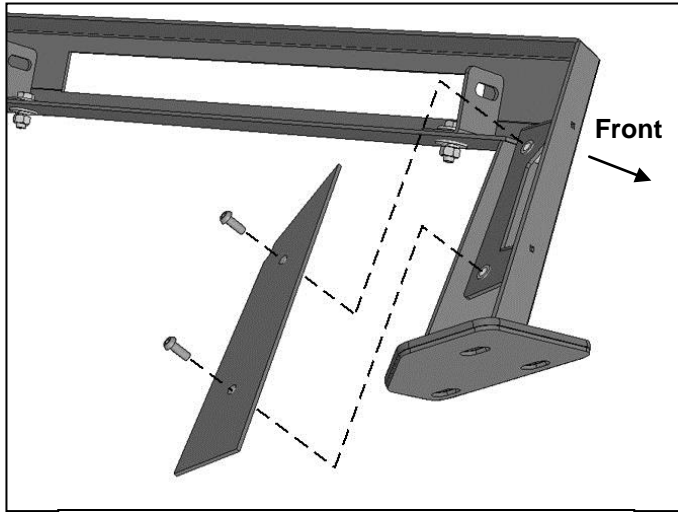

(Fig 1) Remove cover plates from Light Bar

- (3) 10mm x 30mm Button Head Bolts
- (3) 10mm Lock Washers
- (3) 10mm Flat Washers

10mm Triple Nut Plate

Remove rubber plugs

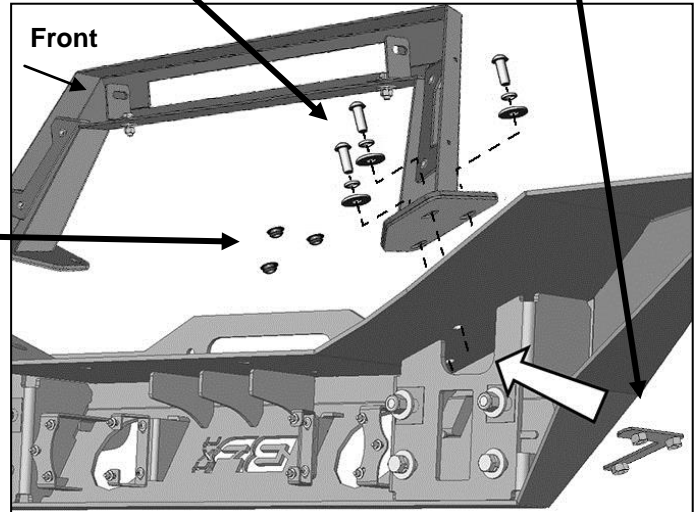

(Fig 2) Insert 10mm Triple Nut Plate into opening in top of Bumper Mounting Plate

- (2) 8mm x 25mm Hex Bolts
- (4) 8mm Flat Washers
- (2) 8mm Lock Washers
- (2) 8mm Hex Nuts

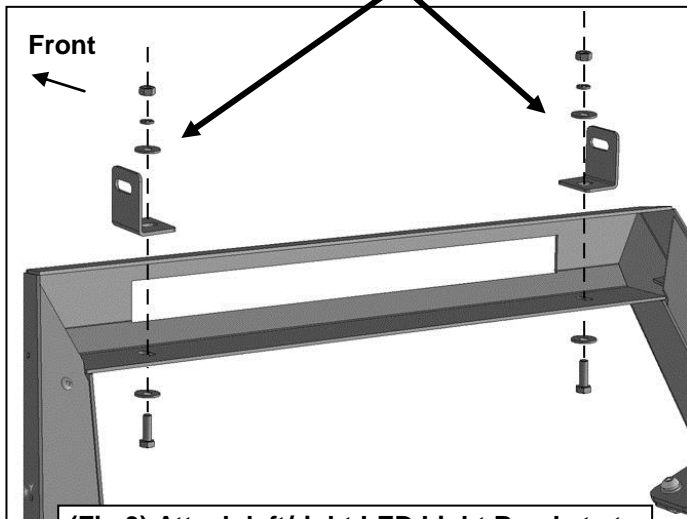

(Fig 3) Attach left/right LED Light Brackets to back of Light Bar (light available separately)