

2017-2022 FORD F-250/F-350 ECO SERIES FRONT WINCH BUMPER PART #FD-19341

PARTS LIST:

1	HD1 Front Bumper Assembly	6	10mm Lock Washers
1	Winch Tray Bracket Assembly	6	10mm Hex Nuts
2	Plastic Plugs for license plate mount	2	8-1.25mm x 25mm Hex Bolts
1	License Plate Bracket	2	8-1.25mm x 16mm Hex Bolts
1	Offset Left LED Bracket	6	8mm x 24mm x 2mm Flat Washers
1	Offset Right LED Bracket	4	8mm Lock Washers
4	12-1.75mm x 170mm Hex Bolts	2	8mm Hex Nuts
8	12-1.75mm x 50mm Hex Bolts	2	6mm x 20mm Button Head Screw
24	12mm x 32mm x 3mm Flat Washers	4	6mm x 18mm x 1.6mm Flat Washers
12	12mm Lock Washers	2	6mm Nylon Lock Nut
12	12mm Hex Nuts	1	4mm Wrench(6mm)
6	10mm x 34mm x 3mm Flat Washers		

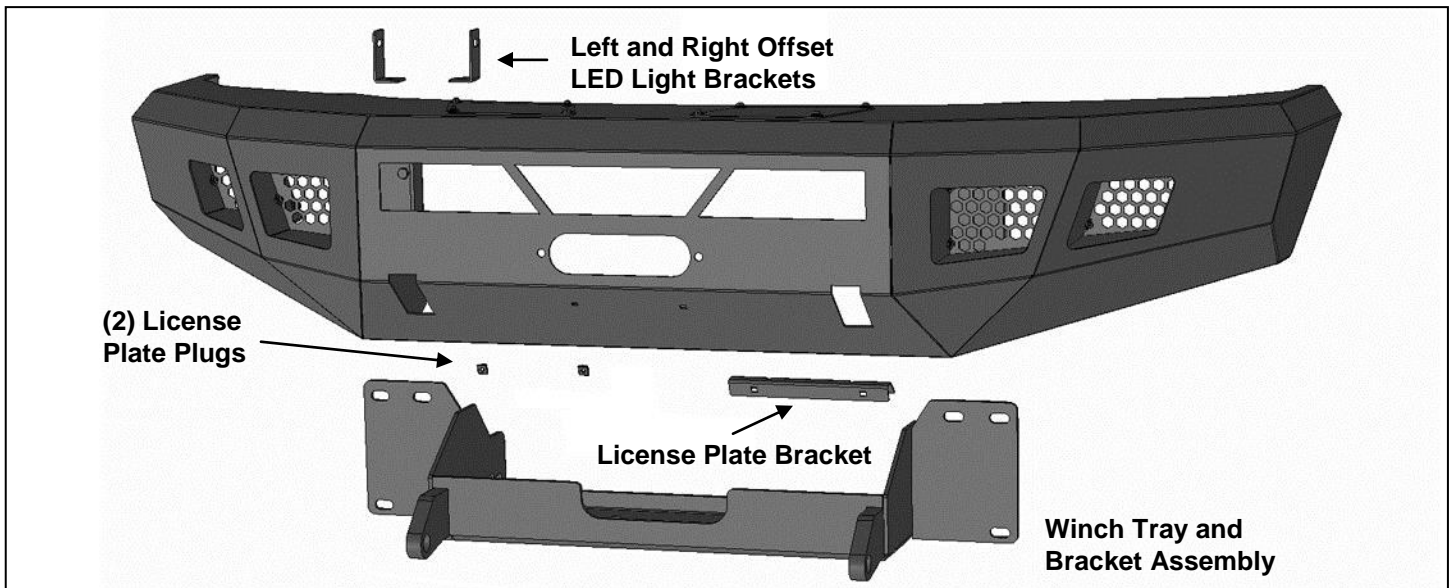

PROCEDURE:

REMOVE CONTENTS FROM BOX. VERIFY ALL PARTS ARE PRESENT. READ INSTRUCTIONS CAREFULLY BEFORE STARTING INSTALLATION. BUMPER IS HEAVY, ASSISTANCE IS HIGHLY RECOMMENDED TO AVOID POSSIBLE INJURY OR DAMAGE TO THE VEHICLE.

1. Remove the license plate and bracket. On models with factory fog lights, unplug both lights. Release the wiring harness from the clips attached to the back of the bumper, (**Figures 1 & 2**). Move harness away from bumper.
2. Remove the driver/left bumper support attached to the bumper frame bracket and outer end of the bumper, (**Figure 2**). Remove the plastic covers from the tow hooks to uncover the bumper bolts, (**Figures 3 & 4**). Repeat this Step to remove the passenger/right side bumper support and cover.
3. Place blocks or jack stands under the front bumper to support it during mounting bolt removal. Once the bumper has been safely supported, remove the factory bumper bolts, (**Figure 4**).



INSTALLATION INSTRUCTIONS

WARNING! Assistance is required to hold the bumper in place during bolt removal to prevent the bumper from falling. Carefully slide the bumper off over the tow hooks, **(Figure 5)**.

4. Remove the driver side tow hook assembly from the end of the frame, **(Figure 6)**. Next, remove the lower frame extension and double bolt plate from the end of the frame, **(Figures 5 & 6)**. Repeat this Step to remove the passenger side tow hook and lower frame extension.
5. Next, select the Winch Tray Bracket Assembly. Slide the assembly over the ends of the frame. Line up the (2) slots in each side of the assembly with the holes in the side of the frame. Attach the assembly to the frame with the included (2) 12mm x 170mm Hex Bolts, (4) 12mm Flat Washers, (2) 12mm Lock Washers and (2) 12mm Hex Nuts, **(Figures 7 & 8)**. Leave hardware loose.
6. Attach the top of the Winch Tray assembly to the frame with (4) 12mm x 50mm Hex Bolts, (8) 12mm Flat Washers, (4) 12mm Lock Washers and (4) 12mm Hex Nuts, **(Figures 7 & 8)**. Leave hardware loose. Repeat to attach the Winch Tray assembly to the passenger side of the frame.
7. If installing winch, (not included), attach the winch to the Winch Tray at this time. Winch must be installed before Bumper is placed in position against Brackets. **NOTE:** Attach winch cable guide, (not included), to Bumper assembly. Follow manufacturer's instructions to properly attach the winch to the vehicle's electrical system.
8. **Optional Center LED light installation** (sold separately). **NOTE:** Light must be installed before Bumper Assembly is attached to the Winch Tray. **IMPORTANT:** Clearance between the bar style LED light and the winch and/or winch tray must be determined before installing Bumper assembly.
 - a. Select the L/R "L" Brackets, **(Figures 9 & 10)**. **NOTE:** "L" Brackets are offset for universal fitment for most LED bar style lights. Attach the LED light assembly to the "L" Brackets with the included (2) 8mm x 16mm Hex Bolts, (2) 8mm Lock Washers and (2) 8mm Flat Washers, **(Figure 10)**. Do not fully tighten hardware at this time. **NOTE:** "L" Brackets may require modification for hardware larger than 8mm or use brackets supplied with light if possible.
 - b. Attach the light and brackets to the top of the (2) tabs on the back of the Bumper with the included 8mm x 25mm Hex Bolts, (4) 8mm Flat Washers, (2) 8mm Lock Washers and (2) 8mm Hex Nuts, **(Figure 10)**. Adjust light position and tighten hardware.
 - c. Follow light manufacturer's instructions to wire the light to the vehicle's electrical system once Bumper has been fully installed.
9. **LED light installation at ends of bumper** (sold separately).
 - a. Insert light into opening and up to mounting slots. Check for clearance between front and back of light. If necessary, remove the screens from the back of the openings, **(Figure 11)**.
 - b. Follow the light manufacturer's instructions to attach each light to slot in the top of the light opening, **(Figure 11)**. **NOTE:** On two light systems, attach the flood light to the outer slot and the spot light to the inner slot.
 - c. Repeat the above steps for passenger side light installation.
 - d. Follow light manufacturer's instructions to properly wire the light to the vehicle electrical system.
10. If front license plate is required, attach the License Plate Bracket to the holes in the bumper with the included (2) 6mm x 20mm Button Head Screws, (4) 6mm Flat Washers and (2) 6mm Nylon Lock Nuts, **(Figure 12)**. Insert (2) Plastic Plugs into the square holes in the Bracket. Reuse the factory screws to attach the license plate to the plastic plugs, **(Figure 12)**.
11. With assistance, carefully position the Bumper Assembly up to the ends of the Winch Tray. Temporarily support the weight of the Bumper. **WARNING:** To avoid possible injury or damage to the vehicle, do not proceed until the bumper is fully and safely supported. Models with winch and/or LED light, check for clearance before fully installing Bumper assembly.
12. Line up the (3) 10mm Studs in the driver side of the Bumper with the (3) holes in the Winch Tray. Attach the Bumper to the Winch Tray with the included (3) 10mm Flat Washers, (3) 10mm Lock Washers and (3) 10mm Hex Nuts, **(Figures 13 & 14)**. Do not fully tighten hardware at this time. Repeat to attach the passenger side of the Bumper to the Winch Tray.
13. Level and adjust the bumper and fully tighten all hardware.
14. Remove covers from top of Bumper for additional access if desired.

15. Do periodic inspections to the installation to make sure that all hardware is secure and tight.

To protect your investment, wax this product after installing. Regular waxing is recommended to add a protective layer over the finish. Do not use any type of polish or wax that may contain abrasives that could damage the finish. Mild soap may be used to clean the HD1 Front Bumper assembly.

Driver Side Installation Pictured

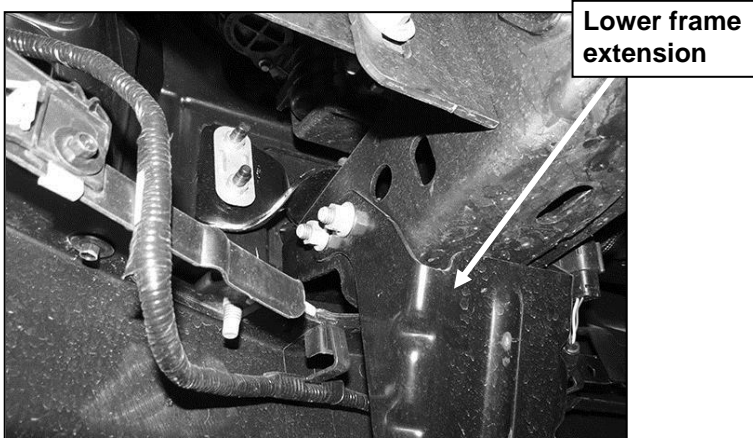

(Fig 1) Driver side lower frame extension and fog light wire harness pictured from behind bumper



(Fig 2) Remove outer bumper support

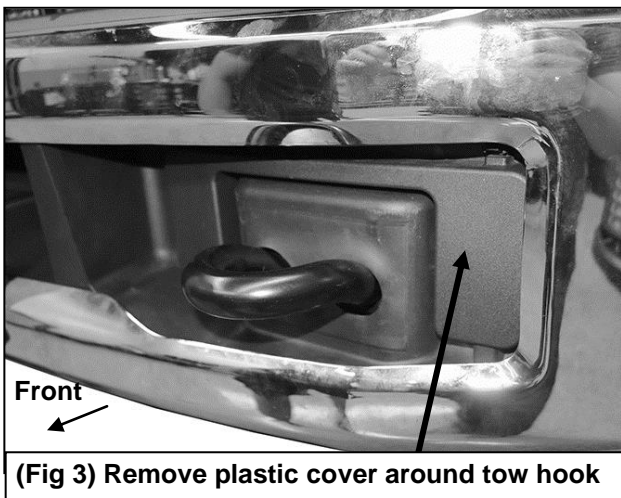

(Fig 3) Remove plastic cover around tow hook

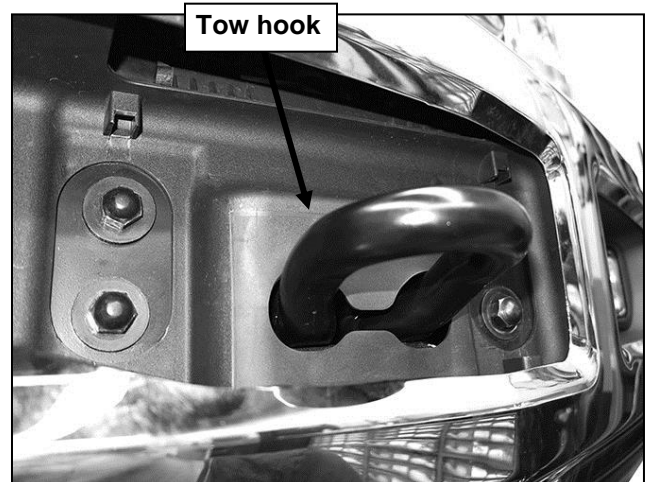

(Fig 4) Remove bumper bolts (driver side pictured)

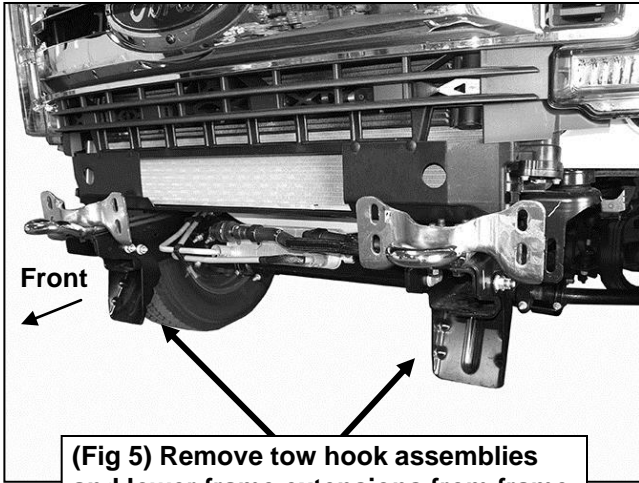

WARNING! Do not remove bumper bolts unless the bumper is properly supported on blocks or stands or the bumper may fall.

- | | |
|---------------------------|----------------------------|
| (4) 12mm x 50mm Hex Bolts | (2) 12mm x 170mm Hex Bolts |
| (8) 12mm Flat Washers | (4) 12mm Flat Washers |
| (4) 12mm Lock Washers | (2) 12mm Lock Washers |
| (4) 12mm Hex Nuts | (2) 12mm Hex Nuts |

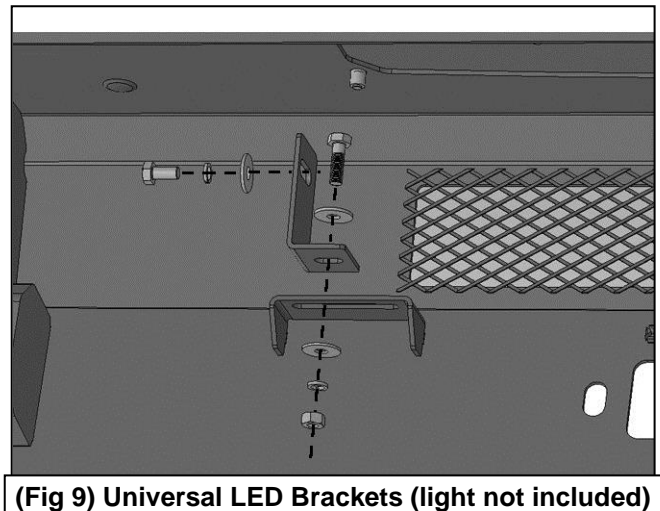
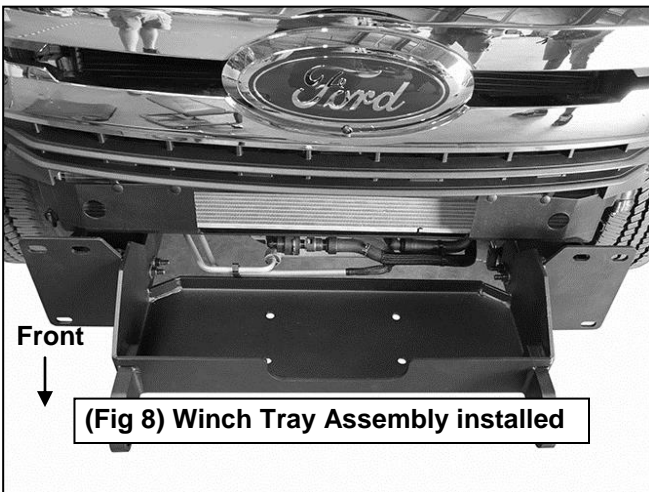
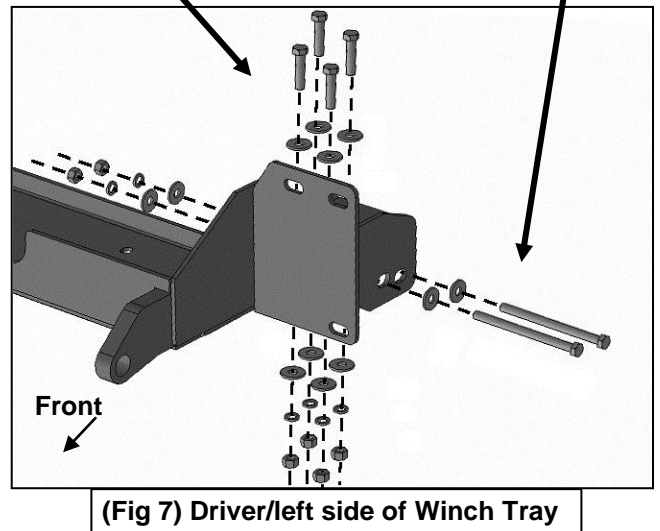
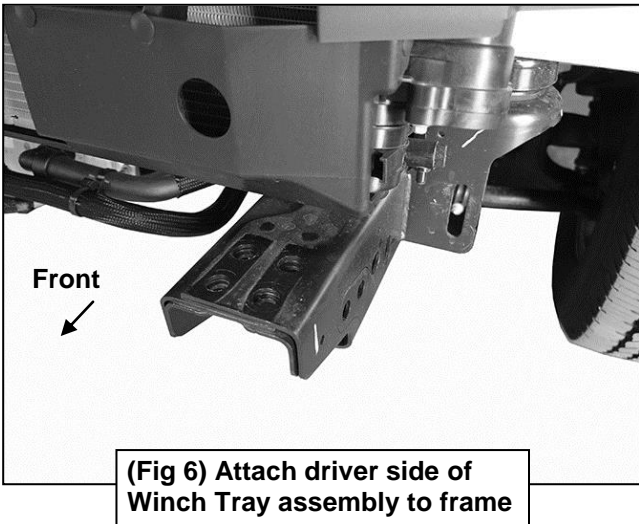

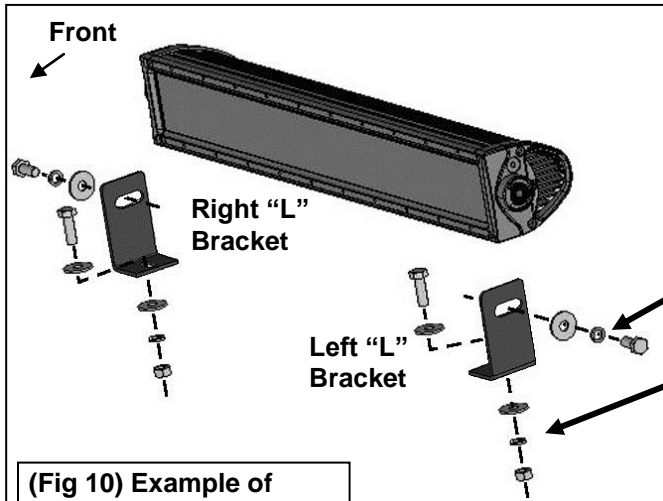

(Fig 10) Example of center light installation

- (2) 8mm x 16mm Hex Bolts
- (2) 8mm Lock Washers
- (2) 8mm Flat Washers

- (2) 8mm x 25mm Hex Bolts
- (4) 8mm Flat Washers
- (2) 8mm Lock Washers
- (2) 8mm Hex Nuts

WARNING! Do not crawl under bumper unless the bumper is properly supported on blocks or stands or the bumper may fall.

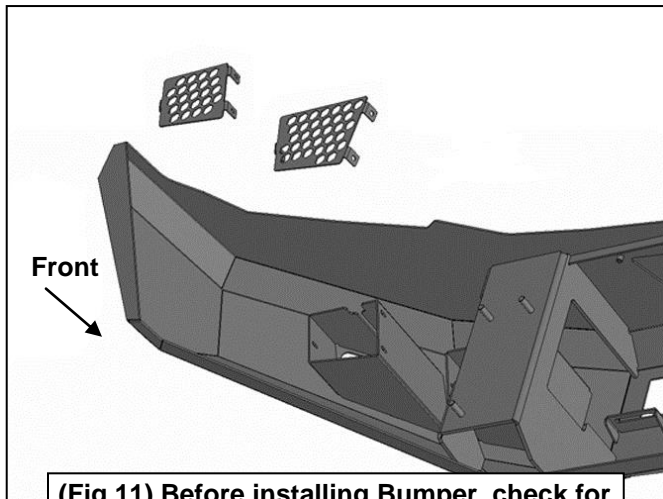

(Fig 11) Before installing Bumper, check for clearance around lights (not included). Remove screens for additional access or to clear lights as needed

- (2) 6mm x 20mm Button Head Screws
- (4) 6mm Flat Washers
- (2) 6mm Nylon Lock Nuts

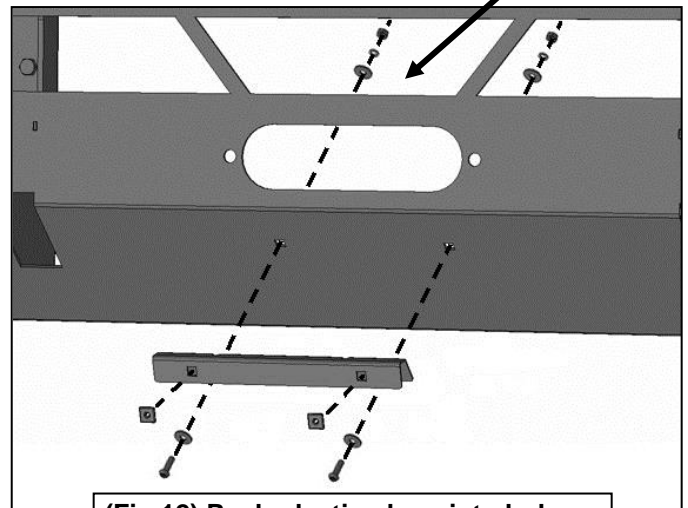

(Fig 12) Push plastic plugs into holes in Bumper for license plate if required

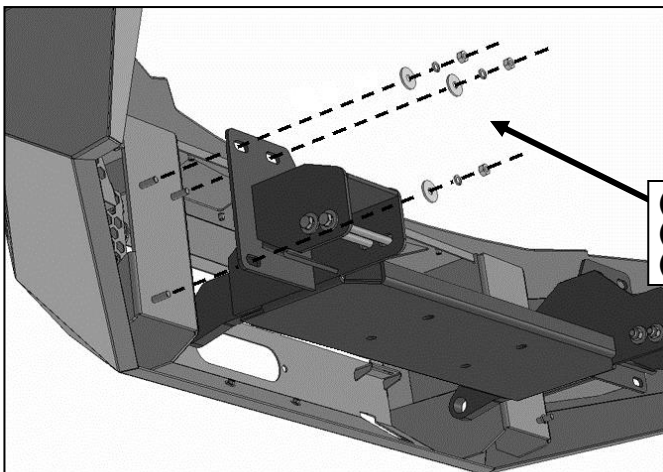

(Fig 13) Attach Bumper to Winch Tray Brackets

- (3) 10mm Flat Washers
- (3) 10mm Lock Washers
- (3) 10mm Hex Nuts

- (3) 10mm Flat Washers
- (3) 10mm Lock Washers
- (3) 10mm Hex Nuts

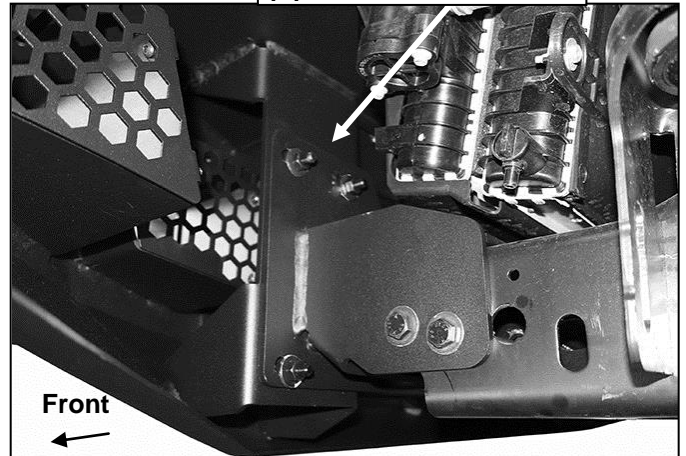

(Fig 14) Driver/left side of Bumper and Bracket