

2019-2023 JEEP GLADIATOR JT BED SIDE MOLLE SYSTEM (SINGLE UNIT) PART #JT-7125

PARTS LIST:

1	Side Panel	4	8mm x 24mm x 2mm Flat Washers
1	Logo Plate	4	8mm Lock Washers
3	Upper Mounting Brackets	2	6-1.00 x 30mm Socket Head Bolt
1	8mm Nut Plate	3	6-1.00 x 25mm Button Head Bolts
3	6mm ID Rubber Bumpers	2	6-1.00 x 15mm Button Head Bolts
1	8mm ID Nylon Spacer	3	6mm x 18mm x 1.6mm STD Flat Washers
2	14mm x 28mm x 2.5mm Flat Washers	4	6mm x 12mm x 1.6mm Small Flat Washers
2	12mm Large Wing Nuts	2	6mm x 10mm x 1mm Plastic Flat Washers
2	12-1.75mm x 45mm Carriage Bolts	3	6mm Lock Washers
3	10mm x 27mm x 3mm Flat Washer	2	6-1.00mm Nylon Lock Nut
3	10mm x 24mm x 2.2mm Flat Washer	2	6-1.00mm Flange Nuts
1	8-1.25mm x 40mm Button Head Bolt	1	5mm Wrench
3	8-1.25mm x 20mm Button Head Bolts	1	4mm Wrench

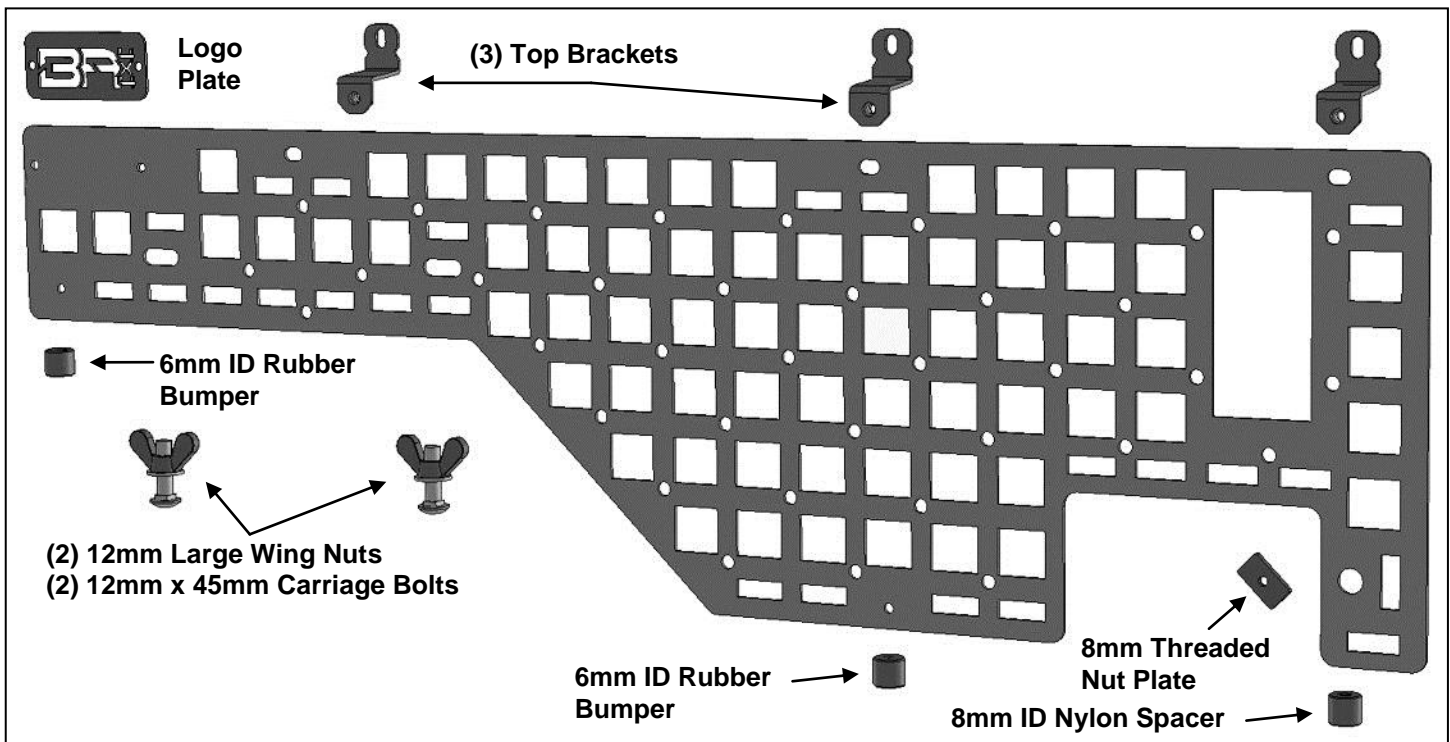

PROCEDURE:

REMOVE CONTENTS FROM BOX. VERIFY ALL PARTS ARE PRESENT. READ INSTRUCTIONS CAREFULLY BEFORE STARTING INSTALLATION. ASSISTANCE IS RECOMMENDED.

IMPORTANT: LET EXHAUST COOL BEFORE STARTING INSTALLATION.

1. Determine which side to install the Side Panel. Locate the (3) threaded mounting holes below the top along the side of the bed, (**Figure 1**). **NOTE:** Use a 6mm x 1.0mm tap, (not included), to clean the



INSTALLATION INSTRUCTIONS

threaded holes if covered by spray-in bed liner or undercoating/paint. Models with utility track, temporarily remove the track from the top of the bed.

2. Select (1) Top Bracket. Attach the Top Bracket to the mounting hole closest to the tailgate with the included (1) 6mm x 25mm Button Head Bolt, (1) 6mm Lock Washer and (1) 6mm x 18mm Large Flat Washer, **(Figure 2)**. Do not fully tighten hardware at this time. Repeat this **Step** to install the remaining (2) Top Brackets, **(Figure 3)**. **NOTE:** Models with utility track, reinstall the track over the Top Brackets.
3. Unwrap the Panel. Attach the Logo Plate to the correct side of the Panel with the included (2) 6mm x 15mm Button Head Bolts, (2) 6mm x 10mm Plastic Washers and (2) 6mm Flange Nuts, **(Figure 4)**.
4. Attach (1) Rubber Bumper to the bottom front mounting hole in the Panel with the included (1) 6mm x 30mm Socket Head Bolt, (2) 6mm x 12mm Small Flat Washers, (1) 10mm x 24mm STD Flat Washer, (1) 10mm x 27mm Thick Flat Washer and (1) 6mm Nylon Lock Nut, **(Figure 5)**. Insert the 10mm Flat Washers between the Rubber Bumper and the back of the Panel to act as a spacer to push the Bumper up against the front of the bed, **(Figures 5 & 6)**. Adjustment may be required, **(see Step 9)**. Repeat this Step to install the remaining Rubber Bumper in the center location at the bottom of the Panel.
5. Determine layout for desired accessory mounts, (accessories not included). **NOTE:** Mounts or brackets typically must be installed before attaching Panel to vehicle.

Beam style recovery jack, (jack not included):

- a. Insert (1) 12mm x 45mm Carriage Bolt through the back of the panel and out through the oval hole, **(Figure 7)**. Slide (1) 14mm Flat Washer over Carriage Bolt. Thread (1) 12mm Large Wing Nut onto the Carriage Bolt. Repeat to install remaining Carriage Bolt, Flat Washer and Wing Nut.
- b. Use the Flat Washers and Wing Nuts to attach jack to Carriage Bolts, **(Figures 7 & 8)**.
6. Slide the Panel into position. Attach the top of the panel to the Top Brackets with (3) 8mm x 20mm Button Head Bolts, (3) 8mm Lock Washers and (3) 8mm Flat Washers, **(Figure 9 & 10)**. Do not fully tighten hardware at this time.
7. Select the 8mm Rectangular Nut Plate. From immediately behind the rear wheel opening, insert the Nut Plate up into the gap between the outer body panel and inner bed side, **(Figure 11)**. Line up the threaded hole with the hole behind the bed cargo loop, **(Figure 12)**. **NOTE:** Assistance may be required or use tape to hold the Nut Plate in place.
8. Insert (1) 8mm x 40mm Button Head Bolt with (1) 8mm Lock Washer and (1) 8mm Flat Washer through the bottom rear mounting hole, **(Figure 13)**. Slide (1) 10mm x 24mm STD Flat Washer, (1) 10mm x 27mm Thick Flat Washer and the 8mm Plastic Spacer onto the Bolt, **(Figure 14)**. Thread the Bolt into the Nut Plate.
9. Align and adjust the Side Panel and fully tighten all hardware, **(Figure 15)**. If necessary, remove or move the 10mm Spacer Washers on the Rubber Bumpers and 8mm Plastic Spacer to make the Panel flat and level against the side of the bed, **(Figures 6, 7 & 13)**.
10. Do periodic inspections to the installation to make sure that all hardware is secure and tight.

To protect your investment, Do not use any type of polish or wax that may contain abrasives that could damage the finish. Mild soap may be used to clean the Panel.

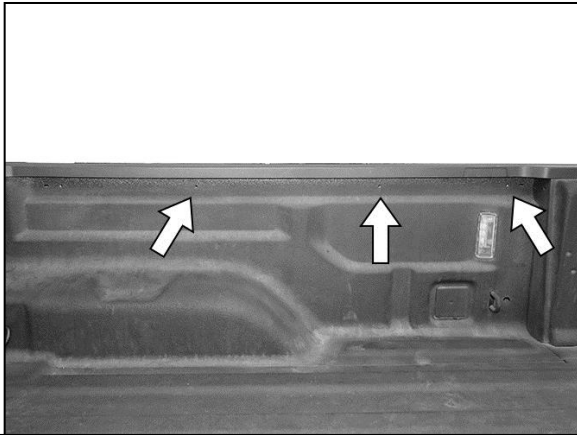

(Fig 1) Locate the (3) threaded holes along the top of the bed (passenger/right side pictured). Use a 6mm x 1.0mm tap (not included) to clean paint or bed liner material from threads

- 6mm x 25mm Button Head Bolt
- 6mm Lock Washer
- 6mm Flat Washer

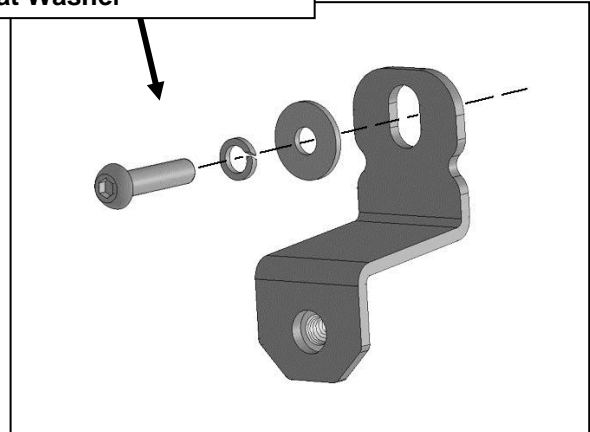

(Fig 2) Attach Top Bracket to threaded holes in bed. Models with factory utility track, insert and install Top Brackets between track and bed

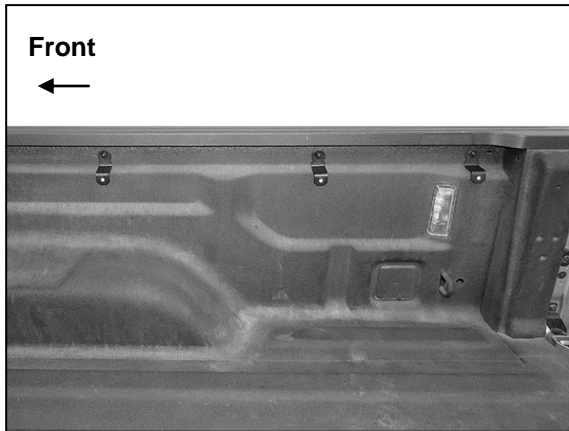

(Fig 3) Top Brackets attached to threaded holes in bed. Models with factory utility track, insert and install Top Brackets between track and bed

- (2) 6mm x 15mm Button Head Bolts
- (2) 6mm Plastic Flat Washers
- (2) 6mm Flange Nuts

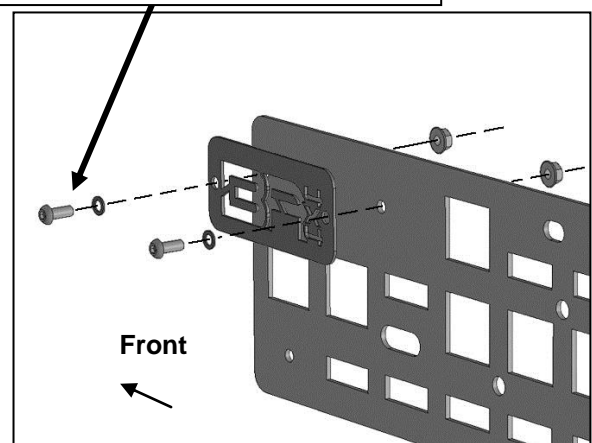

(Fig 4) Attach Logo Plate to front of Panel

Use either or both
 10mm x 27mm Thick Flat Washer
 10mm x 24mm Thin Flat Washer

6mm x 30mm Socket Head Bolt
 (2) 6mm x 12mm Small Flat Washers
 6mm Nylon Lock Nut

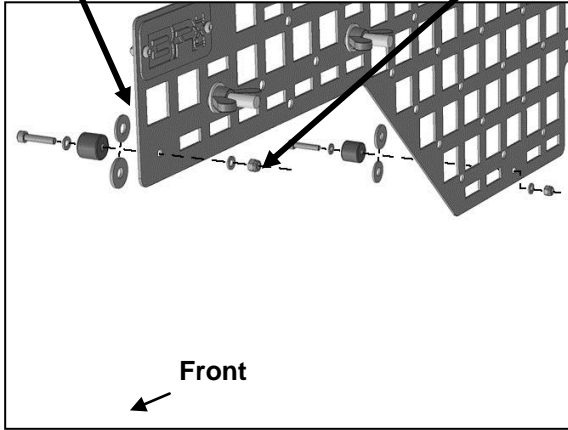

(Fig 5) Attach the Rubber Bumpers to rear facing side of the Panel, between the Panel and the side of the bed. Use the 10mm Flat Washers to adjust the Bumper to push against the side of the bed.

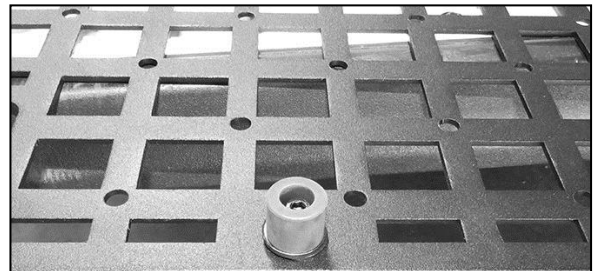

(Fig 6) Rubber Bumper attached to back of Panel with added Spacer Washers

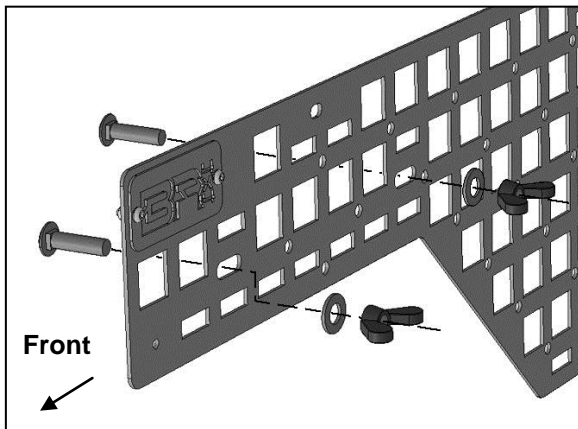

(2) 12mm x 45mm Carriage Bolts
 (2) 14mm Flat Washers
 (2) 12mm Large Wing Nuts

(Fig 7) Insert Carriage Bolts through back of Panel to attach beam style recovery jack



(Fig 8) Example of beam style recovery jack attachment to Carriage Bolts in Panel (arrows)

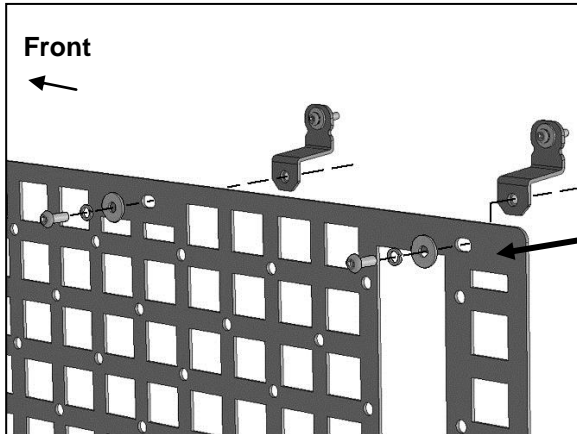

(Fig 9) Attach top of Panel to Top Brackets. Rear and center Top Brackets illustrated

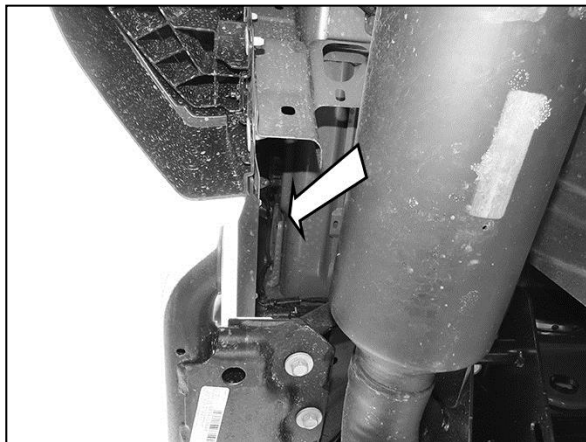

(Fig 11) Hold Nut Plate up in place behind inner bed side body panel (arrow)

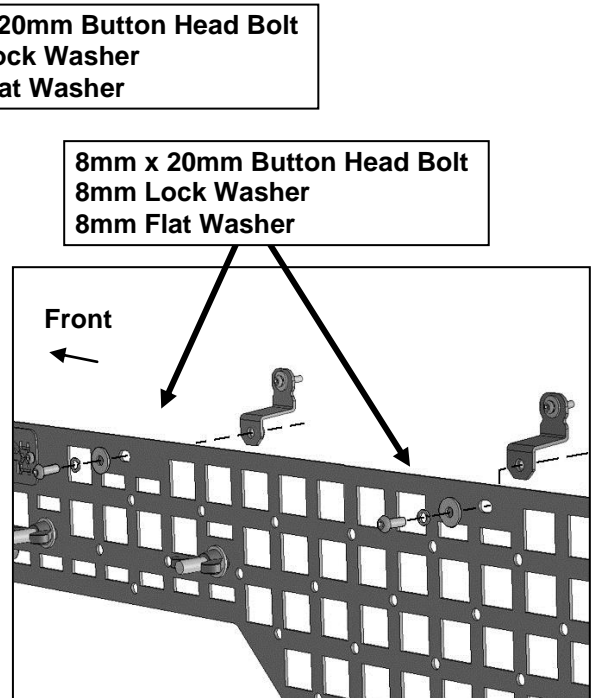

(Fig 10) Attach top of Panel to Top Brackets. Center and front Top Brackets illustrated

Use either or both
10mm x 27mm Thick Flat Washer
10mm x 24mm Thin Flat Washer

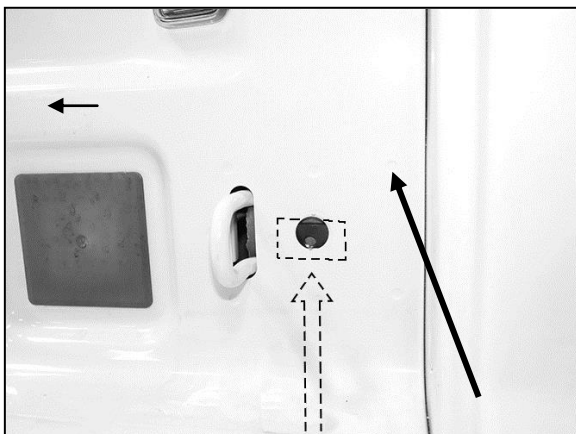

(Fig 12) Insert 8mm Nut Plate up between outer body panel and inner bed sheetmetal. Line up threaded hole with hole in bed

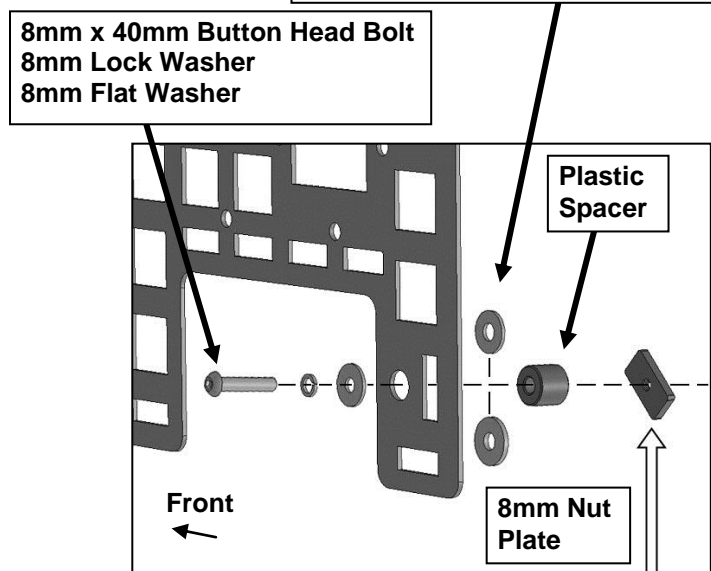

(Fig 13) Attach Lower "L" Brackets to Panel

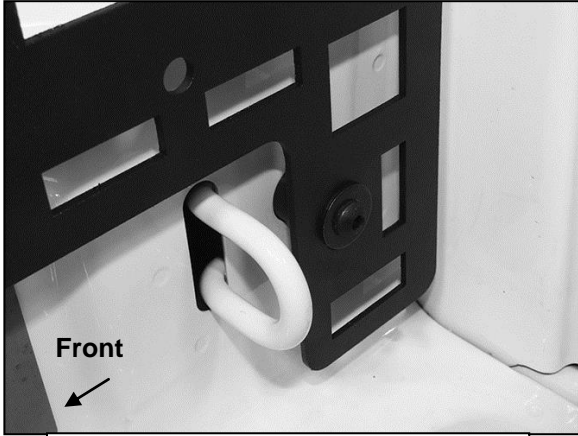

(Fig 14) Side Panel attached to 8mm Nut Plate behind rear bed tie down

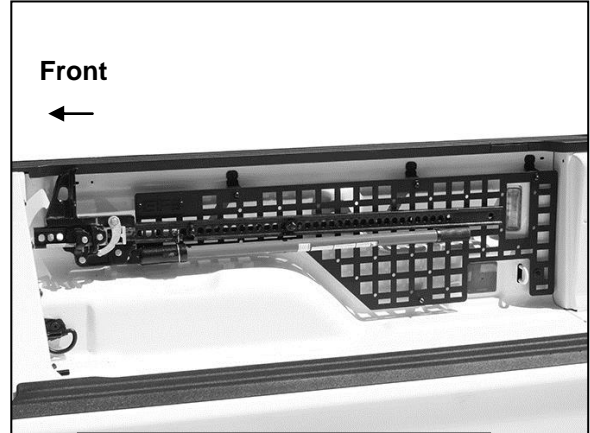

(Fig 15) Complete installation, (jack pictured not included)