



# INSTALLATION INSTRUCTIONS



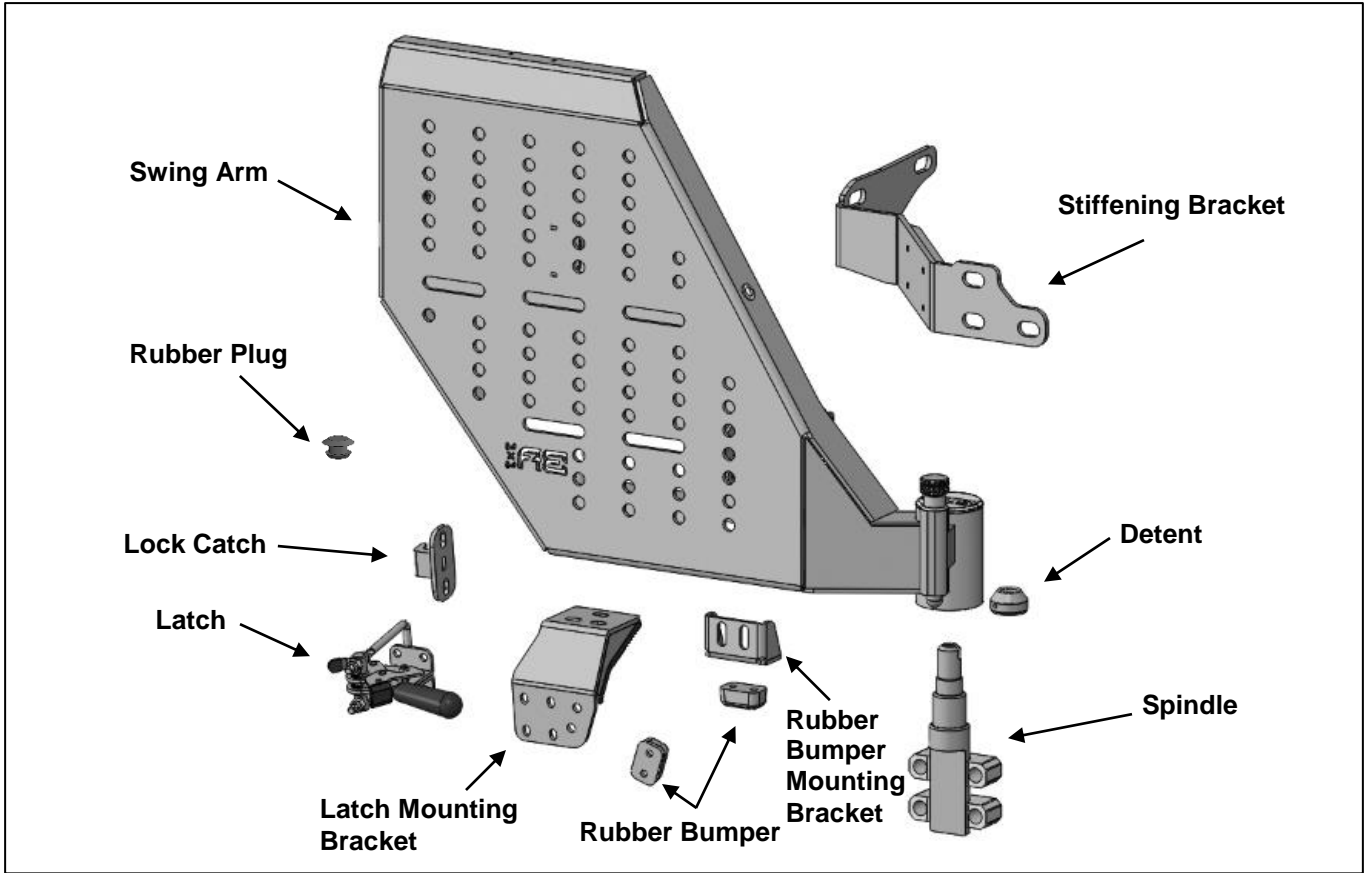

## 2016-2023 TOYOTA TACOMA PRO SERIES PASSENGER SIDE SWINGOUT PART #TC-2966PS

### PARTS LIST:

Qty	Item Description	Qty	Item Description
1	Passenger/Right Swing Arm	1	0.16m Rubber Trim
1	Passenger/Right Stiffening Bracket	1	Φ10 Plug
1	Spindle	1	M24 Castle Nut
1	Latch Mounting Bracket	4	12-1.75mm x 65mm Hex Bolt
1	Lock Catch	4	12mm x 32mm x 3mm Flat Washers
1	Latch	4	12mm Lock Washers
1	Rubber Bumper Mounting Bracket	6	M8_20 Button Head Bolt
2	Rubber Bumper	3	M8_25 Button Head Bolt
1	1mm Rubber Bumper Shim	1	M8_8 Screw
1	2mm Rubber Bumper Shim	8	8mm Nylon Lock Nut
1	Spindle Cap	3	M8_25 Hex Bolt
1	Detent	4	8mm x 22mm x 2mm Flat Washer
1	1mm Pin Spacer	1	8mm x 24mm x 2mm Flat Washer
1	2mm Pin Spacer	15	8mm x 16mm x 1.6mm Flat Washer
1	Bearing Retainer	4	M6_20 Button Head Bolt
1	Pin	4	6mm Nylon Lock Nut
1	Small NSK Bearing	8	6mm x 12mm x 1.6mm Flat Washer
1	Large NSK Bearing	1	M4_15 Phillips Screw
1	Lower Bearing Seal	1	S=4 Wrench
1	0.1m Rubber Trim	1	S=5 Wrench

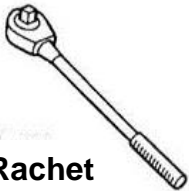

## TOOLS REQUIRED

 <p>Ratchet</p>	 <p>Sockets</p>	 <p>Extensions</p>	 <p>Wrench</p>
--	--	--	---

## PRODUCT CARE AND MAINTENANCE

- Textured coat finished should be cleaned ONLY with a mild soap on a damp sponge.
- BA recommends wiping down the product with a light coat of lubricate (i.e. WD40) periodically to maintain its luster.
- DO NOT apply polish or wax that requires buffing for removal as this may damage the finish.
- DO NOT coat the product with any type of shine such as Tire Shine or glossy aerosol or gel. This can cause discoloration, staining or bubbling.

**1** Follow (Fig 1 – 10) to attach Spindle and Stiffening Bracket to Bumper, then attach Detent and Swing Arm. Ensure all fasteners are hand tightened.

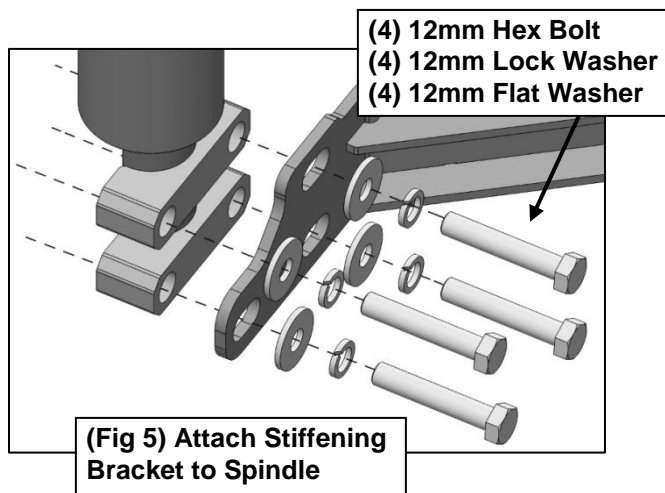
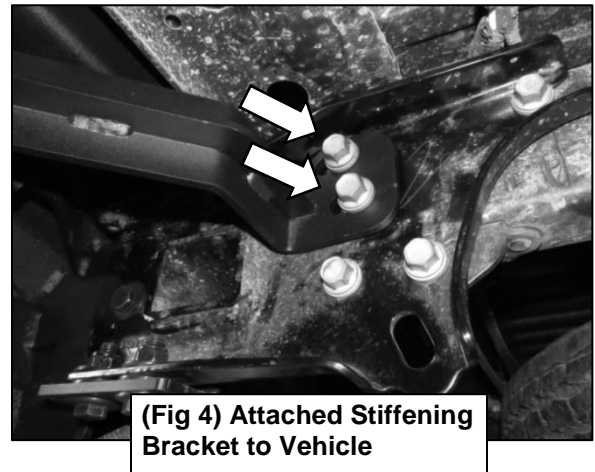
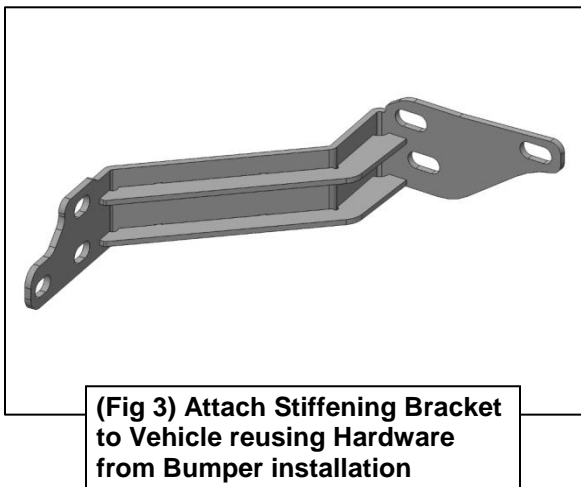
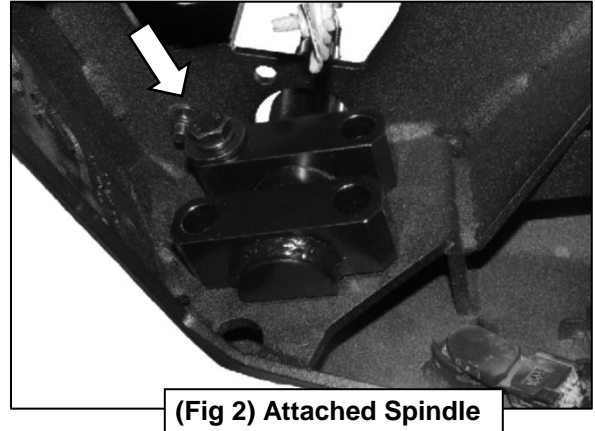
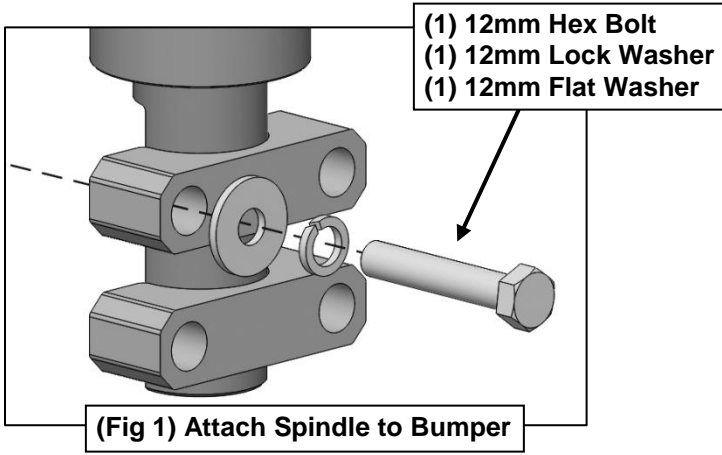



(Fig 7) Insert Plug into Bumper

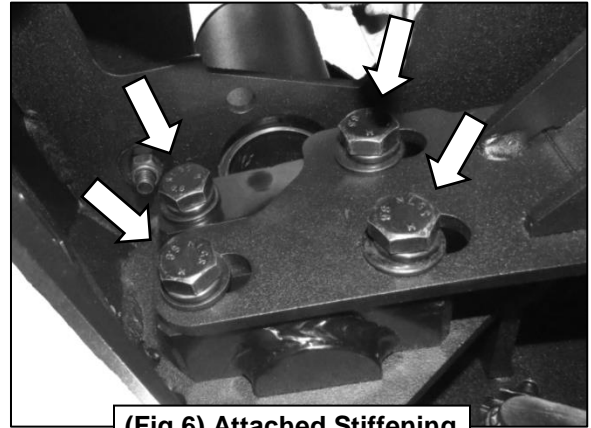

(Fig 6) Attached Stiffening Bracket and Spindle

- (1) 8x25mm Button Head Bolt
- (1) 8x16mm Flat Washer
- (1) Detent

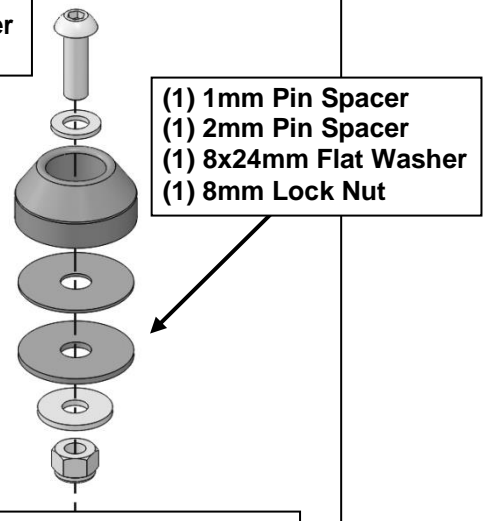

(Fig 8) Attach Detent to Bumper

- (1) Spindle Cap
- (1) Rubber Trim
- (1) 8x8mm Screw
- (1) Pin
- (1) 24mm Castle Nut
- (1) Bearing Retainer
- (1) Small NSK Bearing
- (1) Large NSK Bearing
- (1) Lower Bearing Seal

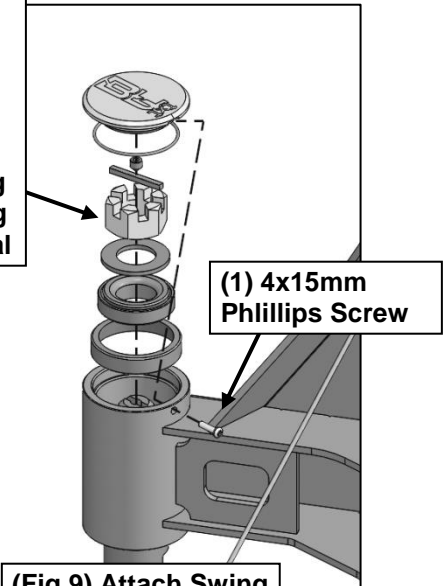

(Fig 9) Attach Swing Arm to Spindle

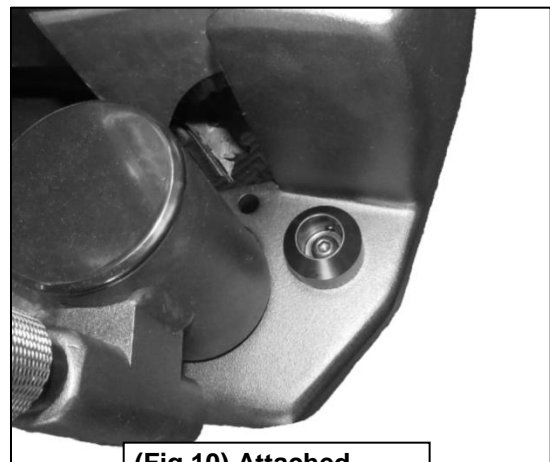

(Fig 10) Attached Detent and Swing Arm

**2** Follow (Fig 11 – 18) to attach Rubber Bumper Mounting Bracket and Rubber Bumpers, as well as Latch Mounting Bracket. Ensure all fasteners are hand tightened.

- (2) 8x20mm Button Head Bolt
- (4) 8x16mm Flat Washer
- (2) 8mm Lock Nut

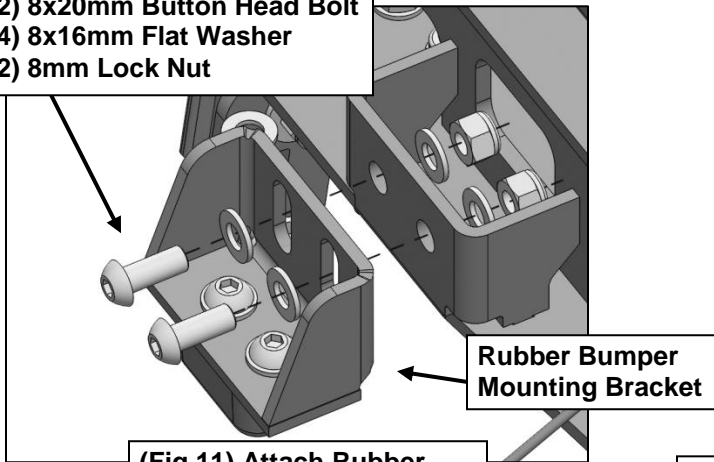

(Fig 11) Attach Rubber Bumper Mounting Bracket

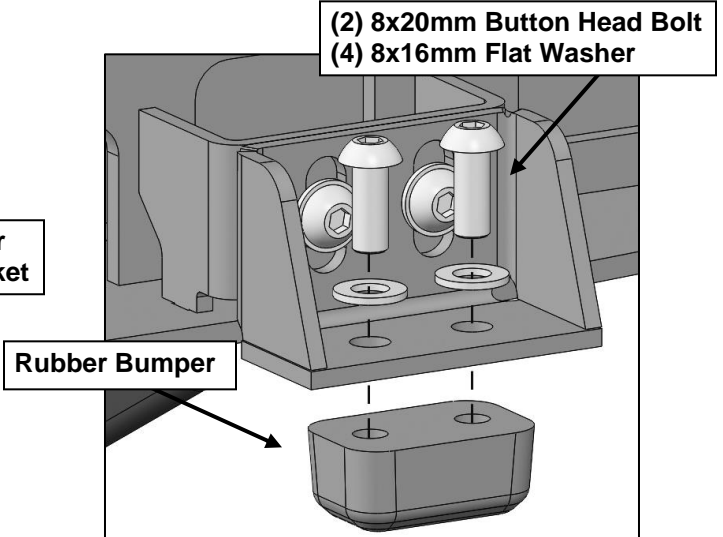

(Fig 12) Attach Rubber Bumper to Rubber Bumper Mounting Bracket

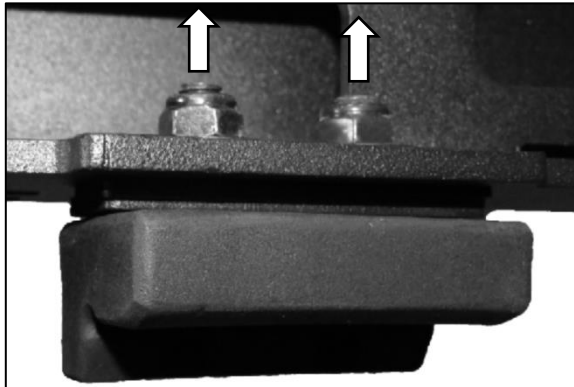

(Fig 13) Attached Rubber Bumper

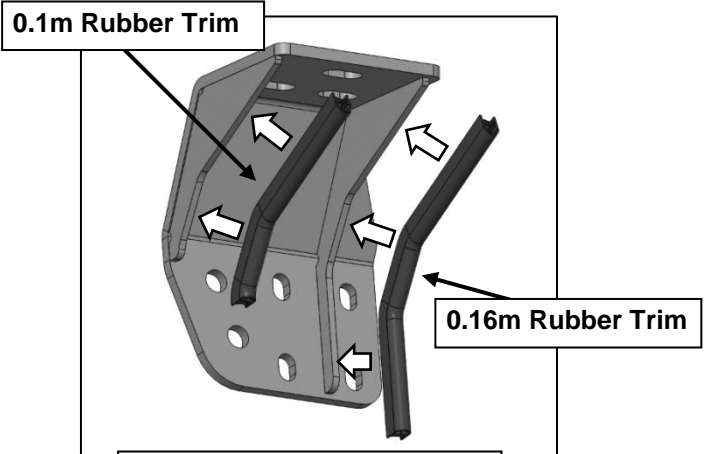

(Fig 14) Attach Rubber Trim to Latch Mounting Bracket

- (3) 8x25mm Hex Bolt
- (6) 8x16mm Flat Washer
- (3) 8mm Lock Nut

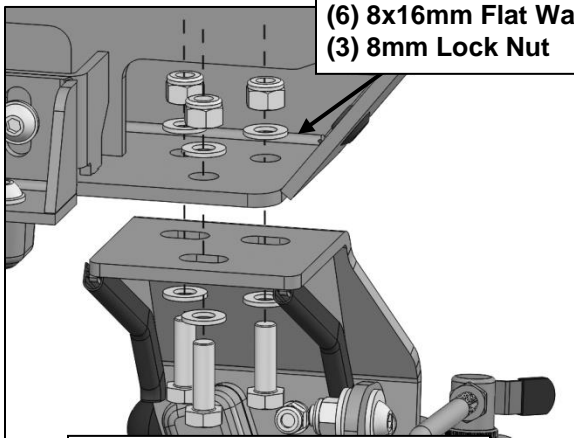

(Fig 15) Attach Latch Mounting Bracket to Swing Arm

- (2) 8x20mm Button Head Bolt
- (2) 8x16mm Flat Washer
- (1) 2mm Pin Spacer
- (1) 1mm Pin Spacer

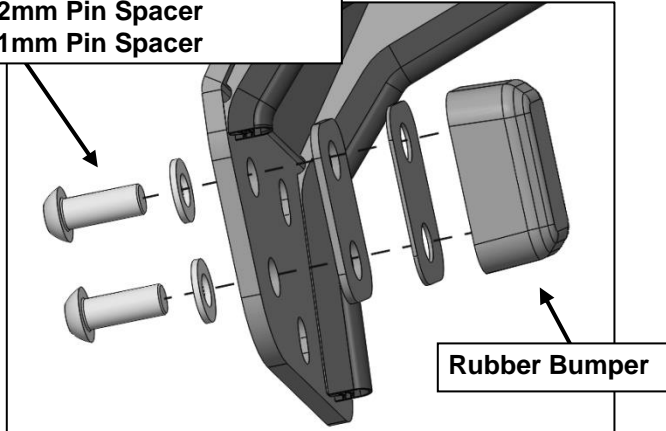

(Fig 17) Attach Rubber Bumper to Latch Mounting Bracket

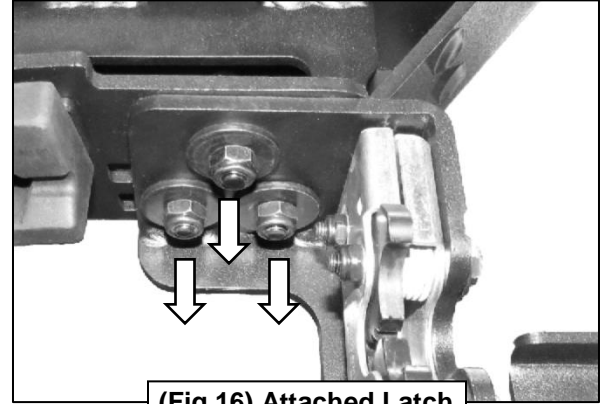

(Fig 16) Attached Latch Mounting Bracket

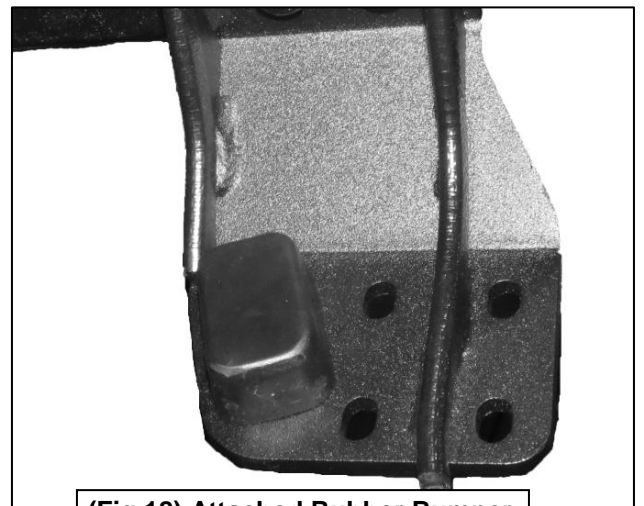

(Fig 18) Attached Rubber Bumper

**3** Follow (Fig 19 – 23) to attach Latch and Lock Catch to Swing Arm and Bumper. Ensure all fasteners are hand tightened.

- (4) 6x20mm Button Head Bolt
- (8) 6x12mm Flat Washer
- (4) 6mm Lock Nut

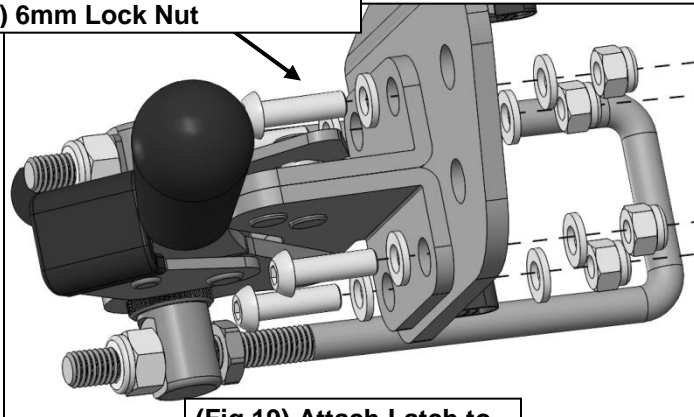

(Fig 19) Attach Latch to Latch Mounting Bracket

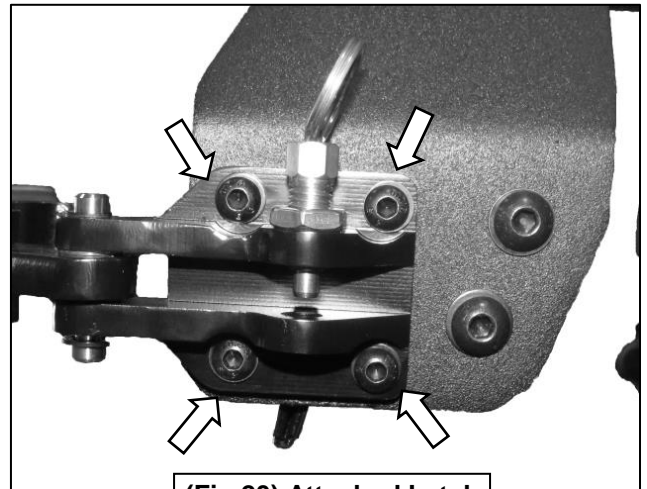

(Fig 20) Attached Latch



(Fig 21) Remove Plugs in Lock Catch installation point on Bumper



(Fig 23) Attached Lock Catch

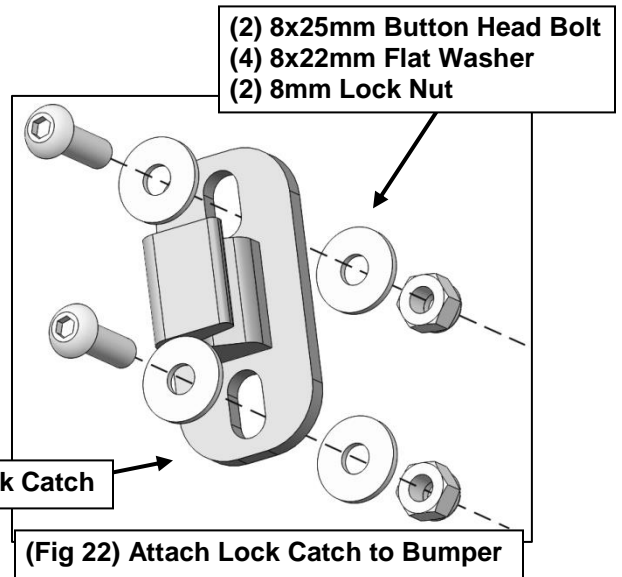

4

At this point, ensure Swing Arm is level, then tighten all fasteners. Installation is complete. Do periodic inspections to the installation to make sure that all hardware is secure and tight.



Completed Installation (Tire Carrier and DS Swing Arm Not)