

## 2018-2023 JEEP WRANGLER JL RTC REINFORCED TIRE CARRIER PART #JL-5290

### PARTS LIST:

1	Tire Carrier Offset Mounting Bracket	2	12-1.75mm x 30mm Hex Bolts
1	Door Reinforcement with Hinges	2	12mm x 37mm x 3mm Flat Washers
1	Inner Hinge Reinforcement Bracket	2	12mm Nylon Lock Nuts
2	Inner Hinge Reinforcement Shim Plates	4	10-1.5mm x 40mm Hex Bolts
1	Lower Tire Carrier Spacer Plate	4	10mm x 20mm x 2mm Flat Washers
1	Upper Tire Carrier Spacer Plate	4	10mm Lock Washers
1	Lower Spacer Foam Gasket	6	8-1.25mm x 45mm Hex Bolts
1	Upper Spacer Foam Gasket	12	8mm x 28mm x 3mm Large Flat Washers
1	Driver/left Brake Light Relocation Bracket	8	8mm x 16mm x 1.6mm Flat Washers
1	Passenger/right Brake Light Relocation Bracket	6	8mm Lock Washers
2	8mm x 20mm OD x 9mm Thick Spacers	8	8mm Nylon Lock Nuts
1	Driver/left Tall Bumper Mounting Cup	6	8mm Hex Nuts
1	Driver/left Tall Inner Bumper Mount	2	6-1.0mm x 30mm Hex Bolts
1	Passenger/right Short Bumper Mounting Cup	6	6mm x 30mm x 4mm Large Flat Washers
1	Passenger/right Short Inner Bumper Mount	2	6mm x 18mm x 1.6mm STD Flat Washers
4	6mm "T" Bolts	2	6mm Lock Washers
4	8mm Double Bolt Plates	2	6mm Hex Nuts
8	8mm Plastic Retainers		

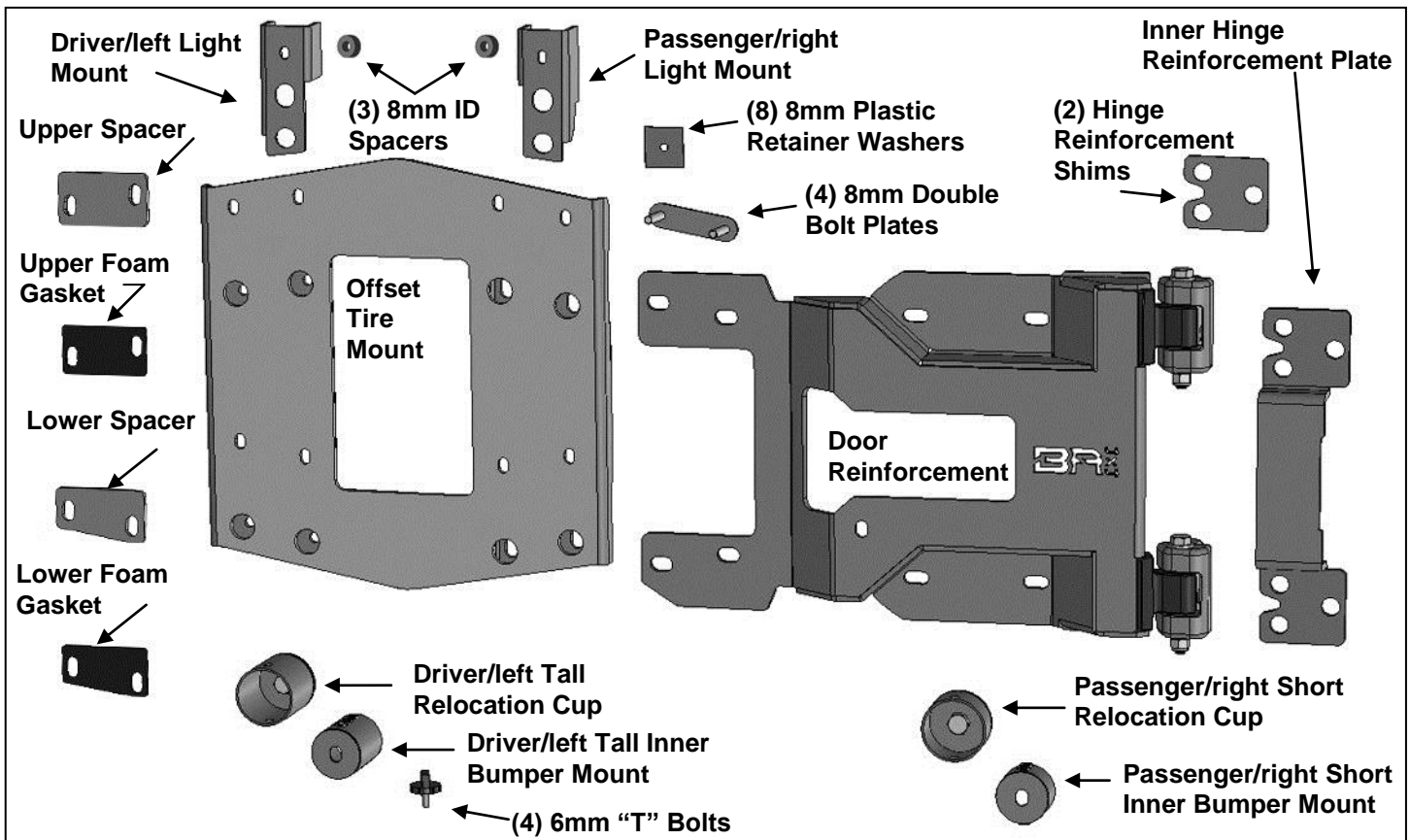



# INSTALLATION INSTRUCTIONS

## PROCEDURE:

**REMOVE CONTENTS FROM BOX. VERIFY ALL PARTS ARE PRESENT. READ INSTRUCTIONS CAREFULLY BEFORE STARTING INSTALLATION. ASSISTANCE IS HIGHLY RECOMMENDED.**

1. Open the rear door and remove the large plastic cover from the back of the door, **(Figure 1)**. Disconnect the wire harness leading to the CHMSL, (3rd brake light), and the camera if equipped. Pull the wire harness and grommet back through the outer door, **(Figure 2)**. Close the door.
2. Remove the spare tire and spare tire mount assembly with light and camera from the door, **(Figures 2 & 3)**. Remove both rubber bumpers from the door.
3. Next, reopen the door. Remove the bolt attaching the door stop check rod to the tailgate, **(Figure 4)**. Remove the plastic cover from the right side of the cargo area. With assistance, remove the (6) factory hinge bolts and pull the door out from the vehicle. Move the door to a stable work surface, **(Figure 5)**.
4. Remove the (2) factory hinges from the door, **(Figure 7)**.
5. Select the longer driver/left side Bumper Relocation Cup, **(Figure 6)**. Attach the Cup to the left side of the door with the included (1) 12mm x 30mm Hex Bolt, (1) 12mm Flat Washer and (1) 12mm Nylon Lock Nut. Fully tighten hardware. Insert the long Inner Bumper Mount into the outer Cup. Line up the threaded holes in the inner Mount with the holes in the outer Cup. Attach the Mount to the Cup with the included (2) "T" Bolts, **(Figure 7)**. Attach the factory rubber bumper to the adjustable Bumper Mount.
6. Unwrap the outer Door Reinforcement. Select the short passenger/right Bumper Relocation Cup, **(Figure 8)**. Attach the Cup to the outside of the Door Reinforcement with the included (1) 12mm x 30mm Hex Bolt, (1) 12mm Flat Washer and (1) 12mm Nylon Lock Nut. Fully tighten hardware. **NOTE:** Relocation Cup must be installed before installing Door Reinforcement assembly.
7. Insert the short Inner Bumper Mount into the outer Cup. Attach the inner Mount to the outer Cup with the included (2) "T" Bolts. Attach the factory rubber bumper to the adjustable Bumper Mount.
8. Carefully place the Door Reinforcement on the rear door over the (4) hinge mounting holes, **(Figure 9)**. Attach the Reinforcement assembly to the door with the included (4) 10mm x 40mm Hex Bolts, (4) 10mm Lock Washers and (4) 10mm Flat Washers, **(Figure 10)**. Do not fully tighten hardware.
9. With assistance, lift the rear door with Reinforcement up to the vehicle. Attach the hinges to the vehicle with the included longer (6) 8mm x 45mm Hex Bolts and (6) 8mm x 28mm Large Flat Washers, **(Figures 11 & 12)**. Properly align and adjust the rear door and fully tighten the inner and outer hinge bolts. Open and close door to check alignment and adjust if necessary. Reattach the door check rod.
10. Remove the retaining bolt and passenger/right taillight assembly, **(Figure 13)**. Place the inner Hinge Reinforcement Plate over the hex nuts for the top and bottom hinges. Slide (1) Shim Plate over the top hex nuts, **(Figures 14 & 15)**. Secure the Hinge Reinforcement and Shim with the included (3) 8mm x 28mm Large Flat Washers, (3) 8mm Lock Washers and (3) 8mm Hex Nuts, **(Figures 16 & 17)**. Repeat this Step to attach the lower end of the Reinforcement Plate and Shim Plate to the lower door hinge. Check the rear door alignment and operation and fully tighten Hinge Reinforcement hardware.
11. Select the Offset Tire Mount. Insert (1) Double Bolt Plate through the mounting holes in the back of the Mount, **(Figure 18)**. Thread (2) Plastic Retainers onto the Bolt Plate to hold the Bolt Plate in place, **(Figure 19)**. Repeat this Step to install the remaining (3) Bolt Plates.
12. Place the Tire Mount over the two right side mounting locations on the Reinforcement Plate. Reuse (4) factory bolts to attach the Tire Mount to the Reinforcement Plate and door, **(Figure 20)**. Leave loose.
13. Select the Top Spacer Plate. Apply the adhesive backed Top Foam Gasket to the back of the Spacer, **(Figure 20)**. **IMPORTANT:** Foam Gasket must install on side of Spacer in contact with rear door. Repeat this Step to apply the Foam Gasket to the Lower Spacer.
14. Slide the Top Spacer Plate between the top left side of the Tire Mount. Insert the remaining Lower Spacer between the bottom left side of the Tire Mount and the door. Reuse the (4) factory bolts to attach the left side of the Tire Mount to the Spacers and door, **(Figure 20)**. Align and adjust the Tire Mount and fully tighten hardware.
15. Slowly open the tailgate and check for proper operation. Adjust as needed and fully tighten all hardware. Close tailgate.

16. Move the factory spare tire mount with light mount to a stable work area.
17. Remove the light mount from the top of the tire mount, **(Figure 21)**. Select the driver/left Relocation Bracket, **(Figure 22)**. Attach the Bracket to the top of the tire mount with the included (1) 6mm x 30mm Hex Bolt, (1) 6mm x 30mm x 4mm Thick Flat Washer, (outer), (1) 6mm x 18mm STD Flat Washer, (inner), (1) 6mm Lock Washer and (1) 6mm Hex Nut. Repeat this Step to attach the passenger/right Relocation Bracket. Carefully tighten 6mm hardware to 7.5ft-lbs. (90in-lbs.).
18. Slide the upper light mount into the Relocation Brackets. Slide (1) 9mm thick Spacer between the inside of the top mounting hole on each Bracket and the top mounting hole in the light mount, **(Figure 23)**. Place (4) 6mm x 30mm x 4mm Thick Flat Washers over the (4) mounting holes in the Brackets. Reuse the factory screws to attach the light mount to the inside of the Brackets, **(Figure 23—25)**.
19. Attach the tire mount to the Bolt Plates in the Offset Bracket with the included (8) 8mm x 16mm Small Flat Washers and (8) 8mm Nylon Lock Nuts, **(Figure 26)**. Tighten hardware at this time.
20. Reinstall the factory wire harness. Plug the harness into the vehicle harness. Reinstall the taillight assembly and all plastic covers.
21. With assistance, attach the spare tire to the tire mount studs. Check the fit between the Rubber Bumpers and the tire. Adjust the Bumpers to provide a little preload against the tire, **(Figure 27)**. Tighten all hardware at this time.
22. Do periodic inspections to the installation to make sure that all hardware is secure and tight.

**To protect your investment**, do not use any type of polish or wax that may contain abrasives that could damage the finish. Mild soap may be used to clean Tire Mount.

## Installation Pictured

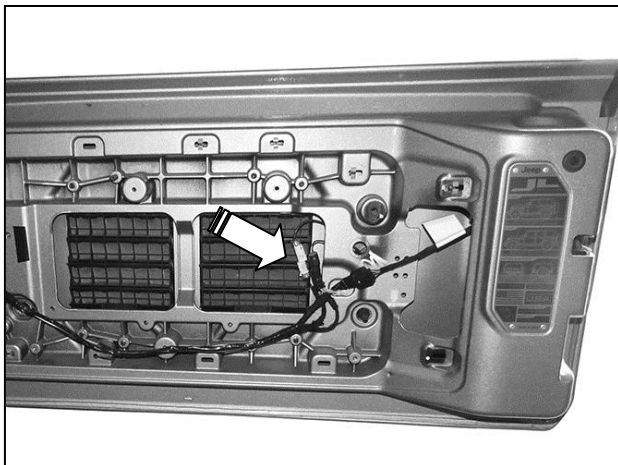

**(Fig 1)** Remove plastic cover from inside of door. Disconnect wire harnesses leading to the camera and CHMSL (3rd brake light)

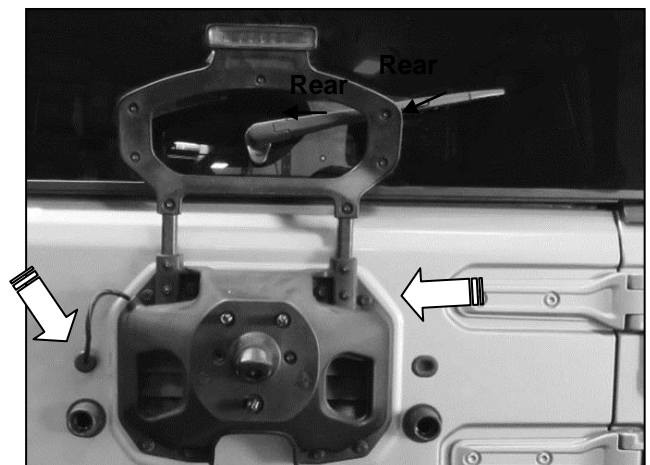

**(Fig 2)** Release rubber grommet (left arrow) and pull harness through hole in tailgate. Remove spare tire mount from rear door (arrow)



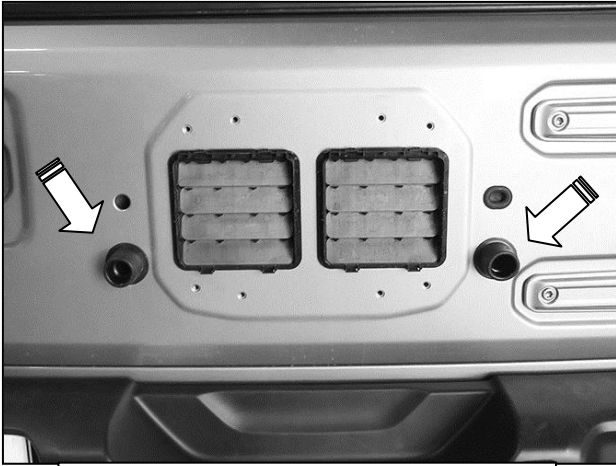

(Fig 3) Remove both rubber bumpers from rear door (arrows)

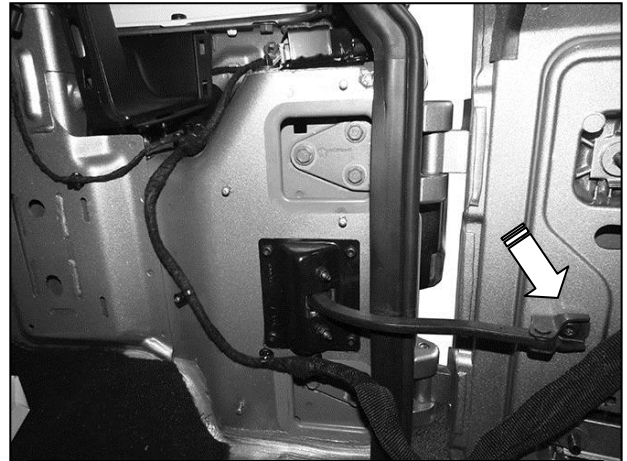

(Fig 4) Remove plastic panel from passenger/right side of cargo area. Release door check rod (arrow) and remove bolts from hinges to remove rear door

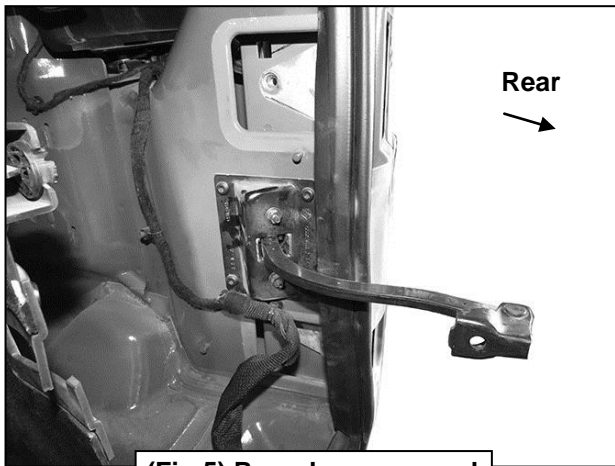

(Fig 5) Rear door removed

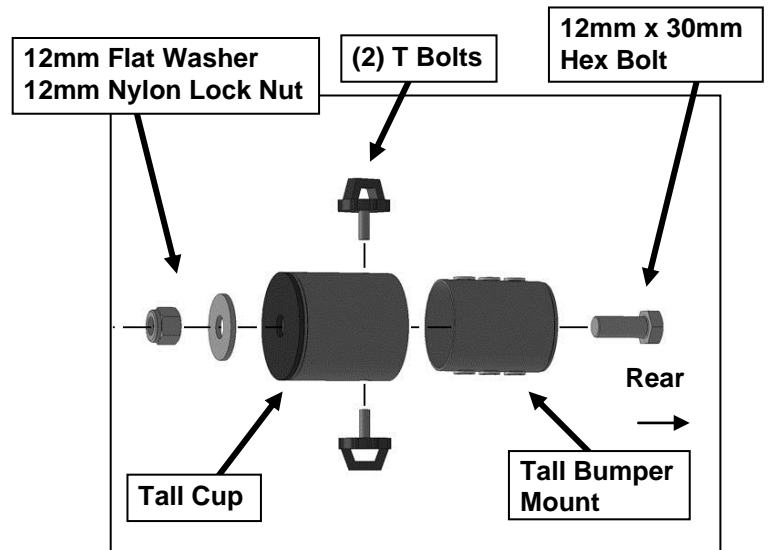

(Fig 6) Attach "Tall" rubber bumper Relocation Cup and Mount to bumper hole in driver/left side of rear door (figure 7)

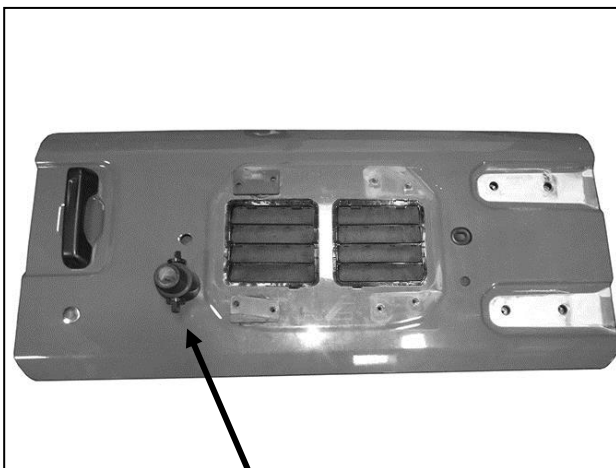

(Fig 7) "Tall" rubber bumper Relocation Cup and Mount installed

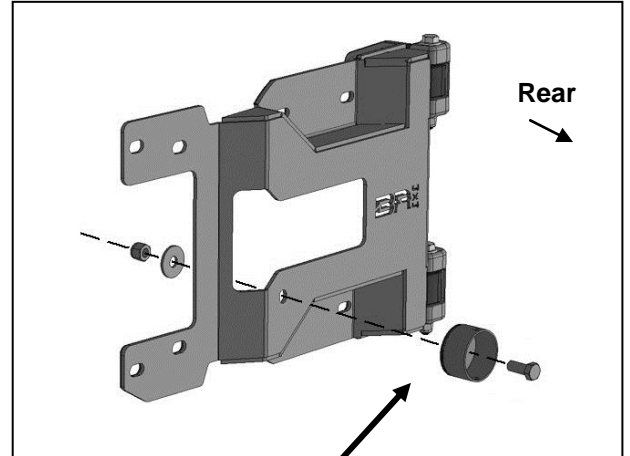

(Fig 8) Attach "Short" rubber bumper Relocation Cup and Mount to hole in Door Reinforcement

- (4) 10mm x 40mm Hex Bolts
- (4) 10mm Lock Washers
- (4) 10mm Flat Washers

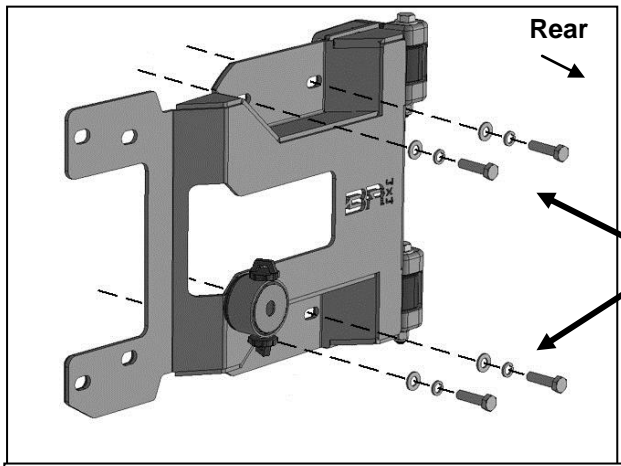

(Fig 9) Attach Door Reinforcement to rear door

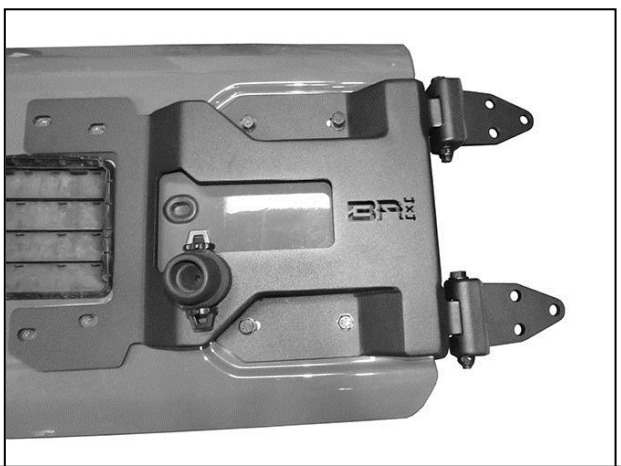

(Fig 10) Attach Door Reinforcement to rear door

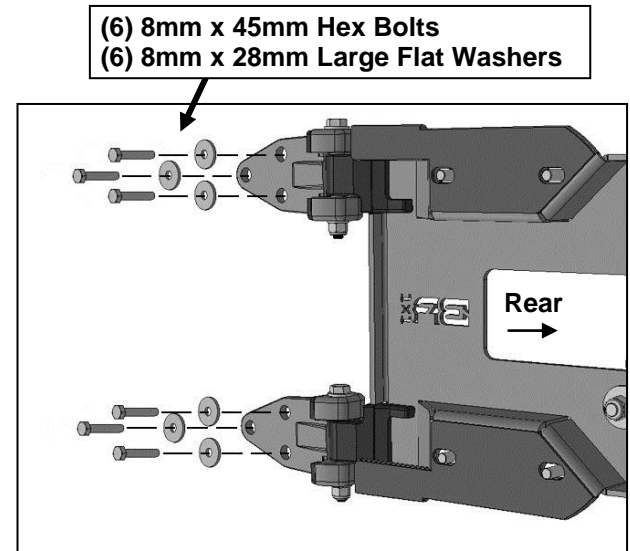

(Fig 11) Insert hinges on rear door into position and attach to inner body panel (figure 12)

- (6) 8mm x 45mm Hex Bolts
- (6) 8mm x 28mm Large Flat Washers



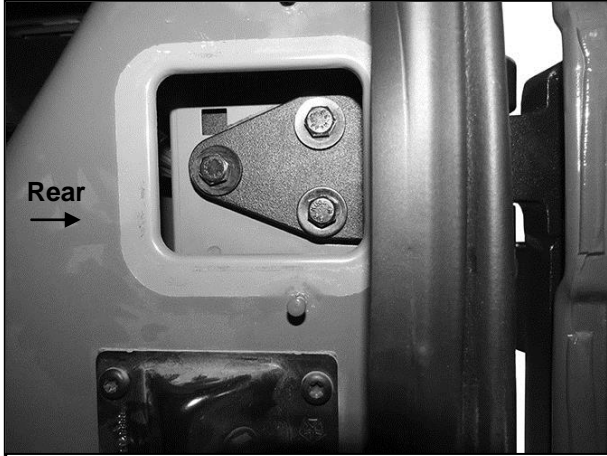

(Fig 12) Attach door hinges on Reinforcement assembly to body (top hinge pictured)

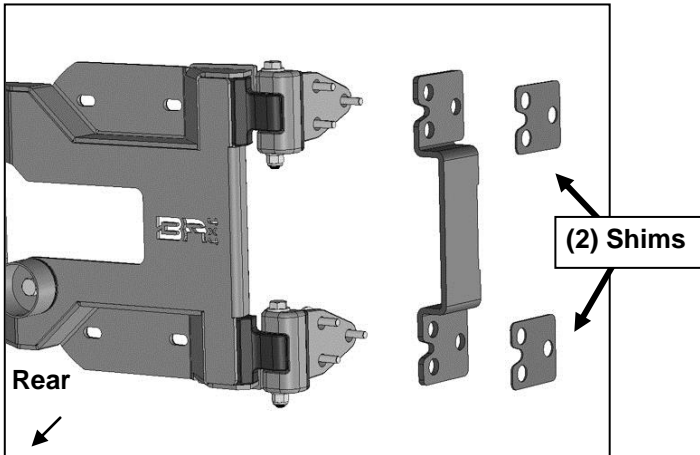

(Fig 14) Slide Inner Hinge Reinforcement Bracket and Shims over welded hex nuts on back of hinge mounting location (see figure 15)

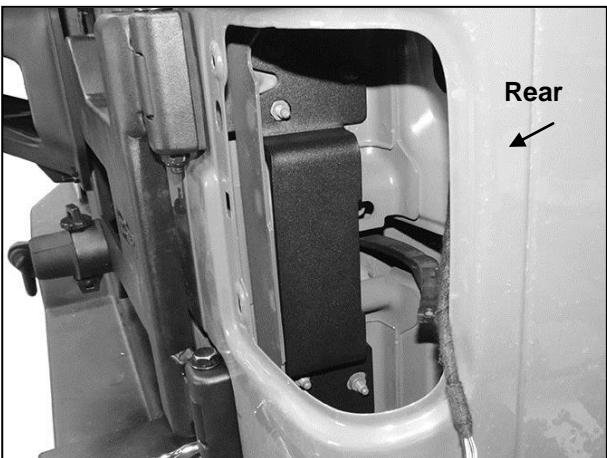

(Fig 15) Inner Hinge Reinforcement Bracket in place over welded hex nuts

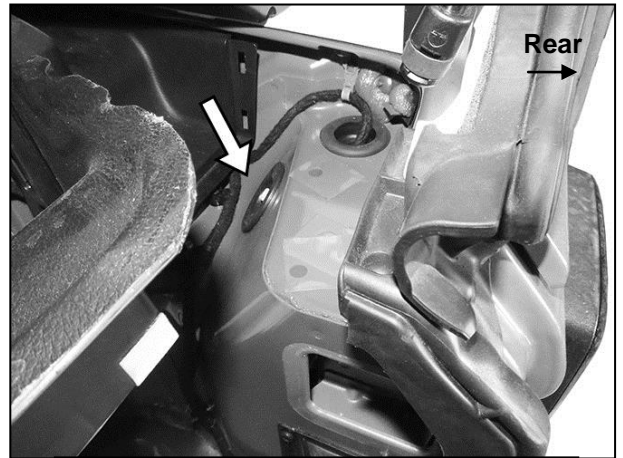

(Fig 13) Remove bolt (arrow) to remove passenger/right taillight assembly

- (6) 8mm x 28mm Large Flat Washers
- (6) 8mm Lock Washers
- (6) 8mm Hex Nuts

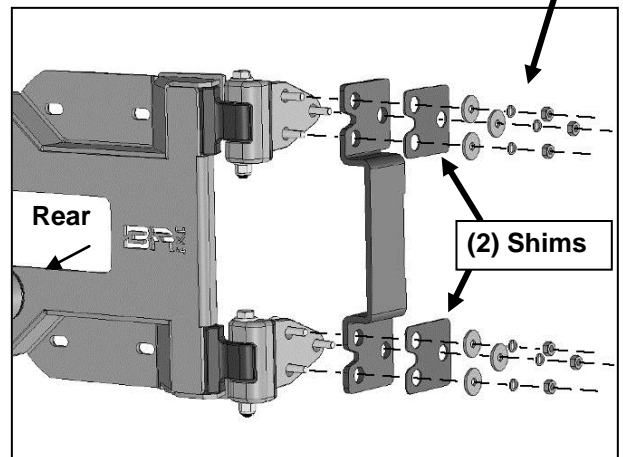

(Fig 16) Attach Inner Hinge Reinforcement Bracket and Shims to end of Hex Bolts

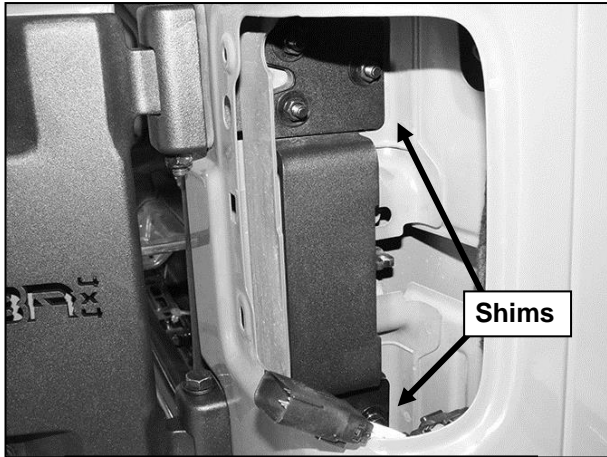

(Fig 17) Inner Hinge Reinforcement Bracket and Shims installed

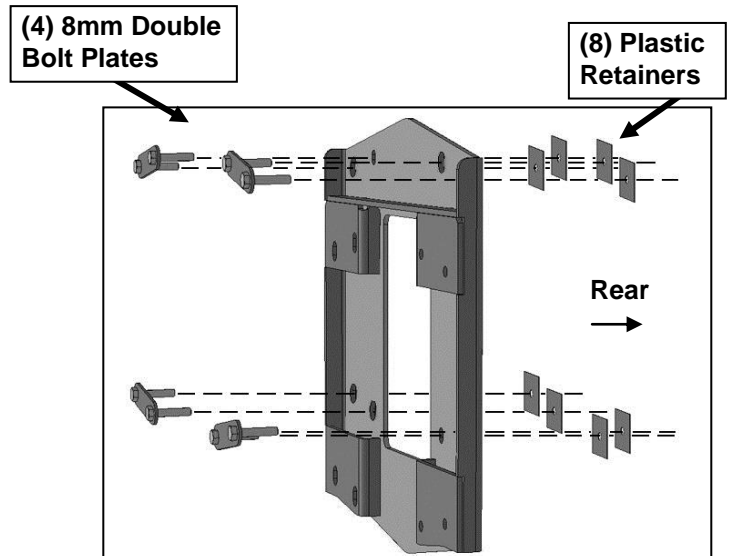

(Fig 18) Insert Double Bolt Plates through back of Offset Tire Mount Bracket. Secure Bolt Plates to Tire Mount with Plastic Retainers

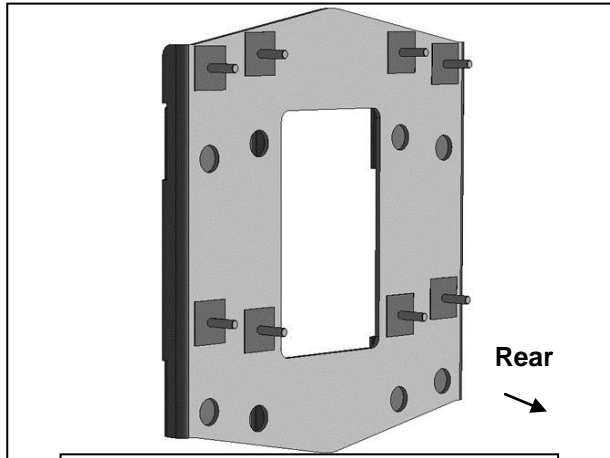

(Fig 19) Secure Bolt Plates to Tire Mount Bracket with Plastic Retainers

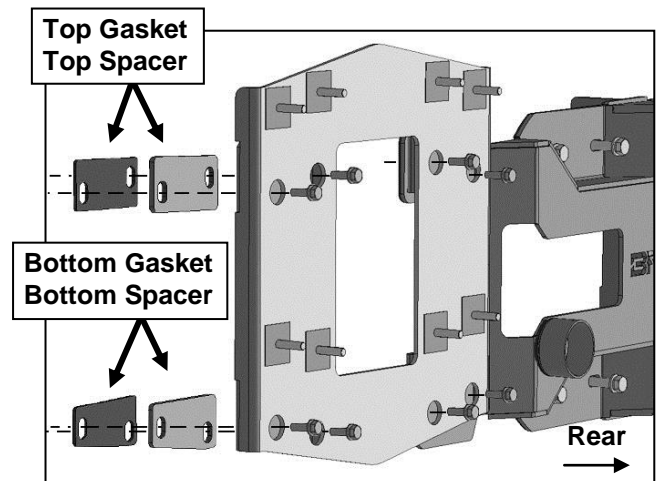

(Fig 20) Apply Foam Gaskets to back of Spacers. Reuse the factory bolts to attach the Mount Bracket to the door. Insert the Top and Bottom Spacers between the driver/left side of the Tire Mount Bracket and the door



(Fig 21) Remove the light bracket from the top of the factory tire mount

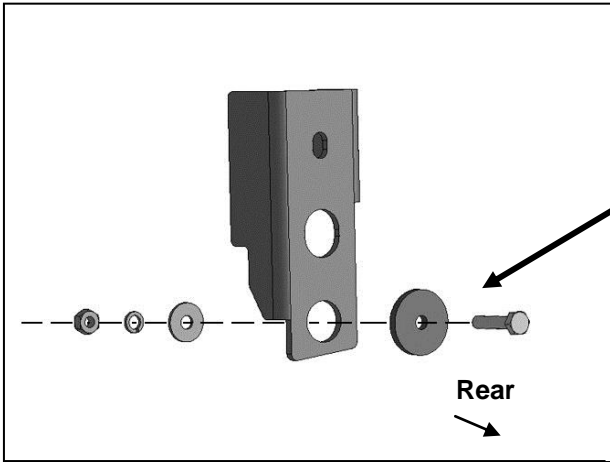

6mm x 30mm Hex Bolt  
 (1) 6mm x 30mm Large Flat Washer (outer)  
 (1) 6mm x 18mm STD Flat Washer (inner)  
 6mm Hex Nut

(Fig 22) Attach the driver/left Light Relocation Bracket to the top of the factory tire mount

Insert Spacer between Bracket and light mount

(2) 6mm x 30mm Large Flat Washers (outer)

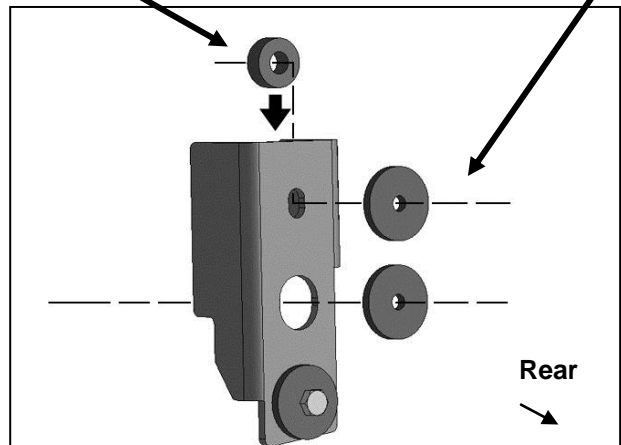

(Fig 23) Reuse factory screws to attach light mount to back of Relocation Brackets (figure 26)

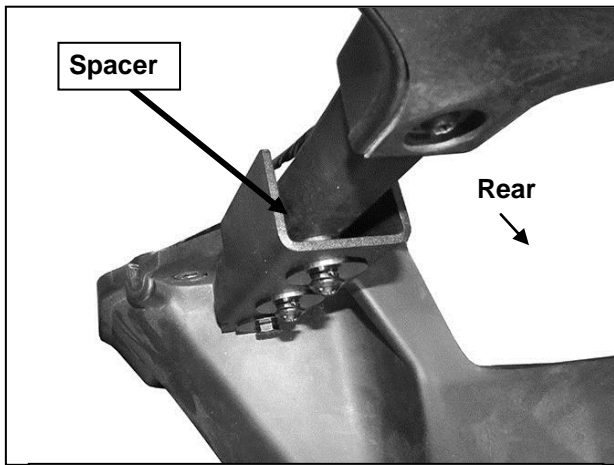

(Fig 24) Note Spacer inserted between top hole in Relocation Bracket and light mount

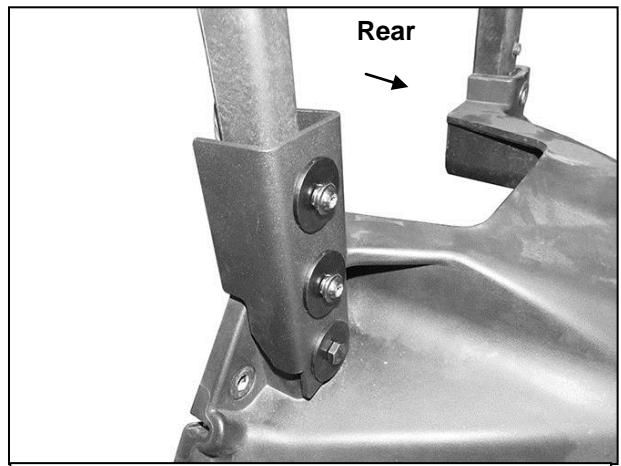

(Fig 25) Attach left and right Light Relocation Brackets to top of factory tire mount



(8) 8mm x 16mm Small Flat Washers  
(8) 8mm Nylon Lock Nuts

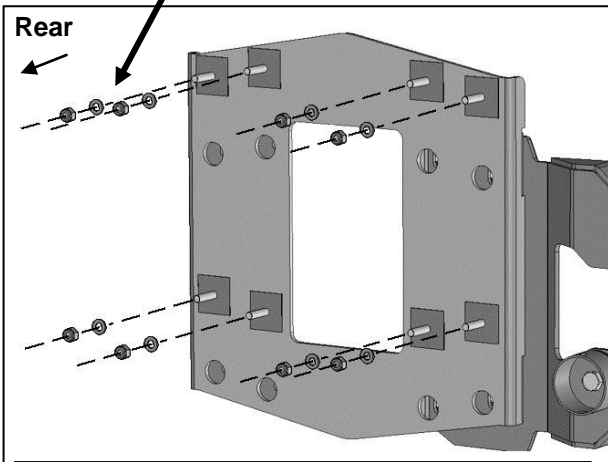

(Fig 26) Attach factory tire mount assembly with light to Offset Tire Mount Bracket

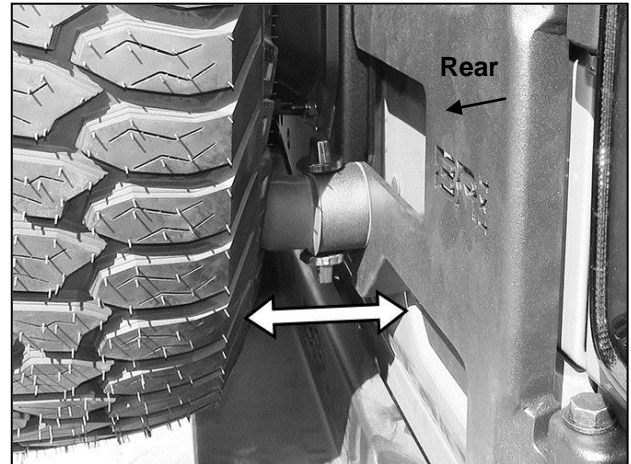

(Fig 27) Adjust height of Rubber Bumper relocation Brackets against tire