

2018-2023 CROSTREK REVO ROCK SLIDERS Part #SU-4125

PARTS LIST:

1	Driver/left Rock Slider	4	10-1.5mm x 30mm Hex Bolts
1	Passenger/right Rock Slider	20	10mm x 24mm x 2.2mm Flat Washers
2	Front Frame Mounting Brackets	12	10mm Lock Washers
2	Rear Frame Mounting Bracket	8	10mm Hex Nuts
2	Standard Rear Mounting Plates	8	8-1.25mm x 25mm Hex Bolts
2	Raised Adjustable Mounting Plates	8	8mm x 16mm x 1.6mm Flat Washers
2	Left Front-Right Rear Support Brackets	8	8mm Lock Washers
2	Right Front-Left Rear Support Brackets	8	8mm Flanged Hex Nuts
4	Rubber Bumpers	4	6-1.0mm x 25mm Button Head Bolts
4	14-1.5mm x 80mm Fine Thread Hex Bolts	8	6-1.0mm x 25mm Hex Bolts
4	14mm x 28mm x 2.5mm Flat Washers	24	6mm x 12mm x 1.6mm Flat washers
4	14mm Lock Washers	12	6mm Lock Washers
2	12mm x 35mm Countersunk Bolts	12	6mm Hex Nuts
4	10-1.25mm x 80mm Fine Thread Hex Bolts	1	8mm Wrench
4	10-1.5mm x 55mm Hex Bolts	1	4mm Wrench

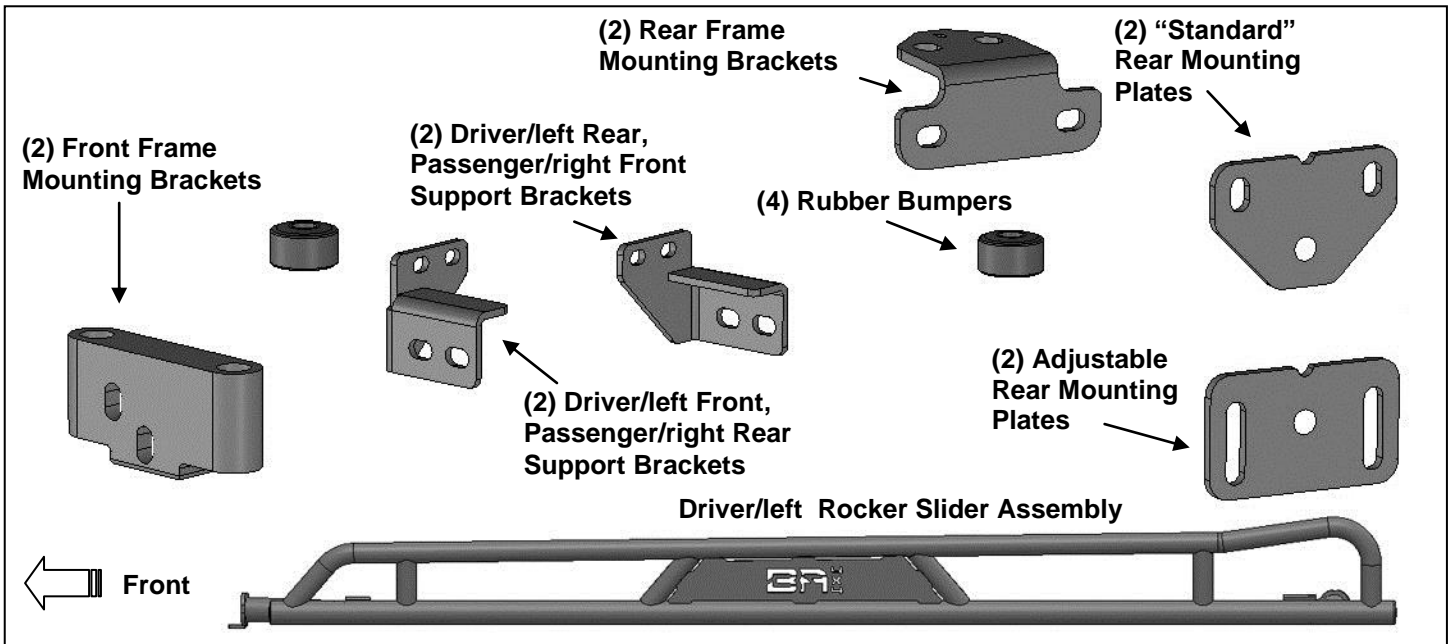

PROCEDURE:

REMOVE CONTENTS FROM BOX. VERIFY ALL PARTS ARE PRESENT. READ INSTRUCTIONS CAREFULLY BEFORE STARTING INSTALLATION. ASSISTANCE IS RECOMMENDED. DRILLING IS REQUIRED. CUTTING MAY BE REQUIRED.

1. Start installation along the driver/left side of the vehicle. Remove the (2) factory hex bolts from the bottom of the front suspension mount, **(Figure 1)**. Select (1) Front Frame Bracket, **(Figure 2)**. Attach the Frame Bracket to the threaded holes with the included (2) 14mm x 80mm Special Fine Thread Hex Bolts, (2) 14mm Lock Washers and (2) 14mm Flat Washers,

(Figures 2 & 3). Do not fully tighten hex bolts at this time.

2. Move toward the rear of the vehicle. Determine if the vehicle has stock/original suspension, (Figure 4), or if the rear suspension mount has an added aftermarket spacer block for additional ground clearance, (Figure 7). **IMPORTANT:** It may be necessary to cut the plastic cover to clear the rear Bracket.

Original suspension (no spacer).

- a. Reuse the (2) factory hex bolts to attach (1) Rear Frame Bracket to the (2) threaded holes, (Figures 5 & 6).

Lifted suspension (aftermarket spacer block added).

- a. Remove the (2) hex bolts, (Figure 7). Select (1) Rear Frame Bracket, (Figure 8).
- b. Attach the Bracket to the spacer and the vehicle with the included (2) 10mm x 80mm Special Fine Thread Hex Bolts, (2) 10mm Lock Washers and (2) 10mm Flat Washers, (Figures 8 & 9). Do not fully tighten hardware at this time.

3. Carefully unwrap the Rocker Sliders. Select the driver/left Rocker Slider. Attach (1) Rubber Bumper to the front mounting tab on Rocker Slider with the included (1) 6mm x 25mm Button Head Bolt, (2) 6mm Flat Washers, (1) 6mm Lock Washer and (1) 6mm Hex Nut, (Figure 10). Repeat this **Step** to attach (1) Rubber Bumper to the rear mounting tab on the Rocker Slider, (Figure 11). Tighten the hardware attaching the Rubber Bumpers
4. Determine if the vehicle has stock/original suspension or if the rear suspension mount has an added aftermarket spacer block for additional ground clearance.

Models with stock or original suspension.

- a. Attach the (1) Standard Rear Mounting Plate to the end of the Rocker Slider with (1) 12mm x 35mm Countersunk Bolt, (Figure 12).

Models with lifted suspension and spacer.

- a. Attach (1) Adjustable Rear Mounting Plate to the end of the Rocker Slider with (1) 12mm x 35mm Countersunk Bolt, (Figure 13). **NOTE:** Install Adjustable Plate with ID notch at the top.

5. Hold the Rocker Slider up to the Front Frame Bracket. Attach the front of the Rocker Slider to the Frame Bracket with (2) 10mm x 55mm Hex Bolts, (4) 10mm Flat Washers, (2) 10mm Lock Washers and (2) 10mm Hex Nuts, (Figures 14 & 15). Leave hardware loose.
6. Move to the rear of the Rocker Slider. Attach the rear Mounting Plate on the Rocker Slider to the rear Frame Bracket with the included (2) 10mm x 30mm Hex Bolts, (4) 10mm Flat Washers, (2) 10mm Lock Washers and (2) 10mm Hex Nuts, (Figures 16—18).
7. Select the driver/front Support Bracket. Attach the Bracket to the mount on the front end of the Rock Slider with the included (2) 8mm x 25mm Hex Bolts, (2) 8mm Lock Washers, (2) 8mm Flat Washers and (2) 8mm Flange Nuts, (Figure 19). Repeat this **Step** to attach the driver/left Rear Support Bracket, (Figure 20). Do not fully tighten hardware.
8. Line up the Support Brackets with the outside of the pinch weld. Mark the location of the holes in the front and rear Support Brackets onto the pinch weld, (Figures 21—23). Temporarily remove the Rock Slider.
9. Use a 5/16" drill bit and drill holes through the pinch weld at the previously marked locations. **NOTE:** Paint all bare metal surfaces to prevent rust, (Figures 22 & 23).
10. Reinstall the Rocker Slider. Attach the front and rear Support Brackets to the pinch weld with the included (4) 6mm x 25mm Hex Bolts, (8) 6mm Flat Washers, (4) 6mm Lock Washers and (4) 6mm Hex Nuts, (Figures 24—27).
11. Align and adjust the Rocker Slider and fully tighten all hardware.

12. Repeat **Steps 1—11** to install the passenger/right Rocker Slider.

13. Do periodic inspections to the installation to make sure that all hardware is secure and tight. **To protect your investment**, Do not use any type of polish or wax that may contain abrasives that could damage the finish. Mild soap may be used to clean the Rocker Sliders.

Driver/left side Installation Pictured

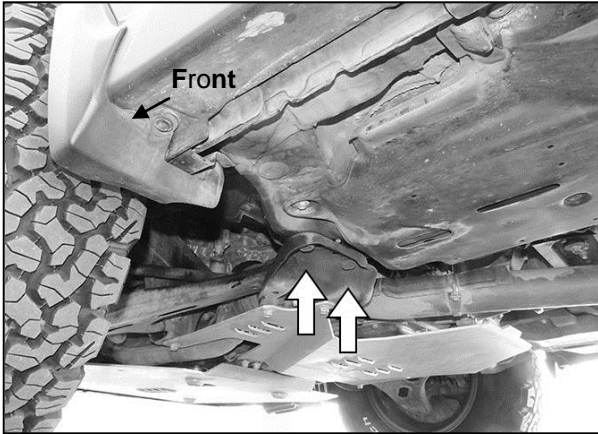

(Fig 1) Remove (2) factory hex bolts (arrows). Driver/left front pictured

- (2) 14mm x 80mm Fine Thread Hex Bolts
- (2) 14mm Lock Washers
- (2) 14mm Flat Washers

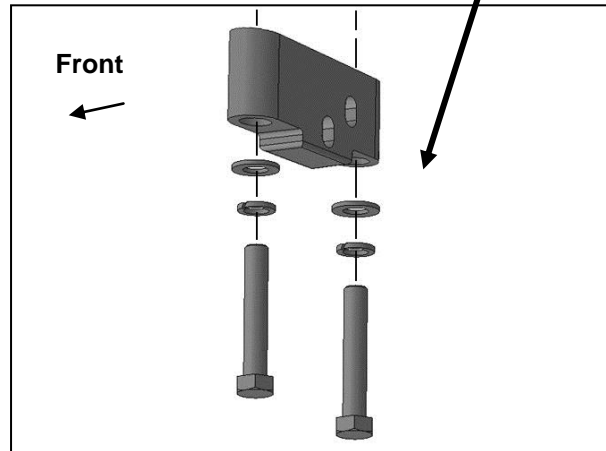

(Fig 2) Attach Front Frame Bracket to driver/left front mounting location (see Fig 1)

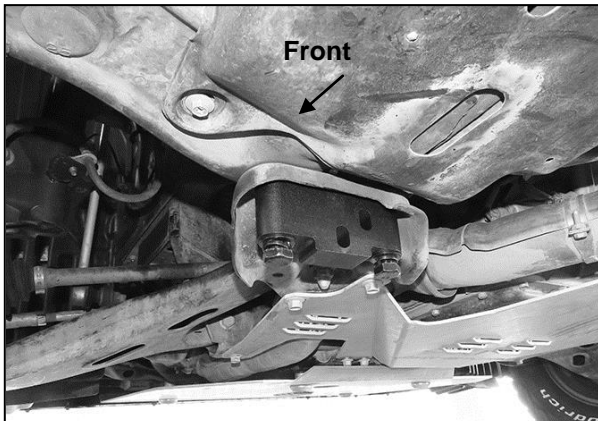

(Fig 3) Driver/left Front Frame Bracket installed

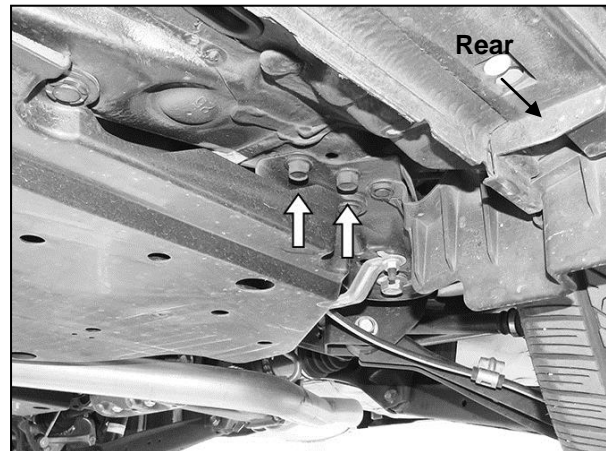

(Fig 4) Rear mounting location pictured on model without suspension lift "spacer." Remove (2) factory hex bolts (arrows)

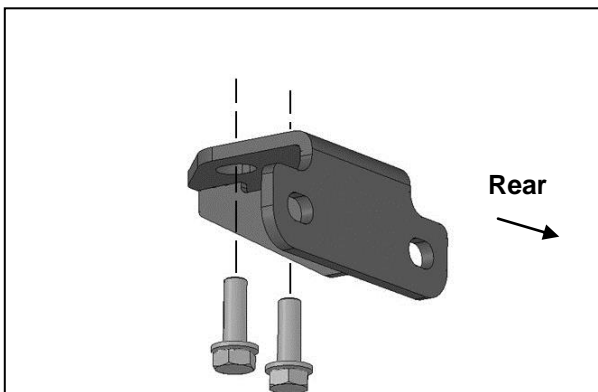

(Fig 5) Models without suspension lift "spacer," reuse factory hex bolts to attach rear Frame Mounting Bracket

Driver/left side Installation Pictured



(Fig 6) Driver/left rear Mounting Bracket installed on model with "stock" suspension, no suspension lift spacer.

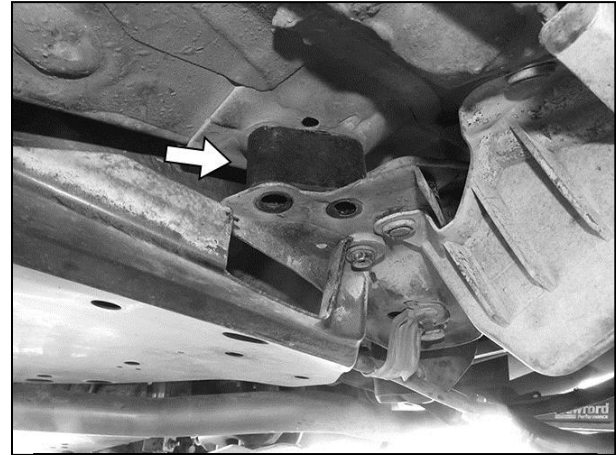

(Fig 7) Example of model with aftermarket suspension lift "spacer" (arrow)

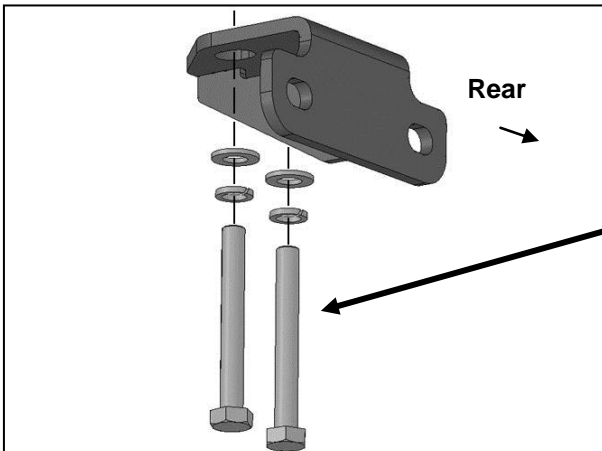

(Fig 8) Models with suspension lift "spacer," use the included longer Hex Bolts

- (2) 10mm x 80mm Fine Thread Hex Bolts
- (2) 10mm Lock Washers
- (2) 10mm Flat Washers



(Fig 9) Driver/left rear Bracket installed over aftermarket suspension lift spacer.

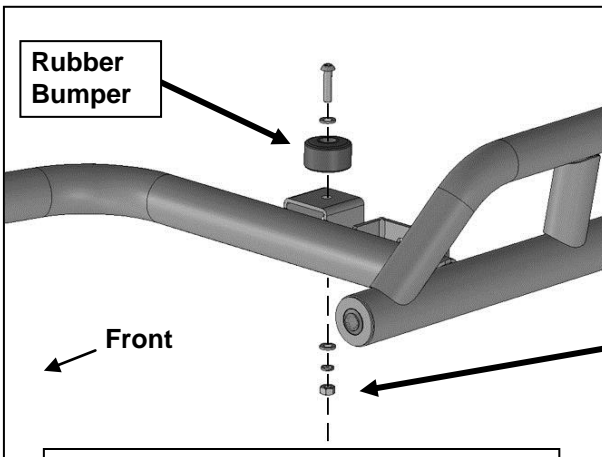

(Fig 10) Attach Rubber Bumper to front mounting tab on Rocker Sliders

- 6mm x 25mm Button Head Bolt
- (2) 6mm Flat Washers
- 6mm Lock Washer
- 6mm Hex Nut

Driver/left side Installation Pictured

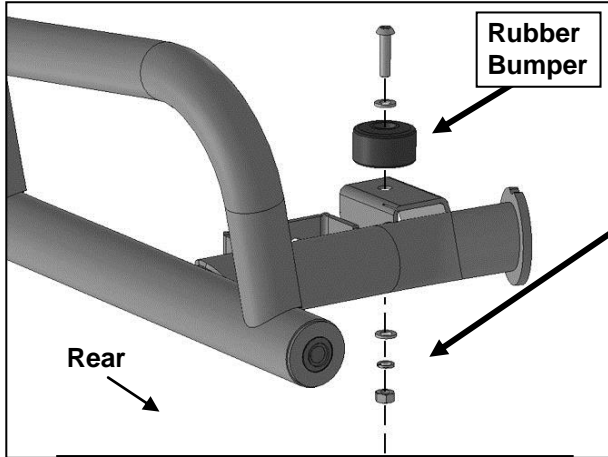

(Fig 11) Attach Rubber Bumper to rear mounting tab on Rocker Sliders

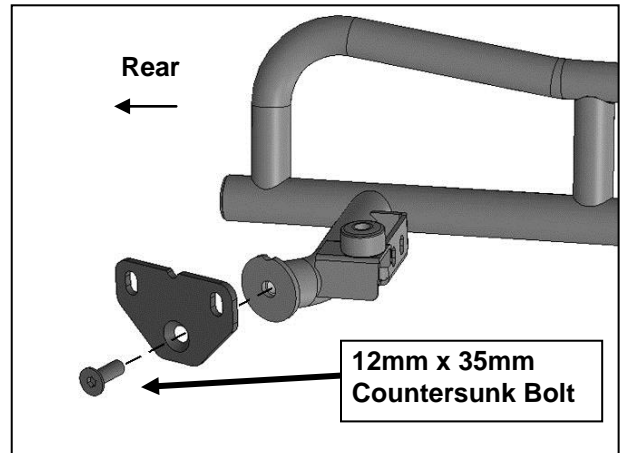

(Fig 12) Models without aftermarket suspension lift "spacer," attach Standard Mounting Plate to end of Rocker Slider

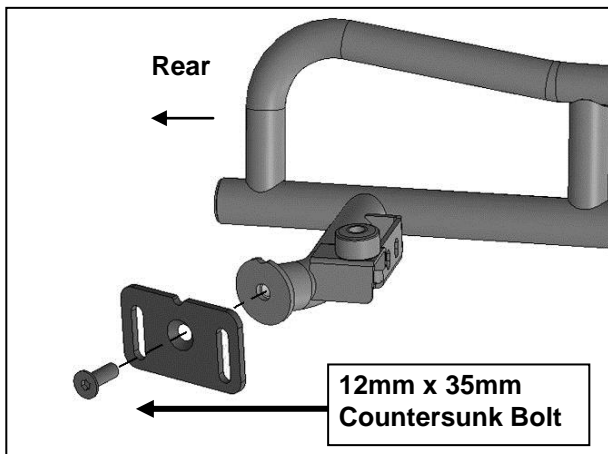

(Fig 13) Models with suspension lift "spacer," attach Adjustable Mounting Plate

- (2) 10mm x 55mm Hex Bolts
- (4) 10mm Flat Washers
- (2) 10mm Lock Washers
- (2) 10mm Hex Nuts

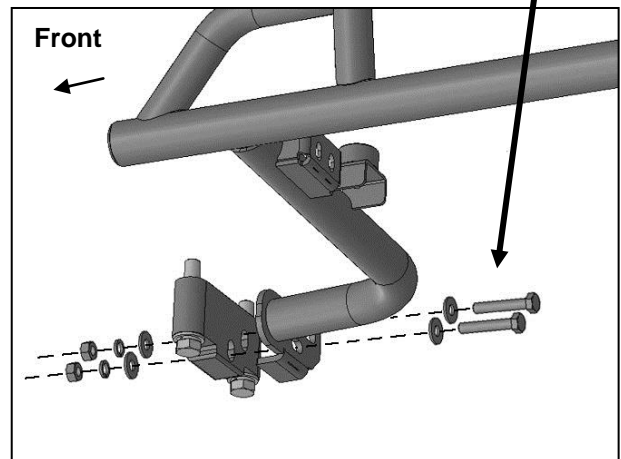

(Fig 14) Attach front of Rocker Slider to front Frame Mounting Bracket

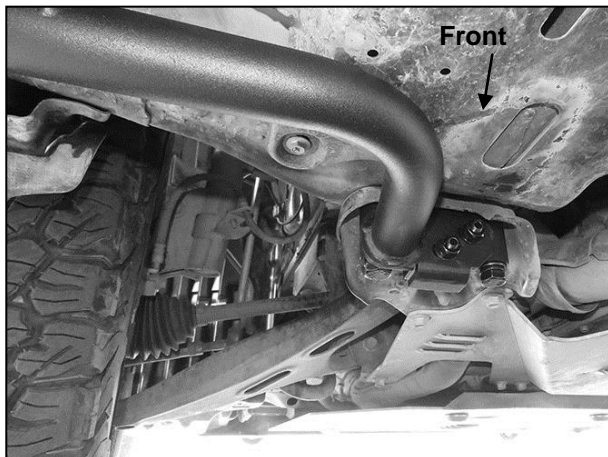

(Fig 15) Attach front of Rocker Slider to front Frame Mounting Bracket

Driver/left side Installation Pictured

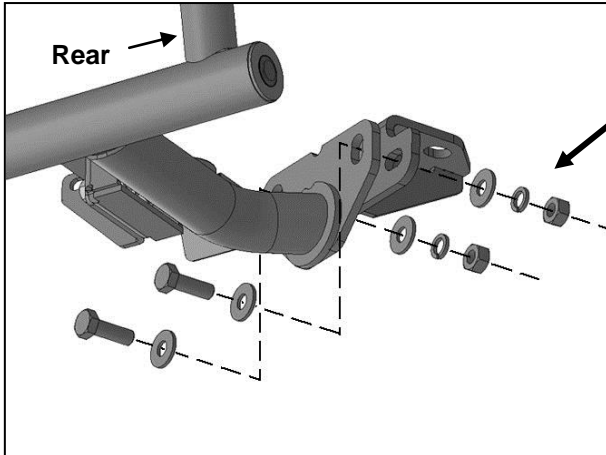

- (2) 10mm x 30mm Hex Bolts
- (4) 10mm Flat Washers
- (2) 10mm Lock Washers
- (2) 10mm Hex Nuts

(Fig 16) Models with "stock" suspension, (without suspension lift spacer), attach Standard Mounting Plate on Rocker Slider to Frame Bracket

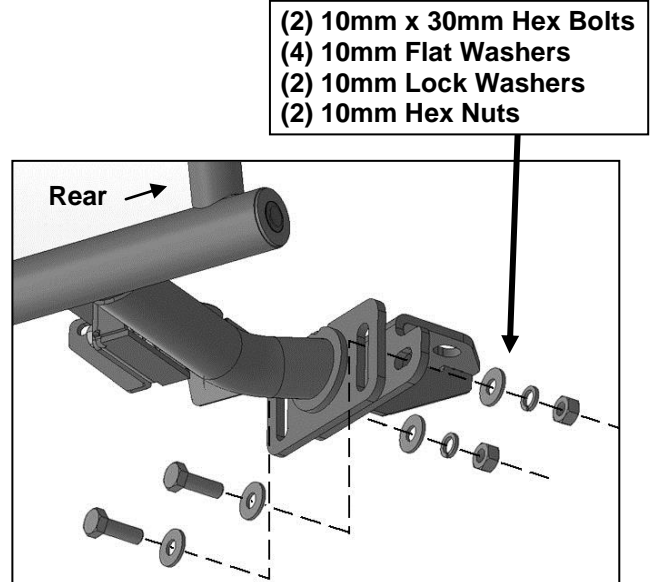

- (2) 10mm x 30mm Hex Bolts
- (4) 10mm Flat Washers
- (2) 10mm Lock Washers
- (2) 10mm Hex Nuts

(Fig 17) Models with suspension lift "spacer," attach Adjustable Mounting Plate on end of Rocker Slider to rear Frame Bracket



(Fig 18) Models with suspension lift "spacer," attach Adjustable Mounting Plate on end of Rocker Slider to rear Frame Bracket

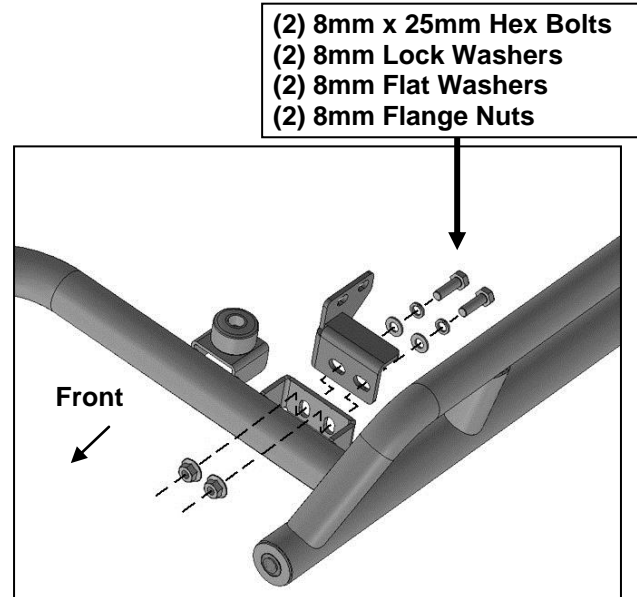

- (2) 8mm x 25mm Hex Bolts
- (2) 8mm Lock Washers
- (2) 8mm Flat Washers
- (2) 8mm Flange Nuts

(Fig 19) Attach driver/left front Support Bracket to front end of Rocker Slider

Driver/left side Installation Pictured

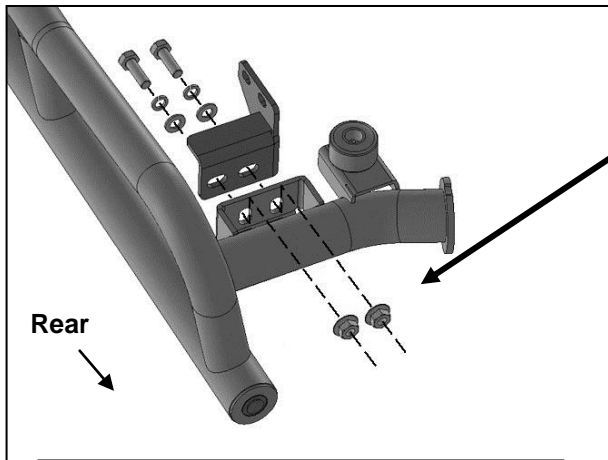

- (2) 8mm x 25mm Hex Bolts
- (2) 8mm Lock Washers
- (2) 8mm Flat Washers
- (2) 8mm Flange Nuts

(Fig 20) Attach driver/left rear Support Bracket to rear end of Rocker Slider

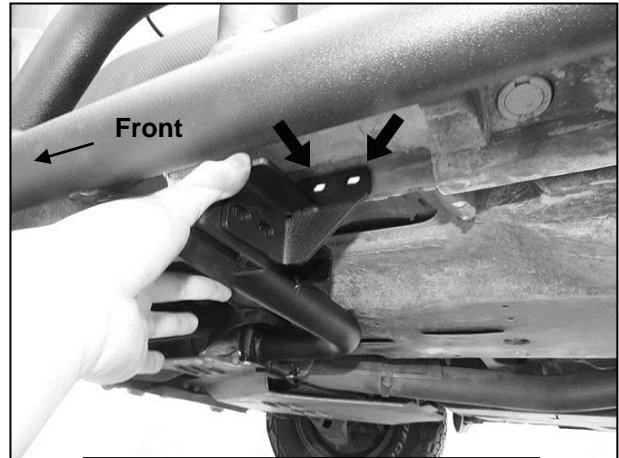

(Fig 21) Mark location of holes in Support Bracket onto pinch weld (driver/left front location pictured)

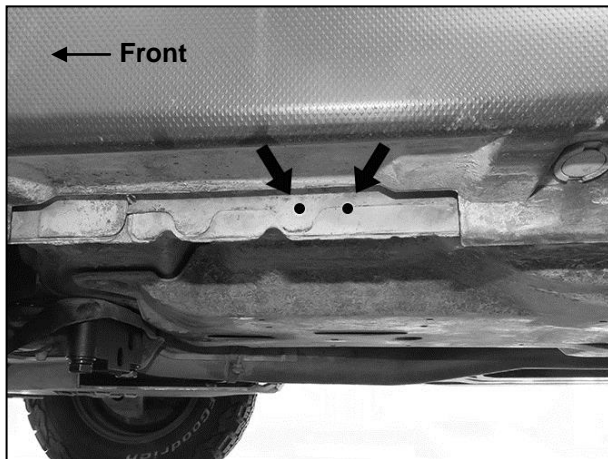

(Fig 22) Temporarily remove the Rocker Slider. Drill 5/16" holes through pinch weld. Driver/left front location pictured

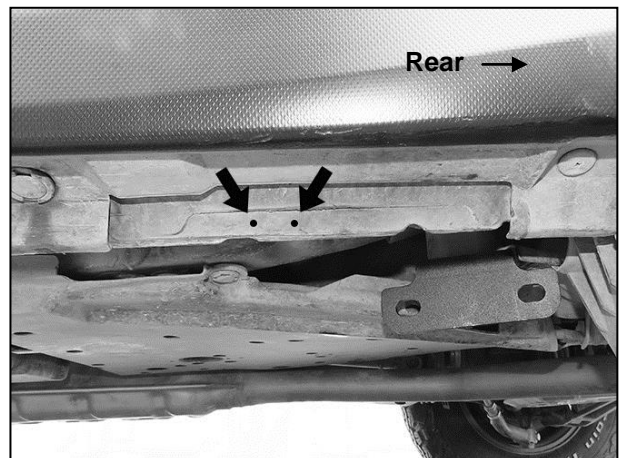

(Fig 23) Drill 5/16" holes through pinch weld. Driver/left rear location pictured. Apply paint (not included) to all bare metal surfaces

Driver/left side Installation Pictured

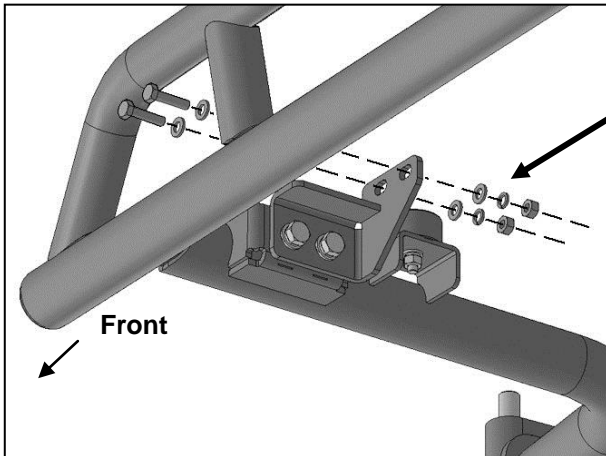

(Fig 24) Reinstall Rocker Slider. Attach Support Bracket to outside of pinch weld

- (2) 6mm x 25mm Hex Bolts
- (4) 6mm Flat Washers
- (2) 6mm Lock Washers
- (2) 6mm Hex Nuts

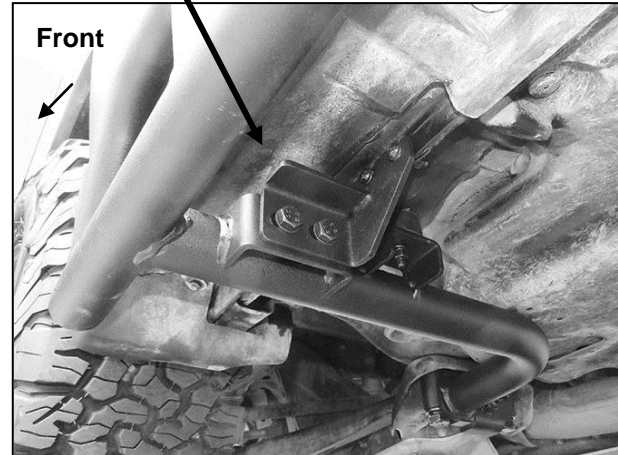

(Fig 25) Driver/left front complete installation

- (2) 6mm x 25mm Hex Bolts
- (4) 6mm Flat Washers
- (2) 6mm Lock Washers
- (2) 6mm Hex Nuts

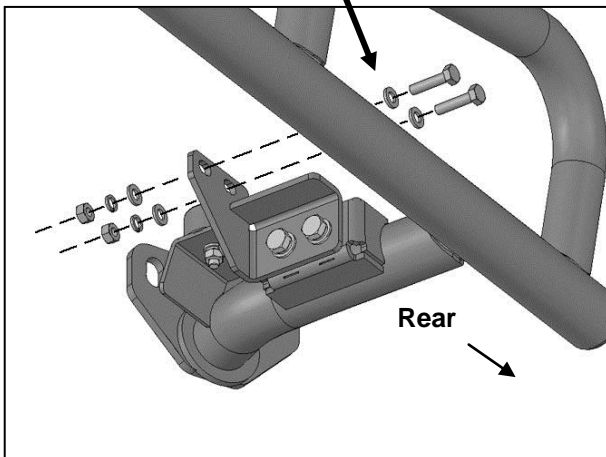

(Fig 26) Attach driver/left rear Support Bracket to outside of pinch weld, (stock height suspension installation illustrated)

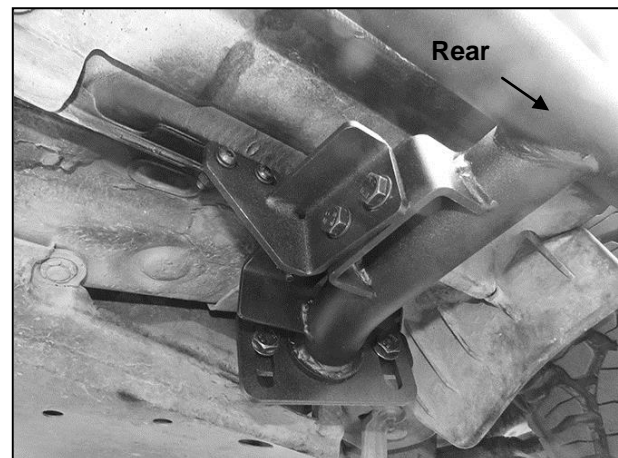

(Fig 27) Driver/left rear with spacer, (raised suspension), complete installation pictured