

2009-2014 FORD F-150 ECO SERIES REAR BUMPER PART #FD-2963

PARTS LIST:

1	LD1 Rear Bumper Assembly	1	Sensor Covers Kit
2	Plastic Plugs for license plate mount	8	4mm Self Tapping Screws
4	Sensor Hole Plugs	1	4mm Wrench
4	15.5mm x 25mm x 2mm Foam Washers	10	Nylon Wire Ties

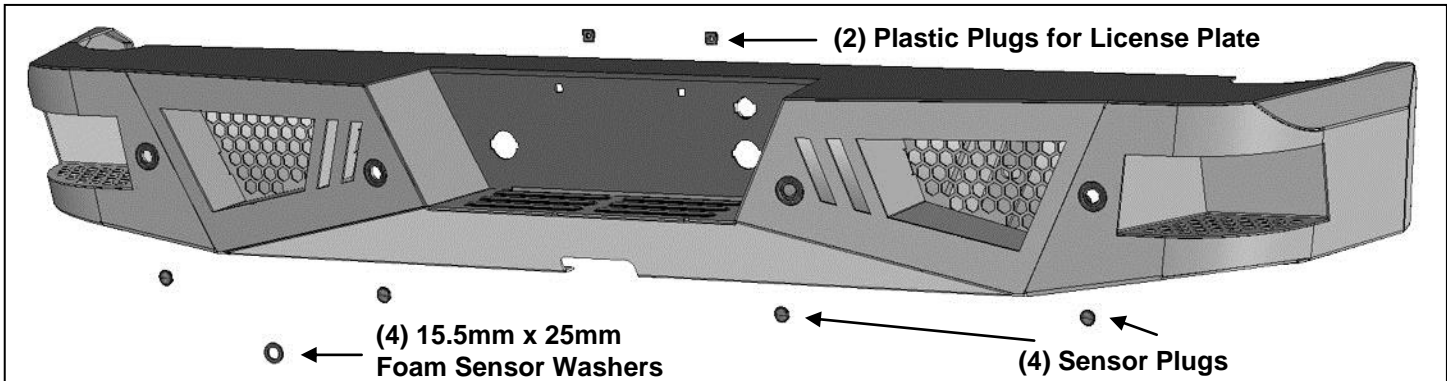

PROCEDURE:

REMOVE CONTENTS FROM BOX. VERIFY ALL PARTS ARE PRESENT. READ INSTRUCTIONS CAREFULLY BEFORE STARTING INSTALLATION. BUMPER IS HEAVY, ASSISTANCE IS RECOMMENDED TO AVOID POSSIBLE INJURY OR DAMAGE TO THE VEHICLE.

BUMPER IS DESIGNED TO INSTALL ON MODELS WITH FACTORY TOW HITCH ONLY.

1. Remove the license plate from the bumper. Next, unplug the wiring harnesses leading to the bumper. Move wiring harness away from bumper, **(Figure 1)**.
2. Place blocks or jack stands under the bumper to support it during mounting bolt removal. Once the bumper has been safely supported, remove the factory hardware attaching the bumper assembly, (with integrated receiver hitch if equipped), to the frame, **(Figure 1 & 2)**. **WARNING! Bumper with hitch is heavy**, assistance is required to hold the bumper in place during hardware removal to prevent bumper from falling.
3. Remove the receiver hitch, wiring harness, license plate lights, trailer plug and spare access lock from the factory bumper, **(Figure 3)**. Remove sensors, (if equipped), from bumper.
4. Determine correct procedure for your model.

Models without bumper sensors:

- a. From the front of the bumper, push the included Plugs into sensor mounts, **(Figure 4)**.

Models with bumper mounted sensors:

- a. Select (1) sensor. Remove the silicone seal from the end of the sensor, **(Figure 5)**.
 - b. Slide the included larger Sensor Seal over front of sensor, **(Figure 5)**.
 - c. Insert sensor with Seal into sensor mount in LD1 Bumper, **(Figure 6)**.
 - d. Secure each sensor to the socket with (2) 4mm Self Tapping Screws, **(Figure 6)**. **IMPORTANT:** Sensors fit snug in sockets. The 4mm Screws are used to apply slight pressure to lock the sensors in place. Tighten both screws evenly until they touch the sensor body only. Do not overtighten screws or damage to sensors will result.
5. **NOTE:** LD1 Bumper has mounting locations for auxiliary back up or flood light installation. If installing lights at this time, check for clearance around light. If additional clearance around light is required, remove the back screens from the light housings before the Bumper is installed, **(Figure 7)**.
 6. Install the license plate lights, towing plug, spare tire access lock and wiring harness from factory

- bumper into the LD1 Bumper.
7. Use a small flat blade screwdriver to pry the star washers off of the bolt plates used to attach the bumper to the frame brackets, **(Figure 8)**. Insert the bolt plates through the mounting tab on the back of the Bumper and receiver hitch if equipped, **(Figure 9)**. Reuse the star washers, if possible, to hold the bolt plates in the Bumper, **(Figure 10)**.
 8. With assistance, hold the LD1 Bumper assembly up to the ends of the frame. Temporarily support the weight of the Bumper. **WARNING:** To avoid possible injury or damage to the vehicle, do not proceed until the bumper is fully and safely supported.
 9. Reuse the factory hex nuts to attach the LD1 Bumper assembly with bolt plates to the frame, **(Figure 11)**. Snug but do not fully tighten hardware at this time.
 10. Level and adjust the Bumper and fully tighten all hardware.
 11. Plug the bumper wiring harness into the main harness. Use the included Wire Ties to secure the wiring harness to the bumper and frame as necessary.
 12. Do periodic inspections to the installation to make sure that all hardware is secure and tight.
 13. Use the included (2) push-in Plugs to attach the license plate to the Bumper, **(Figure 12)**.
 14. Do periodic inspections to the installation to make sure that all hardware is secure and tight.

To protect your investment, Do not use any type of polish or wax that may contain abrasives that could damage the finish. Mild soap may be used to clean the Bumper assembly.

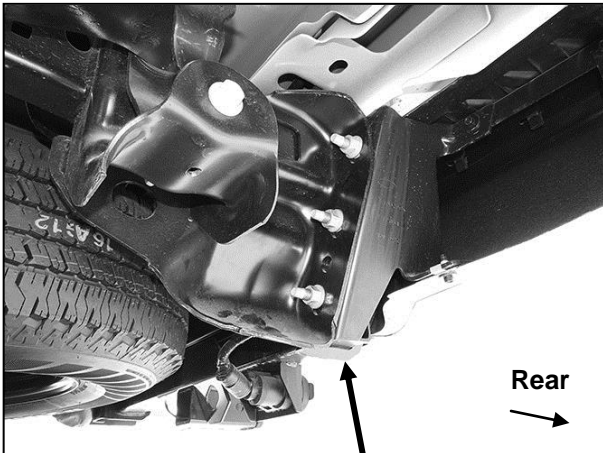

(Fig 1) Unplug wire harness leading to bumper. Remove hex nuts attaching bumper and receiver hitch if equipped, to frame and remove together

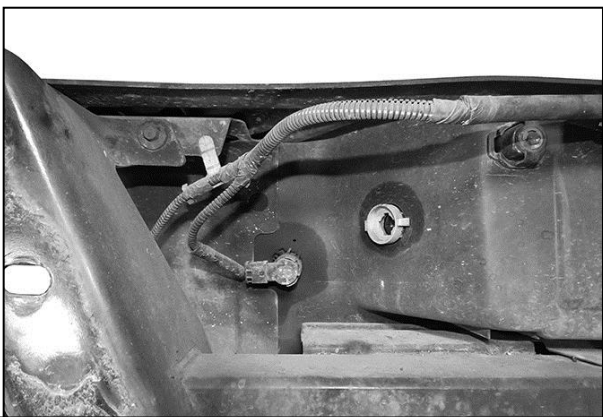

(Fig 3) Remove license lights, spare tire access lock, sensors and harness if equipped

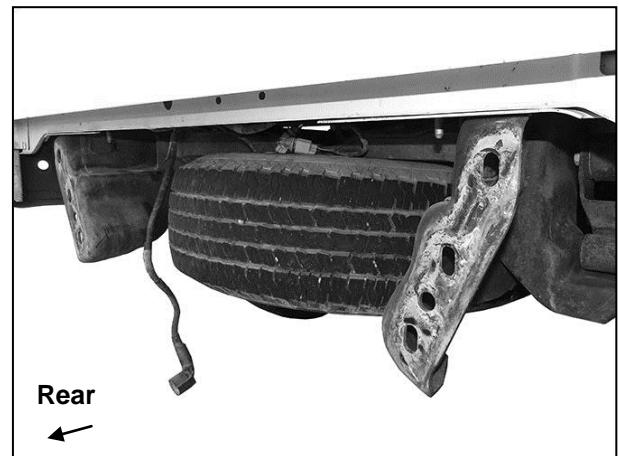

(Fig 2) Bumper removed

WARNING! Do not crawl under bumper unless it is properly supported on blocks or stands or the bumper may fall.

Passenger/right Side Installation Pictured

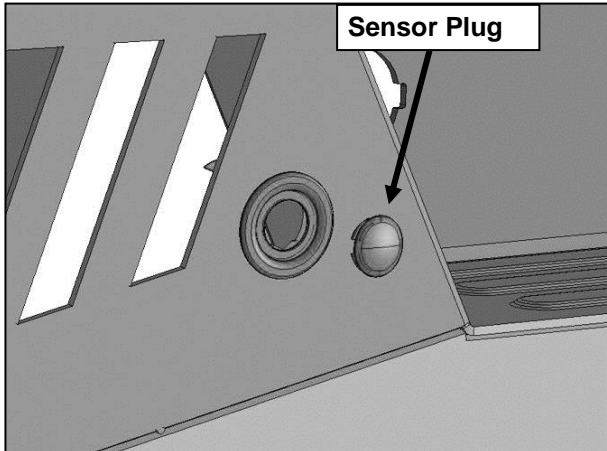

(Fig 4) Push sensor plug into mounting sleeve

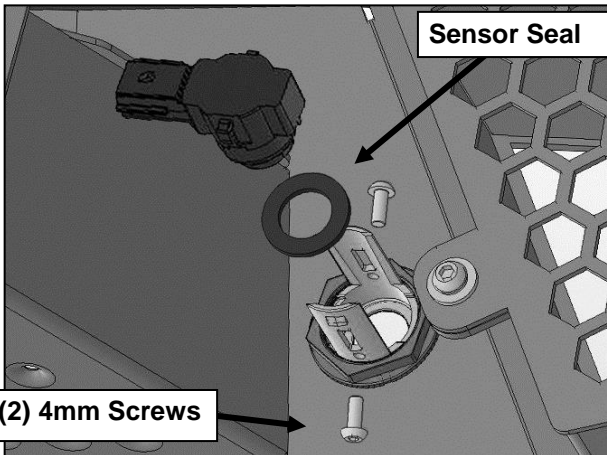

(Fig 6) Push sensor and seal into mounting sleeve. Use 4mm Screws to hold sensor in place

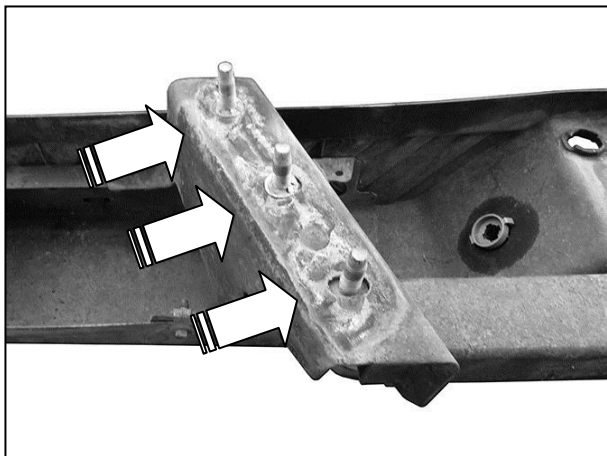

(Fig 8) Use flat blade screwdriver to carefully pry off star washers to remove bolt plates

IMPORTANT: Sensors fit snug in sockets. The 4mm Screws are only used to apply slight pressure to lock the sensors in place. Tighten both screws evenly until they touch the sensor body only. Do not overtighten screws or damage to sensors will result.

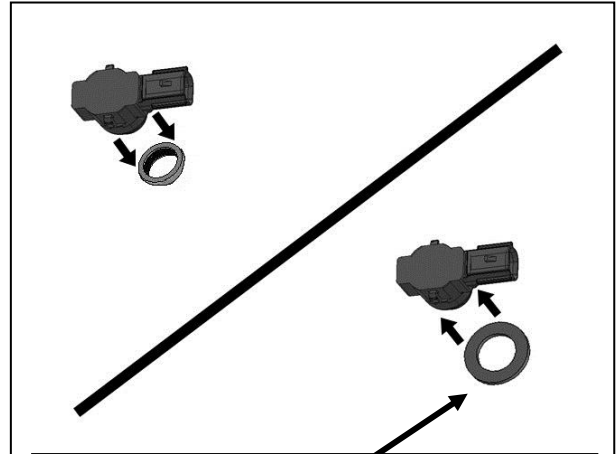

(Fig 5) Remove silicone seal from sensor. Slide large Seal over end of sensor (arrow)

Remove screens if necessary for additional clearance around or access to lights

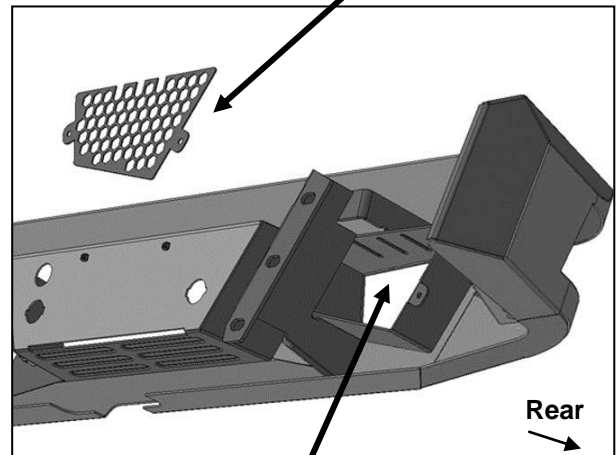

(Fig 7) Attach single light to center slot or use inner and outer slots for dual lights

Passenger/right Side Installation Pictured



(Fig 9) On models without receiver hitch, reuse triple bolt plate to attach bumper to end of frame



(Fig 11) Reuse factory hex nuts to attach Bumper and receiver hitch to frame



WARNING! Do not crawl under bumper unless it is properly supported on blocks or stands or the bumper may fall.

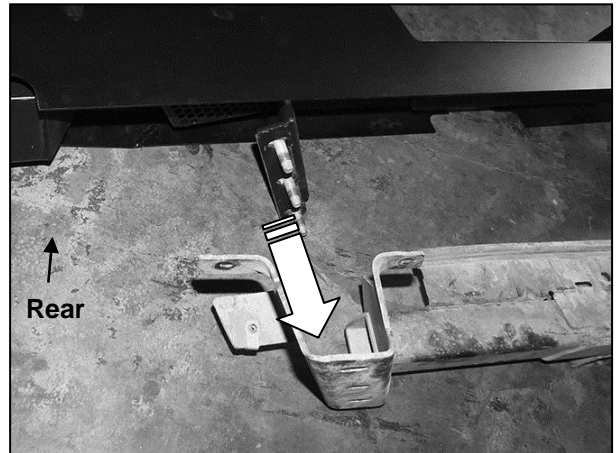

(Fig 10) On models with factory receiver hitch, slide LD1 Bumper up against the hitch. Insert triple bolt plates through bumper and hitch

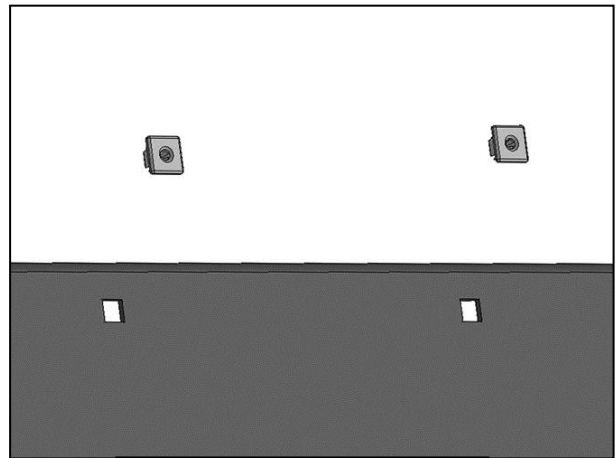

(Fig 12) Push plastic plugs into holes for license plate