



INSTALLATION INSTRUCTIONS

2017-2021 F250/350 SUPER DUTY AMBUSH XT FRONT BUMPER (NON-WINCH) PART #FD-20341

PARTS LIST:

1	Front Bumper Assembly	14	12mm x 32mm x 3mm Flat Washers
1	Center Mesh Fill Panel	14	12mm Lock Washers
1	Driver/left Mounting Bracket	6	12mm Hex Nuts
1	Passenger/right Mounting Bracket	4	8-1.25mm x 25mm Hex Bolts
1	Bumper Cover Plate	2	8-1.25mm x 16mm Hex Bolts
1	ACC Relocation Bracket	8	8mm x 24mm x 2mm Flat Washers
1	ACC 2019-Up Adapter Bracket	4	8mm Lock Washers
1	ACC Plastic Cover	4	8mm Hex Nuts
1	Driver/left LED Bracket	9	6mm x 25mm Button Head Bolts
1	Passenger/right LED Bracket	2	6mm x 20mm Button Head Combo Bolts
1	License Plate Bracket	17	6mm x 18mm x 1.6mm Flat Washers
2	Plastic Plugs for license plate mount	9	6mm Lock Washers
2	12mm Square Nut Plates	9	6mm Hex Nuts
6	12mm x 50mm Bolt Plates	2	6mm Flange Nuts
6	12mm Plastic Retainers	1	4mm Wrench
8	12-1.75mm x 50mm Hex Bolts		

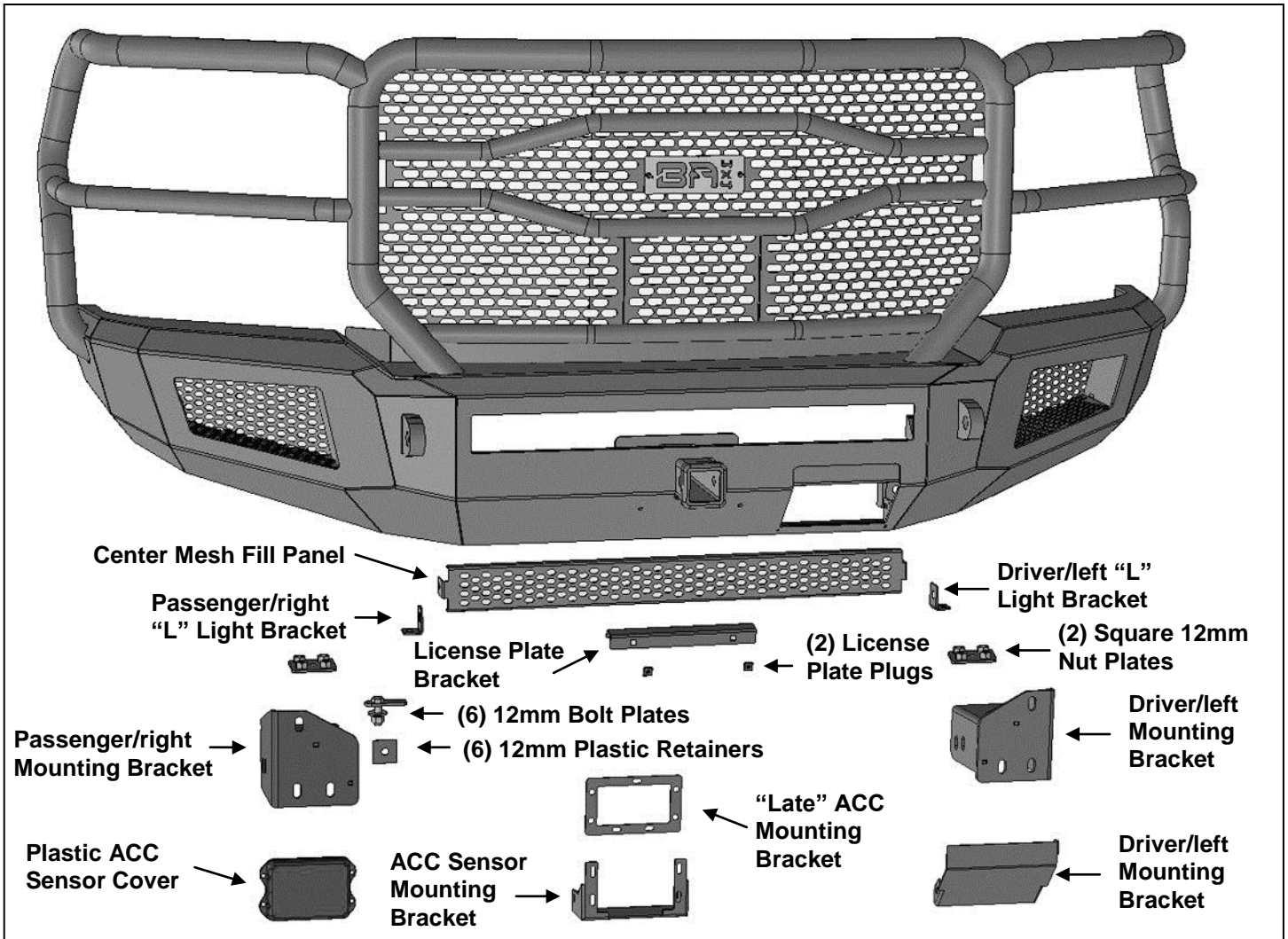

PROCEDURE:

REMOVE CONTENTS FROM BOX. VERIFY ALL PARTS ARE PRESENT. READ INSTRUCTIONS CAREFULLY BEFORE STARTING INSTALLATION. BUMPER IS HEAVY, ASSISTANCE IS HIGHLY RECOMMENDED TO AVOID POSSIBLE INJURY OR DAMAGE TO THE VEHICLE.

1. Remove the license plate and bracket. On models with factory fog lights, unplug the harness leading to the front bumper, **(Figure 1)**. Move harness away from bumper.
2. Remove the passenger/right bumper support attached to the frame bracket and outer end of the bumper, **(Figure 2)**. Repeat this **Step** to remove the driver/left side bumper support
3. Remove the plastic covers surrounding the tow hooks to uncover the bumper bolts, **(Figures 3 & 4)**.

Models with ACC sensor, (adaptive cruise control), attached to the driver/left side of the bumper. **(Figure 4)**.

- a. Remove cover from sensor. **(Figure 4)**.
- b. Carefully pry sensor off of mounting posts. **(Figure 5)**.
- c. Unplug and remove sensor.

4. Place blocks or jack stands under the front bumper to support it during mounting bolt removal. Once the bumper has been safely supported, remove the factory bumper bolts, **(Figure 6)**. **WARNING!** Assistance is required to hold the bumper in place during bolt removal to prevent the bumper from falling. Carefully slide the bumper off over the tow hooks, **(Figure 7)**.
5. Remove the passenger/right side tow hook from the end of the frame, **(Figures 7)**. Next, remove the (4) factory hex nuts, lower frame extension if equipped and double bolt plates from the end of the frame, **(Figure 7)**. Repeat this **Step** to remove the driver/left side tow hook and lower frame extension.
6. Select the passenger/right Frame Mounting Bracket, **(Figure 8)**. Slide the Bracket over the end of the frame. Select (1) 12mm Square Nut Plate. Place the Nut Plate over the top of the Bracket. Insert (4) 12mm x 50mm Hex Bolts, (4) 12mm Lock Washers and (4) 12mm Flat Washers up through the frame, the Bracket and into the Nut Plate, **(Figure 8)**. Do not tighten hardware at this time.
7. Reuse the factory (2) double bolt plates and hex nuts from **Step 5** to attach the sides of the Mounting Bracket to the sides of the frame, **(Figures 8 & 9)**. Snug but do not fully tighten hardware at this time.
8. Repeat **Steps 6 & 7** to attach the driver/left Frame Bracket.
9. Carefully unwrap the Ambush Bumper. Determine if center LED bar style light or the included Fill Panel will be installed.

Mesh Fill Panel installation (do not install Fill Panel with light).

- a. Select the passenger/right “L” Bracket, **(Figure 10)**. Attach the Bracket to the mounting tab on the back of the Bumper with the included (1) 8mm x 25mm Hex Bolt, (2) 8mm Flat Washers, (1) 8mm Lock Washer and (1) 8mm Hex Nut. Repeat to install the driver/left “L” Bracket.
- b. Attach the Center Fill Panel to the “L” Brackets with the included (2) 8mm x 25mm Hex Bolts, (4) 8mm Lock Washers, (2) 8mm Flat Washers and (2) 8mm Hex Nuts, **(Figure 11)**. Do not fully tighten hardware at this time. Adjust position and tighten hardware.

Center LED light installation (sold separately). **NOTE:** It may be easier to attach the light before Bumper Assembly is attached to the Brackets.

- a. Select passenger/right “L” Bracket, **(Figures 10)**. **NOTE:** “L” Brackets are offset and can be switched side to side as required to fit most lights. Attach the Bracket to the passenger/right mounting tab on the back of the Bumper with the included (1) 8mm x 25mm Hex Bolt, (2) 8mm Flat Washers, (1) 8mm Lock Washer and (1) 8mm Hex Nut. Repeat to install the driver/left “L” Bracket.
- b. Attach the LED light assembly to the “L” Brackets with the included (2) 8mm x 16mm Hex Bolts, (2) 8mm Lock Washers and (2) 8mm Flat Washers, **(Figure 12)**. Do not fully tighten hardware at this time. Adjust light position and tighten hardware.
- c. Follow light manufacturer’s instructions to wire the light to the vehicle’s electrical system once Bumper has been fully installed.

LED light installation at ends of bumper (sold separately).

- a. Insert light into opening and up to mounting slots on the passenger/right side of the Bumper. Check for clearance between front and back of light. If necessary, remove the screens from the back of the openings, **(Figure 13)**.
 - b. Follow the light manufacturer’s instructions to attach each light to slot in the top of the light opening, **(Figure 13)**. **NOTE:** On two light systems, attach the flood light to the outer slot and the spot light to the inner slot.
 - c. Repeat the above **Steps** for driver/left side light installation.
 - d. Follow light manufacturer’s instructions to properly wire the light to the vehicle electrical system.
10. Determine if the vehicle is equipped with ACC sensor.

Models without sensor

- a. Select the Bumper Cover Plate, **(Figure 14)**.
- b. Attach the Cover Plate to the tabs on the back of the Bumper with the included (3) 6mm x 25mm Button Head Bolts, (6) 6mm Flat Washers, (3) 6mm Lock Washers and (3) 6mm Hex Nuts, **(Figure 15)**.
- c. Push Cover up tight to Bumper and fully tighten hardware.

Models with ACC sensor, remove wiring harness from factory bumper, (Figure 16):

Vehicles with early style ACC with tabs on ends:

- a. Select the Sensor Mounting Bracket and Plastic Cover, **(Figure 17)**.
- b. Attach the ACC sensor to the **back** of the Mounting Bracket and the Cover to the front of the Bracket with the included (3) 6mm x 25mm Button Head Bolts, (6) 6mm Flat Washers, (3) 6mm Lock Washers and (3) 6mm Hex Nuts, **(Figure 17)**. **IMPORTANT:** Do not overtighten 6mm hardware or damage to the sensor could result.

Vehicles with late style ACC with tabs on top and bottom:

- a. Select the Adapter Bracket, **(Figure 18)**.
- b. Attach the ACC sensor to the **back** of the Adapter with the included (3) 6mm x 25mm Button Head Bolts, (6) 6mm Flat Washers, (3) 6mm Lock Washers and (3) 6mm Hex Nuts, **(Figure 18)**.
- c. Select the Plastic Cover.
- d. Attach the ACC sensor and Adapter to the **back** of the Mounting Bracket and the Cover to the front with the included (3) 6mm x 25mm Button Head Bolts, (6) 6mm Flat Washers, (3) 6mm Lock Washers and (3) 6mm Hex Nuts, **(Figure 19)**.

Attach sensor and Bracket Assembly to back of Bumper.

- a. Line up the ACC sensor and Bracket assembly with the bottom tabs on the back of the Bumper.
 - b. Attach the ACC sensor and Bracket assembly to the tabs with the included (2) 6mm x 25mm Button Head Bolts, (4) 6mm Flat Washers, (2) 6mm Lock Washers and (2) 6mm Hex Nuts, **(Figure 20)**.
 - c. With the sensor at vertical, fully tighten hardware. **NOTE:** Minor adjustment, (tilt sensor slightly forward or back), may be required after test driving.
- 11.** Select (3) 12mm Bolt Plates and (3) 12mm Plastic Retainers, **(Figure 21)**. Insert the Bolt Plates up and into the mounting plate on the back of the passenger/right side of the Bumper. Thread the Plastic Retainers onto the Bolt Plates to hold them in position on the Bumper, **(Figures 21 & 22)**. Repeat this **Step** to install the (3) 12mm Bolt Plates on the driver/left side of the Bumper. **NOTE:** Plastic Retainers are provided to help hold the Bolt Plates in during Bumper installation. Use is not mandatory for installation.
- 12.** With assistance, carefully position the Bumper Assembly up to the Bumper Brackets. Temporarily support the weight of the Bumper. **WARNING:** To avoid possible injury or damage to the vehicle, do not proceed until the bumper is fully and safely supported.
- 13.** Attach the passenger/right side of the Bumper to the Mounting Bracket with the included (3) 12mm Flat Washers, (3) 12mm Lock Washers and (3) 12mm Hex Nuts, **(Figures 23 & 24)**. Repeat this **Step** to attach the driver/left side of the Bumper. Do not fully tighten hardware at this time.
- 14.** Level and adjust the Bumper and fully tighten all hardware.
- 15.** If front license plate is required, attach the License Plate Bracket to the holes in the bumper with the included (2) 6mm x 20mm Button Head Combo Bolts and (2) 6mm Flange Nuts, **(Figure 25)**.
- 16.** Models with front license plate, insert (2) Plastic Plugs into the Bumper, **(Figure 26)**. Reuse factory hardware to attach license plate to Plugs.
- 17.** On models with grille mounted factory camera, remove the center screen, **(Figure 26)**.
- 18.** Do periodic inspections to the installation to make sure that all hardware is secure and tight.

To protect your investment, do not use any type of polish or wax that may contain abrasives that could damage the finish. Mild soap may be used to clean the Front Bumper assembly.

Passenger/right Side Installation Pictured

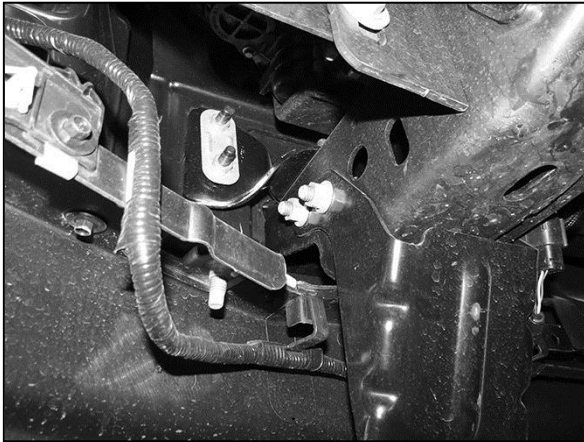

(Fig 1) Unplug wire harness leading to bumper (pictured from behind bumper)

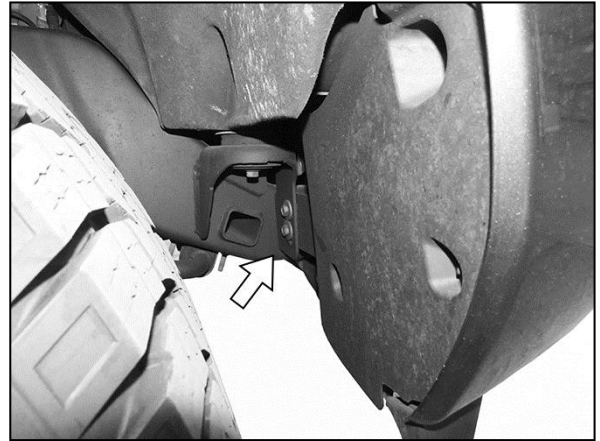

(Fig 2) Remove outer bumper to frame supports from both ends of bumper (arrow)



(Fig 3) Remove plastic cover surrounding tow hook (passenger/right side pictured-arrow)

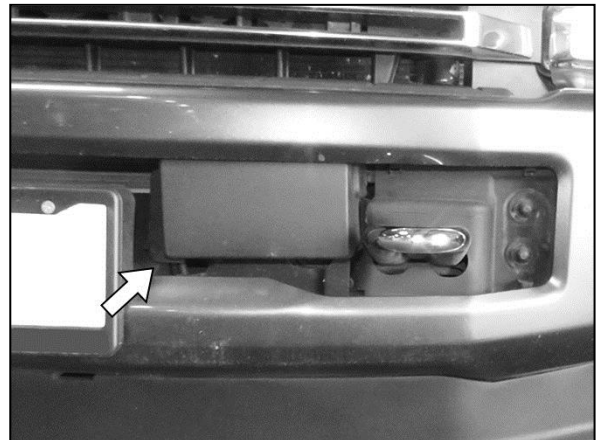

(Fig 4) Models with ACC sensor (adaptive cruise control), remove plastic cover from sensor (driver/left side pictured-arrow)

Passenger/right Side Installation Pictured

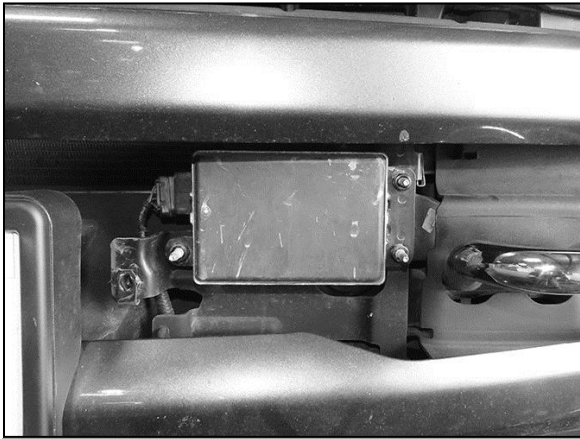

(Fig 5) Unplug and carefully pry sensor off of mounting posts to remove sensor



(Fig 6) Remove bumper bolts (driver side pictured)

WARNING! Do not remove bumper bolts unless it is properly supported on blocks or stands or the bumper may fall.

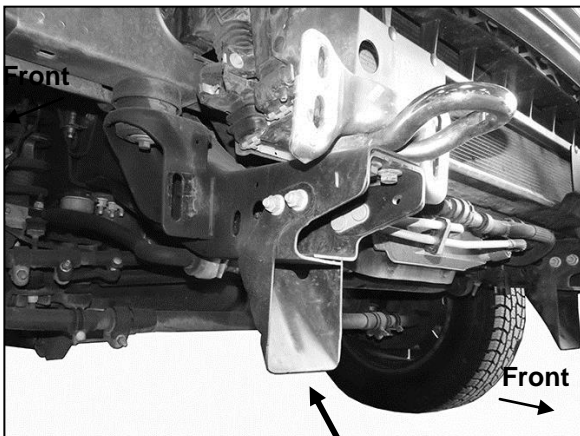

(Fig 7) Remove tow hook assembly and lower frame extensions from bottom of frame

Reuse the factory double bolt plates and hardware to attach Mounting Bracket to sides of frame

Square 12mm Nut Plate

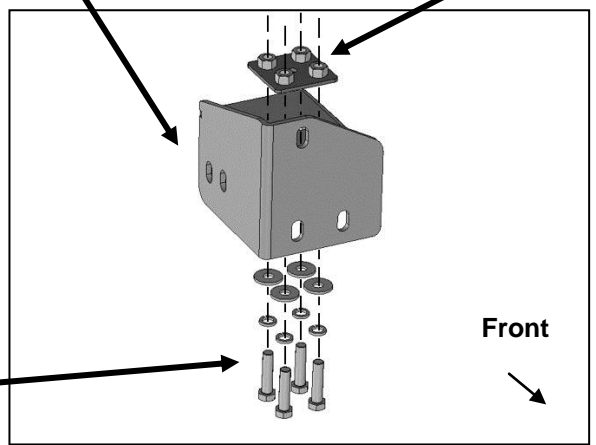

- (4) 12mm x 50mm Hex Bolts
- (4) 12mm Lock Washers
- (4) 12mm Flat Washers

(Fig 8) Attach Mounting Brackets to frame (passenger/right Bracket illustrated)

Passenger/right Side Installation Pictured

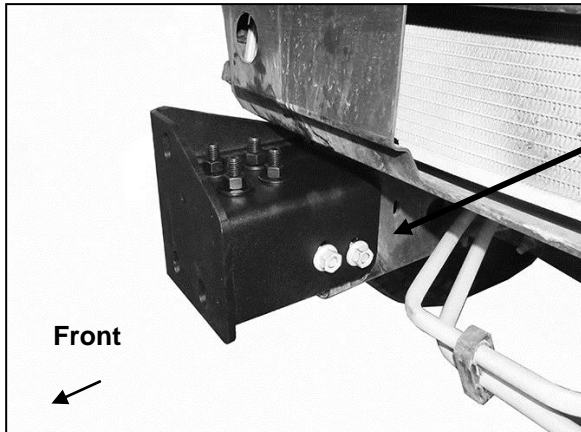

Reuse the factory double bolt plates and hardware to attach Mounting Bracket to sides of frame

8mm x 25mm Hex Bolt
(2) 8mm Flat Washers
8mm Lock Washer
8mm Hex Nut

(Fig 9) Attach Mounting Brackets to frame (passenger/right Bracket pictured)

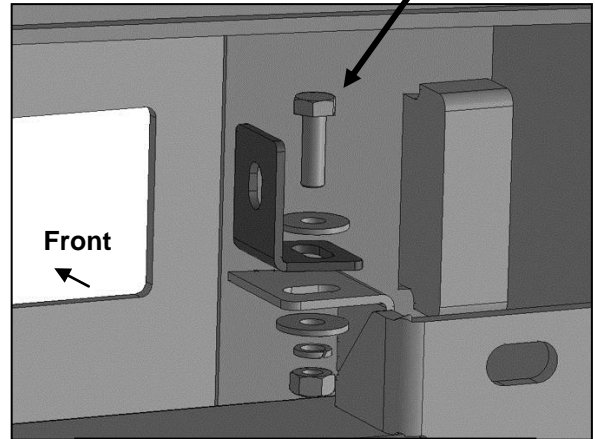

(Fig 10) Attach "L" Brackets to mounting tabs on back of Bumper

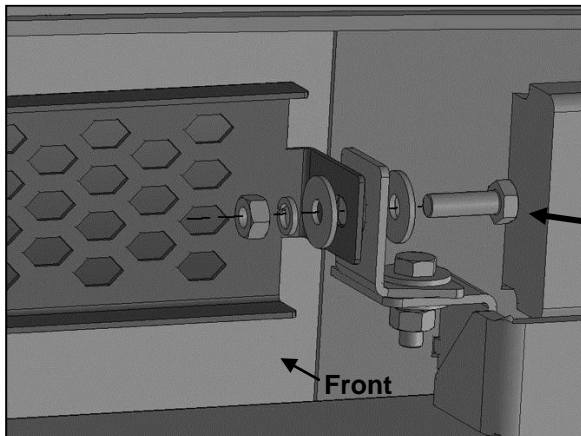

(Fig 11) Attach Mesh Fill Panel to "L" Brackets

8mm x 25mm Hex Bolt
(2) 8mm Flat Washers
8mm Lock Washer
8mm Hex Nut

8mm x 16mm Hex Bolt
8mm Lock Washer
8mm Flat Washer

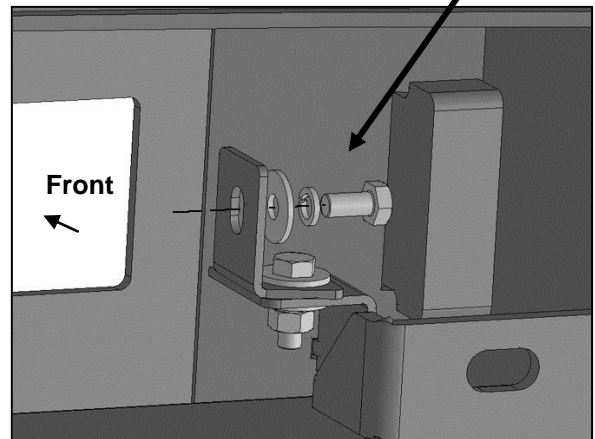

(Fig 12) Attach LED bar style light to "L" Brackets (passenger/right side illustrated)

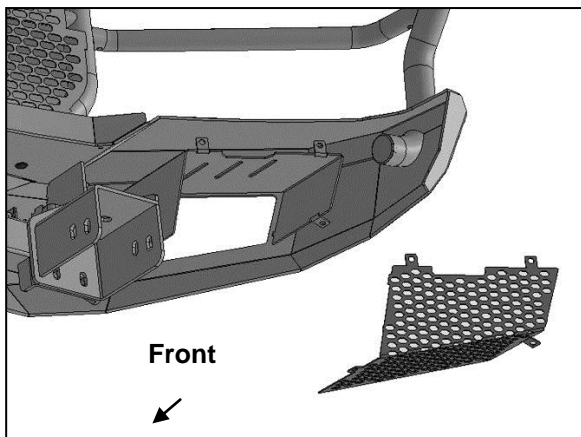

(Fig 13) Check for clearance around lights (not included). Remove screens for additional access or to clear lights as needed

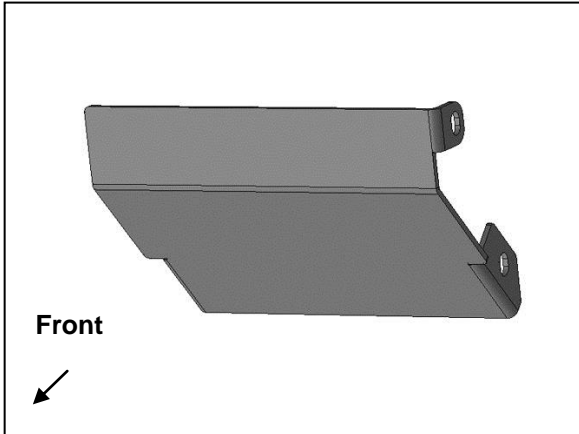

(Fig 14) Models without ACC sensor, attach Cover Plate to tabs on back of Bumper

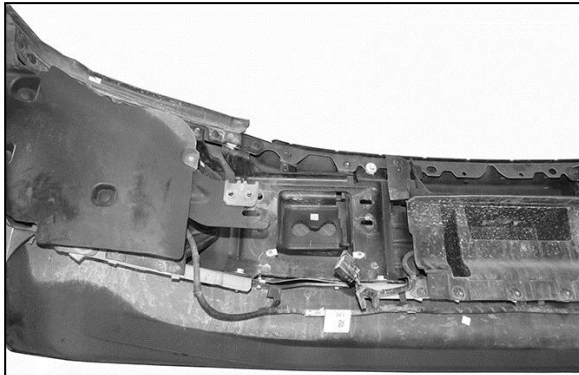

(Fig 16) Remove wiring harness for ACC sensor from factory bumper

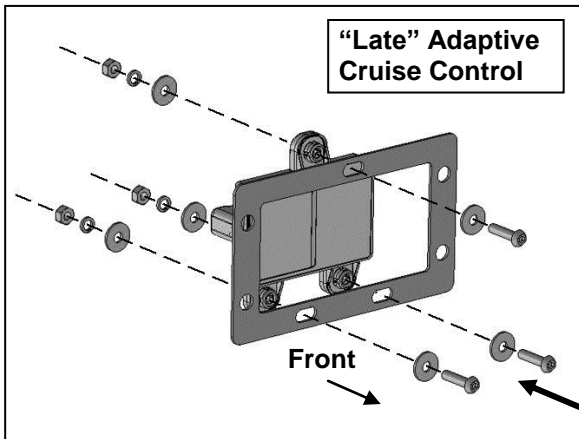

(Fig 18) Attach "Late" ACC sensor to back of Adapter Bracket

- (3) 6mm x 25mm Button Head Screws
- (6) 6mm Flat Washers
- (3) 6mm Lock Washers
- (3) 6mm Hex Nuts

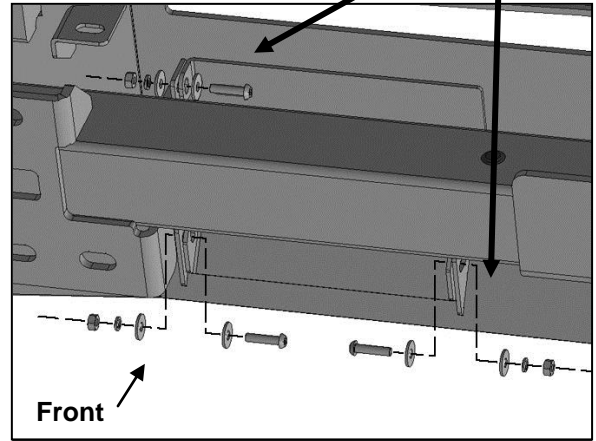

(Fig 15) Models without ACC sensor, attach Cover Plate to tabs on back of Bumper

- (3) 6mm x 25mm Button Head Bolts
- (3) 6mm Flat Washers
- (3) 6mm Lock Washers
- (3) 6mm Hex Nuts

"Early" Adaptive Cruise Control

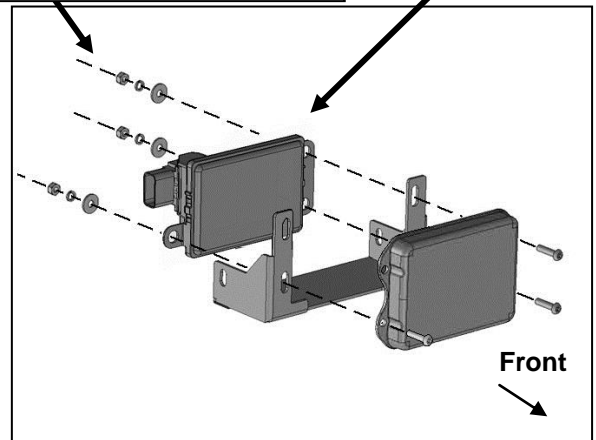

(Fig 17) Attach "Early" ACC sensor to back of Mounting Bracket and Plastic Cover to front of Bracket

- (3) 6mm x 25mm Button Head Bolts
- (3) 6mm Flat Washers
- (3) 6mm Lock Washers
- (3) 6mm Hex Nuts

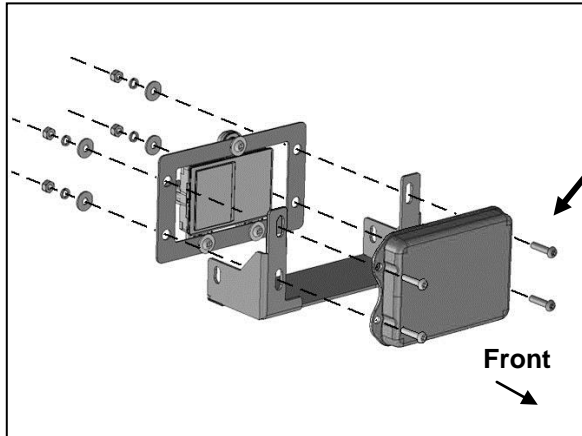

- (4) 6mm x 25mm Button Head Bolts
- (8) 6mm Flat Washers
- (4) 6mm Lock Washers
- (4) 6mm Hex Nuts

(Fig 19) Attach Adapter Bracket with “Late” ACC sensor to back of Mounting Bracket, and attach Plastic Cover to front

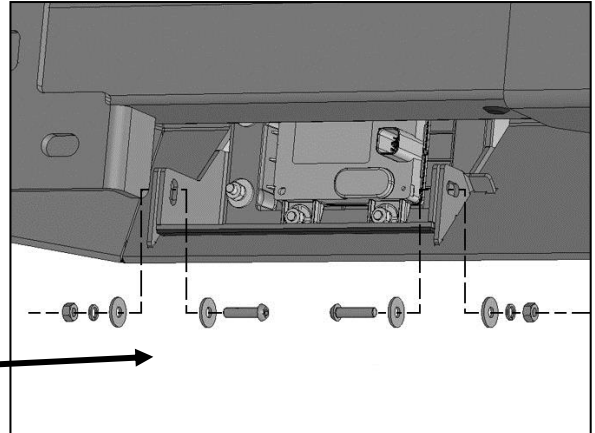

(Fig 20) Attach sensor assembly (early or late) to tabs on back of Bumper

- (2) 6mm x 25mm Button Head Bolts
- (4) 6mm Flat Washers
- (2) 6mm Lock Washers
- (2) 6mm Hex Nuts

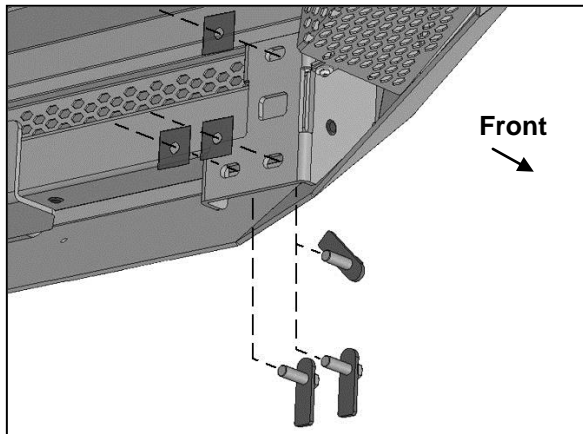

(Fig 21) Insert (3) 12mm Bolt Plates through mounting plate on back of Bumper. Thread the 12mm Plastic Retainers onto Bolt Plates (passenger/right side illustrated)

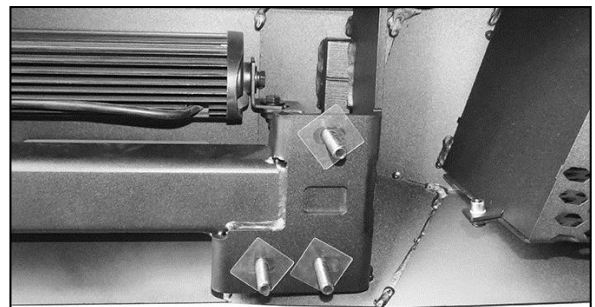

(Fig 22) Thread the 12mm Plastic Retainers onto Bolt Plates to hold Bolt Plates in position (passenger/right side illustrated)

Passenger/right Side Installation Pictured

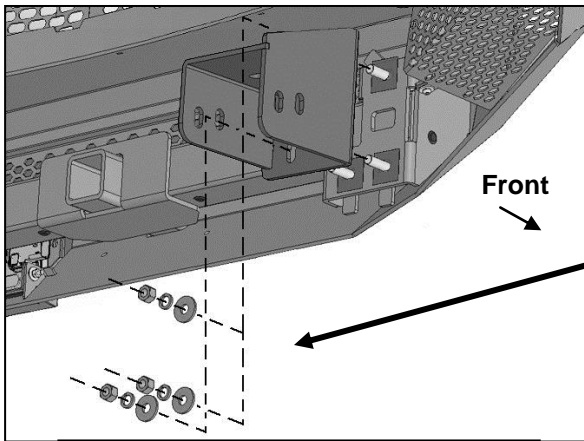

(Fig 23) Attach passenger/right side of Bumper to Bumper Bracket

WARNING! Do not crawl under bumper unless it is properly supported on blocks or stands or the bumper may fall.

- (3) 12mm Flat Washers
- (3) 12mm Lock Washers
- (3) 12mm Hex Nuts

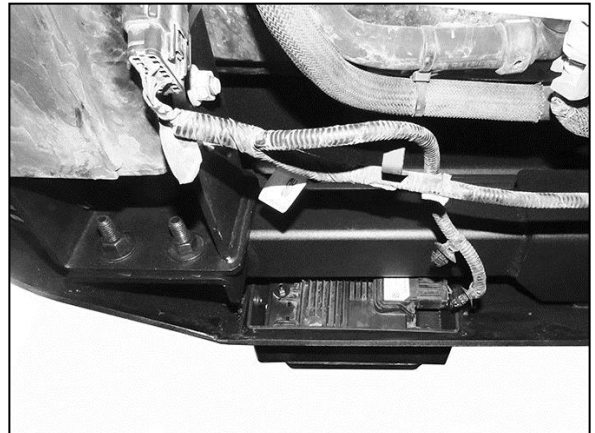

(Fig 24) Driver/left side of Bumper attached to Bumper Bracket. Sensor installation also pictured

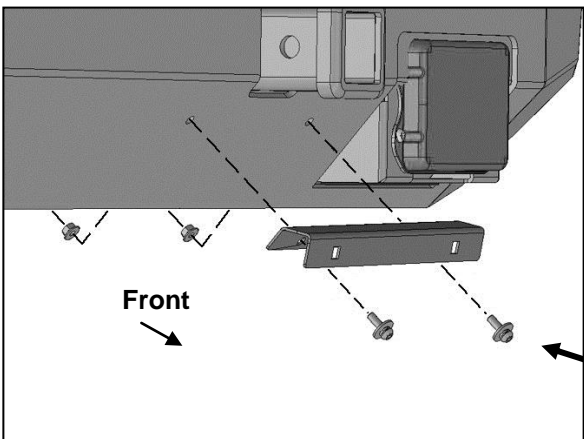

(Fig 25) Attach License Plate Bracket to Bumper

- (2) 6mm x 20mm Button Head Combo Bolts
- (2) 6mm Flange Nuts



Complete Installation

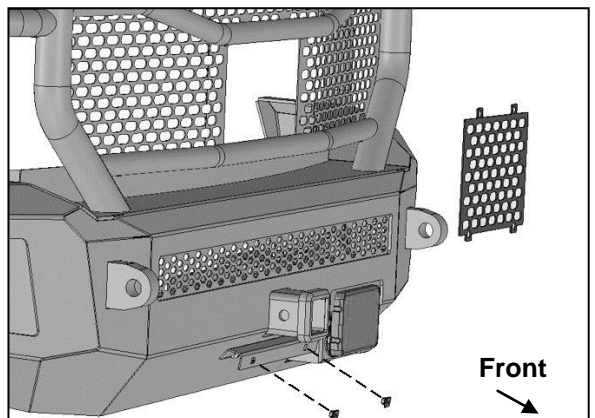

(Fig 26) Remove center screen if equipped with grille mounted camera. Push Plastic Plugs into holes in Bumper for license plate