



INSTALLATION INSTRUCTIONS



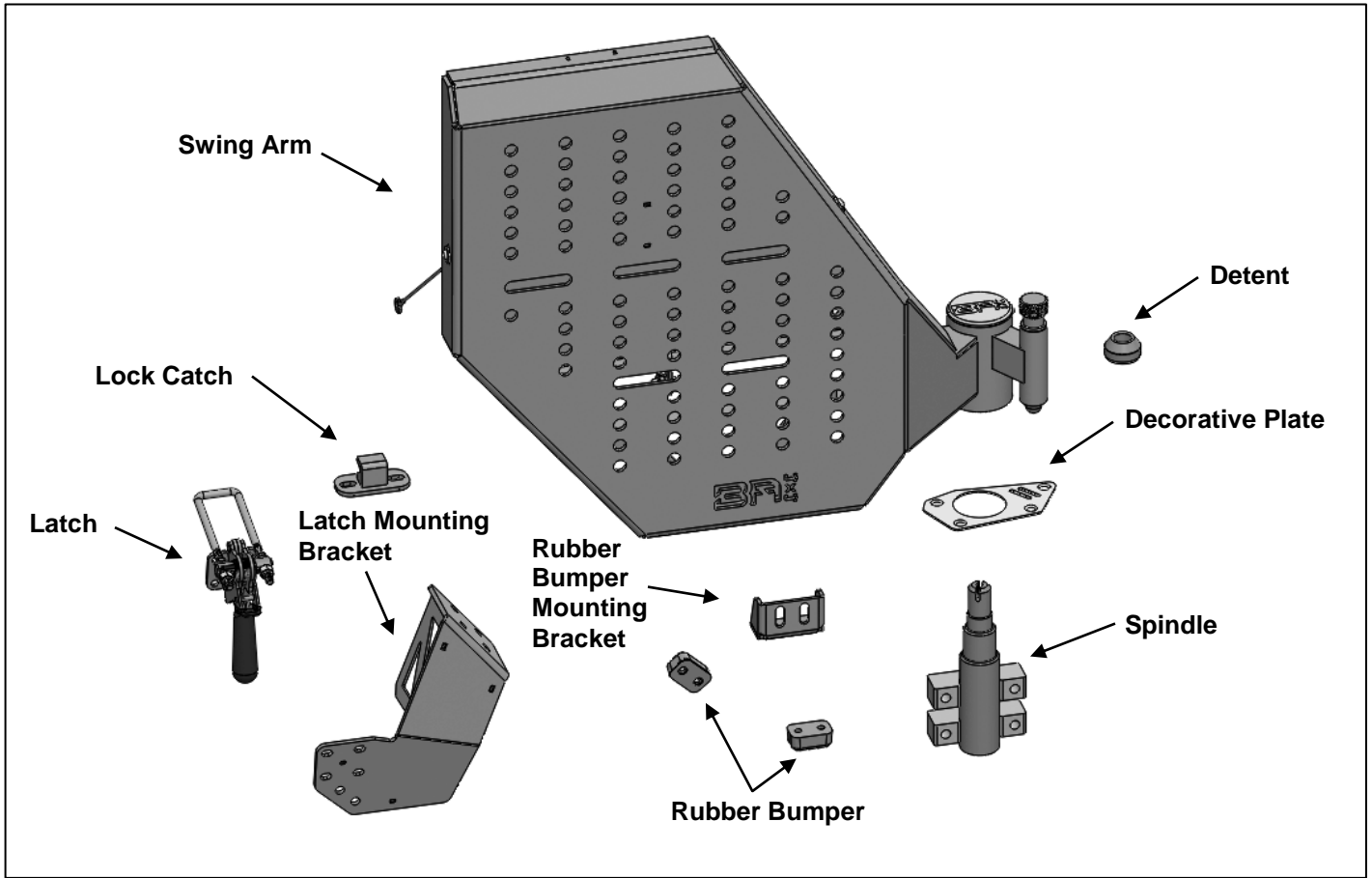

2010-2024 TOYOTA 4RUNNER PRO SERIES PASSENGER SIDE SWINGOUT PART #TR-2965PS

PARTS LIST:

| Qty | Item Description | Qty | Item Description |
|-----|--|-----|---------------------------------|
| 1 | Passenger/Right Swing Arm | 2 | 0.3m Rubber Trim |
| 1 | Spindle | 1 | S=4 Wrench |
| 1 | Decorative Plate | 1 | S=5 Wrench |
| 1 | Small NSK Bearing | 1 | M4_15 Phillips Screw |
| 1 | Large NSK Bearing | 8 | 6mmx12mmx1.6mm Flat Washer |
| 1 | Oil Seal (I.D 45mm,O.D 65mm,Height 12mm) | 4 | M6_20 Button Head Bolt |
| 1 | Bearing Retainer (O.D 45mm) | 4 | 6mm Nylon Lock Nut |
| 1 | Spindle Shim (4X4mm) | 15 | 8mm x 16mm x 1.6mm Flat Washer |
| 1 | Spindle Cap | 5 | 8mm x 22mm x 2mm Flat Washer |
| 1 | Detent | 6 | 8mm Lock Washer |
| 1 | 1mm Pin Spacer | 6 | M8_20 Button Head Bolt |
| 1 | 2mm Pin Spacer | 5 | M8_25 Button Head Bolt |
| 2 | Rubber Bumper | 1 | M8_8 Screw |
| 1 | 1mm Rubber Bumper Shim | 7 | 8mm Nylon Lock Nut |
| 1 | 2mm Rubber Bumper Shim | 4 | 8 1.25mm x 25mm Hex Bolt |
| 1 | Latch Bracket | 4 | 12mm Lock Washer |
| 1 | Latch | 4 | 12mm x 24mm x 2.5mm Flat Washer |
| 1 | Rubber Bumper Mounting Bracket | 4 | 12-1.75mm x 40mm Hex Bolt |
| 1 | Lock Catch | 1 | M24 Castle Nut |



TOOLS REQUIRED

| | | | |
|--|--|--|---|
|  <p>Ratchet</p> |  <p>Sockets</p> |  <p>Extensions</p> |  <p>Wrench</p> |
|--|--|--|---|

PRODUCT CARE AND MAINTENANCE

- Textured coat finished should be cleaned ONLY with a mild soap on a damp sponge.
- BA recommends wiping down the product with a light coat of lubricate (i.e. WD40) periodically to maintain its luster.
- DO NOT apply polish or wax that requires buffing for removal as this may damage the finish.
- DO NOT coat the product with any type of shine such as Tire Shine or glossy aerosol or gel. This can cause discoloration, staining or bubbling.

- 1** Follow (Fig 1 – 8) to replace Decorative Plate, then install Spindle and Stiffening Bracket to Bumper. Then, attach Detent and Swing Arm. Ensure all fasteners are hand tightened.



(Fig 1) Remove Plate from Bumper

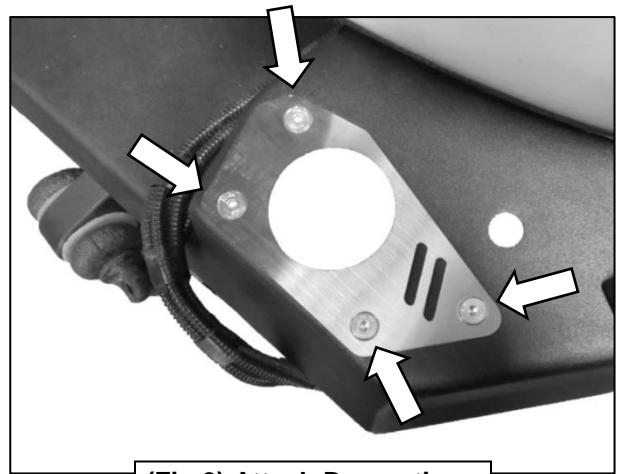

(Fig 2) Attach Decorative Plate by reusing hardware

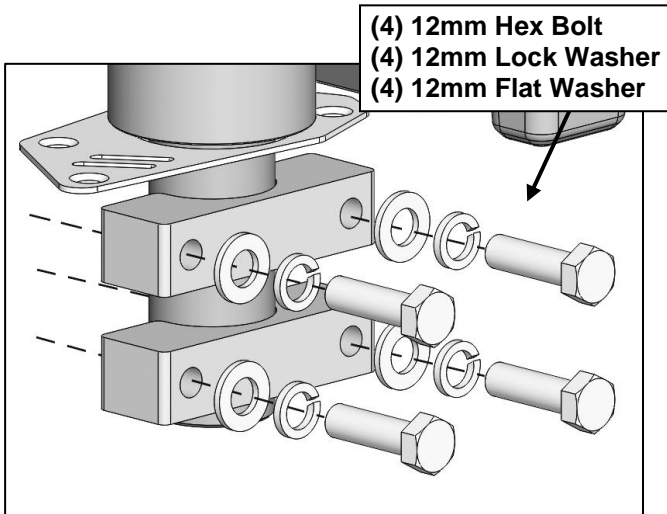

(Fig 3) Attach Spindle to Bumper

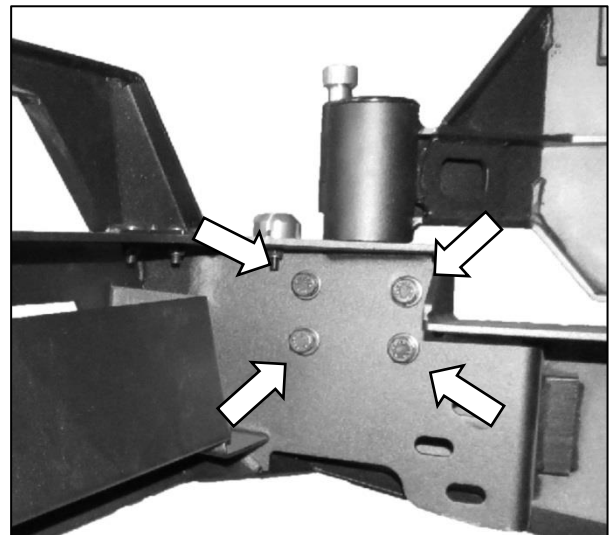

(Fig 4) Attached Spindle

- (1) 8x25mm Button Head Bolt
- (1) 8x16mm Flat Washer
- (1) Detent

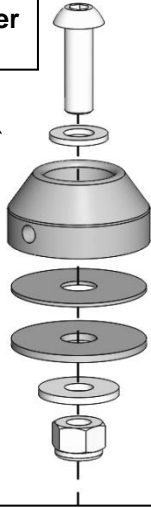

- (1) 1mm Pin Spacer
- (1) 2mm Pin Spacer
- (1) 8x22mm Flat Washer
- (1) 8mm Lock Nut

(Fig 5) Attach Detent to Bumper



(Fig 6) Attached Detent

- (1) 4x15mm Phillips Screw

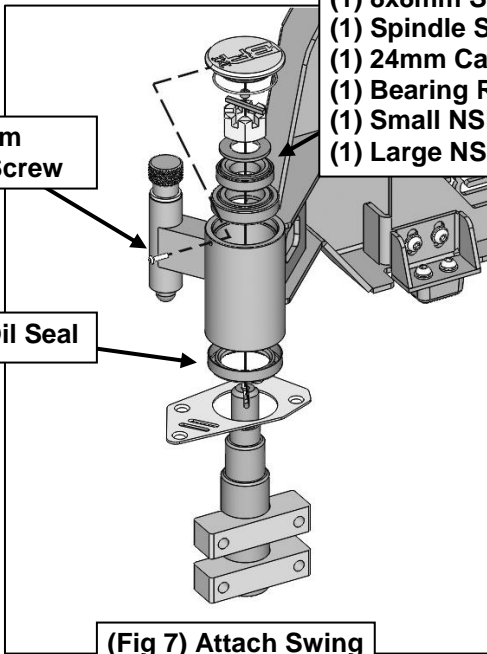

- (1) Spindle Cap
- (1) 8x8mm Screw
- (1) Spindle Shim
- (1) 24mm Castle Nut
- (1) Bearing Retainer
- (1) Small NSK Bearing
- (1) Large NSK Bearing

- (1) Oil Seal

(Fig 7) Attach Swing Arm to Spindle

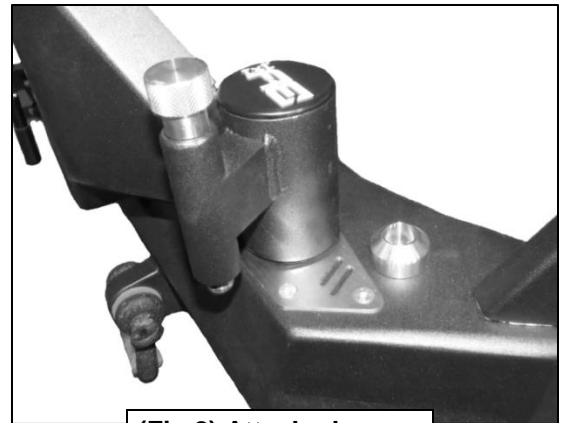

(Fig 8) Attached Detent and Swing Arm

2 Follow (Fig 9 – 14) to attach Rubber Bumper Mounting Bracket and Rubber Bumpers, as well as Latch Mounting Bracket. Ensure all fasteners are hand tightened.

- (2) 8x20mm Button Head Bolt
- (2) 8mm Lock Washer
- (2) 8x16mm Flat Washer

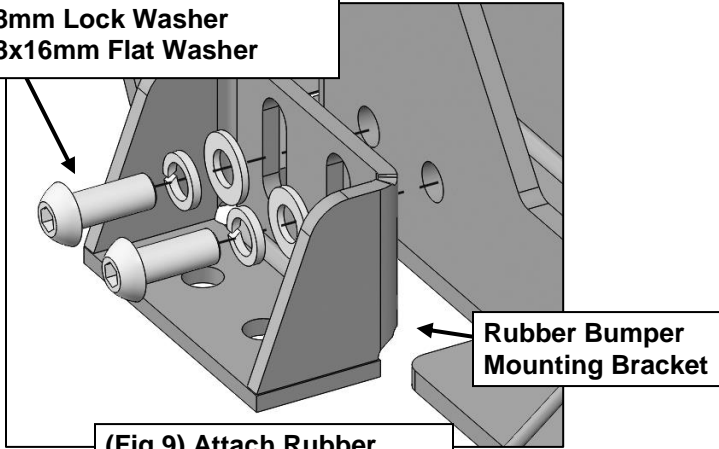

(Fig 9) Attach Rubber Bumper Mounting Bracket

- (2) 8x20mm Button Head Bolt
- (2) 8mm Lock Washer
- (2) 8x16mm Flat Washer

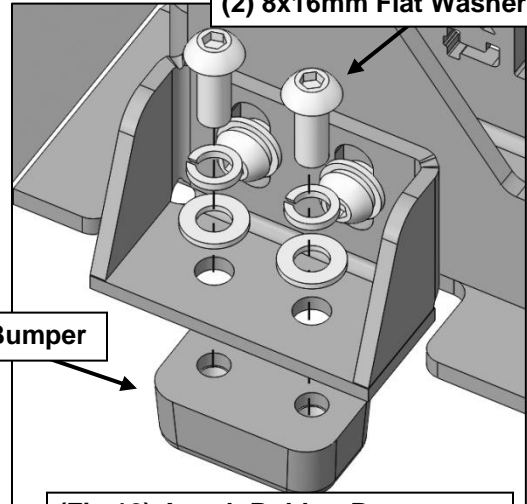

Rubber Bumper

(Fig 10) Attach Rubber Bumper to Rubber Bumper Mounting Bracket

- (2) 0.3m Rubber Trim

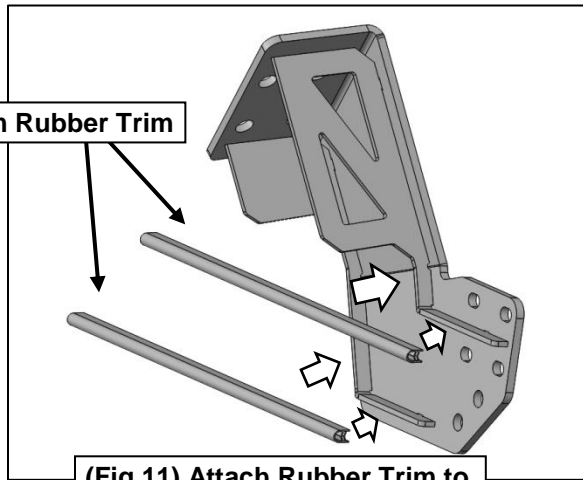

(Fig 11) Attach Rubber Trim to Latch Mounting Bracket

- (4) 8x25mm Hex Bolt
- (8) 8x16mm Flat Washer
- (4) 8mm Lock Nut

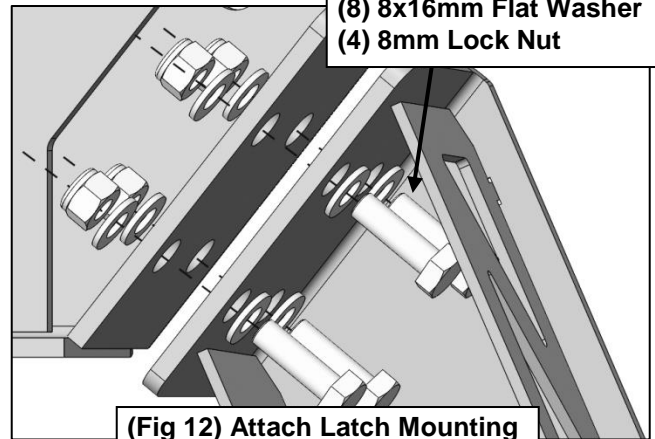

(Fig 12) Attach Latch Mounting Bracket to Swing Arm

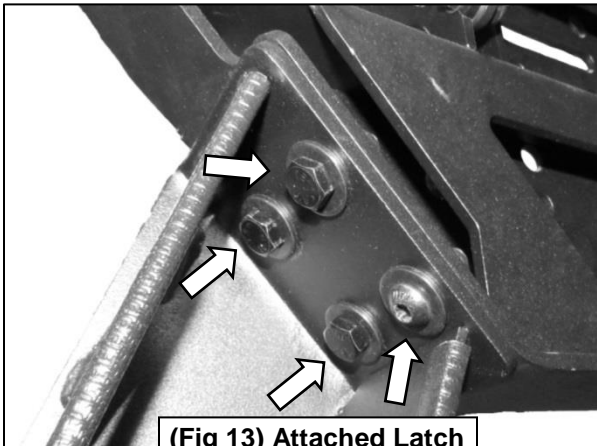

(Fig 13) Attached Latch Mounting Bracket

- (2) 8x20mm Button Head Bolt
- (2) 8mm Lock Washer
- (2) 8x16mm Flat Washer
- (1) 2mm Rubber Bumper Shim
- (1) 1mm Rubber Bumper Shim

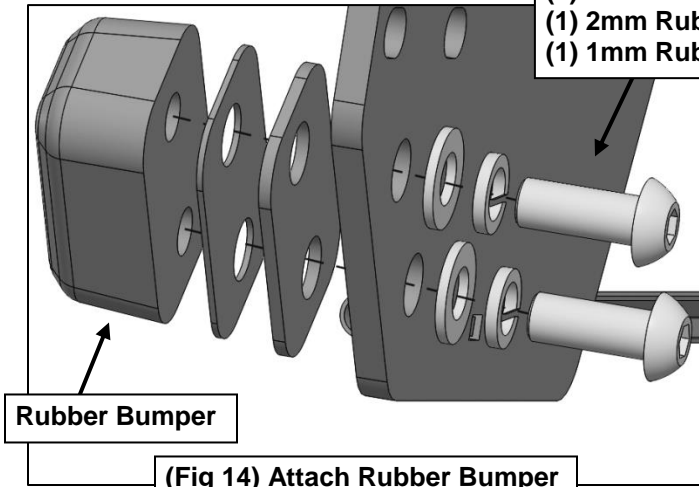

Rubber Bumper

(Fig 14) Attach Rubber Bumper to Latch Mounting Bracket

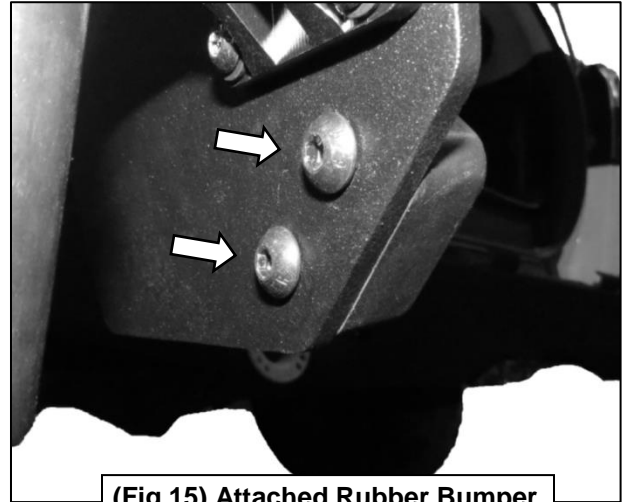

(Fig 15) Attached Rubber Bumper

3

Follow (Fig 16 – 20) to attach Latch and Lock Catch to Swing Arm and Bumper. Ensure all fasteners are hand tightened.

- (2) 6x20mm Button Head Bolt
- (4) 6x12mm Flat Washer
- (2) 6mm Lock Nut

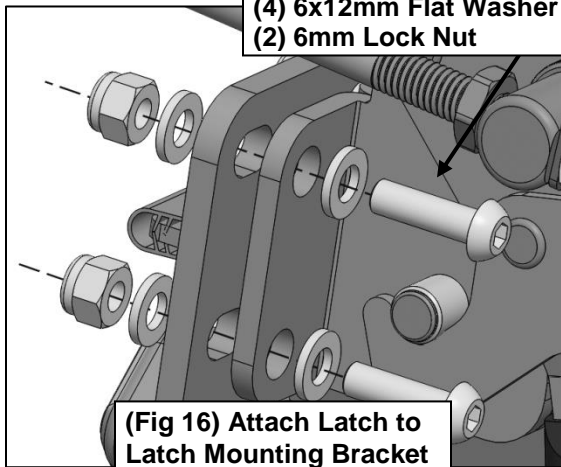

(Fig 16) Attach Latch to Latch Mounting Bracket

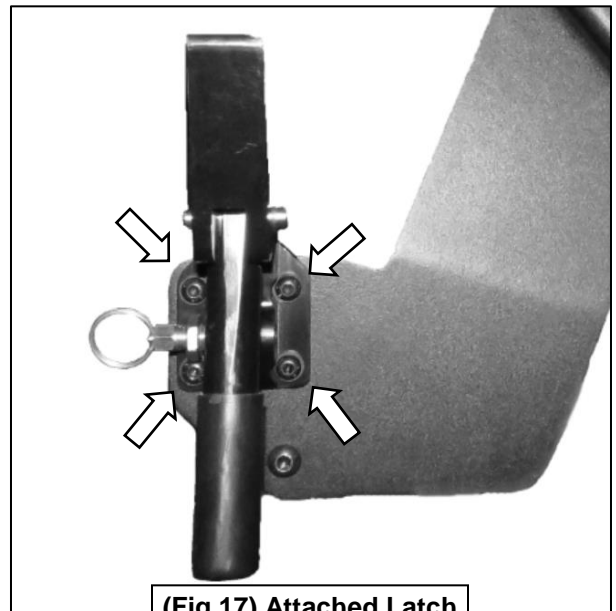

(Fig 17) Attached Latch

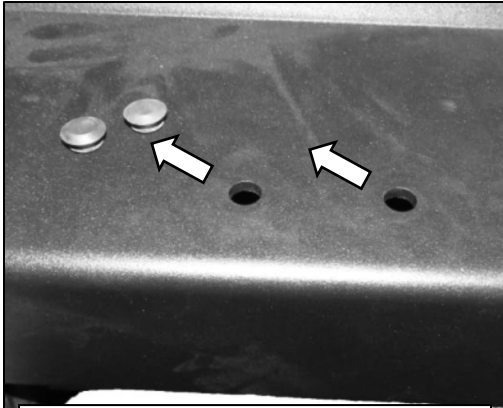

(Fig 18) Remove Plugs in Lock Catch installation point on Bumper

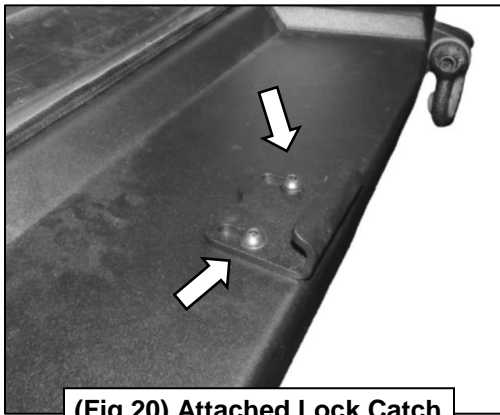

(Fig 20) Attached Lock Catch

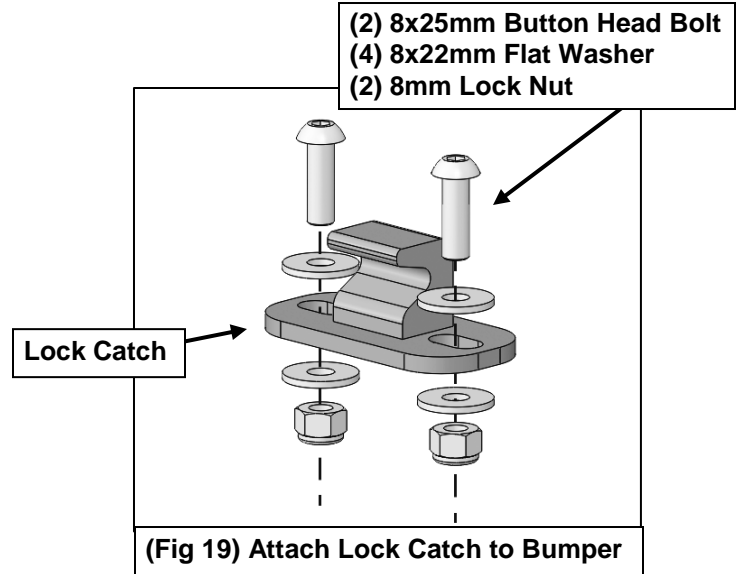

4

At this point, ensure Swing Arm is level, then tighten all fasteners. Installation is complete. Do periodic inspections to the installation to make sure that all hardware is secure and tight.

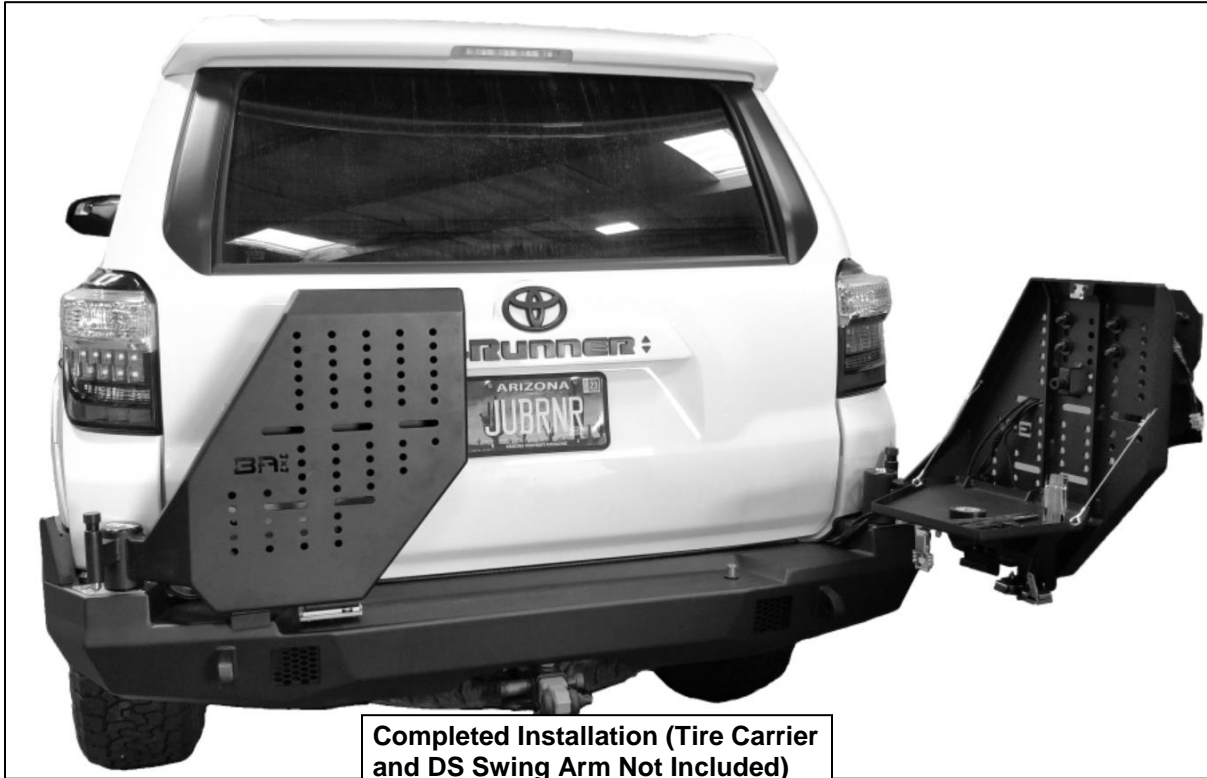

Completed Installation (Tire Carrier
and DS Swing Arm Not Included)