

2014-2021 TOYOTA TUNDRA ECO SERIES FRONT WINCH BUMPER PART #TN-19336

PARTS LIST:

1	HD Front bumper	6	10mm x 30mm x 2.5mm Flat Washers
1	Winch Tray/Bracket Assembly	6	10mm Lock Washers
1	LH Lower Support Bracket	6	10mm Hex Nuts
1	RH Lower Support Bracket	2	8-1.25mm x 16mm Hex Bolts
1	License Plate Bracket	2	8-1.25mm x 25mm Hex Bolts
2	Plastic Plugs for License Plate	2	8mm Hex Nut
2	Rubber Sensor Hole Block Offs	4	8mm Lock Washer
10	Nylon Cable Ties 200mm	6	8mm x 24mm x 2mm Flat Washers
1	"L" Light bracket driver side	2	6mm x 20mm Button Head Screw
1	"L" Light bracket passenger side	2	6mm Nylon Lock Nuts
2	D-Rings	4	6mm x 12mm x 1.2mm Flat Washers
4	12-1.75mm x 35mm Hex Bolts	1	6mm Allen Wrench
4	12mm x 37mm OD x 3mm Flat Washers	4	4mm x 10mm Button Head Screws
4	12mm Lock Washers	1	4mm Allen Wrench

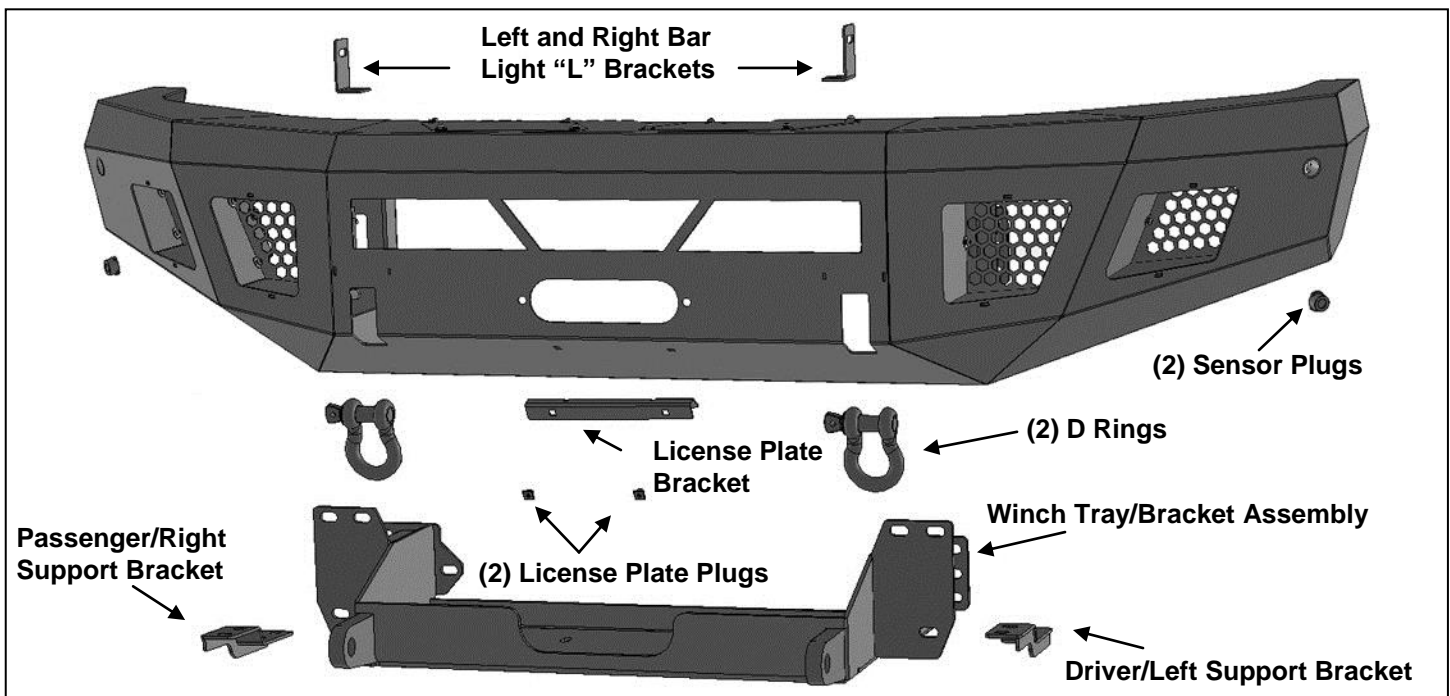

PROCEDURE:

REMOVE CONTENTS FROM BOX. VERIFY ALL PARTS ARE PRESENT. READ INSTRUCTIONS CAREFULLY BEFORE STARTING INSTALLATION. BUMPER IS HEAVY, ASSISTANCE IS HIGHLY RECOMMENDED TO AVOID POSSIBLE INJURY OR DAMAGE TO THE VEHICLE.

INSTALLATION IS NOT COMPATIBLE WITH LASER CONTROLLED CRUISE CONTROL SYSTEMS.

1. Open the hood and remove the plastic cover on top of the radiator and the grille, (Figure 1).
Temporarily remove the plastic grille.

2. Move to the passenger/right wheel opening. Remove the hardware attaching the plastic cover to the back and bottom of the outer end of the front bumper, **(Figures 2 & 3)**. Next, remove the plastic clip attaching the cover to the side of the frame and remove the cover, **(Figure 4)**.
3. Remove the hardware attaching the plastic body fill panel between the bumper and the headlight and temporarily remove the body panel, **(Figures 2, 5 & 6)**.
4. Repeat **Steps 2 and 3** to remove the plastic covers from the driver/left side of the vehicle.
5. On models with factory fog lights, unplug both lights, **(Figure 7)**. On models with bumper mounted sensors, unplug all sensors. Release the wiring harnesses from the clips attached to the back of the bumper and move all wiring harnesses away from the bumper.
6. Remove the license plate and bracket.
7. Remove the hardware attaching the plastic cover on the bottom of the bumper to the bottom of the frame cross member, **(Figure 8)**. Next, remove both tow hooks. **NOTE:** Tow hooks will not be reinstalled.
8. Place blocks or jack stands under the front bumper to support it during mounting bolt removal. Once the bumper has been supported, remove the hex nuts attaching the inner bumper bracket to the end of the frame, **(Figures 9)**. **WARNING!** Assistance is required to hold the bumper in place during hardware removal to prevent the bumper from falling. Remove the bumper assembly, **(Figure 10)**.
9. Next, select passenger/right Support Bracket, **(Figure 11)**. Reuse the tow hook hardware to attach the Support Bracket to the bottom of the frame, **(Figures 11 & 12)**. Snug but do not fully tighten hardware. Repeat this Step to attach the driver/left Support Bracket.
10. Select the Winch Plate/Bracket assembly, **(Figure 13)**. Carefully place the assembly on top of the Support Brackets and up to the ends of the frame. Reuse the (8) factory bumper bracket hex nuts to attach the Winch Tray assembly to the ends of the frame, **(Figures 13 & 14)**. Snug but do not fully tighten hardware at this time.
11. Line up the holes in the Support Brackets with the holes in the bottom of the Winch Tray assembly. Attach the Support Brackets to the bottom of the Winch Tray with (4) 12mm x 35mm Hex Bolts, (4) 12mm Lock Washers and (4) 12mm Flat Washers, **(Figures 13 & 14)**. Snug but do not fully tighten hardware at this time.
12. If installing winch, (not included), attach the winch to the Winch Tray at this time. Winch must be installed before Bumper is placed in position against Brackets. **NOTE:** It also may be easier to attach winch cable guide to Bumper assembly at this time. Follow manufacturer's instructions to properly attach the winch to the vehicle's electrical system.
13. **Optional Center LED light installation**, (sold separately). **NOTE:** Light must be installed in Bumper before Bumper Assembly is attached to the Winch Tray and Brackets. **IMPORTANT:** Clearance between the bar style LED light and the winch and/or winch tray must be determined before installing Bumper assembly.
 - a. Select the L/R "L" Brackets, **(Figure 15)**. **NOTE:** "L" Brackets are offset for universal fitment for most LED bar style lights. Attach the LED light assembly to the "L" Brackets with the included (2) 8mm x 16mm Hex Bolts, (2) 8mm Lock Washers and (2) 8mm Flat Washers, **(Figure 15)**. Do not fully tighten hardware at this time. **NOTE:** "L" Brackets may require modification for hardware larger than 8mm or use brackets supplied with light if possible.
 - b. Attach the light and brackets to the top of the (2) tabs on the back of the Bumper with the included 8mm x 25mm Hex Bolts, (4) 8mm Flat Washers, (2) 8mm Lock Washers and (2) 8mm Hex Nuts, **(Figure 15)**. Adjust light position and tighten hardware.
 - c. Follow light manufacturer's instructions to wire the light to the vehicle's electrical system once Bumper has been fully installed.
14. **LED light installation at ends of bumper** (sold separately).
 - a. Insert light into opening and up to mounting slots. Check for clearance between front and back of light. If necessary, remove the screens from the back of the openings, **(Figure 16)**. **NOTE:** Screens must be removed before Bumper is installed.



INSTALLATION INSTRUCTIONS

- b. Follow the light manufacturer's instructions to attach each light to slot in the top of the light opening. **NOTE:** On two light systems, attach the flood light to the outer slot and the spot light to the inner slot.
 - c. Repeat the above steps for passenger side light installation.
 - d. Follow light manufacturer's instructions to adjust and properly wire the light to the vehicle electrical system.
15. If front license plate is required, attach the License Plate Bracket to the holes in the bumper with the included (2) 6mm x 20mm Button Head Screws, (4) 6mm Flat Washers and (2) 6mm Nylon Lock Nuts, **(Figure 17)**. Insert (2) Plastic Plugs into the square holes in the Bracket. Reuse the factory screws to attach the license plate to the plastic plugs.
16. **NOTE:** It may also be easier to install sensors, (if equipped), before installing the Bumper.

Models without bumper sensors:

- a. Select the included (2) Rubber Plugs.
- b. From behind bumper, push plugs into sensor mounting holes, **(Figure 18)**.

Models with bumper mounted sensors:

- a. Push the sensor into the mounting socket in the back of the bumper.
 - b. Secure each sensor to the socket with (2) 4mm x 10mm Button Head Screws, **(Figure 18)**. **IMPORTANT:** Sensors fit snug in sockets. The 4mm Screws are used to apply slight pressure to lock the sensors in place. Tighten both screws evenly until they touch the sensor body only. Do not overtighten screws or damage to sensors will result.
17. With assistance, position the Bumper Assembly up to the mounting plate on the Winch Tray. Temporarily support the weight of the Bumper. **WARNING:** To avoid possible injury or damage to the vehicle, do not proceed until the Bumper is fully and safely supported.
18. Line up the (3) studs in the passenger/right side mounting plate on the inside of the Bumper with the (3) slots in the Winch Tray Bracket Assembly. Attach the Bumper to the Bracket with the included (3) 10mm Flat Washers, (3) 10mm Lock Washers and (3) 10mm Hex Nuts, **(Figures 19 & 20)**. Do not fully tighten hardware at this time. Repeat this Step to attach the driver/left side mounting plate to the Frame Bracket.
19. Level and adjust the bumper and fully tighten all hardware. **NOTE:** It may be necessary to temporarily remove the outer bumper assembly to shift the inner Winch Tray/Bracket assembly left or right for more adjustment. Once properly adjusted, fully tighten the Winch Tray/Bracket assembly hardware first, then reinstall the outer Bumper assembly and fully tighten the Bumper mounting hardware.
20. Reinstall the plastic fill panels between the bumper and the headlights, **(Figure 5)**. Reinstall the plastic grille and top cover, **(Figure 1)**.
21. Do periodic inspections to the installation to make sure that all hardware is secure and tight.

To protect your investment, wax this product after installing. Regular waxing is recommended to add a protective layer over the finish. Do not use any type of polish or wax that may contain abrasives that could damage the finish. Mild soap may be used to clean the HD Front Bumper assembly.

Passenger/right Side Installation Pictured



(Fig 1) Remove plastic cover and grille

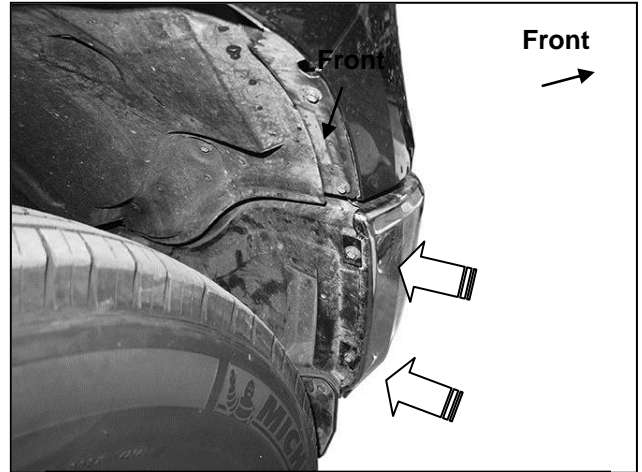

(Fig 2) Remove hardware attaching plastic cover to back of bumper (arrows)

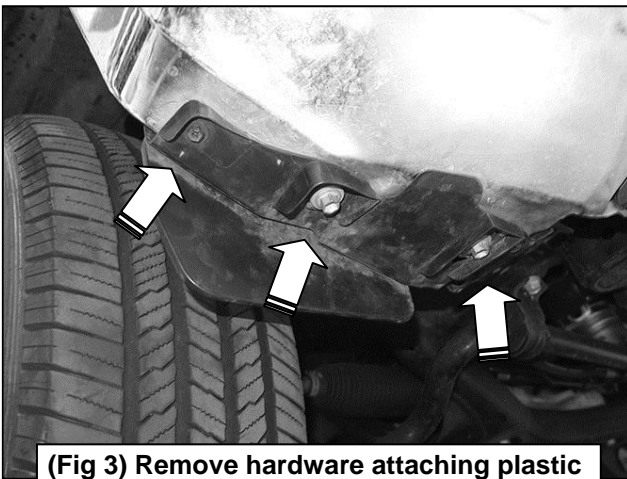

(Fig 3) Remove hardware attaching plastic cover to bottom of bumper (arrows)

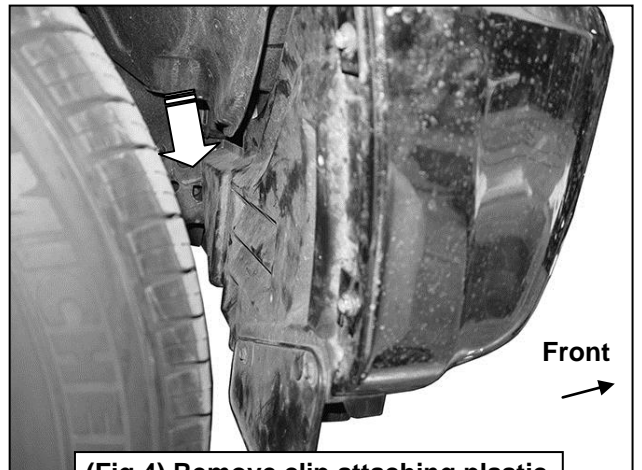

(Fig 4) Remove clip attaching plastic cover to side of frame (arrow)



(Fig 5) Remove plastic fascia body fill panel between headlight and bumper (arrow)



(Fig 6) Plastic cover and fascia body panel removed

WARNING! Do not remove bumper bolts unless the bumper is properly supported on blocks or stands or the bumper may fall.

Remove both tow hooks

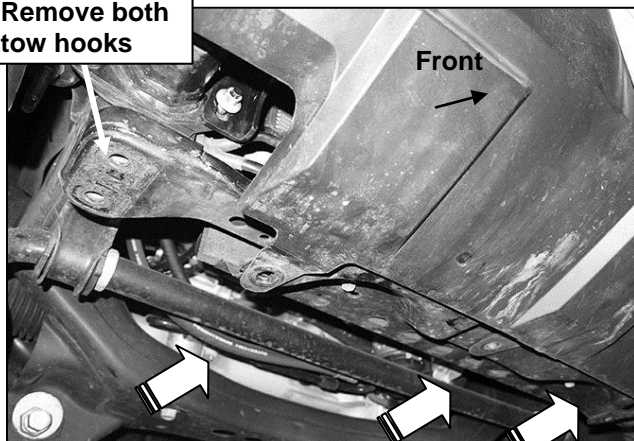

(Fig 8) Remove hardware attaching plastic cover on bottom of bumper to cross member (arrows)

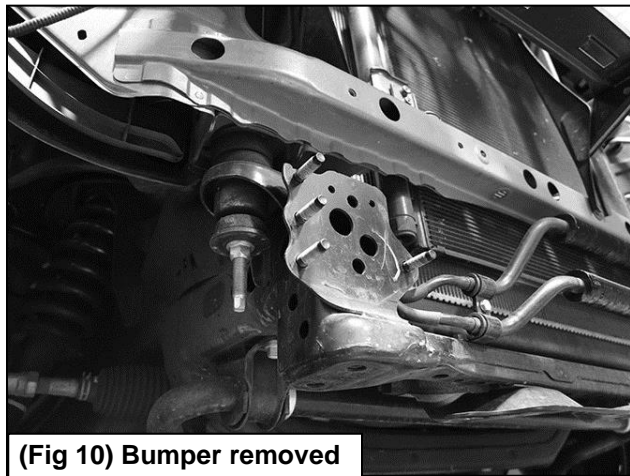

(Fig 10) Bumper removed

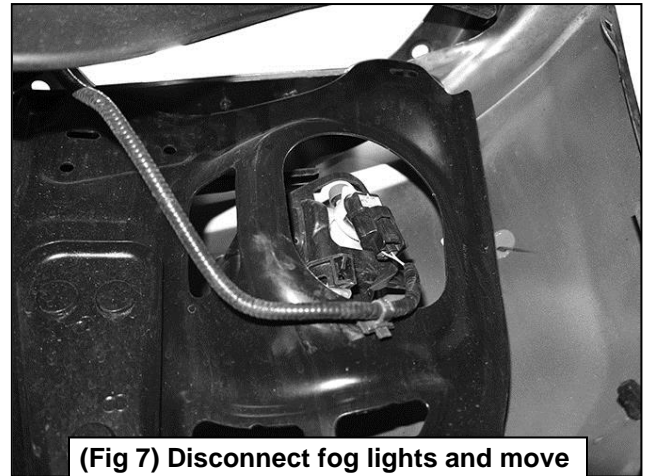

(Fig 7) Disconnect fog lights and move wiring harness away from bumper

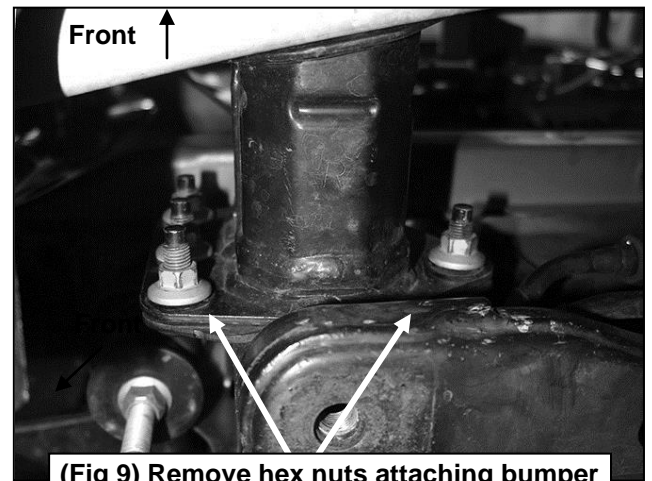

(Fig 9) Remove hex nuts attaching bumper brackets to end of frame. Passenger side bumper bracket pictured from below

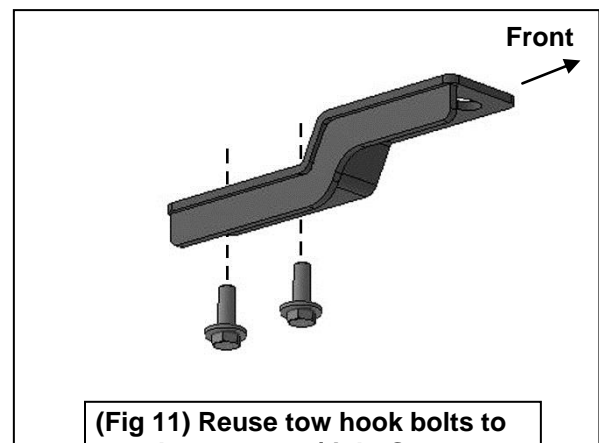

(Fig 11) Reuse tow hook bolts to attach passenger/right Support Bracket to bottom of frame



Front

(Fig 12) Reuse tow hook bolts (arrow) to attach passenger/right Support Bracket to bottom of frame

- (2) 12mm x 35mm Hex Bolts
- (2) 12mm Lock Washers
- (2) 12mm Flat Washers

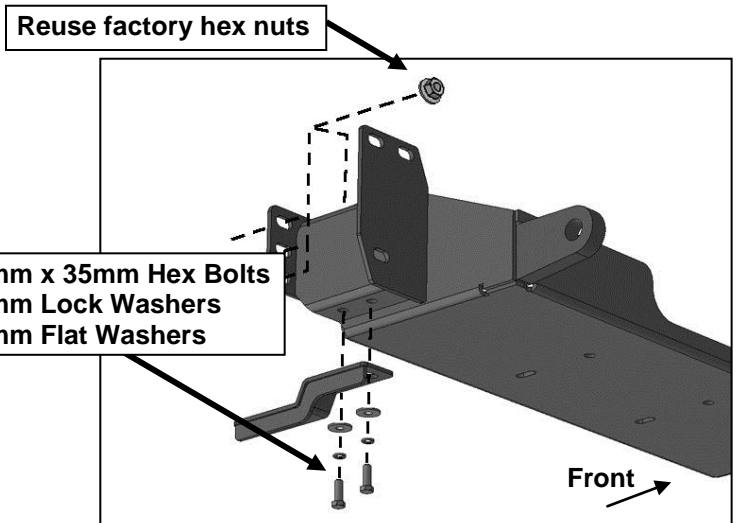

Reuse factory hex nuts

Front

(Fig 13) Reuse factory hex nuts to attach Winch Tray Bracket Assembly to end of frame

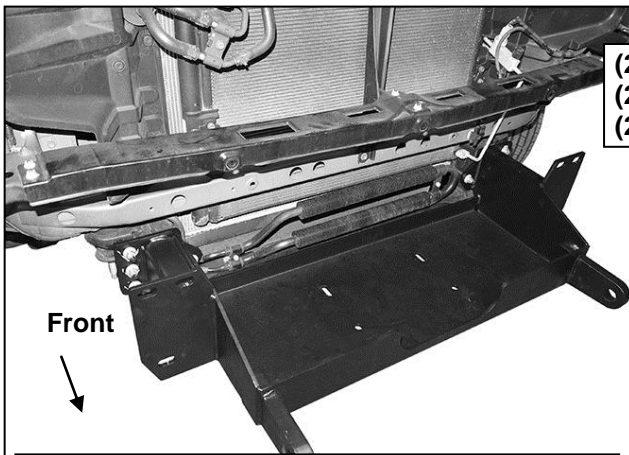

Front

(Fig 14) Reuse factory hex nuts to attach Winch Tray Bracket Assembly to end of frame

- (2) 8mm x 16mm Hex Bolts
- (2) 8mm Lock Washers
- (2) 8mm Flat Washers

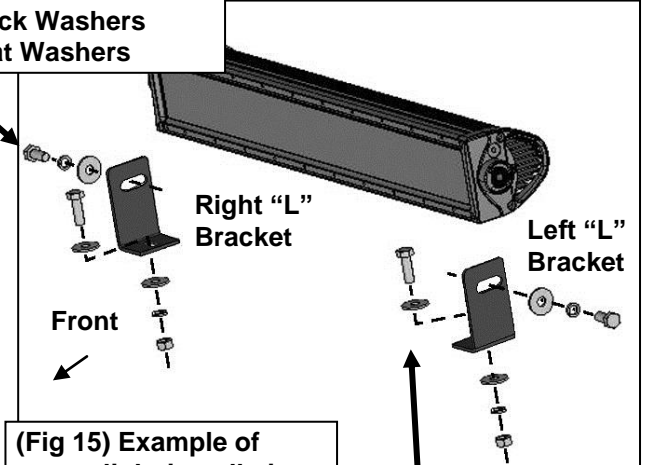

Right "L" Bracket

Left "L" Bracket

Front

(Fig 15) Example of center light installation

- (2) 8mm x 25mm Hex Bolts
- (4) 8mm Flat Washers
- (2) 8mm Lock Washers
- (2) 8mm Hex Nuts

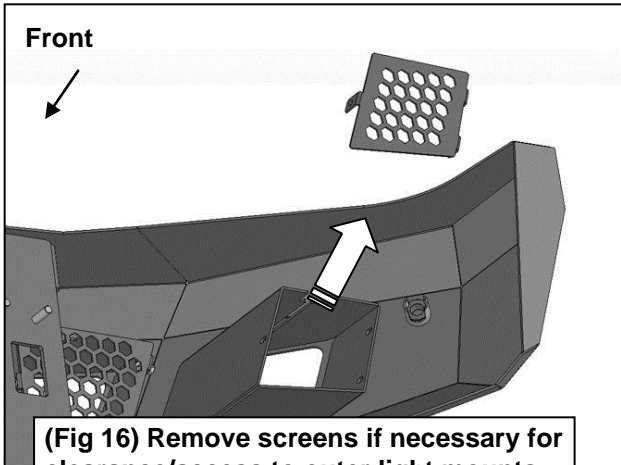

Front

(Fig 16) Remove screens if necessary for clearance/access to outer light mounts

- (2) 6mm x 20mm Button Head Screws
- (4) 6mm Flat Washers
- (2) 6mm Nylon Lock Nuts

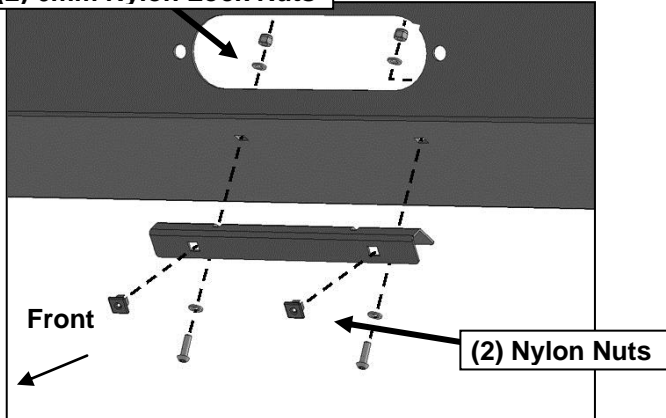

(Fig 17) Attach License Plate Bracket to Bumper

- (3) 10mm Flat Washers
- (3) 10mm Lock Washers
- (3) 10mm Hex Nuts

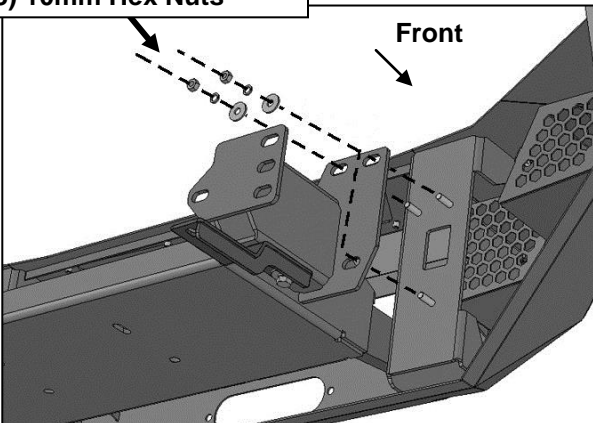

(Fig 19) Attach Bumper to Frame Brackets



IMPORTANT: Sensors fit snug in sockets. The 4mm Screws are only used to apply slight pressure to lock the sensors in place. Tighten both screws evenly until they touch the sensor body only. Do not overtighten screws or damage to sensors will result.

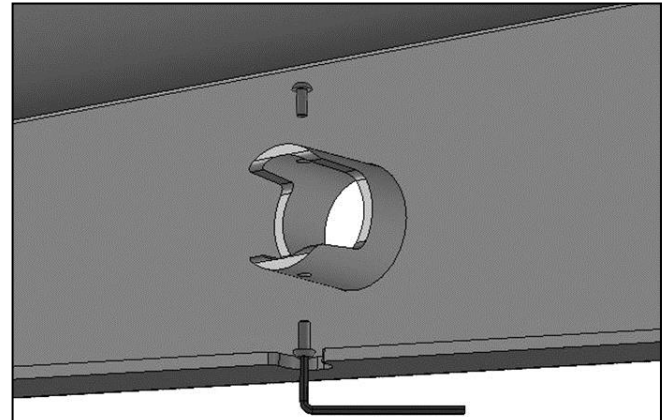

(Fig 18) Push sensor into mounting sleeve. Use 4mm Screws to lock sensor in place.

WARNING! Do not crawl under bumper unless the bumper is properly supported on blocks or stands or the bumper may fall.

- (3) 10mm Flat Washers
- (3) 10mm Lock Washers
- (3) 10mm Hex Nuts

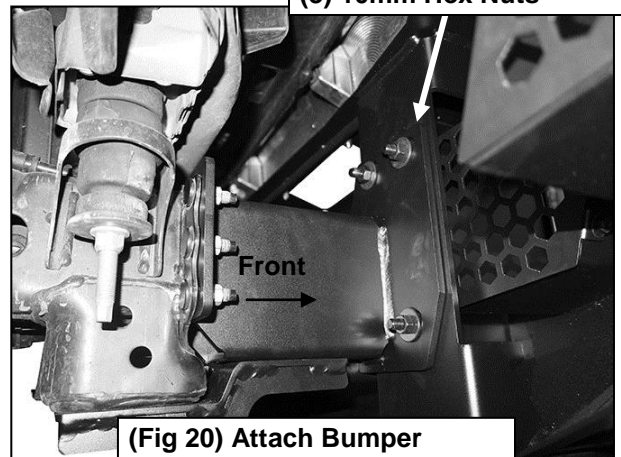

(Fig 20) Attach Bumper assembly to Frame Brackets