

## 2019-2023 SUBARU FORESTER HILINE FRONT WINCH BUMPER PART #SU-19340

### PARTS LIST:

1	BA Front Center Section Winch Bumper	2	12mm Lock Washers
1	Bull Nose Hoop	4	12mm Nylon Lock Nuts
1	Driver/left Frame Mounting Bracket	2	10-1.5mm x 25mm Hex Bolts
1	Passenger/right Frame Mounting Bracket	2	10mm x 30mm x 2.5mm Flat Washers
1	Winch Remote Adapter Bracket	2	10mm x 27mm x 3mm Flat Washers
1	Winch Fairlead Bracket	2	10mm Lock Washers
1	Grille Support Bracket	2	8-1.25mm x 25mm Button Head Bolts
1	Driver/left Shutter Support Bracket	2	8-1.25mm x 20mm Button Head Bolts
1	Passenger/right Shutter Support Bracket	8	8-1.25mm x 25mm Hex Bolts
1	Driver/left Light Bar "L" Bracket	16	8mm x 24mm x 2mm Flat Washers
1	Passenger/right Light Bar "L" Bracket	4	8mm x 16mm x 1.6mm Flat Washers
2	Inner Light Bar "L" Brackets	8	8mm Nylon Lock Nuts
1	License Plate Bracket	4	8mm Flanged Nylon Lock Nuts
2	Plastic Plugs	4	6-1.0mm x 25mm Button Head Combo Bolt
1	Edge Trim (2m length cut to fit)	4	6-1.0mm x 35mm Button Head Bolts
4	Splash Guard Support Brackets	4	6mm x 18mm x 1.6mm Flat washers
4	6mm Nut Plates for splash guard (19mm x 17mm)	4	6mm Lock Washers
2	12mm "L" Nut Plates	1	5mm Wrench
6	12-1.75mm x 40mm Hex Bolts	1	4mm Wrench
10	12mm x 32mm x 3mm Flat Washers		

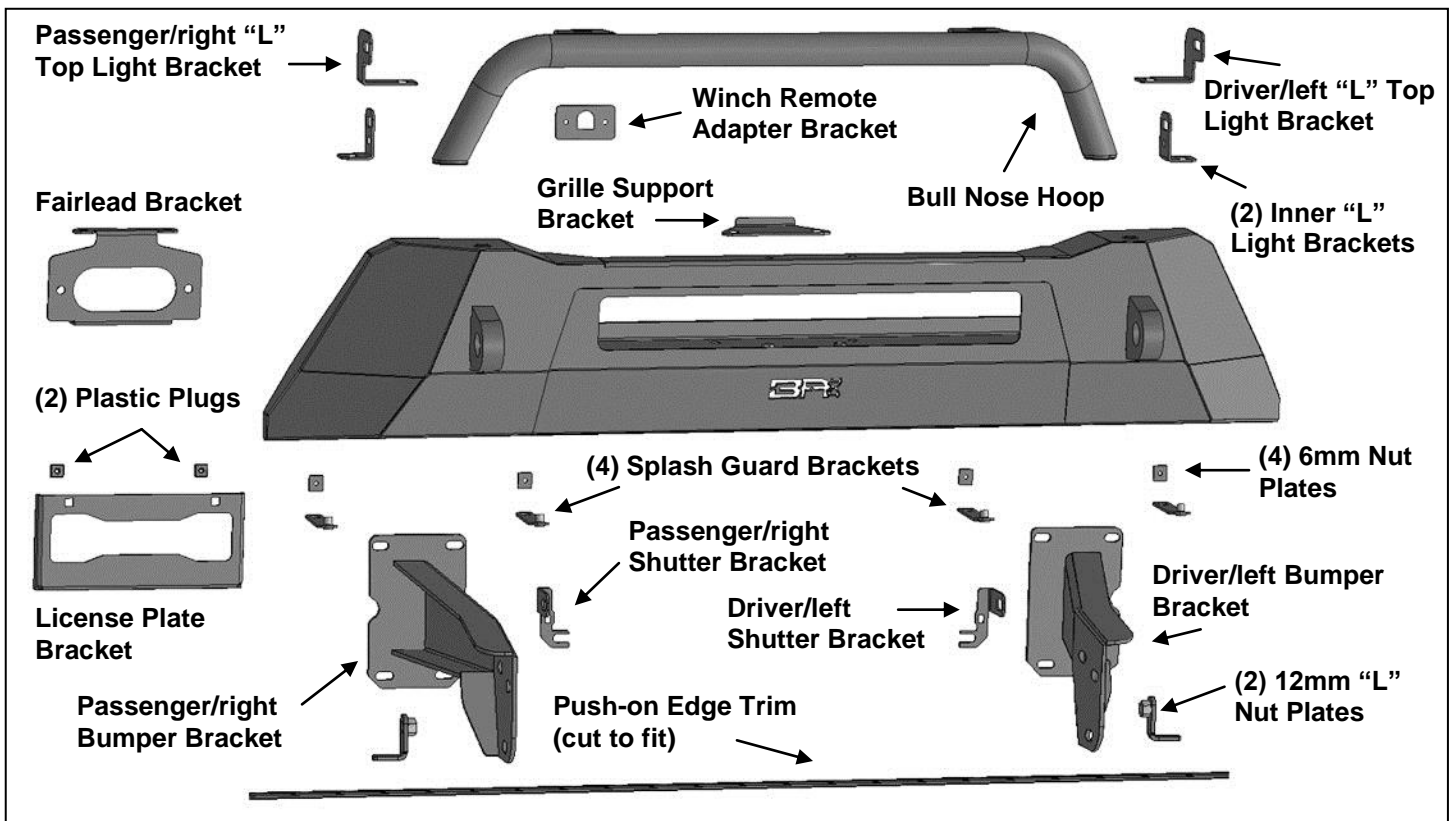



# INSTALLATION INSTRUCTIONS

## PROCEDURE:

**REMOVE CONTENTS FROM BOX. VERIFY ALL PARTS ARE PRESENT. READ INSTRUCTIONS CAREFULLY BEFORE STARTING INSTALLATION. ASSISTANCE IS RECOMMENDED TO AVOID POSSIBLE INJURY OR DAMAGE TO THE VEHICLE. CUTTING OE FRONT BUMPER IS REQUIRED.**

1. Start at the driver/left front wheel opening and remove the plastic push-in clip attaching the end of the bumper cover to the bottom of the front fender, **(Figure 1)**. Next, remove the plastic clips attaching the end and bottom of the bumper cover to the outer and center splash guards. Repeat this **Step** to remove the clip from the passenger/right wheel opening.
2. Open the hood and remove the (6) plastic clips attaching the top of the plastic bumper cover and grille to the radiator support and next to the headlights, **(Figure 2)**.
3. Place a blanket under the bumper to protect the painted finish. With assistance, pop the ends of the bumper cover off of the inner clips at the wheel openings and under the headlights. Pull the bumper cover off the vehicle, **(Figure 3)**. Unplug the fog lights if equipped.
4. Place bumper on a soft, clean work surface.
5. Remove the (2) hex bolts attaching the plastic splash guard and shutter assembly to the bottom of the bumper reinforcement, **(Figure 3)**. Remove the bumper reinforcement and brackets from the end of the frame, **(Figure 4)**.
6. Select the driver/left Bumper Bracket, **(Figure 5)**. Reuse the factory hardware to attach the Bracket to the (4) threaded holes in the body, **(Figure 6)**. Do not fully tighten hardware at this time. Repeat this **Step** to attach the passenger/right Bumper Bracket.
7. Locate and release the sensor located to the passenger/right side of the shutter assembly. Move sensor out of the way, **(Figure 7)**. **NOTE:** Use a pair of needle nose pliers to reach down into the pocket to release the tab on the sensor.
8. Next, locate the (4) mounting clip pockets in the back/top of the center splash guard, **(Figure 8)**. Place (1) 6mm Square Nut Plate into the outer driver/left pocket. Select (1) Splash Guard Support Bracket, **(Figure 9)**. Attach the Bracket to the bottom side of the splash guard and Nut Plate with (1) 6mm x 35mm Button Head Bolt, (1) 6mm Lock Washer and (1) 6mm Flat Washer. **NOTE:** Attach Bracket with threaded insert **UP**. Repeat this **Step** to attach remaining (3) Support Brackets to the center splash guard. Do not fully tighten hardware at this time.
9. Next, carefully unwrap and move the Body Armor Front Bumper to a stable surface.
10. **Bull Nose Installation.**
  - a. Remove rubber plugs from top of Bumper, **(Figure 10)**.
  - b. Attach Bull Nose to top of Bumper with included (2) 10mm x 25mm Hex Bolts, (2) 10mm Lock Washers and (2) 10mm x 30mm Large Flat Washers, **(Figure 10)**. Tighten hardware.
11. Determine if license plate, LED bar style light or winch will be installed.

### **Grille Support Bracket without winch.**

- a. Attach Grille Support Bracket to the top of the Bumper with the included (2) 8mm x 25mm Button Head Bolts, (2) 8mm x 24mm STD Flat Washers and (2) 8mm Flange Lock Nuts, **(Figure 11)**. If license plate is required, insert License Plate Bracket between Grill Bracket and top of Bumper.
- b. **NOTE:** Grille Support Bracket must be installed regardless of chosen options.

### **Center LED light installation without winch (sold separately).**

- a. Follow previous **Step** to install Grille Support Bracket and optional License Plate Bracket.
- b. Select (1) Inner "L" Light Bracket, **(Figure 12)**. Use the provided (1) 8mm x 25mm Hex Bolt, (2) 8mm x 24mm STD Flat Washers and (1) 8mm Nylon Lock Nut to attach the "L" Bracket to the mounting tabs on the back of the Bumper. Leave hardware loose. Repeat to install the passenger/right Bracket.
- c. Attach the LED light assembly to the "L" Brackets.
- d. Adjust the light as necessary and tighten hardware.
- e. Follow the instructions included with the light to connect the wire harness to the vehicle.

**Winch installation without center LED light** (sold separately).

- a. Attach Cable Guide Bracket, (guide sold separately), to winch tray inside of Bumper with (2) 8mm x 25mm Hex Bolts, (4) 8mm x 24mm STD Flat Washers and (2) 8mm Nylon Lock Nuts, **(Figure 13)**.
  - b. Attach the top of the Cable Guide Bracket to the Bumper, Grille Support Bracket and optional License Plate Bracket with the included (2) 8mm x 25mm Button Head Bolts, (2) 8mm x 24mm STD Flat Washers and (2) 8mm Flange Lock Nuts, **(Figure 13)**.
  - c. Next, attach the cable guide to the Bracket with the included (2) 8mm x 20mm Button Head Bolts, (2) 8mm x 24mm STD Flat Washers, (2) 10mm x 27mm x 3mm Thick Spacer Washers, and (2) 8mm Flange Locking Nuts, **(Figure 14)**. **NOTE:** 10mm Spacer Washers only required with roller cable guide installation.
  - d. Attach the winch to the center mounting plate on the back of the Bumper.
  - e. With assistance, hold the Bumper with winch up in position on the vehicle to check for clearance. Adjust or modify vehicle for clearance as necessary but do not install Hiline Bumper at this time.
  - f. Follow instructions packaged with winch to install winch and connect electrical system.
12. With assistance, position the Bumper Assembly up to the outside of the Brackets. Temporarily support the weight of the Bumper. **WARNING:** To avoid possible injury or damage to the vehicle, do not proceed until the bumper is fully and safely supported.
  13. Attach the driver/left side of the Bumper to the top two mounting slots in the Bracket with (2) 12mm x 40mm Hex Bolts, (4) 12mm Flat Washers and (2) 12mm Nylon Lock Nuts, **(Figures 15 & 16)**. Insert (1) 12mm "L" Nut Plate up between the bottom of the Bumper Bracket and plastic splash guard, **(Figures 15 & 16)**. Attach the Nut Plate to the Bumper and Bracket with (1) 12mm x 40mm Hex Bolt, (1) 12mm Lock Washer and (1) 12mm Flat Washer, **(Figure 17)**. Leave hardware loose at this time. Repeat this **Step** to attach the passenger/right side of the Bumper.
  14. Remove the top/rear 12mm Hex Nut and Washer, **(Figure 18)**. Select the driver/left Shutter Support Bracket. Attach the Bracket to the upper rear Bumper to Bracket Hex Bolt, **(Figure 19)**. Attach the slot in the bottom of the Support Bracket to the shutter assembly with the included (1) 8mm x 25mm Hex Bolt, (2) 8mm x 16mm Small Flat Washers and (1) 8mm Nylon Lock Nut, **(Figure 20)**. Repeat this **Step** to attach the passenger/right Shutter Support Bracket. Snap the sensor into the square hole in the Shutter Support Bracket, **(Figure 21)**. **NOTE:** It may be necessary to unwrap a portion of the wiring harness to extend it to fit into the Support Bracket.
  15. Attach the (4) Splash Guard Support Brackets to the back of the bottom of the Bumper with the included (4) 6mm Button Head Combo Bolts, **(Figures 22 & 23)**. Do not fully tighten hardware.
  16. Move to the back of the plastic bumper cover. Locate the raised trim line below the bottom of the grille, running side to side. Use removable tape (masking tape for example) to make a guide line following along the highest point of the trim line, **(Figures 24 & 25)**.
  17. On the passenger/right side of the bumper cover, locate the bottom mounting tab, **(Figure 24)**. Use the tape to make a vertical guide line from the front edge of the tab up to the raised trim line and tape guide line. Repeat this **Step** to make a vertical guide line on the driver/left side of the bumper cover.
  18. Use a sharp knife or hacksaw blade to carefully cut the plastic bumper cover along the previously marked lines, **(Figure 26)**. **IMPORTANT:** For best fit, leave an extra 1/4" of material when cutting to allow for any adjustments as necessary.
  19. Check fitment of the trimmed plastic bumper cover over the Hiline Bumper. Trim the plastic cover as required. Level and adjust the Hiline Bumper as needed and tighten the Hiline Bumper hardware.
  20. Reinstall the cut plastic bumper cover, **(Figure 26)**. Check the fit of the plastic bumper cover against the Hiline Bumper. Once all trimming is completed, cover the cut edge of the bumper cover with the included Edge Trim, **(Figure 26)**. Cut the Edge Trim to fit as required. Reattach the fog light wiring harness and reinstall the bumper cover at this time.
  21. Align and adjust the bumper and cover and fully tighten all hardware.

- 22. **Top LED light installation (optional, light not included).** Select the (1) driver/left "L" Light Bracket, (Figure 12). Use the provided (1) 8mm x 25mm Hex Bolt, (2) 8mm x 24mm STD Flat Washers and (1) 8mm Nylon Lock Nut to attach the "L" Bracket to the mounting tab. Repeat to install the passenger/right Bracket. Follow instructions packaged with light to attach light to Brackets.
- 23. Insert (2) Plastic Plugs into the square holes in the License Plate Bracket for license plate, (Figure 28).
- 24. Do periodic inspections to the installation to make sure that all hardware is secure and tight.

**To protect your investment,** Do not use any type of polish or wax that may contain abrasives that could damage the finish. Mild soap may be used to clean the Bumper assembly.

### Driver/left side Installation Pictured

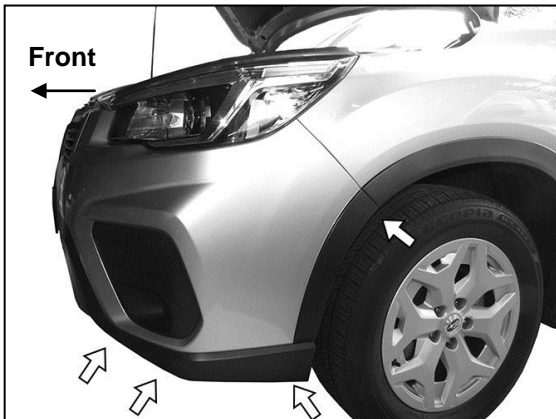

(Fig 1) Remove clips attaching ends and bottom of plastic bumper cover (arrows)

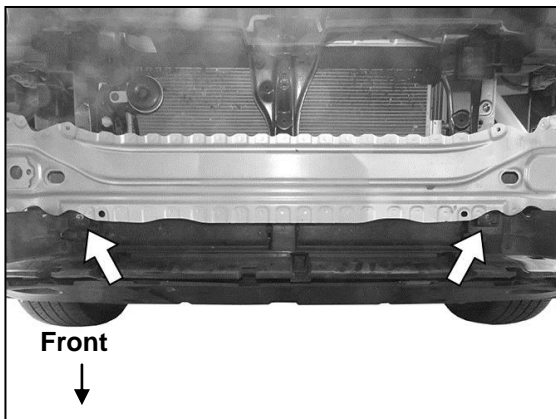

(Fig 3) Remove (2) hex bolts below bumper reinforcement (arrows)

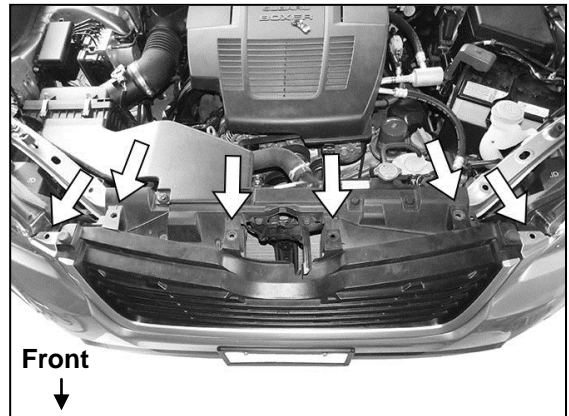

(Fig 2) Remove (6) clips attaching top of grille (arrows). Pull bumper cover at ends and below headlights to release inner clips. Unplug fog lights if equipped

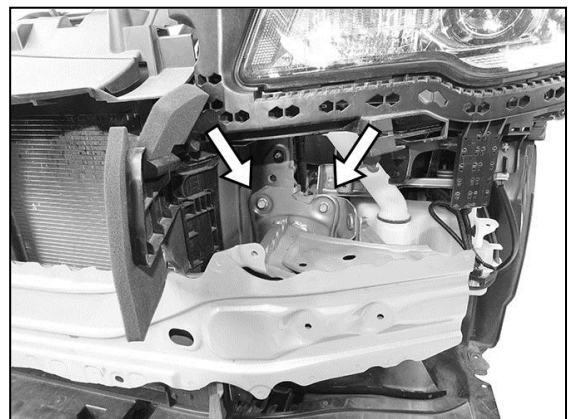

(Fig 4) Remove factory hex bolts to remove bumper reinforcement (arrows)

## Driver/left side Installation Pictured

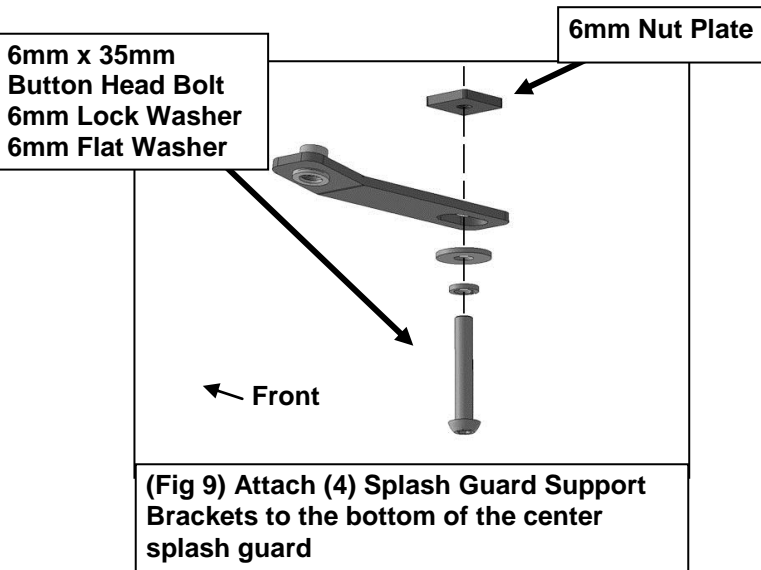
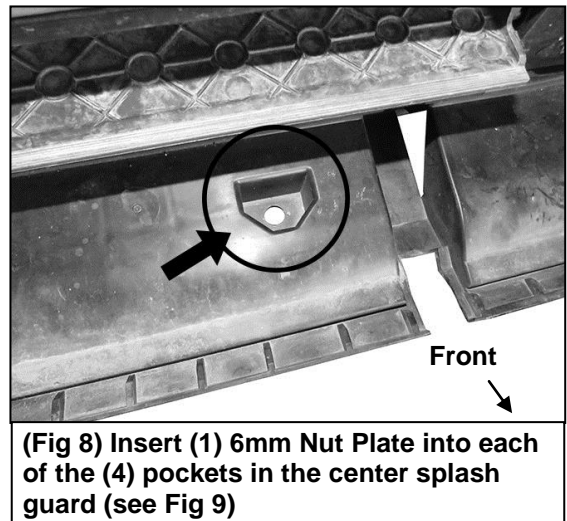
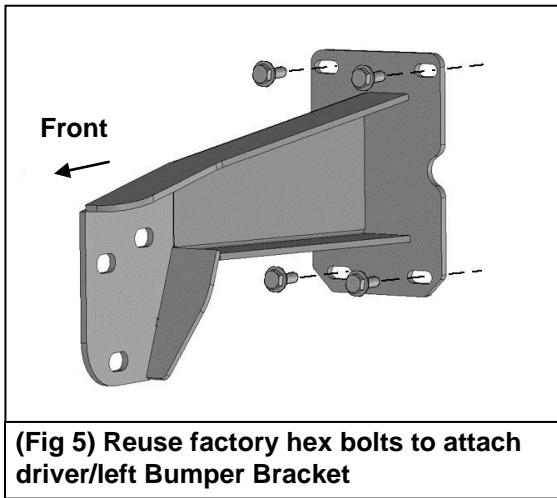

## Driver/left side Installation Pictured

Rubber Plug

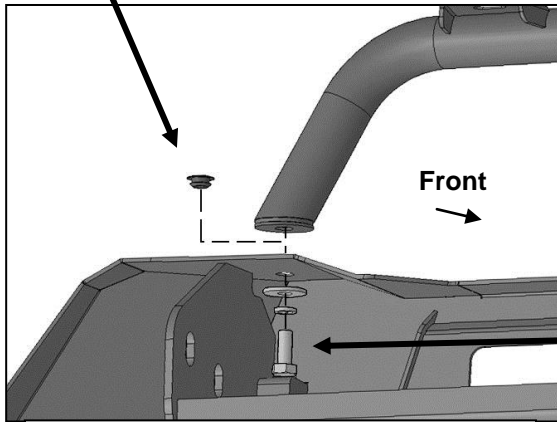

10mm x 25mm Hex Bolt  
10mm Lock Washer  
10mm x 30mm Large Flat Washer

(Fig 10) Remove rubber plug to attach Bull Nose Hoop to top of Bumper

License Plate Bracket (optional)

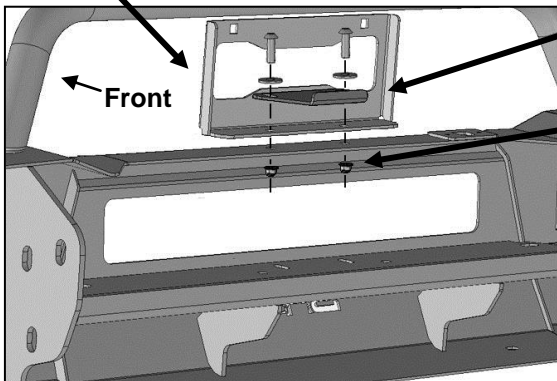

Grille Support Bracket (must install)

(2) 8mm x 25mm Button Head Bolts  
(2) 8mm STD Flat Washers  
(2) 8mm Flange Lock Nuts

(Fig 11) Models without winch, attach Grille Support Bracket and License Plate Bracket (if required)

8mm x 25mm Hex Bolt  
(2) 8mm STD Flat Washers  
8mm Nylon Lock Nut

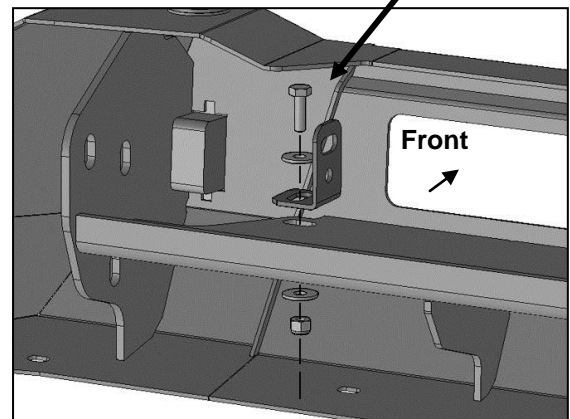

(Fig 12) Models without winch, attach "L" Brackets to mounting holes in tray. Attach LED bar style light (not included) to "L" Brackets

## Driver/left side Installation Pictured

8mm x 25mm Hex Bolt  
 (2) 8mm STD Flat Washers  
 8mm Nylon Lock Nut

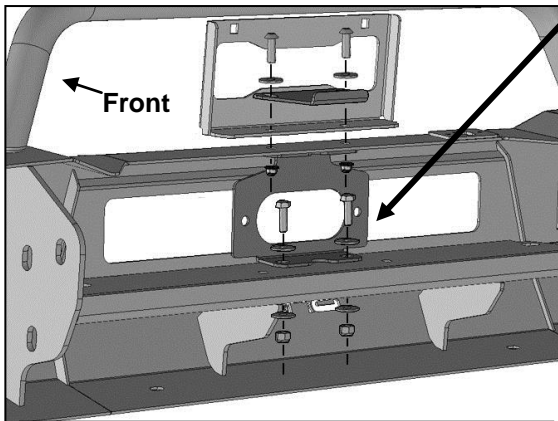

(Fig 13) Models with winch, attach cable guide Bracket to inside of Bumper

(2) 8mm x 20mm Button Head Bolts  
 (2) 8mm x 24mm STD Flat Washers  
 (2) 10mm x 27mm Thick Spacer Washers  
 (2) 8mm Flange Lock Nuts

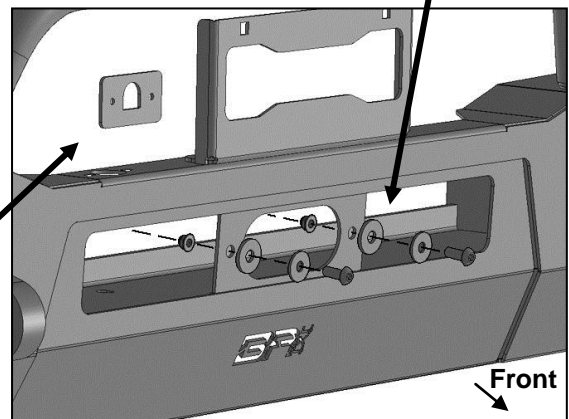

(Fig 14) Attach fairlead, (not included), to front of Bracket. On roller style fairleads, use 10mm thick Flat Washers as spacers between Bracket and cable guide

Use Adapter Bracket, if necessary, to attach the winch remote to the top of the Bumper

Top location  
 (2) 12mm x 40mm Hex Bolts  
 (4) 12mm Flat Washers  
 (2) 12mm Nylon Lock Nuts

Bottom location  
 12mm x 40mm Hex Bolt  
 12mm Lock Washer  
 12mm Flat Washer  
 12mm "L" Nut Plate

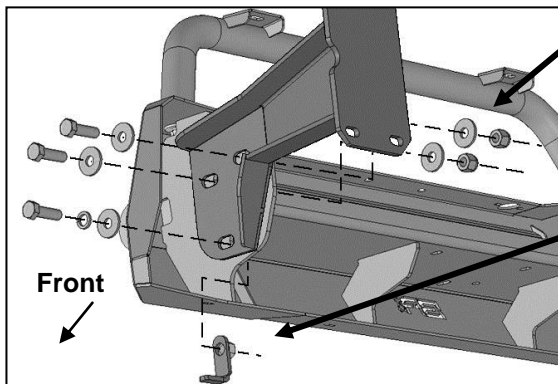

(Fig 15) Attach Bumper to inside of the Brackets. Use the "L" Nut Plate to reach the back of the Bumper

Driver/left side Installation Pictured

12mm x 40mm Hex Bolt  
12mm Lock Washer  
12mm Flat Washer

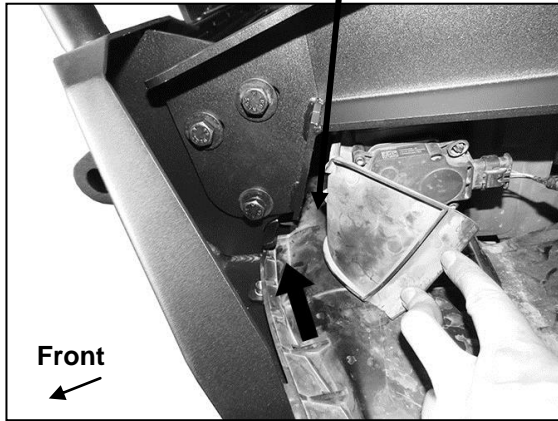

(Fig 17) Insert 12mm "L" Nut Plate into and up behind Bumper (arrow)

Attach top of Bumper first

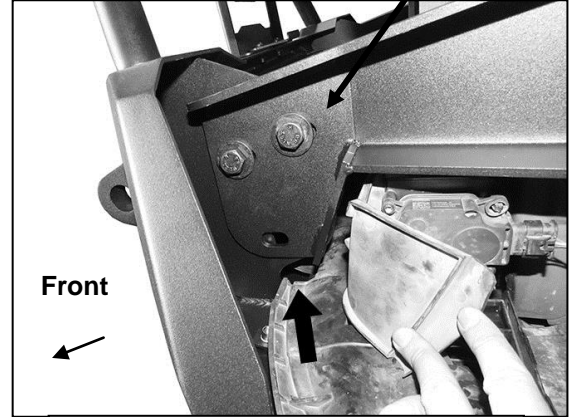

(Fig 16) Insert 12mm "L" Nut Plate into and up behind Bumper (arrow)

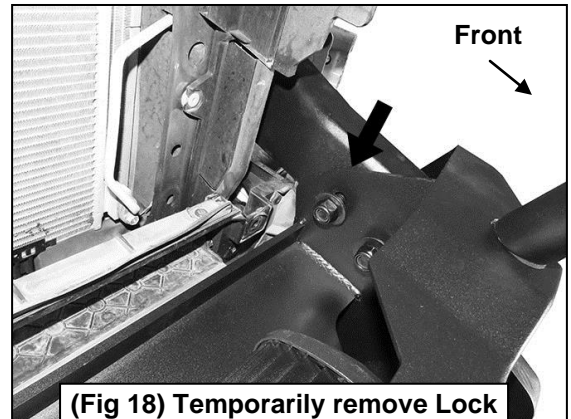

(Fig 18) Temporarily remove Lock Nut and Flat Washer (arrow)

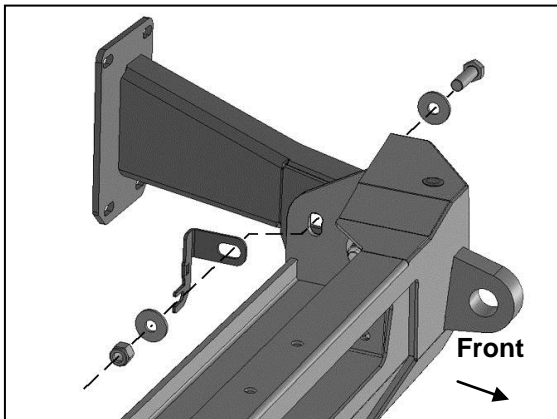

(Fig 19) Attach driver/left Shutter Support Bracket to top/rear Bumper Bolt



# INSTALLATION INSTRUCTIONS

Driver/left side Installation Pictured

- 8mm x 25mm Hex Bolt
- (2) 8mm x 16mm Small Flat Washers
- 8mm Nylon Lock Nut

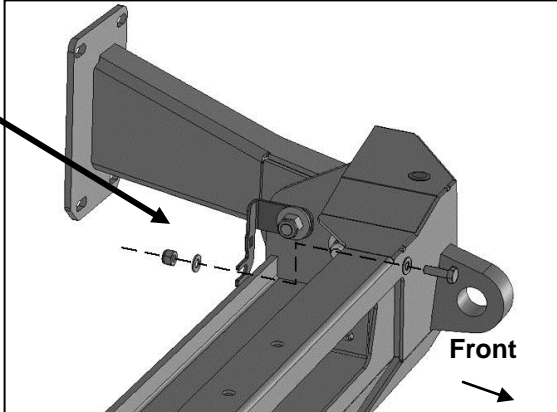

(Fig 20) Attach driver/left Shutter Support Bracket to shutter assembly

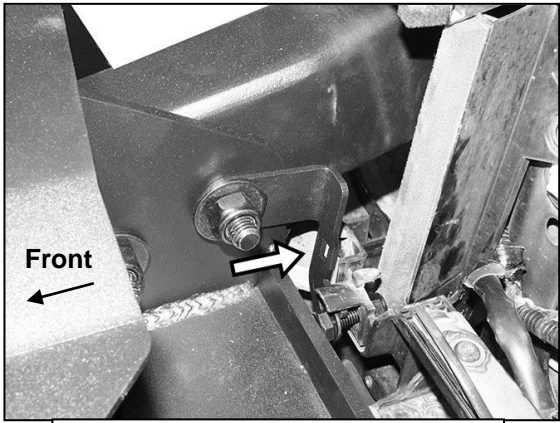

(Fig 21) Snap sensor into hole in passenger/right Shutter Support Bracket (also see Fig 7, Step 7)

- (4) 6mm Combo Bolts

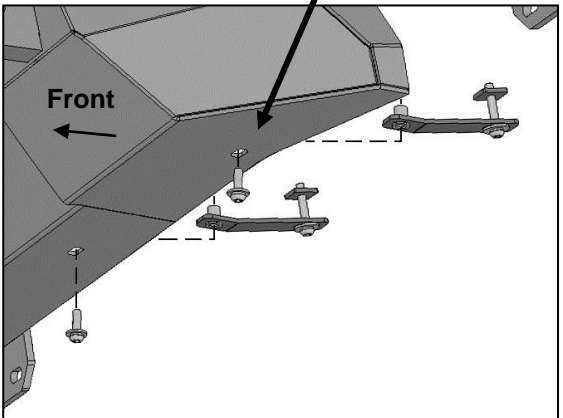

(Fig 22) Attach Splash Guard Support Brackets to back of Bumper (also see Fig 8)



(Fig 23) Attach Splash Guard Support Brackets to back of Bumper (also see Fig 8)

## Driver/left side Installation Pictured

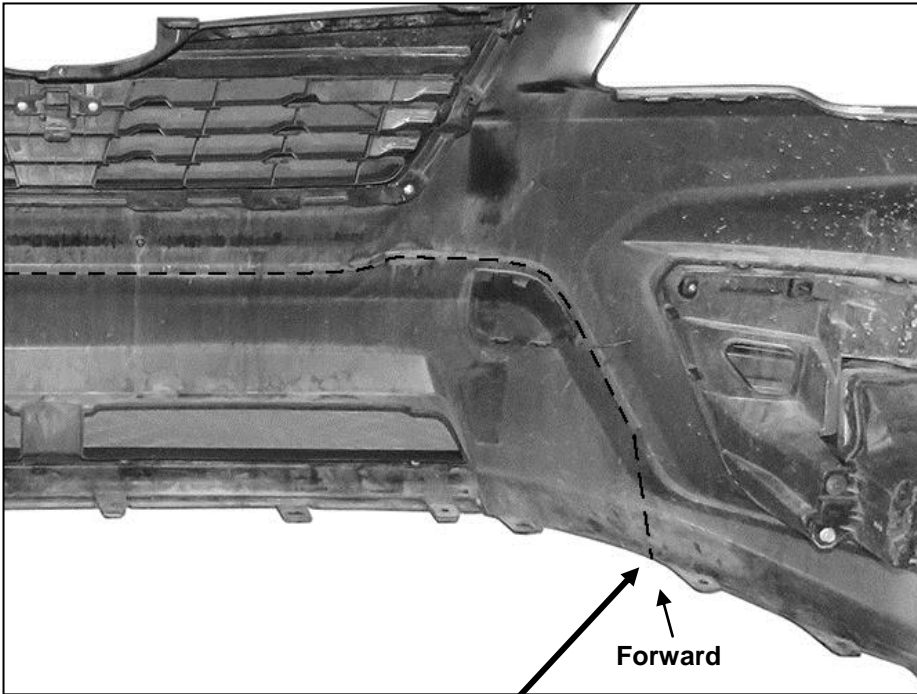

(Fig 24) Looking straight forward, draw a vertical line from the bottom of the bumper cover, in front of the mounting tab, up to the raised rib on the bumper. Follow raised rib to driver/left side of bumper and repeat vertical line. Dashed line represents suggested starting point for cutting, additional trimming may be required for a proper fit

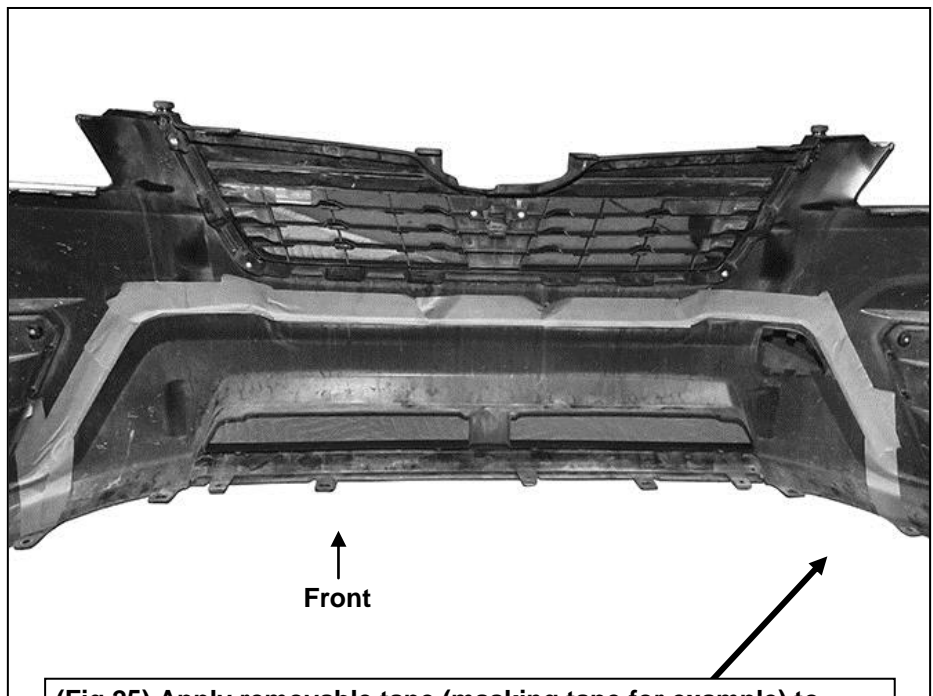

(Fig 25) Apply removable tape (masking tape for example) to back of bumper for a cutting guide and to protect bumper cover

Driver/left side Installation Pictured

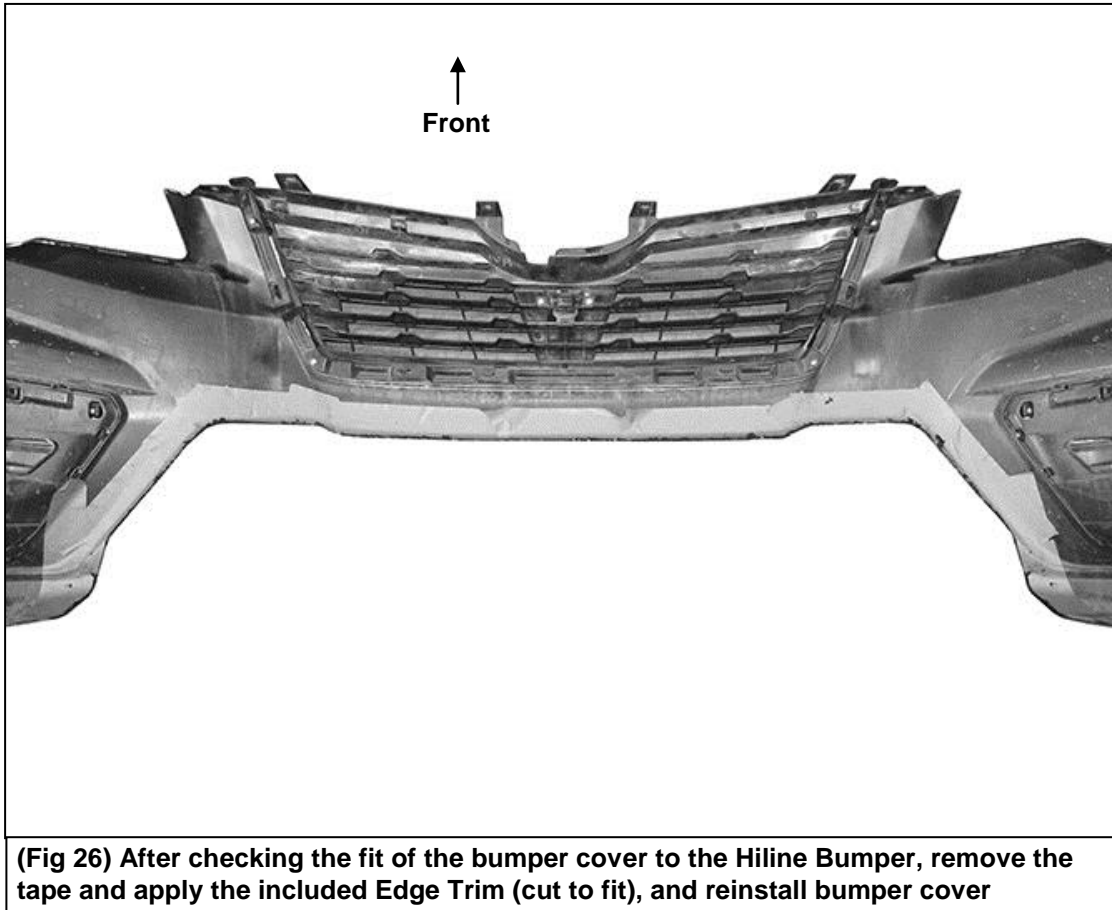

(Fig 26) After checking the fit of the bumper cover to the Hiline Bumper, remove the tape and apply the included Edge Trim (cut to fit), and reinstall bumper cover

8mm x 25mm Hex Bolt  
(2) 8mm STD Flat Washers  
8mm Nylon Lock Nut

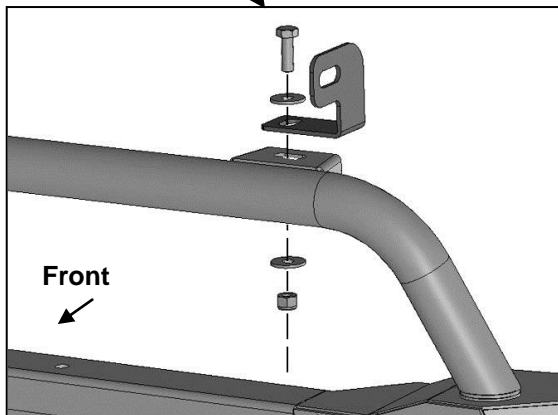

(Fig 27) Attach driver/left "L" Top Light Bracket to tab on Bumper Hoop

(2) Plastic Plugs

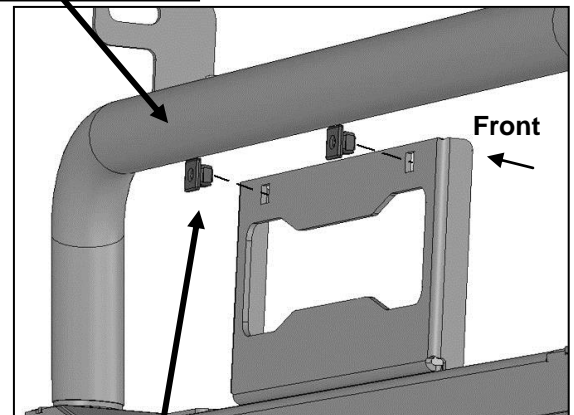

(Fig 28) Attach license plate to Plastic Plugs