

## 2012-2015 TACOMA HILINE FRONT WINCH BUMPER PART #TC-19340

### PARTS LIST:

1	Hiline Front Bumper	2	12mm x 32mm OD x 3mm Flat Washers
1	Bull Nose Hoop	2	12mm Lock Washers
1	Driver/Left Reinforcement Bracket	2	12mm Hex Nuts
1	Passenger/Right Reinforcement Bracket	4	10-1.50mm x 90mm Hex Bolts
1	Driver/Left Inner Support Plate	2	10-1.50mm x 25mm Hex Bolts
1	Passenger/Right Inner Support Plate	2	10-1.50mm x 25mm Button Head Bolts
1	Driver/Left Lower Support Bracket	2	10mm Lock Washers
1	Passenger/Right Lower Support Bracket	2	10mm x 30mm OD x 2.5mm Flat Washers
1	License Plate Bracket	12	10mm x 20mm OD x 2mm Flat Washers
2	L-Brackets	6	10mm Nylon Lock Nuts
1	Rubber Edge Trim	4	8-1.25mm x 25mm Hex Bolts
2	License Plate Plugs	8	8mm x 24mm OD x 2mm Flat Washers
2	12-1.75mm x 120mm Hex Bolts	4	8mm Nylon Lock Nuts
2	12mm x 44mm OD x 4mm Flat Washers	1	6mm Hex Wrench

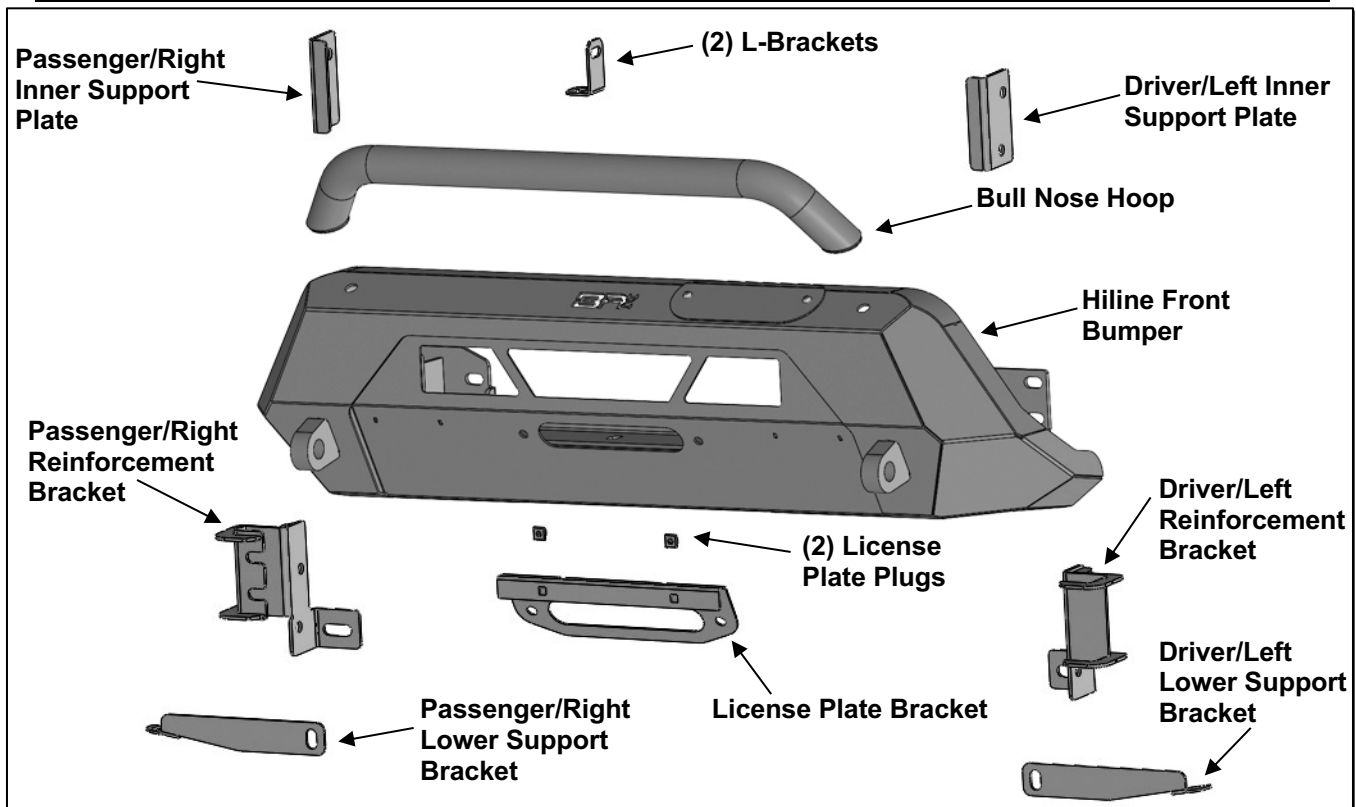

### PROCEDURE:

REMOVE CONTENTS FROM BOX. VERIFY ALL PARTS ARE PRESENT. READ INSTRUCTIONS CAREFULLY BEFORE STARTING INSTALLATION. ASSISTANCE IS RECOMMENDED TO AVOID POSSIBLE INJURY OR DAMAGE TO THE VEHICLE. CUTTING OE FRONT BUMPER IS REQUIRED.

1. Remove the skid plate, if equipped, (Figure 1).
2. Open the hood and carefully remove the plastic grille, (Figure 2).

3. **Remove the factory bumper**
  - a. Remove the plastic covers under each headlight, **(Figure 3)**.
  - b. Remove the factory hardware attaching the front bumper to the wheel well, **(Figure 4)**.
  - c. Remove the hardware attaching the bottom of the bumper to the vehicle, **(Figure 5)**.
  - d. Remove the hardware attaching the top of the bumper to the vehicle, **(Figure 6)**. Carefully remove the plastic bumper away from the vehicle.
  - e. Remove the hardware attaching the crossbar to the frame, **(Figure 7)**. Place the hardware in a safe location.
4. **For cutting the bumper**
  - a. Locate all pins attaching the center cover to the bumper. Remove all of the pins and remove the cover, **(Figures 8 & 9)**.
  - b. Use tape to mark the center of the bumper for cutting, **(Figures 9 & 10)**.
5. **(OPTIONAL)**: Select the Bull Nose Hoop. Attach the Hoop to the top of the Bumper with (2) 10mm x 25mm Hex Bolts, (2) 10mm Lock Washers and (2) 10mm x 30mm Flat Washers, **(Figure 11)**.
6. Select (1) L-Bracket. Attach the Bracket to the back of the bumper with (1) 8mm Hex Bolt, (2) 8mm Flat Washers and (1) 8mm Nylon Lock Nut, **(Figure 12)**. Repeat this **Step** to attach the remaining (1) L-Bracket to the Driver/Left side of the Bumper.
7. With assistance, attach the Bumper and Reinforcement Brackets to the end of the frames by reusing the factory hardware, **(Figures 13—15)**. **NOTE**: The Reinforcement Brackets go in between the Bumper mounting plates and the factory hardware.
8. Select the Passenger/Right Inner Support Plate. Attach the Bracket to the frame with (2) 10mm x 90mm hex Bolts, (4) 10mm x 20mm Flat Washers and (2) 10mm Nylon Lock Nuts, **(Figure 16)**. Do not tighten hardware at this time. Repeat this **Step** to attach the Driver/Left Inner Support Plate.
9. Reinstall the cut plastic bumper cover. Select the Passenger/Right Lower Support Bracket. Attach the Bracket to the frame with (1) 12mm x 120mm Hex Bolt, (1) 12mm x 32mm Flat Washer, (1) 12mm x 40mm Flat Washer, (1) 12mm Lock Washer and (1) 12mm Hex Nut, **(Figure 17)**. Do not tighten hardware at this time.
10. Attach the (2) Lower Support Brackets to the bottom of the factory bumper with (2) 8mm Hex Bolts, (4) 8mm Flat Washers and (2) 8mm Nylon Lock Nuts, **(Figure 18)**. Do not tighten hardware at this time.
11. Repeat **Steps 9 & 10** to attach the Driver/Left Lower Support Bracket.
12. Select the License Plate Bracket. Attach the Bracket to the front of the bumper with (2) 10mm Button Head Bolts, (4) 10mm x 20mm Flat Washers and (2) 10mm Nylon lock Nuts, **(Figure 19)**. Insert the (2) License Plate Plugs into the Bracket to attach the License Plate, **(Figure 20)**. Do not tighten hardware at this time.
13. Level and adjust the Bumper and tighten all hardware.
14. Reinstall the Grille.
15. Reinstall the skid plate, if equipped.
16. Do periodic inspections to the installation to make sure that all hardware is secure and tight.

**To protect your investment**, Do not use any type of polish or wax that may contain abrasives that could damage the finish. Mild soap may be used to clean the Bumper assembly.

Driver/Left side Installation Pictured

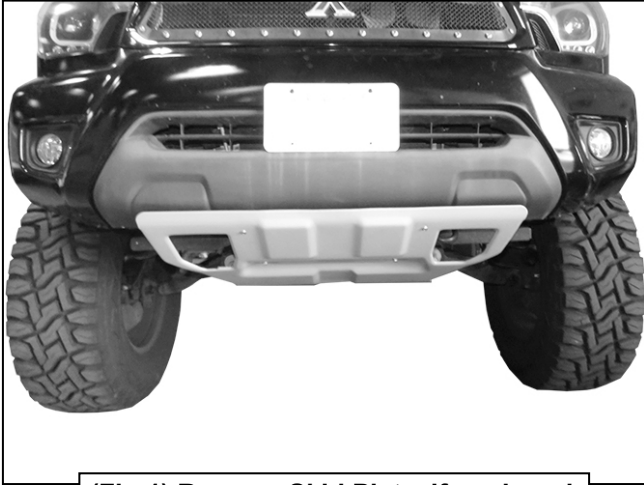

(Fig 1) Remove Skid Plate, if equipped

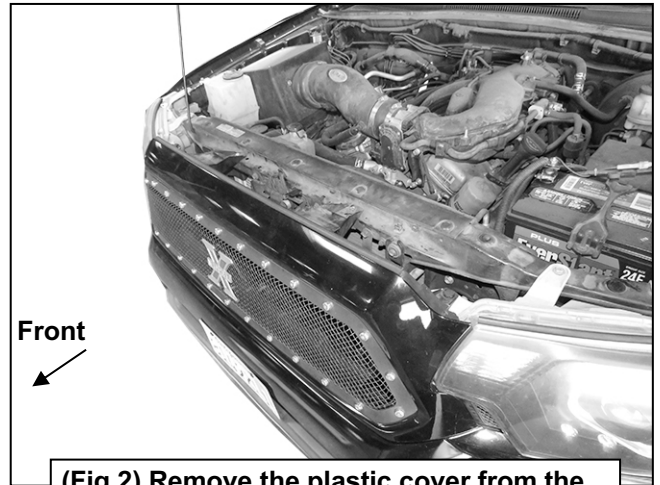

(Fig 2) Remove the plastic cover from the top of the radiator. Remove grille assembly

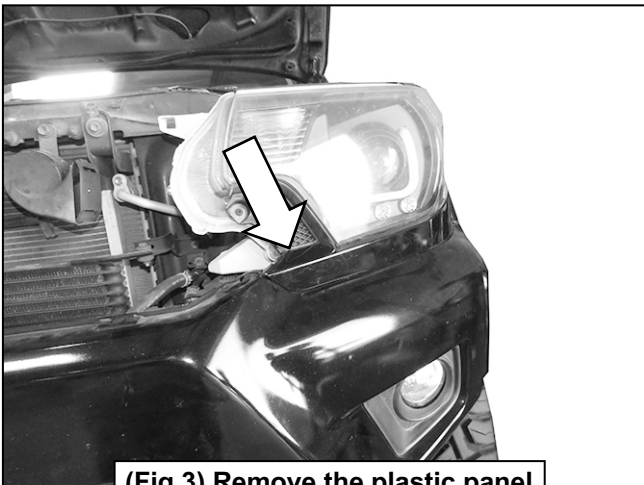

(Fig 3) Remove the plastic panel underneath the headlights

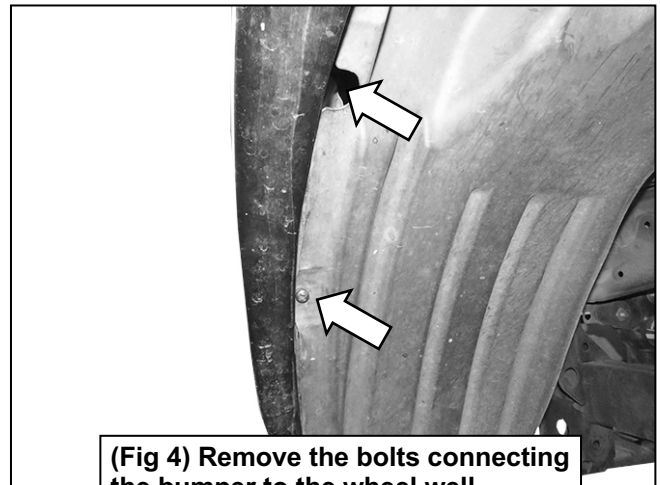

(Fig 4) Remove the bolts connecting the bumper to the wheel well

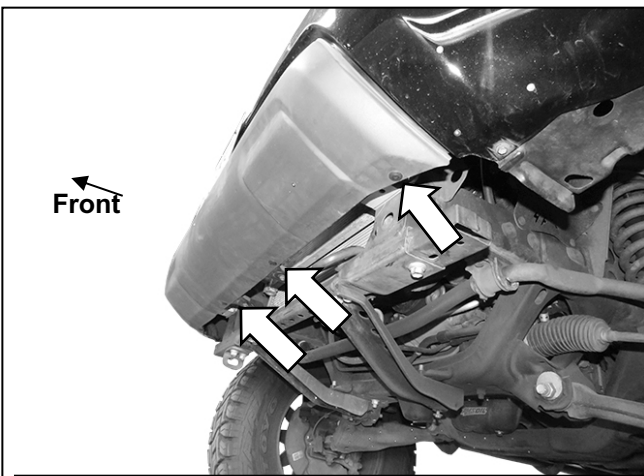

(Fig 5) Remove the factory hardware connecting the bottom of the bumper to the vehicle

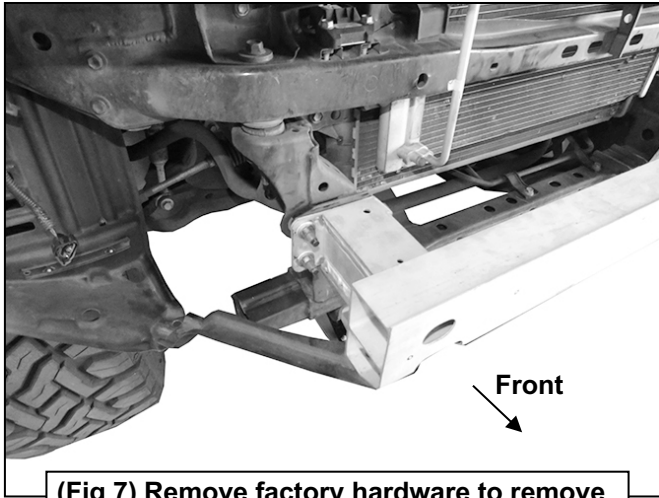

(Fig 7) Remove factory hardware to remove the crossbar, save hardware for later

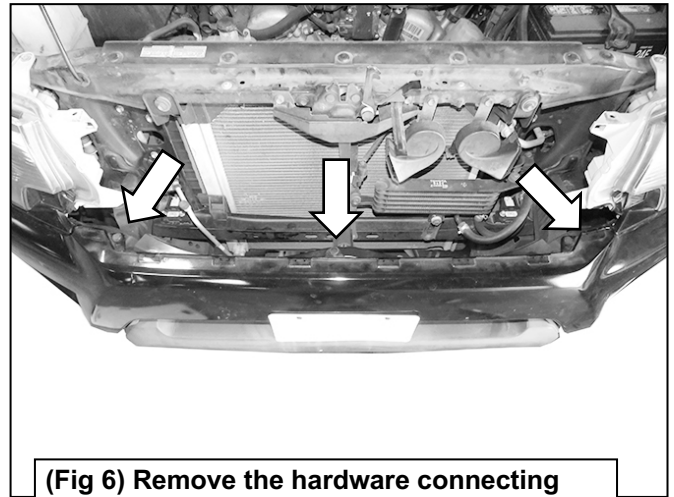

(Fig 6) Remove the hardware connecting the top of the bumper to the vehicle

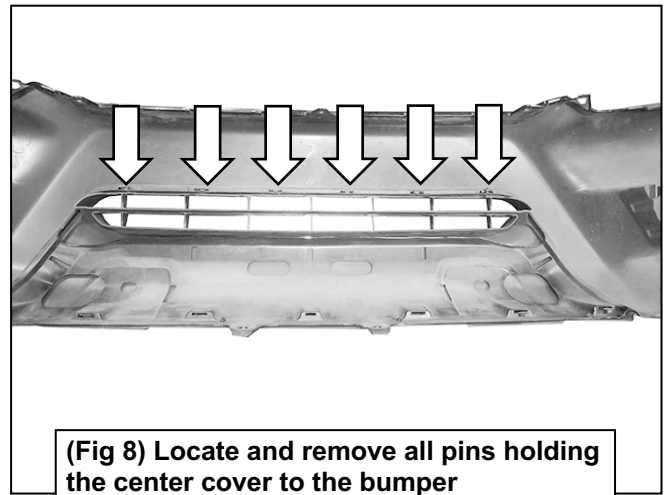

(Fig 8) Locate and remove all pins holding the center cover to the bumper



(Fig 9) Cut and trim the center panel to allow installation of Hiline Bumper

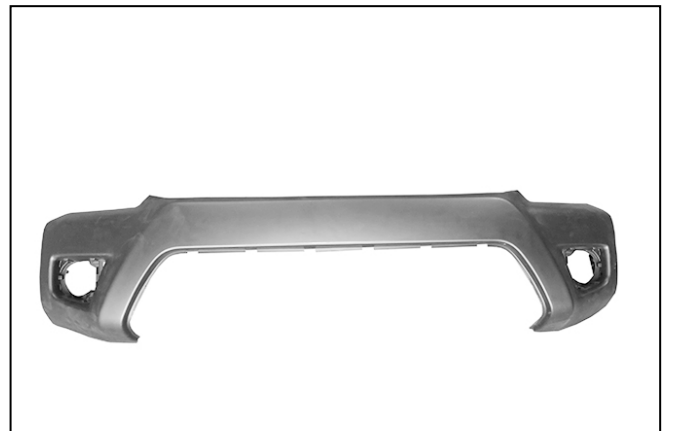

(Fig 10) Line the new cut edge with the Rubber Edge Trim to prevent scratches to the Hiline Bumper

10mm x 25mm Hex Bolt  
10mm Lock Washer  
10mm x 30mm Flat Washer

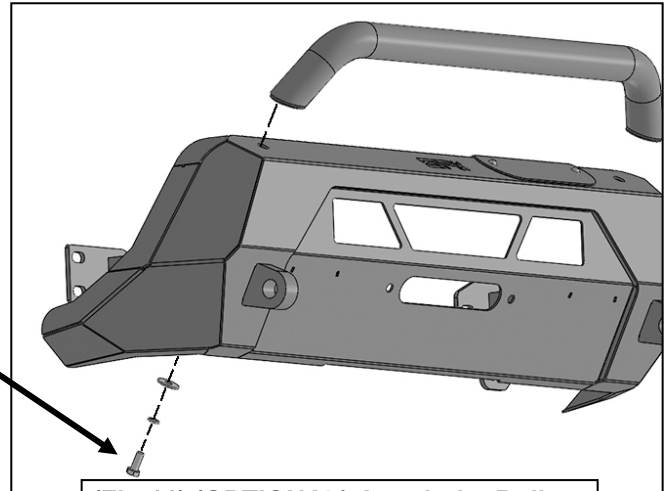

(Fig 11) (OPTIONAL) Attach the Bull Nose Hoop to the top of the Bumper

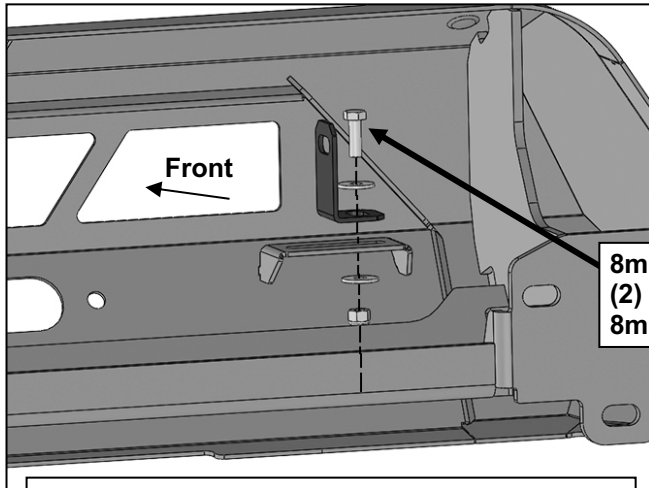

8mm Hex Bolt  
(2) 8mm Flat Washers  
8mm Nylon Lock Nut

(Fig 12) Attach (1) L-Bracket to the back of the Bumper to attach light (light sold separately)

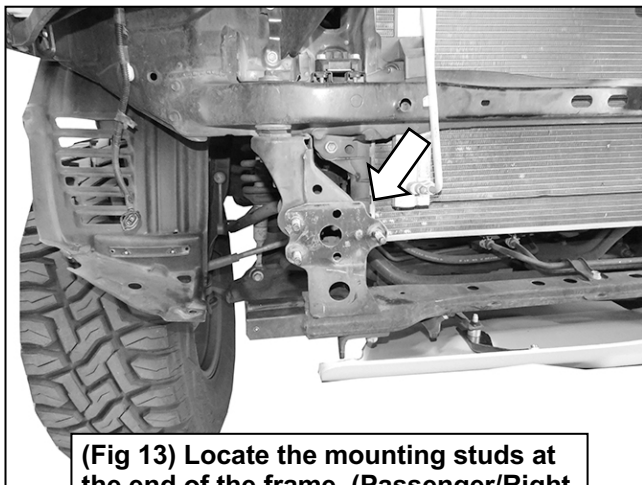

(Fig 13) Locate the mounting studs at the end of the frame. (Passenger/Right mounting location shown)

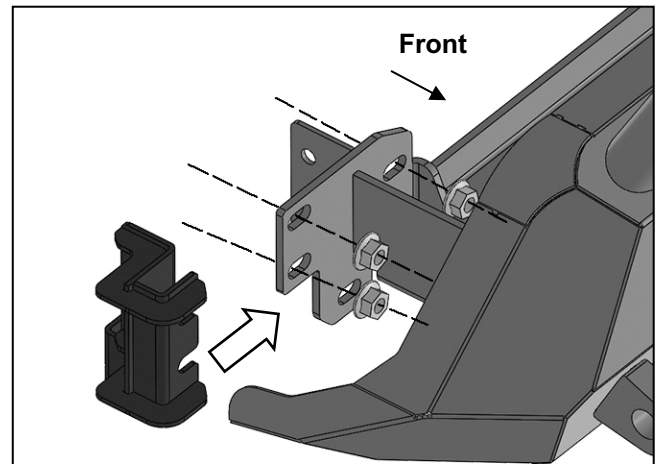

(Fig 14) Reuse the factory hardware to attach the Bumper and Reinforcement Bracket to the frame

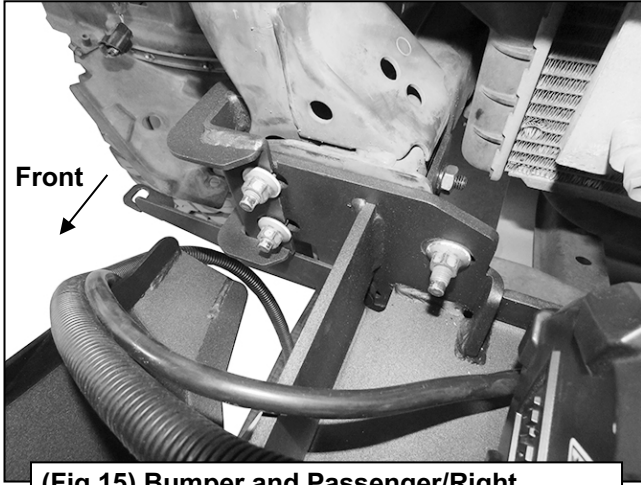

(Fig 15) Bumper and Passenger/Right Reinforcement bracket attached to the frame

- (2) 10mm x 90mm Hex Bolts
- (4) 10mm x 20mm Flat Washers
- (2) 10mm Nylon Lock Nuts

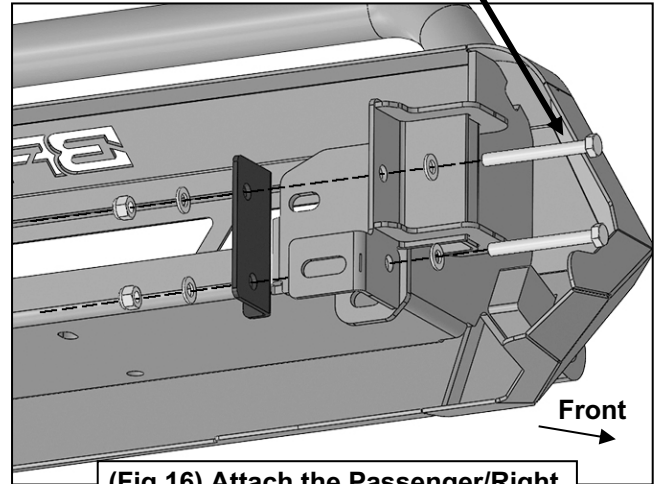

(Fig 16) Attach the Passenger/Right Inner Support Bracket to the frame

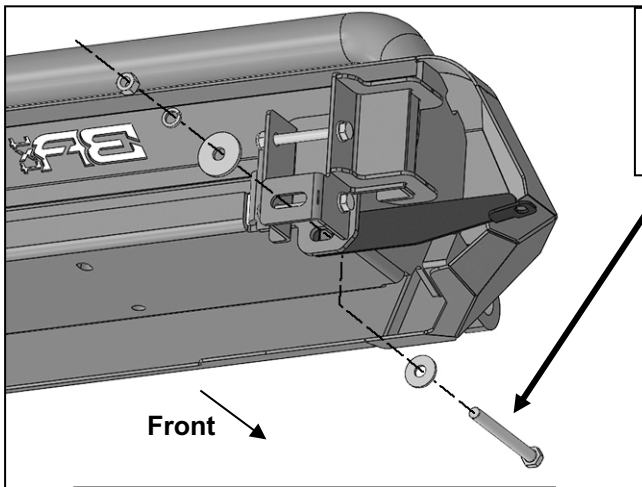

(Fig 17) Attach the Passenger/Right Support Bracket to the frame

- 12mm x 120mm Hex Bolt
- 12mm x 32mm Flat Washer
- 12mm x 40mm Flat Washer
- 12mm Lock Washer
- 12mm Hex Nut

- 8mm Hex Bolt
- (2) 8mm Flat Washers
- 8mm Nylon Lock Nut

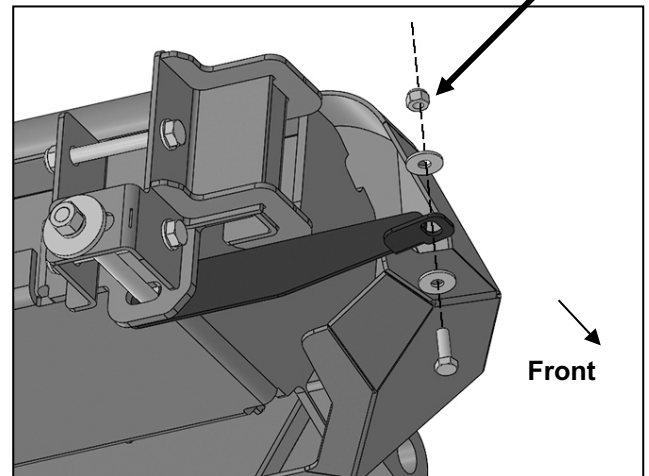

(Fig 18) Attach the Passenger/Right Lower Support Bracket to the side of the factory bumper

- (2) 10mm Button Head Bolts
- (4) 10mm x 20mm Flat Washers
- (2) 10mm Nylon Lock Nuts

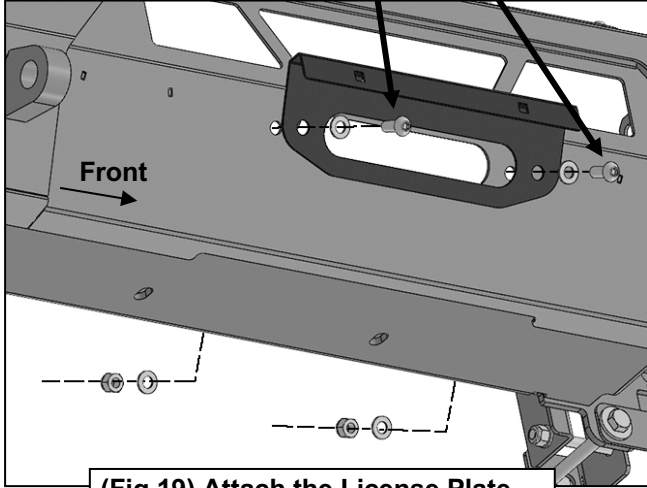

(Fig 19) Attach the License Plate Bracket to the front of the Bumper

- (2) License Plate Plugs

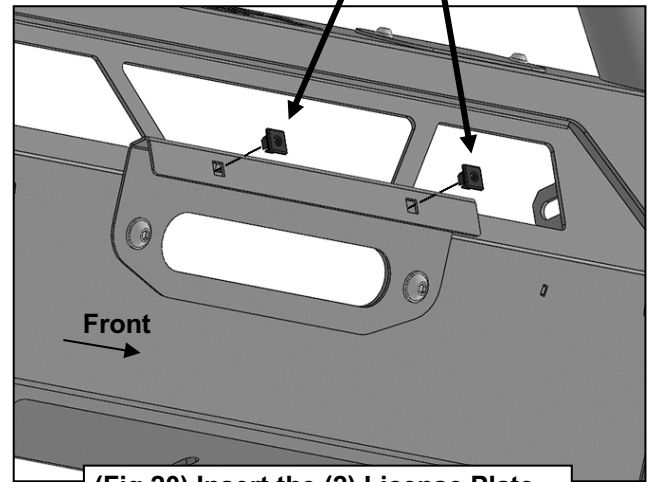

(Fig 20) Insert the (2) License Plate Plugs into the License Plate Bracket