

Glass thickness: 5/16" up to 1 11/16" .

Bronze mineral-finish metal moulding .

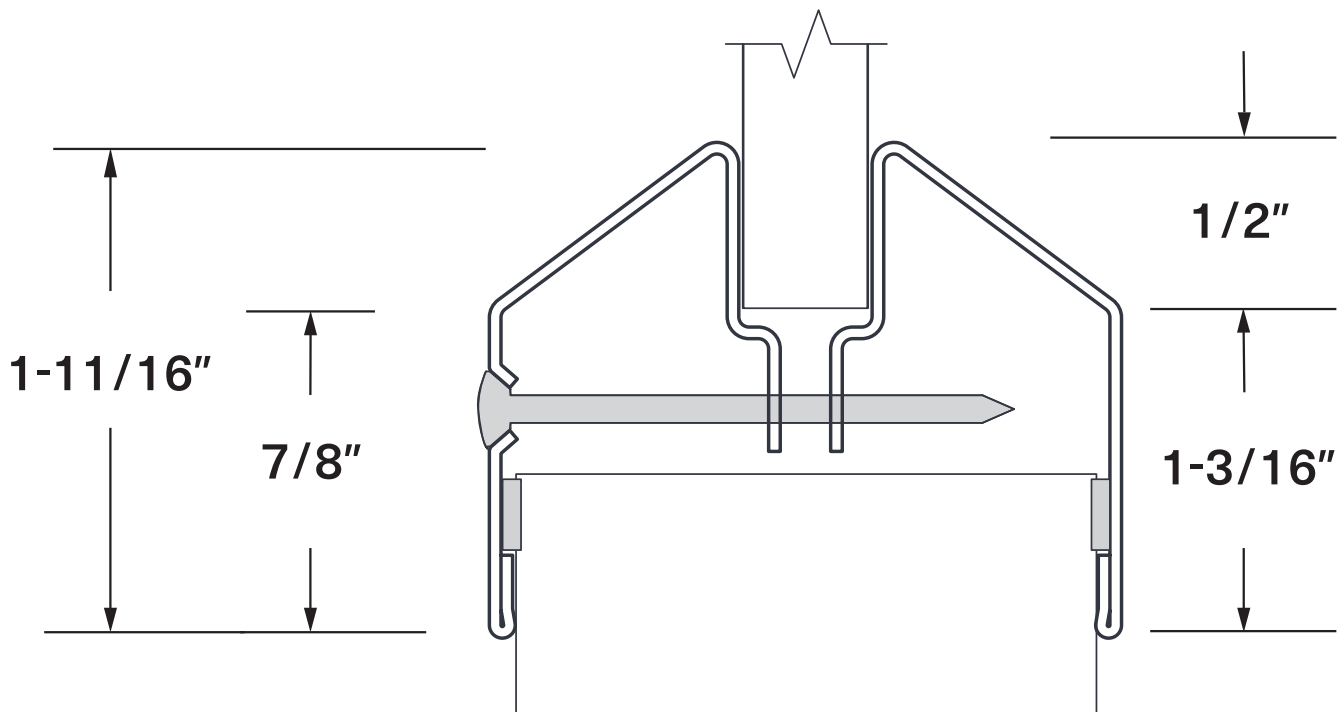

Metal moulding mineral bronze paint. 20-gauge.

- Core components come pre-measured to standard sizes that vary depending on door size and intended use.
- Standard sizes are suitable for the following door sizes: 3'0" x 7'0", 3'6" x 7'0", and 3'0" x 8'0". Custom sizes available on request.
- The face must be glued to the core in accordance with industry standards for 1 3/4" 5-ply flush doors.
- Sanding of the face is acceptable; however, a minimum door thickness of 1 1/2" must be maintained.
- Specifications are based on a 3'0" x 7'0" test door.
- All STC tests are carried out with a specific sound-rating hardware configuration.
- Extra heavy duty hinges are recommended.
- Some hatches have been tested and can affect STC performance. Contact us for any construction modification or required hatches.
- Any hardware not installed using through bolts must be properly tightened.
- All levels of STC performance require specific sealing products and procedures.
- We supply sealing products with door assembly. Upon request, sealing products can be purchased at your convenience from a tested and approved manufacturer.
- Please refer to installation specifications for sealants.
- Sealant must be adjusted to door thickness and width according to manufacturer's specifications and third party testing.