

# AT-100

## Technical Datasheet

Easy handling shaft alignment - introducing a new generation of solutions.

- . Fast and accurate results are delivered by intelligent sensor technology.
- . Step-in shaft alignment that is easy to use and affordable at the same time.
- . Reports in PDF format show the alignment process and results in detail. Reports can be easily shared.
- . Live animations of the engine's position make the measurement and horizontal alignment intuitive and easy.
- . A scalable tool of the global Augmented Mechanics Ecosystem.



### Accurate shaft alignment results that are faster and easier to perform



Make an accurate alignment by determining soft foot presence with **SoftCheck™**



Easily align horizontal and vertical machines with Acoem **Vertizental™** feature in only one move and save significant time



Automatic alignment quality assessment according to Tolerances based on tolerances with graphical and color-coded results



Unvalued shaft alignment precision with down to **1 % accuracy** in the values displayed



**Acoem GuideU™** makes it simple to align rotating assets following the highly visual interface. In addition to universal, color-coded and icon-based graphics, the interface will empower the operator and eliminate human error from the alignment process.



**Acoem True Live™** allows you to track the shaft positions in real time.



**Screen Flip** enables you to see the machine set-up from the actual view that you have of the machine.

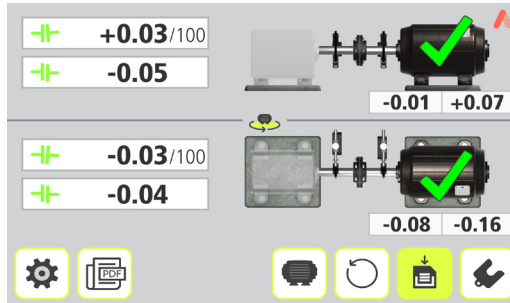
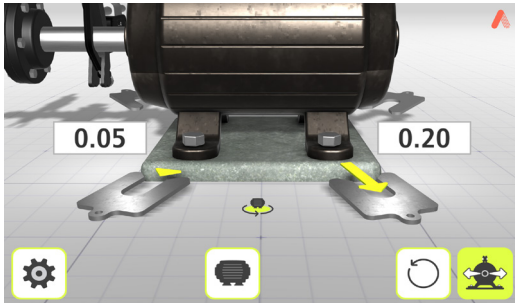
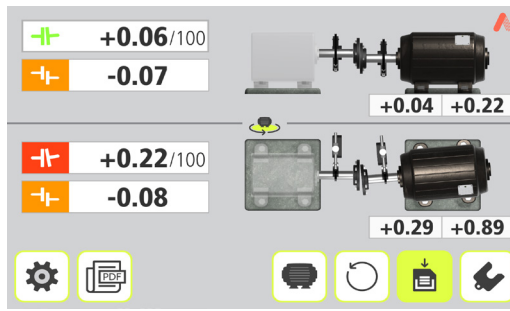
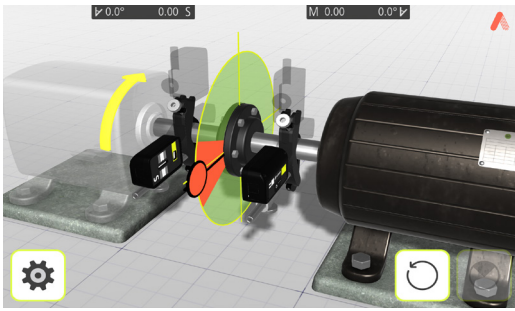

### Tripoint™ method

In the Tripoint method, the alignment condition can be calculated by taking three points while rotating the shaft at least 60°. In this method, all points are taken manually.

## Share reports from your mobile device!



Instantly generate an automatic **PDF report**. Easily create and share a PDF report containing all measurement data and images



Take pictures of your machines and setup to illustrate automatically in the PDF report



Utilize all the communication tools available on your mobile devices to share your reports (email, WhatsApp...)



## Sensor Specifications

Hardware Type	M8 / S8
<b>Sensors</b>	
Housing Material	Anodized Aluminum frame and high impact ABS plastic
Weight	M8: 222 g (7,8 oz), S8: 222 g ww (7,8 oz)
Dimensions	94 mm x 87 mm x 37 mm (3,7 in x 3,4 in x 1,4 in)
<b>Environment</b>	
Operating Temp	0 to 50 °C (32 to 122 °F)
Storage Temp	-20 to 70 °C (-4 to 158 °F)
Long term storage Temp Room Temp	18 to 28 °C (64 to 82 °F)
Battery Charging Temp	0 to 40 °C (32 to 104 °F)
Relative humidity	10 – 90 %
Environmental protection	IP54 (Dust and flush-proof)
<b>Sensing Technology</b>	
Laser	650 nm class II diode laser
Laser power	< 1 mW
Measurement distance	Up to 2 m
Detector	Digital line sensor
Detector length	20 mm (1,2 in)
Detector resolution	0,01mm
Measurement accuracy	1 % ± 1 digit
Measuring Error	< 0.5%±5µm
Inclinometer resolution	0.1 °
Inclinometer accuracy	±3 °
<b>Battery</b>	
Type	High performance Li Ion battery or external power.
Operating time	12 h
Charging	8 h
Battery Capacity	10.4 Wh
LED indicators	Wireless communication, laser transmission and battery status indicators
<b>Communication</b>	
Wireless communication	Class I Bluetooth transmitter
Communication range	10 m (33 ft)
Connectors	1 USB Mini port Charging: 5V, 0,5A
<b>Handheld Algiz RT8 (optinal)</b>	

A sunlight-readable, 8-inch capacitive multi-touch display with super-hardened Gorilla Glass, plus rain and glove mode.

IP67 ruggedness rating (including the ports) for fullywaterproof and dust-tight performance.

Wide operating temperatures of -20°C to 60°C (-4°F to 140°F).

## Packaging & Deliverables

Each AT-100 is delivered with the following package:

- Sensor, M8/S8
- Rod kit NXA
- Chain 12,7 mm 60 links (L=500 mm)
- Tape measure 5 m
- V-bracket complete
- Angled universal tool - 1 pcs
- USB-cable A-mini B 2m
- Power supply 2 USB-ports 5 VDC



## Integrated into the Augmented Mechanics system

Build your own Augmented Mechanics solution and complete your shaft alignment tool with complementary applications on the same mobile device



Acoem Pre-alignment app designed to remove the complexity of your laser alignment process, making it faster and more reliable (Requires optional equipment)



Acoem Bearing Defender app providing quick first-level information on bearing health based on vibration readings in just few a matter of seconds (Requires optional equipment)



Acoem Machine Defender app, AI-powered vibration diagnostics instantly in the field for most rotating equipments in industrial environment (Requires optional equipment)

*Freely Download the Horizontal alignment app!*

