



DSL-800

Laser Backscatter Particulate Monitor

Ideal for monitoring particulate levels in the exhaust gas of industrial combustion or air filtration processes.

The DSL-800 is an optical instrument which uses the laser backscatter measurement technique. The monitor is designed to measure the concentration of particulate matter in an exhaust gas passing through a duct, stack or flue; typically the exhaust gas from an industrial combustion process or air filtration system.

The DSL-800 consists of a single Transceiver (TRX) head that is mounted on one side of the stack only. The TRX head emits a beam of laser light into the stack and any light backscattered from suspended particles is detected by the TRX.

Increased particulate density in the stack gas produces an increase in the level of the scattered light. When calibrated against a standard reference measurement, the measured backscattered light can be used to calculate the particulate concentration and present a reading in mg/m^3 .

The laser source in the DSL-800 is a visible (red) laser that is pulsed to give immunity to ambient light.

The optical configuration of the TRX head has been designed to measure the light scatter from well into the stack but to be insensitive to scatter from the far wall. This means that a light dump is not required.

The intensity of the transmitted light is monitored so that any variations in the emitted light level are compensated in the detected scatter signal.

The monitor features on board temperature measurement to provide stability over the operating temperature range and has the capability of automatic zero and span checking.

The DSL-800 is an intelligent analyser which can operate as a “stand-alone” instrument with all electrical connections (including the alarm relays, 4-20 mA analogue outputs and RS485 ModBus RTU) being made at the TRX head.

As a stand-alone instrument the DSL-800 is set-up and controlled using the supplied utility software, installed on a PC or laptop, and connected via the USB connector on the TRX.

The DSL-800 is also available with the DSCU operator interface. When supplied with the DSCU all power supply and output connections are made in the DSCU rather than the TRX.

The DSCU is a wall mounted control unit consisting of a numeric / directional keypad, a two-line LCD display and a terminal compartment, which allows full command and control of the instrument. The DSCU is suitable for mounting locally to the instrument or remotely, such as in a control room.

Regular maintenance of the DSL-800 simply involves cleaning the optical surfaces of the TRX, which are easily accessible due to the latched head and lid design.

The instrument is supplied with a stainless steel air purge body, which when connected to a high volume source of clean air, keeps the contaminated stack gas away for the lens surfaces.



Benefits

- US EPA PS-11 compliant.
- In situ measurement directly in exhaust gas flow.
- Measurement reading as mg/m³ (when calibrated against standard reference measurements).
- Intelligent analyser with optional DSCU operator interface.
- Rugged 316L stainless steel construction.
- Laser backscatter method requires no alignment and only a single access port on the stack.
- Plug and socket connectors for ease of installation.
- Automatic Zero and Span checking.

Specification



Class 3R visible laser beam. Avoid direct eye exposure.

Measurement Performance

Item	Parameter	Units	Min	Max	Comment
1	Stack Diameter	m	0.5	4	Internal diameter (three instrument variants)
2	Measurement Range	mg/m ³	0.0	1000	User selectable [1] (US EPA PS-11 Compliance 0-150mg/m ³)
3	Accuracy	%	-5	+5	Of measured value
		mg/m ³	-2	+2	Whichever is greater [1]
4	Resolution	mg/m ³	0.1	1	Display resolution (depends on absolute value)
5	Damping	s	1	600	Selectable
6	Drift with Temperature	%	-5	+5	Over the full operating temperature range
7	Operating Wavelength	nm	650	660	Laser (Class 3R)

Power & Air Requirements

8	Voltage	Vdc	+24		Optional 90-260 Vac PSU available
9	Voltage Tolerance	%	-15	+15	
10	Nominal Current Consumption	mA		500	
11	Power Up Current Consumption	mA		500	
12	Air Supply Volume	L/min	50	100	Supplied to the air-purge body
13	Air Supply Fitting				1" hosetail in the air-purge body

Interface Options

Item	Parameter	Units	Min	Max	Comment
14	Serial Comms				ModBus RTU via RS485 & External USB (TRX)
15	Analogue Output (one)	mA	0/2/4	20.0	Isolated. User configurable
16	Relay Contacts (two)	A	0	3	@30 Vdc. User configurable
17	Instrument Displays	Dust Reading (mg/m ³)			4 digit LED display
		Three Status Lights			Green-Power. Yellow-Fault. Blue-Maintenance

Physical

18	Ingress Protection		IP65		For external use
19	Ambient Operating Temperature	°C	-20	+50	Air temperature around the heads.
20	Operating Humidity	%		100	Air humidity around the heads.
21	Gas Temperature	°C		+400	
22	Materials	AISI/SAE 316L stainless steel			
23	Weight	kg		2.5	TRX head plus air purge body

Compliance & Design

24	Regulatory Compliance				2014/30/EU (Electromagnetic Radiation) 2014/35/EU (Low Voltage)
25	Design Life	Years	20		
26	MTBF	Hours	30,000		Replaceable Laser
27	Warranty	Months	24		Return to base warranty. Extensions available

[1] With default calibration settings

Path Length Options

The DSL-800 instrument is available in three path length variants

Short: for internal stack diameters of ~0.5 to 1.0m

Medium: for internal stack diameters of ~1.0 to 2.0m

Long: for internal stack diameters ~2.0 to 4.0m

For each variant there is a maximum and minimum distance allowed to the inner walls of the stack. These are illustrated below.

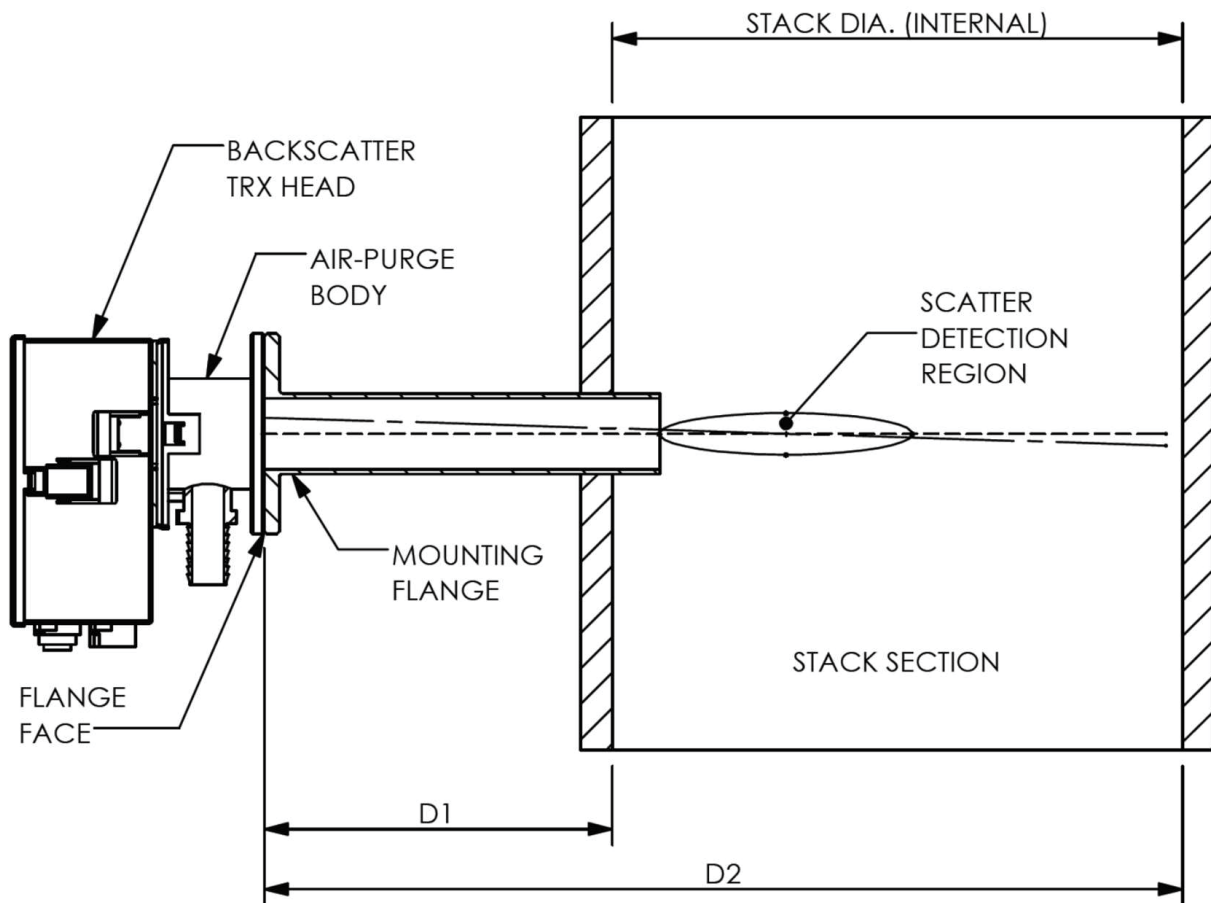

VARIANT	D1	D2
SHORT	≤0.25m	≥0.75m
MEDIUM	≤0.25m	≥1.25m
LONG	≤0.35m	≥2.35m

Configuration Options

With a DSCU

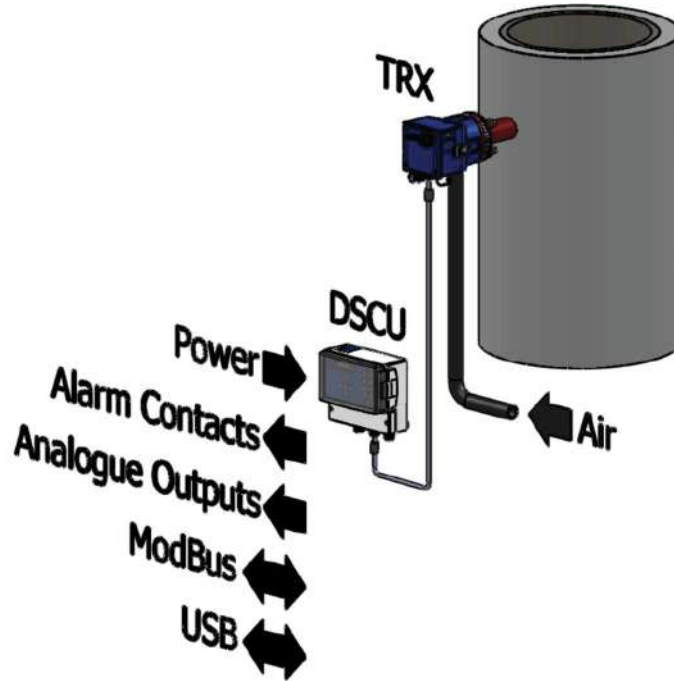

Without a DSCU

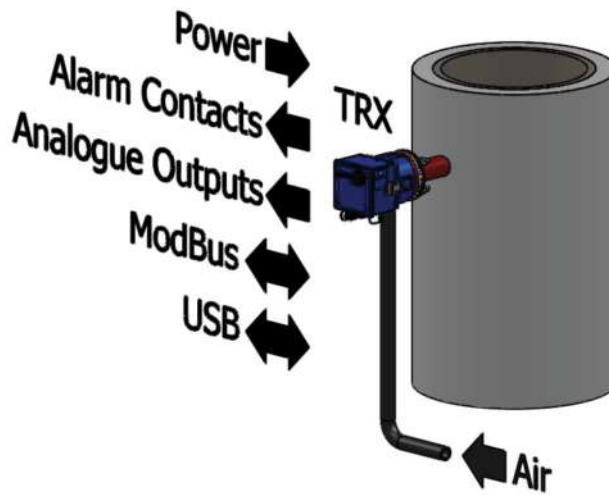

Dimensions

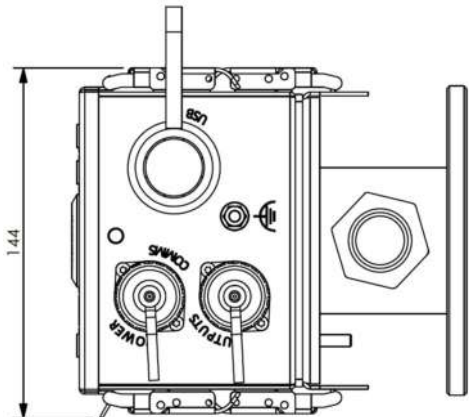
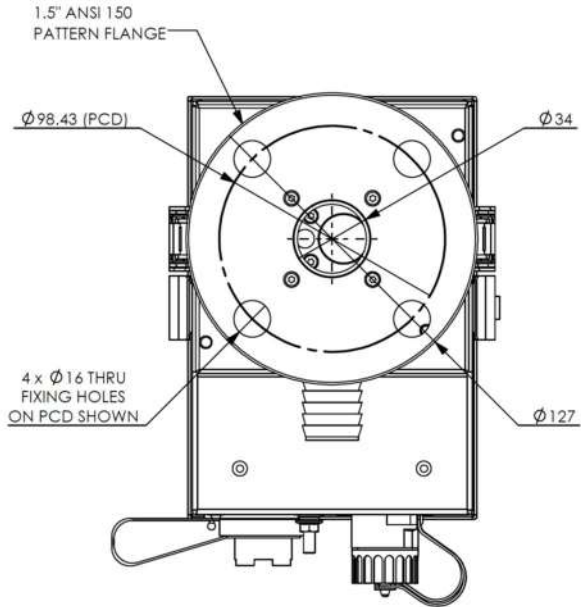
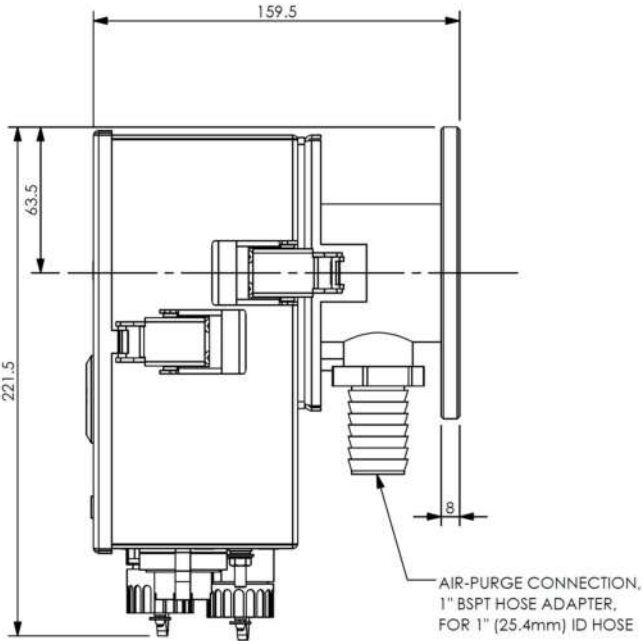

Options & Accessories

Description	Order Code	Notes
DSL-800 Instrument 	DSL-800-S DSL-800-M DSL-800-L	Laser back scatter instrument (short path, medium path or long path). With purge body.
Mounting Flange & Fixing Kit 	MTL-006	1.5" ANSI 150 flange pattern with 240mm long extension tube.
Fixing Kit for use with Stainless Steel Air Purge Body	ASY-227	Contains M14 x 100mm studding, flat washers, spring washers and M14 nuts.
Power / Comms Cable Assemblies	CBL-241 CBL-242 CBL-243	10m cable with connector 20m cable with connector 50m cable with connector
Outputs Cable Assemblies	CBL-238 CBL-239 CBL-240	10m cable with connector 20m cable with connector 50m cable with connector
Connector Bodies	DSL-8-CP	Connector Bodies for Power / Comms & Output.
Cable	CBL-099	7-core, screened LSHZ cable.
Boxed PSU	DSL-PSU-25	Multi AC input, 24Vdc output 25W, IP67 rated enclosure
Blower Kit 	DSL-BK40B-110-S	Blower kit for purge air; 110 Vac; single phase
	DSL-BK40B-230-S	Blower kit for purge air; 230 Vac; single phase
	DSL-BK40B-415-S	Blower kit for purge air; 415 Vac; three phase

Description	Order Code	Notes
<p>Compressed Air Kit</p> 	<p>DSL-CAK-1</p>	<p>For use with compressed air purge.</p> <p>Includes pressure regulator, in-line filters, and compressed air adaptors for the purge body.</p>
<p>DSCU</p> 	<p>DSL-DSCU-1 DSL-DSCU-4 DSL-DSCU-8</p>	<p>1 analogue output and relay 4 analogue outputs and relays 8 analogue outputs and relays</p>
<p>Audit Filter Kit</p> 	<p>DSL-8-AFK</p>	<p>Contains a calibration head and three audit filters.</p>

Note that the actual part may differ from the above representative pictures.

