

USER MANUAL

HiVol 3000

High Volume
Air Sampler

Version 1.8



acoem.com



Ecotech Pty Ltd is now part of the Acoem Group and as such, the branding of our instruments & software has also changed to 'Acoem'.

Over time we will be updating the content of all documents to reflect the Acoem branding convention.

In the interim, please note that while the cover of this document features Acoem branding, information contained within its pages still utilises the original 'Ecotech' name.

Table of Contents

Table of Contents	3
List of Figures	5
List of Tables.....	6
Manufacturer’s Statement	7
Notice	7
Warranty.....	8
Service and Repairs.....	9
Service Guidelines	9
CE Mark Declaration of Conformity.....	10
Safety Requirements	10
Equipment Rating.....	10
Environmental Conditions.....	10
Claims for Damaged Shipments and Shipping Discrepancies	11
Damaged Shipments	11
Shipping Discrepancies.....	11
Contact Details	11
Internationally Recognised Symbols on Ecotech Equipment.....	12
Manual Revision History.....	13
1 Introduction.....	15
1.1 Description	15
1.2 Features	15
1.3 Specifications	16
1.3.1 Flow Control	16
1.3.2 Temperature/Pressure Measurement.....	16
1.3.3 Power Supply	17
1.3.4 Operating Conditions.....	17
1.3.5 Physical Features	17
1.4 Nomenclature	18
1.5 Background/Theory.....	18
1.5.1 Particulate Monitoring Background.....	18
1.5.2 Ecotech HiVol Background.....	19
1.5.3 Sampling Method	20
1.5.4 Particulate Matter Standards	22
1.6 Instrument Description	23
1.6.1 Sampler Housing.....	23
1.6.2 Blower Motor	23
1.6.3 Flow Path	23
1.6.4 Flow Sensor.....	24
1.6.5 Flow Control	24
1.6.6 Electronics Enclosure	25
1.6.7 Control Panel	25
1.6.8 Power Inlet	25
1.6.9 Filter Cassette	25
1.6.10 Temperature Sensor	25
2. Installation	27

2.1	Initial Check	27
2.2	Assembly.....	28
2.2.1	Inlet Hood – Assembly & Adjustment	28
2.2.2	PM ₁₀ or PM _{2.5} Size Selective Inlet (SSI) Assembly (Option).....	30
2.2.3	Assembling the Muffler	30
2.2.4	Connecting a Wind sensor or Rain-gauge	31
2.2.5	Connecting an External Trigger for Remote Activation	32
2.3	Mounting/Siting.....	33
2.3.1	Siting	33
2.3.2	Mounting.....	34
2.4	Instrument Set-up.....	35
2.4.1	Power Connections	35
2.4.2	Exhaust Connections	36
2.4.3	Muffler for Noise Reduction.....	36
2.4.4	Filter Selection for TSP Sampling.....	36
2.4.5	Filter Selection for PM ₁₀ and PM _{2.5} Sampling	37
2.4.6	Filter Preparation	37
2.4.7	Installation of Sample Filter	38
2.5	Transporting/Storage.....	39
3.	Operation	41
3.1	Warm-up.....	41
3.2	General Operational Information	41
3.2.1	HiVol Sampling Protocol.....	42
3.2.2	Menu Operation.....	44
3.2.3	Changing Menu Settings	44
3.3	Main Screen	45
3.4	Sampling	46
3.4.1	Pre-Sampling	46
3.4.2	Beginning Sampling.....	47
3.4.3	Conclusion of the Sampling.....	48
3.4.4	Recording Sample Corrected Volume & Clearing Logger	48
3.5	Menus & Screens	49
3.5.1	Status Screen.....	50
3.5.2	Setup Menu	51
3.5.3	Manual Menu.....	58
3.5.4	Calibration Menu	59
3.6	Flow Rate Calibration.....	59
3.6.1	Flow Rate Calibration – Temperature and Pressure Corrections	60
3.6.2	Using the Calibration Chart for Top Loading Orifice Plate.....	61
3.6.3	Flow Rate Calibration Procedure.....	63
3.7	Calibration of Temperature and Pressure Sensors	64
3.8	Temperature Sensor Calibration.....	64
3.9	Barometric Pressure Sensor Calibration	65
4.	Downloading Data.....	69
4.1	HiVol Connection	69
4.2	Using Downloader Software	69
4.3	Communicating with the HiVol (Alternative Method)	71
4.4	Calculations	Error! Bookmark not defined.

4.4.1	Sample Volume	Error! Bookmark not defined.
4.4.2	Mass Concentration Calculation	Error! Bookmark not defined.
5.	Maintenance	73
5.1	Maintenance Tools	73
5.2	Maintenance Schedule	74
5.3	Maintenance Procedures	74
5.3.1	General Sampler Component Check	74
5.3.2	Automatic Flow	74
5.3.3	Cassette	74
5.3.4	Size Selective Inlet	74
5.3.5	Flow Sensor Adjustment	76
5.3.6	Flow Sensor Replacement	77
5.3.7	Hidden Menu	78
Appendix A.	Noise Test	81
Appendix B.	References	83
5.4	Australian Standards	83
5.5	US EPA Standards	83
5.6	British Standards	83
Appendix C.	Accessories	85
Appendix D.	Field Operation Checklist	87
Appendix E.	High Volume Air Sampler Filter Papers Custody Record	89
Appendix F.	HiVol Field Calibration Record	Error! Bookmark not defined.

List of Figures

Figure 1 – Inlet hoods for HiVol	21
Figure 2 – Cross-section of PM ₁₀ size selective inlet hood	21
Figure 3 – Flow path schematic	24
Figure 4 – HiVol 3000 components layout	28
Figure 5 – HiVol hood attachment	29
Figure 6 – Attaching the support stay	29
Figure 7 – Installing the optional muffler	31
Figure 8 – External trigger output	32
Figure 9 – Site selection guidelines	34
Figure 10 – HiVol power connection	35
Figure 11 – Installing the loaded filter cassette	38
Figure 12 – Power switch location	41
Figure 13 – HiVol 3000 control panel	41
Figure 14 – Menu structure	49
Figure 15 – Conditional sampling and wind direction sensor set-up	55
Figure 16 – Calibration set-up	60
Figure 17 – HiVol serial port (RS-232C)	71
Figure 18 – Application of grease	76
Figure 19 – Rear panel	77

Figure 20 – Flow sensor 77
Figure 21 – Pipe clamp 78

List of Tables

Table 1 – Manual revision history..... 13
Table 2 – Main screen with motor on..... 45
Table 3 – Main screen with motor off 45
Table 4 – Main menu 49
Table 5 – Data displayed..... 61
Table 6 – Standard temperature and pressure..... **Error! Bookmark not defined.**
Table 7 – Maintenance schedule 74
Table 8 – SSI cleaning schedule 75
Table 9 – TSP concentration and cleaning intervals 75
Table 10 – Flow voltage values 76
Table 11 – Hidden menu..... 79
Table 12 – Accessories..... 85

Manufacturer's Statement

Thank you for selecting the Ecotech HiVol 3000 High Volume Air sampler. The HiVol 3000 is a High Volume Air Sampler with innovative design features, designed primarily for particulate sampling. By following the guidelines contained in this manual and with the implementation of a good quality-assurance program, the user can obtain accurate and reliable data.

The HiVol 3000 is the next generation of samplers incorporating true volumetric flow control, data logging and advanced programming functions. Reliable electronic air flow sensing techniques coupled with a proven induction motor ensures a product of exceptional quality capable of producing years of maintenance free operation.

This User Manual provides a complete product description including operating instructions, calibration, and maintenance requirements for particulate sampling techniques.

Reference should also be made to the relevant standards, which should be used in conjunction with this manual. Some relevant standards are listed in the References section of this manual.

If, after reading this manual you have any questions or you are still unsure or unclear on any part of the HiVol 3000 then please contact Ecotech.



Please help the environment and recycle the pages of this manual when finished using it.

Notice

The information contained in this manual is subject to change without notice. Ecotech reserves the right to make changes to equipment construction, design, specifications and/or procedures without notice.

Copyright © 2013. All rights reserved. Reproduction of this manual, in any form, is prohibited without the written consent of Ecotech Pty Ltd.



CAUTION

Hazardous voltages exist behind the sampler control panel and within the sampler housing. Ensure the control panel and front and rear enclosure panels are always in place when the sampler is connected to the mains. The front doors should be closed when the sampler is left unattended. Ensure the power cord, plugs and sockets are maintained in a safe working condition.

Ecotech recommends the use of Earth-Leakage Protection Circuit Breakers (ELCB) on the power supply to the HiVol. If operating from a generator, power conditioner, isolation transformer, or other floating supply, refer to Section 2.4 on Instrument setup, as some important modifications are required.

Safety Requirements

To reduce the risk of personal injury caused by electrical shock, follow all safety notices and warnings in this documentation.

If the equipment is used for purposes not specified by Ecotech, the protection provided by this equipment may be impaired.

Replacement of any part should only be carried out by qualified personnel, only using parts specified by Ecotech. Always disconnect power source before removing or replacing any components.

Warranty

This product has been manufactured in an ISO 9001/ISO 14001 facility with care and attention to quality.

The product is subject to a 12-month warranty on parts and labour from date of shipment. The warranty period commences when the product is shipped from the factory. Lamps, fuses, batteries and consumable items are not covered by this warranty.

Each air sampler is subjected to a rigorous testing procedure prior to despatch and will be accompanied with a parameter list and a multipoint calibration check thereby enabling the sampler to be installed and ready for use without any further testing.

Service and Repairs

Our qualified and experienced technicians are available to provide fast and friendly service between the hours of 8:30am – 5:00pm AEST Monday to Friday. You are welcome to speak to a service technician regarding any questions you have about your HiVol.

Service Guidelines

In the first instance, please call or email us if you are experiencing any problems or issues with your air sampler.

If you are within Australia or New Zealand please contact our service response centre via email on service@ecotech.com.au or call +61 (0)3 9730 7800

If outside of Australia and New Zealand please email our international support department at intsupport@ecotech.com or call +613 9730 7800

If we cannot resolve the problem through technical support, please email the following information:

- Name and phone number.
- Company name.
- Shipping address.
- Quantity of items being returned.
- Model number/s or a description of each item.
- Serial number/s of each item (if applicable).
- A description of the problem.
- Original sales order or invoice number related to the equipment.

When you email us we will assign a Return Material Authorisation (RMA) number to your shipment and initiate the necessary paperwork to process your equipment within 48 hours.

Please include this RMA number when you return equipment, preferably both inside and outside the shipping packaging. This will ensure you receive prompt service.

CE Mark Declaration of Conformity

This section is applicable only to E040020 (CE approved version of HiVol). Ecotech P/L certifies that this product operates in compliance with the EC Directive 89/336/EEC in reference to electrical emissions and immunity. Specifically the equipment meets the requirements of EN61000-6-3 for RF Emissions and EN 61000-6-1 for RF immunity.

In addition, this product has been tested in compliance with the EC Directive 73/23/EEC in reference to electrical safety and meets the requirements of EN 61010-1. The equipment must be operated as per Ecotech directions as specified in this manual.

Safety Requirements

To reduce risk of personal injury caused by electrical shock, follow all safety notices and warnings in this documentation. This equipment should always be used with a protective earth installed.

The HiVol 3000 is compliant with the requirements of EN 61010-1, Safety Requirements for Equipment for Measurement, Control, and Laboratory Use. If the equipment is used for purposes not specified by the manufacturer, the protection provided by this equipment may be impaired.

Replacement of any part should only be carried out by qualified personnel, only using parts specified by the manufacturer. Always disconnect power source before removing or replacing any components.

Equipment Rating

- 240V~ ±10% (not applicable to 110V version)
- 50/60 Hz
- 1500 VA max
- All wiring must be in accordance with local norms and be carried out by experienced personnel.
- IP56 rated
- Fuse: 8 Amp T250

Environmental Conditions

Relative humidity	10% to 100% non-condensing
Temperature	0 to 45 °C
Pollution degree	2
Installation category	II
Maximum altitude	2000m



CAUTION

Never operate this equipment around flammable liquids or vapours, as this could cause a safety hazard.

Claims for Damaged Shipments and Shipping Discrepancies

Damaged Shipments

Inspect all instruments thoroughly on receipt. Check materials in the container/s against the enclosed packing list. If the contents are damaged and/or the instrument fails to operate properly, notify the carrier and Ecotech immediately.

The following documents are necessary to support claims:

- Original freight bill and bill of lading.
- Original invoice or photocopy of original invoice.
- Copy of packing list.
- Photographs of damaged equipment and container.

You may want to keep a copy of these documents for your records.

Please refer to the instrument name, model number, serial number, sales order number, and your purchase order number on all claims.

You should also:

- Contact your freight forwarder for an insurance claim.
- Retain packing material for insurance inspection.

Shipping Discrepancies

Check all packages against the packing list immediately on receipt. If a shortage or other discrepancy is found, notify the carrier and Ecotech immediately. We will not be responsible for shortages against the packing list unless they are reported promptly (within 7 days).

Contact Details

Head Office

1492 Ferntree Gully Road, Knoxfield VIC Australia 3180

Phone: +61 (0)3 9730 7800 Fax: +61 (0)3 9730 7899









Email: info@ecotech.com

Service: service@ecotech.com.au

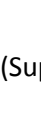
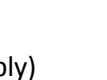
International Support: intsupport@ecotech.com

www.ecotech.com

Internationally Recognised Symbols on Ecotech Equipment

	On (Supply)	IEC 417, No. 5007
	Off (Supply)	IEC 417, No. 5008
	Electrical fuse	IEC 60417-5016
	Earth (ground) terminal	IEC 60417-5017
	Protective conductor terminal	IEC 60417-5017
	Equipotentiality	IEC 60417-5021
	Alternating current	IEC 60417-5032
	Caution, hot surface	IEC 60417-5041
	Caution, risk of danger. Refer to accompanying documents	ISO 7000-0434
	Caution, risk of electric shock	ISO 3864-5036

Manual Revision History

Manual PN: M010049
 Current revision: 1.8
 Date released: 9 August 2013
 Description: User Manual for the HiVol 3000 High Volume Air Sampler

This manual is the full user manual for the HiVol 3000 High Volume Air Sampler. This manual contains all relevant information on theory, specifications, installation, operation, maintenance and calibration. Any information that cannot be found within this manual can be obtained by contacting Ecotech.

Table 1 – Manual revision history

Edition	Date	Summary	Affected Pages
1.0	October 2002	Initial release	All
1.1	November 2003	General Updates	All
1.2	June 2005	Trigger input added PM ₁₀ Field checklist added Updates relating to U.S. EPA Reference Method requirements	4-4 to 4-5, 6-13 to 6-15 9-2 All
1.3	September 2006	U.S. EPA reference method section (1.5) added.	1-7
1.4	September 2008	New Contact details added and manual design change	All
1.5	December 2008	Info on new flow sensor	11, 68-70
1.6	May 2009	Major blockage feature added	32, 49
1.7	November 2009	Added picture of greasing SSI Removed information on old temp sensor Updated temp sensor calibration	31 64
1.8	August 2013	Formatting revised	All

This page is intentionally blank.

1 Introduction

1.1 Description

The HiVol 3000 Particulate Sampler provides a flexible platform for sampling of PM₁₀, PM_{2.5} or TSP particulate and for monitoring basic meteorological parameters. The sampler is microprocessor based and features internal data logging of flow and meteorological parameters.

The HiVol 3000 is designed to operate from a mains power supply. Refer to Section 2 and 2.4.1 for important power connection details.

The HiVol 3000 incorporates ambient temperature and pressure sensors, which are used to automatically maintain a constant volumetric flow-rate of typically 67.8 m³/h through a rectangular filter mounted in a cassette-style filter holder.

The HiVol 3000 includes the facility to monitor wind speed and direction, using an optional external wind sensor. Wind speed and direction data are averaged and stored in internal memory, and may be used as triggers for conditional sampling.

The HiVol 3000 also has the ability to be remotely triggered by an optional external sensor or instrument. The trigger signal can be used for remote control or conditional sampling.

The HiVol 3000 also incorporates a time clock and programmable timer enabling multiple times based sampling programs to be configured.

The HiVol 3000 internal data logger stores time based data averages at user selectable intervals. The data includes date and time stamp, flow-rate, total sample volume, average temperature, barometric pressure, and either wind speed and wind direction, or rain-fall information, if external wind/rain sensors are installed. Data stored in the HiVol may be downloaded via the RS-232C serial port.

The HiVol 3000 is extremely quiet allowing it to be used in residential sampling locations to assess human exposure to particulate matter (PM), and is housed in a weatherproof enclosure for outdoor sampling in a range of environments. Refer to Appendix A for typical noise levels.

1.2 Features

- Active volumetric flow control. Advanced flow control system which gives true volumetric flow control using temperature and pressure sensors and mass flow rate sensor.
- Conditional sampling based on wind speed and direction.
- Interchangeable PM₁₀, PM_{2.5} and TSP sampling inlets are available as options.
- Multiple time based sampling programs.
- Internal data logging.
- Sampler setup via four-line LCD display and keypad.
- Simple programming of sampling periods, including daily and weekly programs, with 1-in-X day sampling capability built in.

- Ultra-efficient, long life blower motor.
- Low noise operation suits applications near residential areas.
- Low power consumption.
- Automatic supply voltage monitoring and shut-down when voltage is out of range, preventing damage to instrument.
- No rotating/wearing components other than the blower motor.
- Durable marine quality weather proof anodised aluminium cabinet.
- Data logging capacity: 10min average 23.5hrs*
- 1hr average: 5.8 days*
- 3hr average : 17.6 days*

*Includes Time, Date, Flow, Temperature, Pressure, WS & WD

1.3 Specifications

1.3.1 Flow Control

Volumetric Flow-rate Range

45-96m³/h

Flow Accuracy

Better than ± 1 m³/h

Flow Repeatability

1.0% of reading

Vacuum Capability

140 mBar (max)

1.3.2 Temperature/Pressure Measurement

Temperature Range

0-45°C

Temperature Accuracy

± 1 °C

Barometric Range

600-900 mmHg (Torr)

(800-1200 hPa)

Baro. Pressure Accuracy

±4 mm Hg (Torr)

1.3.3 Power Supply

Voltage & Frequency

240VAC±10%, 50/60Hz, single phase 1500VA MAX

110VAC ±10%, 50/60Hz, single phase 1500VA MAX

Power Consumption

1500VA max

Depending on filter loading and flow rate

Power Connector

10A weatherproof inlet

(Australian pin configuration)

(Weatherproof coupling supplied)

IP56 with coupling fitted



CAUTION

A qualified electrical contractor must fit the wirable socket to an appropriate supply cord. Refer to **2.4.1** for more details.

1.3.4 Operating Conditions

Ambient Temperature/Humidity Range

0-45°C

RH 10% to 100% non-condensing

Note: Avoid corrosive, salty or excessively humid environments where possible.

1.3.5 Physical Features

Case Dimensions

380x380x1200mm (WxDxH) plus inlet

Inlet Materials

Anodised aluminium and stainless steel

Interchangeable Inlets

TSP, PM₁₀ and PM_{2.5} (options)

Cut-point

PM₁₀ and PM_{2.5} 50% cut-point at 67.8m³/h volumetric flow-rate

Filter Holder Material

Anodised aluminium and stainless steel

Filter Element

250x200mm rectangular element (various materials and types are available)

Weight

45 kg plus inlet

1.4 Nomenclature

- SSI:** Size Selective Inlet, used to sample particulates of a given Equivalent Aerodynamic Diameter (PM₁₀, PM_{2.5}).
- TSP:** The TSP (Total Suspended Particulate) includes all suspended particulate matter.
- PM₁₀:** The PM₁₀ includes all particulates of an Equivalent Aerodynamic Diameter (EAD) of 10 microns or less.
- PM_{2.5}:** The PM_{2.5} includes all particulates of an Equivalent Aerodynamic Diameter (EAD) of 2.5 microns or less.
-

1.5 Background/Theory

1.5.1 Particulate Monitoring – Background

During the late 1970's the US EPA began to develop health-based ambient air quality standards for airborne particles.

The US EPA concluded that particles capable of penetration through the upper respiratory tract could deposit in the tracheobronchial and alveolar regions of the human body and could have adverse health effects.

Researchers in the field identified that the particle size range capable of deposition within the human thoracic region was significant for particles less than 10 µm in diameter (PM₁₀).

In 1987 the US EPA promulgated a PM₁₀ size-specific air quality standard for ambient particulate matter for the protection of human health.

In 1997 the US EPA revised their national ambient air quality standards again to include PM_{2.5}. The PM_{2.5} standard now replaces TSP and PM₁₀ as the primary ambient air particulate pollution parameter in the United States.

Monitoring of atmospheric air quality in the United States for compliance to the National Ambient Air Quality Standards (specified in US 40 CFR Part 50) requires the use of either reference or equivalent methods.

For PM₁₀ the reference method is contained in the Code of Federal Regulations - Appendix J - Reference Method for the Determination of Particulate Matter as PM₁₀ in the Atmosphere.

1.5.2 Ecotech HiVol Background

High volume air samplers are used to collect samples of air-borne matter for subsequent analysis. Generally, high volume air sampling is a technique that employs a gravimetric method for the determination of suspended particulate matter in the atmosphere. The term 'gravimetric' implies a weight measurement.

The technique of high volume air sampling developed in the United States during the 1940's. Early "HiVols" (generic term for High Volume Air Samplers) were comprised of modified household vacuum cleaners with 100 mm diameter filters.

During the 1950's the design was altered to incorporate the use of 200 x 250 mm filters to permit continuous 24 hour sampling.

Until the 1980's the HiVol sampler was used solely to collect data on total suspended particulate matter (TSP). With the introduction of primary health-based particle standards during the 1980's many HiVol samplers were retro-fitted with PM₁₀ Size Selective Inlets (SSI) to capture particulate matter less than 10 µm (micro-metre or micron) in diameter.

The technique is known as High Volume Size Selective Inlet PM₁₀ sampling, and monitoring is aimed at providing information on particles capable of penetrating to the thoracic region of the human body. More recently, PM_{2.5} concentration has been linked to adverse health effects. A PM_{2.5} Size Selective Inlet (SSI) is used to capture particulate matter less than 2.5 µm in diameter.

The Ecotech HiVol may be fitted with a TSP inlet, PM₁₀ or PM_{2.5} SSI hoods. The inlets are easily interchanged if required. The inlet hoods can be easily identified - the TSP inlet is shaped like a pyramid and the SSI type is cylindrical in shape. The SSI will be identified as PM₁₀ or PM_{2.5}.

The airborne suspended particles that pass through the inlet are collected on a pre-weighed filter, during a pre-determined sampling period that is programmed into the HiVol by the operator. The filter collects the airborne particles for subsequent analysis. The HiVol controls the flow-rate and records the sampling duration and volume of air that has been sampled.

After the sampling period is complete, the filter is removed and re-weighed to determine the concentration and/or composition of suspended particulate matter. Concentration results are typically expressed in micrograms per cubic metre (µg/m³) of air sampled at Standard Temperature and Pressure (STP) conditions.

Acceptable levels have been established to govern the amount of airborne particulate of a particular size and composition that may pose a health hazard to humans.

1.5.3 Sampling Method

The HiVol 3000 is designed primarily as a particulate sampler. The HiVol pump and flow controller draws a constant flow rate of ambient air through a specially prepared filter.

The air-borne suspended particles are collected on the pre-weighed filter over a pre-determined period. After sampling the filter is removed and re-weighed to determine the concentration of particulate matter (TSP, PM₁₀ or PM_{2.5}).

The total volume of air can be calculated from the flow-rate multiplied by the sampling time. Results are expressed as micrograms per cubic metre of air sampled ($\mu\text{g}/\text{m}^3$), calculated at standard (or reference) conditions of temperature and pressure (STP).

The display on the control panel of the HiVol 3000 indicates the volumetric flow rate of air, and computes the sample volume corrected to STP conditions which means that no additional calculations are required during normal operation. This gives the HiVol 3000 an advantage over other hi-vol types that control mass flow rate. Volumetric flow control ensures that the size selective inlet is always operating at the desired flow rate. Automatic correction to reference conditions eliminates average seasonal temperature and pressure corrections. This eliminates two sources of error that could otherwise introduce significant inaccuracies, and additional calculations.

The STP Reference conditions can be programmed into the HiVol. The Australian/European Standard Temperature and Pressure (reference) conditions are 0°C (273.15K) and 101.3 kPa. In the United States, reference conditions are 25°C (298.15K) and 101.3 kPa. The HiVol must have the correct STP Reference conditions entered in the Setup menu, in order to report the "Corrected Sample Volume" to the appropriate reference conditions.

The HiVol 3000 can sample TSP or can utilise optional SSI to restrict the sampled particulate to being that of a designated size or smaller.

1.5.3.1 Total Suspended Particulate (TSP) Sampling

TSP is the suspended particle fraction in the atmosphere that includes particle sizes up to around 50 μm diameter. Due to the simple inlet shape of the TSP sampler the particle cut-point is not precise and may be influenced by wind speed, wind direction and sampler flow-rates. The TSP inlet will prevent unusually large particles and insects being collected on the filter.

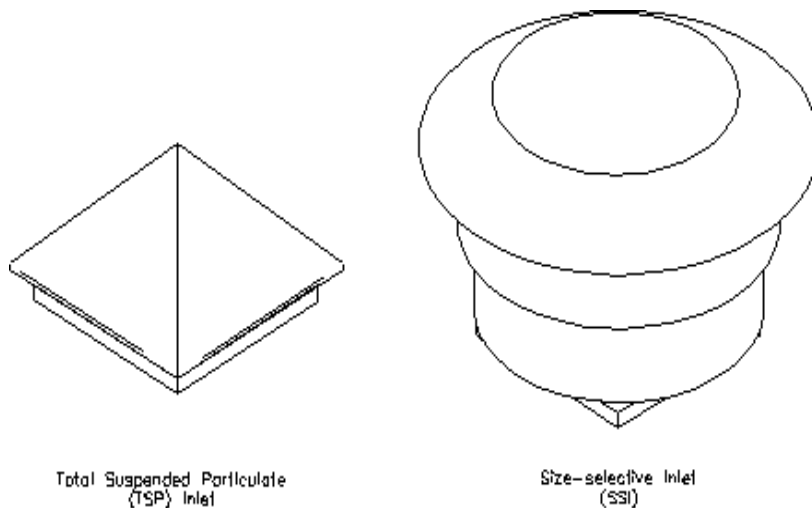

Figure 1 – Inlet hoods for HiVol

1.5.3.2 Size Selective Inlets: Sampling at PM₁₀ and PM_{2.5}

Ambient air is drawn into the size-selective inlet at a constant volumetric flow-rate of 1.13m³/min (67.8m³/h) for both the PM₁₀ and PM_{2.5} inlets. To achieve this, the HiVol 3000 uses a true volumetric flow-rate controller (via temperature and pressure compensation of a mass flow sensor).

The size-selective inlet is of the impactor type. The particles in the air are accelerated through multiple acceleration nozzles. Particles larger than the specified 2.5 or 10 µm cut-point gain sufficient momentum to cause impaction onto a greased collection shim where they are trapped. (The collection shim should be periodically cleaned and re-greased). The PM₁₀ or PM_{2.5} particles, however, are smaller and having less momentum, remain entrained in the air-flow and pass to the filter, where they are collected.

The SSI cut-point is affected by airstream velocity /flow-rate, acceleration nozzle diameter, and particle density, composition and shape.

The symmetrical design of the SSI overcomes the effect of wind direction and the inlet design makes the collection efficiency independent of wind speeds up to 36 kilometres per hour.

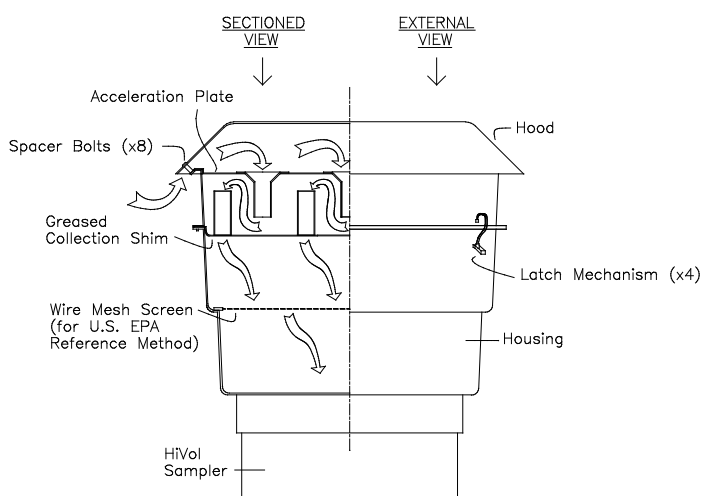

Figure 2 – Cross-section of PM₁₀ size selective inlet hood

1.5.4 Particulate Matter Standards

US EPA Ambient Particulate Standards

US EPA primary standards for PM₁₀ are:

- 24 hour average 150µg/std m³
- Annual average 50µg/std m³

US EPA primary standards for PM_{2.5} are:

- 24 hour average 35µg/std m³ (24h average, 98th percentile, averaged over 3 years)
- Annual average 15µg/std m³ (annual arithmetic mean, averaged over 3 years)

US EPA reference conditions are:

- Standard temperature defined as 298K (25°C)
- Standard pressure defined as 101.3 kPa (760mm Hg)

The total volume of air sampled is determined by the sampler from the measured flow rate at actual ambient temperature and pressure, and the sampling run-time.

Note: The US EPA reference method for PM_{2.5} is the method specified in the US EPA Code of Federal Regulations 40 Part 50 Appendix L, Federal Reference Method for the Determination of Fine Particles Matter as PM_{2.5} in the Atmosphere.

Australian Ambient Particulate Standards

The Australian National Environmental Protection Council has established the following objectives for Particles as PM₁₀:

24 hour average

- Maximum concentration: 50µg/std m³
- Maximum allowable exceedances: 5 days per year

Australian reference conditions

- Standard temperature defined as 273K (0°C)
- Standard pressure defined as 101.3 kPa (760mm Hg)

US EPA Reference Method Designation

The HiVol must be configured in the following arrangement to meet the US EPA designated reference method:

- PM₁₀ size selective inlet installed and flow rate set to 67.8 m³/hour (1.13m³/min)

Any configuration different to this is not covered under the designation.

1.6 Instrument Description

1.6.1 Sampler Housing

The HiVol housing and inlet hood are constructed in aluminium, providing a light-weight and non-corrosive housing, even in the event of exposed metalwork. The enclosure comprises three main parts: the inlet hood, the outer enclosure and the electronic enclosure (housed inside the outer enclosure.) The HiVol 3000 is constructed from marine grade anodised aluminium, which provides good durability in most environments.

Two front doors are fitted. The lower door cannot be opened with the upper door in the closed position. A keyed lock is fitted to the upper door. The lower door is also retained by a sliding latch, which engages a slot in the side panel. Slide to the left to retain the door in the upright position.

1.6.2 Blower Motor

The blower is driven by a squirrel-cage induction motor, and is constructed of cast aluminium achieving a weight saving and also providing corrosion resistance. Silencers are mounted on both the inlet and outlet, which reduces noise levels considerably. (Further noise reduction can be achieved using the optional exhaust muffler – refer to Section 2.4.3). The blower is equipped with sealed-groove ball bearings, which do not need lubrication. The grease filling is sufficient for the whole service life of the bearings.

1.6.3 Flow Path

The inlet funnel for the sampler is constructed of fibre glass, which provides a gradual change in flow geometry ensuring an even pressure gradient and avoiding flow resistance and noise. The design also enables equal flow-rates through the whole cross section of the filter. Following the funnel, a joining sleeve is provided to allow for easy access to the flow sensor and to aid in removal of the blower motor. All tubing is PVC. Fittings are available for connection of an external exhaust duct.

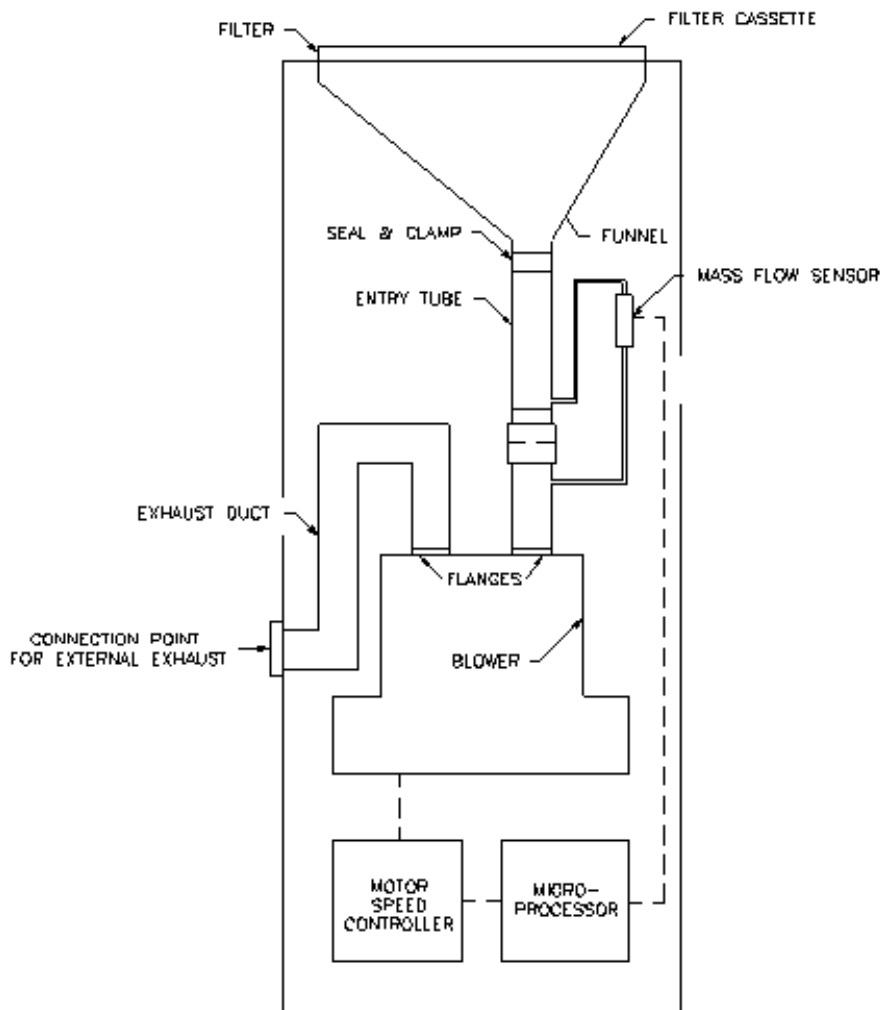

Figure 3 – Flow path schematic

1.6.4 Flow Sensor

The flow sensor is a precision mass flow sensor - which “reads” the flow-rate and converts it to an electronic signal. This is connected to the electronics enclosure, from where the flow sensor signal performs two functions. One is to indicate the current flow-rate of air, via the LCD display, and the other is to provide feedback to the flow control circuit.

The HiVol Model 3000 uses a mass flow sensor located within a parallel by-pass tubing. An orifice is used to control the amount of flow through the by-pass and then the mass flow sensor is used to calculate the total flow in the instrument. The device has been designed to be easily removed and replaced and must be serviced by Ecotech.

1.6.5 Flow Control

Flow control is achieved by a Variable Speed Drive (VSD) (sometimes called an inverter or variable frequency drive.) The drive controls the speed of the blower motor based on a signal from the microprocessor. The drive automatically corrects the flow rate of air so that when the filter becomes loaded with particulate matter, the flow-rate remains constant. The time required to reach the correct flow is typically less than 15 seconds.

At initial start-up, the HiVol may take up to a minute to reach the correct flow rate.

1.6.6 Electronics Enclosure

The instrument electronics enclosure houses most of the electronic components. The LCD display, controller, and variable speed drive are located in this enclosure which has a weatherproof seal. This box is sealed and may only be accessed by qualified service personnel.



CAUTION

Hazardous voltages exist within the enclosure. Access by skilled service personnel only.

1.6.7 Control Panel

The control panel is part of the instrument electronics enclosure and houses, the digital display, keypad and Serial port.

The panel is coated in a scratch-resistant splash-proof plastic, which can be cleaned with mild detergent and water.

1.6.8 Power Inlet

Refer to Section 2.4.1 for important Power Connection information.

The power inlet to the sampler is via a 10 Amp, single phase industrial duty inlet. The inlet has a waterproof rating of IP65. One inlet socket is provided with the sampler and this should be used with the orange weatherproof coupling. The power on/off switch is located beneath the electronics enclosure, near the power inlet module. The electrical circuit should be protected by a circuit-breaker.

1.6.9 Filter Cassette

The filter cassette is comprised of a mesh screen base, and top covering frame. With the filter correctly installed in the cassette, sample air will pass only through the filter to enter the sampler.

Use of the cassette allows for filter changes during adverse weather. The filter cassette can be removed to a protected location, the exposed filter removed, a new filter installed and the loaded cassette can then be returned to the sampling site for fitting to the sampler.

1.6.10 Temperature Sensor

The HiVol 3000 temperature sensor is located within the chassis and plugs directly into the entry tube. The temperature sensor measures the temperature of the gas flow, using them for volumetric flow control.

This page is intentionally blank.

2. Installation

2.1 Initial Check

1. Upon receipt of the sampler, check the packing slip to ensure all items have been delivered, and inspect the sampler for damage during transit. The inlet hood (TSP inlet or Size Selective Inlet) is packaged separately so the complete sampler will generally consist of two containers.

Notify both the shipping company and Ecotech immediately if damage has occurred. Retain the packaging materials as the container has been specially designed to protect the sampler during transit and will be needed should service be required in the future.

2. Prior to shipping the HiVol to the monitoring site, it is recommended that the equipment is completely assembled and field staff are familiarised with its operation including field calibration, filter changing and maintenance.
3. The HiVol can be tested before being fully installed on site. To begin with, check the funnel assembly on the upper surface of the sampler for packing material or other foreign objects. Remove the filter cassette from the packaging and place the filter cassette within the cassette locaters on top of the sampler.
4. Ensure the exhaust outlet on the side of the sampler is not obstructed and connect the sampler to the power supply, making sure that the supply voltage and frequency are correct for the sampler.
5. Turn the sampler on and observe the display. If the blower operates and the display shows a flow rate, the unit will most probably be ready for initial calibration.

Note: The sampler should not be run unattended without being correctly mounted. Refer to Section 2.3.2 for mounting details.

2.2 Assembly

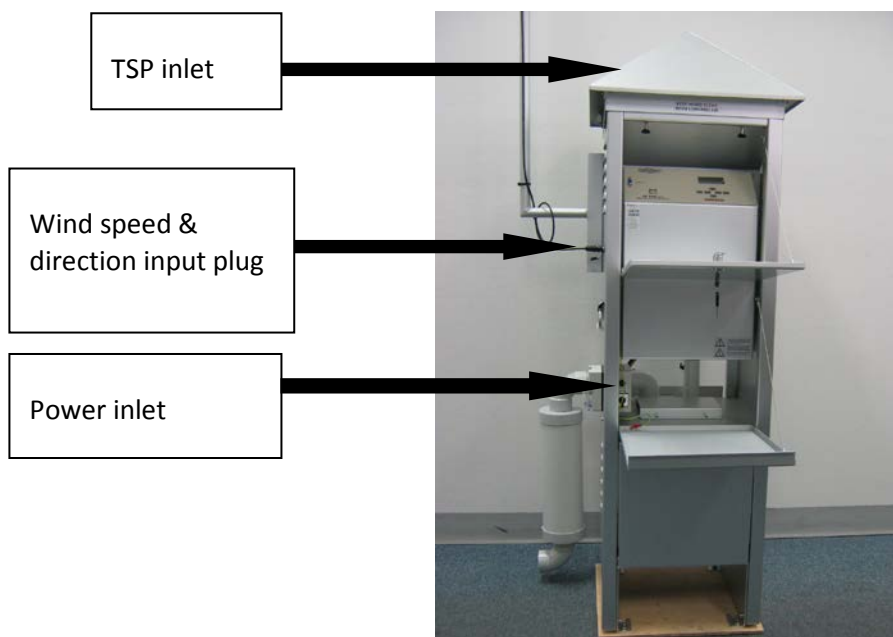

Figure 4 – HiVol 3000 components layout

2.2.1 Inlet Hood – Assembly & Adjustment

The inlet hood can either be the pyramid shaped TSP type, or the larger circular SSI type – refer to Figure 1. The inlet hood also serves to retain the filter cassette in position and to clamp the cassette to the sampler to eliminate leaks.

Note: The HiVol 3000 is compatible with inlets from the previous Ecotech model 2000 High Volume Air Sampler. Inlets are interchangeable without modification to the sampler.

1. Remove the two bolts and washers, located at the top of the back legs of the sampler, which will act as the pivot points for the inlet hood.
2. Remove the nut and bolt from the threaded insert on the stay, which extends from the small slot on top of the sampler. The stay supports the inlet hood during filter changes and calibrations.
3. Place the inlet hood on top of the sampler with the two mounting holes towards the rear of the sampler, lined up with the pivot screw holes. This may require moving the inlet hood to align the holes with the slots.
4. Insert the pivot screws through the holes in the inlet hood and sampler. The bolts should not be tightened at this stage.
5. Raise the inlet hood and insert the cassette on top of the sampler, if not already fitted. The thumb-screws above the control panel should be screwed up into the inlet hood until finger tight.
6. Apply sufficient down-ward pressure to the rear of the inlet hood to ensure a good seal between the size selective inlet and the filter cassette. Whilst applying this pressure, tighten the pivot bolts securing the inlet hood to the sampler. If fitted correctly, the inlet hood assembly will sit

horizontally and will exert even pressure on the filter cassette when secured. Figure 5 shows the correct alignment of the inlet hood on the sampler.

7. Check the cassette seals and check the pressure needed to tighten thumb screws and re-adjust the pivot bolts if required.

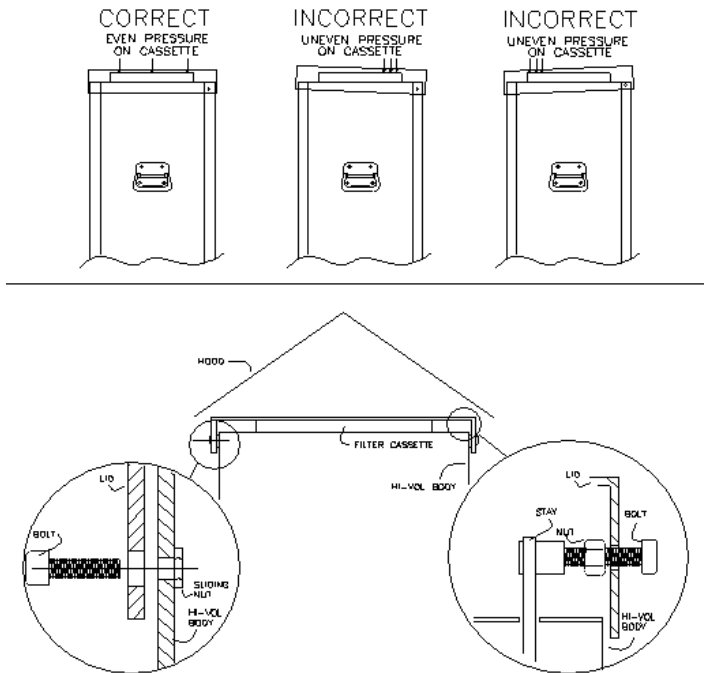

Figure 5 – HiVol hood attachment

8. Raise the inlet hood slightly and attach the support stay to the lid using the screw and nut supplied. The screw passes through the lid, then the nut, then into the stay. The bolt must go through the hole directly above the stay (not the one near the corner of the hood).
9. Tighten the nut against the threaded insert of the stay. The screw should be able to pivot when the lid is opened. Adjust if necessary.



Figure 6 – Attaching the support stay

10. Open the inlet hood and check that it opens freely. The stay is used to support the weight of the inlet hood during filter changes and calibration. The stay also prevents the lid from opening too far. The stay acts like a catch to prevent the lid accidentally falling.
11. Move the stay towards you to release the catch. Close the lid again and check that the cassette is evenly clamped when the thumbscrews are tightened.
12. Whenever the sampler needs to be transported, remove the inlet from the HiVol and pack the items separately in the original cartons.

2.2.2 PM₁₀ or PM_{2.5} Size Selective Inlet (SSI) Assembly (Option)

The SSI is packaged basically complete; only minor assembly is necessary. When removing the SSI from the shipping carton, take care not to damage or knock any part. Remove the cushioning material, lift the SSI from the carton and place it on the floor or on a workbench. Save the shipping container and packing material for future use.

1. Release the four inlet hook-catches and remove the top portion of the SSI. Place the top portion up-side down to prevent damage to the acceleration nozzles and seals.
2. Release the collection shim from its four clips and using the plastic handles, lift the shim carefully past the nozzles and out of the inlet.
3. Place the collection shim with the handle side up on a clean flat surface and spray the area between the circular cut-outs with a generous coating of Dow Corning "Slipicone" Silicone (or #316). Do not substitute any other grease or oil without contacting the supplier; particle bounce characteristics may be affected by changing the viscosity of the grease.
4. Using only the plastic handles, return the greased collection shim (greased side up) to the sampler inlet and secure with the four shim clips.
5. Replace the top portion of the sampler inlet and secure with the hooks and catches. The manufacturer's label should face towards the front of the sampler to ensure consistent orientation of the top section.
6. An insect screen should be fitted after the impaction stage, as shown in New figure & reference required to prevent insects finding their way into the filter as shown in.

Note: The tension on the catches should be evenly distributed between the four catches. If necessary, adjust the inlet hook-catches by loosening the lock-nut on the hook-catch rod, then wind the catch in or out. Hold the catch straight and tighten the lock-nut.

2.2.3 Installing the Muffler (optional item)

1. The muffler is an optional accessory. Install the threaded circular plastic tubing onto the side of the HiVol by screwing it on clockwise as shown below.
2. Attach the muffler by placing it over the threaded circular plastic tubing.



Figure 7 – Installing the optional muffler

2.2.4 Connecting a Wind sensor or Rain-gauge

Note: It is not possible to connect both a rain gauge and wind speed/direction sensor at the same time.

The wind speed and direction sensor and tipping bucket rain gauge are optional accessories. Mounting hardware is included. A 1.7m cable is supplied as standard. Other length cables may be ordered separately, and can be manufactured to any length specified.

Note: The wind sensor should be installed at a height of 10m if used for regulatory compliance. Alternatively the mounting arm and rotating adaptor supplied may be used to mount the wind sensor to the HiVol.

This bolts to the side of the HiVol cabinet using the fasteners supplied. It is necessary to remove the rear panel to attach the arm to the cabinet.

3. Remove the power cord before removing the rear panel. The rear panel is secured by screws in the top plate. When securing the arm, use the large washers supplied to prevent damage to the cabinet. The cable connects to the 6-pin socket on the side of the HiVol. A weatherproof cover is fitted to the socket to exclude dirt and moisture when not in use. This cover should be removed only when a cable is connected to the socket.

The rotating adaptor is for aligning the sensor to true North. The wind sensor should be aligned to true north rather than magnetic north. This is usually done using a hand-held compass and adjusting for the magnetic declination from true north.

- Align the directional markings on the wind sensor to the specified direction by rotating the adaptor, and then tighten the screws.

An alignment locating screw is fitted to the wind sensor that locates in a slot in the rotating adaptor. This screw should be tightened when the sensor is installed to electrically ground the sensor to the sampler. This allows removal of the wind sensor without the need to realign the mounting adaptor.

- Set the wind direction conditional sampling parameters in the Wind menu.

The optional rain gauge includes a bracket, which may be mounted to a 25-50mm pole, preferably over open ground away from the HiVol. The bracket may be mounted to either a vertical or horizontal pole, or to a vertical surface (eg. the top of a wall.)

The HiVol is factory configured for the wind sensor input (default configuration). If a rain gauge is used, the configuration should be changed.

- Refer to the Hidden Menu section for details of how to set up the HiVol for rain gauge or wind sensor input.

2.2.5 Connecting an External Trigger for Remote Activation

Refer to Section 3.5.2.3 for details on how to setup the Trigger menu for remote activation.

The external trigger voltage must be between 0 and 5v. If using a contact closure to trigger the HiVol then the signal must be pulled up to +5v with a 4.7kOhm resistor. +5V Pullup, ground and Trigger input are available on the external trigger cable.

Ensure the Trigger Signal to Trigger Ground voltage does not exceed 5V. To prevent damage to the HiVol, opto-isolated or relay contacts are recommended to connect the triggering device to the HiVol.

Refer to the cable diagram on next page for further details.

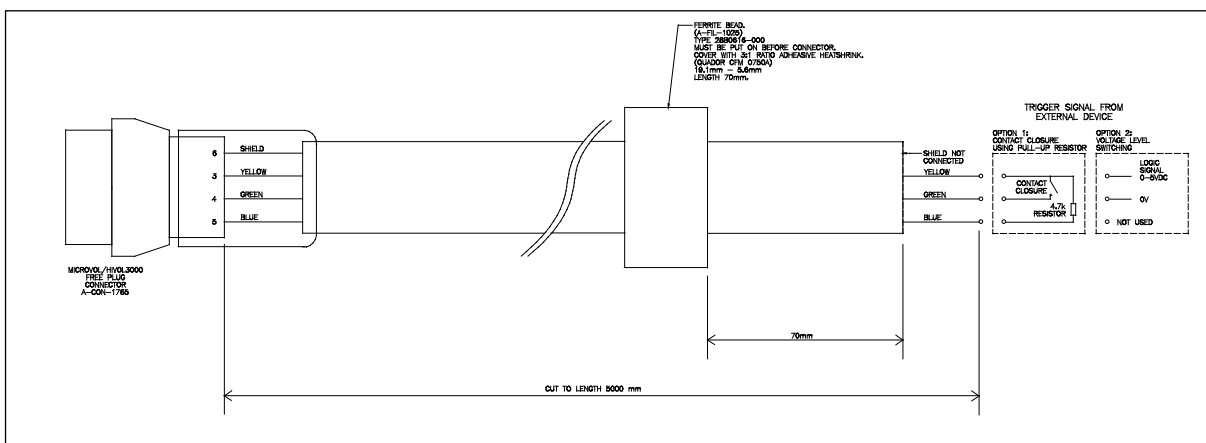

Figure 8 – External trigger output

2.3 Mounting/Siting

2.3.1 Siting

For guidance in the selection of sampling sites, the reader is referred to the latest Australian Standard AS/NZS 3580.1.1:2007 or US EPA Federal Register 40 CFR Part 58 Appendix E.

In general, a site is chosen to be representative of the location or the area type being monitored.

The following guidelines are presented as a guide to the selection of a site which should provide representative data.

1. The sampler should be located in an area with unrestricted ventilation. The sampler inlet should be located well away from buildings, walls and trees. An example of some Australian Standard minimum separator requirements for obstacles are shown in Figure 9. As a general rule the sampler should be at least 20 metres from buildings, walls and trees. The sampler should be located at least twice as far from the obstacle as the height of the obstacle. The sampler inlet should also have a minimum clear sky angle above the inlet of 120°.
2. Samplers should be located well away from local sources of pollution (eg incinerators, stacks or ducts, boilers etc) unless those sources are specifically under investigation.
3. Other siting considerations include good access, security, availability of reliable power, safety, and noise if the sampler is to be located in residential areas.

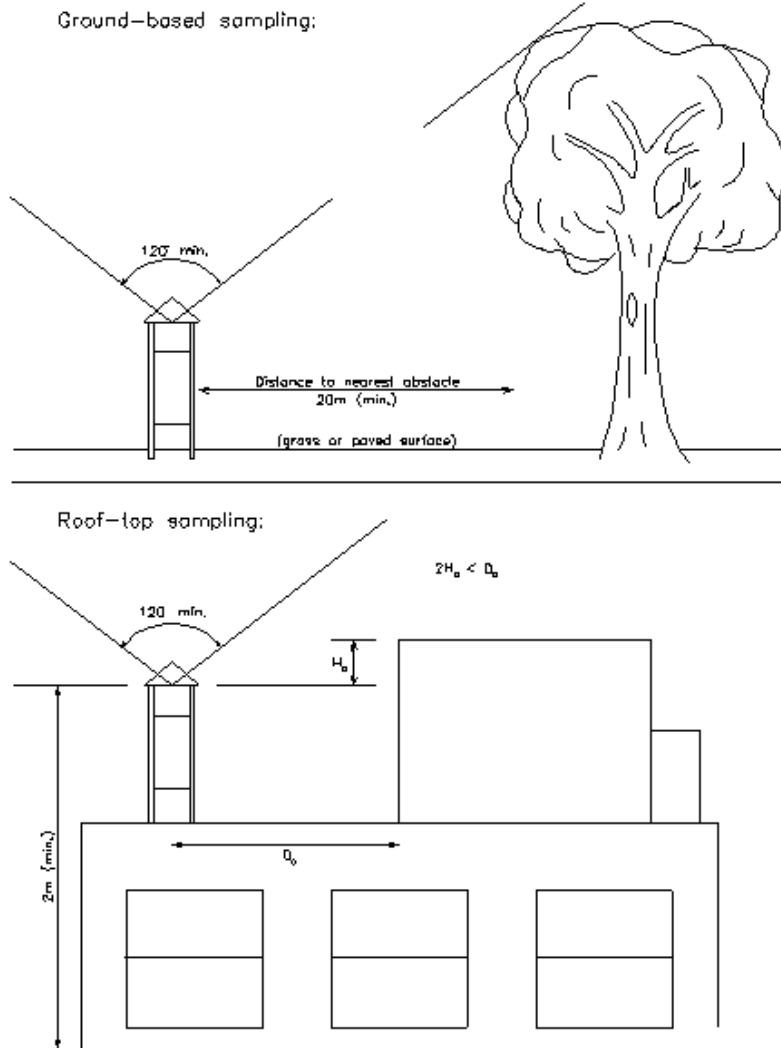

Figure 9 – Site selection guidelines

2.3.2 Mounting

The sampler must be installed on a level surface and must be securely fixed to the supporting structure. A smooth, sealed concrete slab is an ideal base. The sampler must be securely bolted through the sampler feet. Guy wires may be attached to securely hold the sampler. In either case, any timber packaging located under the sampler should be removed during operation, and kept for future transportation.

Improper fastening of the sampler could result in incorrect readings and degradation of the equipment. Strong winds could also topple the sampler and lead to damage.

No warranty claims will be accepted unless the sampler has been properly secured at the sampling site, and shipped using correct packing material.

2.4 Instrument Set-up

2.4.1 Power Connections

Note: Ensure that you have ordered the appropriate HiVol for your region. Ecotech provides both a 240V version (standard) and a 110V version.

When powering the HiVol with a generator ensure that the generator is earthed by a qualified electrician otherwise serious damage will occur to the sampler, which is not covered under the warranty.

The following reference may be useful (in Australia):

AS/NZS 3010:2005 Electrical installations – Generating sets (Generators)

This Standard sets out the minimum safety requirements related to the use of generating sets for the supply of electricity at voltages normally exceeding 50 V a.c. or 120 V d.c.



CAUTION

Check that the supply voltage is 200-240Vac or 100-120Vac as appropriate. If this is not the case, then an alternative power set-up will be required. Ask a qualified electrician to measure the voltage.

A qualified electrical contractor must fit the wireable socket to an appropriate supply cord, according to local wiring standards. The power cord shall be fitted with an earth conductor.

The power supply to the HiVol must provide an earth path via the plug.

It is recommended that a class II earth-leakage circuit breaker (ELCB) – also known as GFI or RCD - be installed on the power circuit to the sampler. The ELCB shall be appropriately rated for all of the equipment installed on the circuit. Earth and neutral cables should be linked as shown in Figure 10 – HiVol power connection.

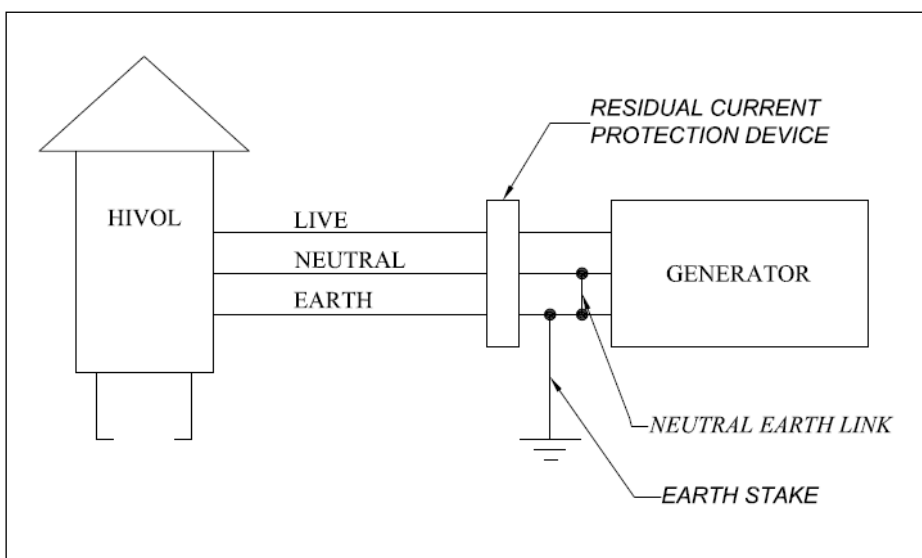

Figure 10 – HiVol power connection using a generator

Note: This drawing is a recommendation only. Ecotech accepts no responsibility for any damage as a consequence of this arrangement or any other power connection arrangement.

The purpose of this drawing is to highlight that the HiVol 3000 should not be operated for a floating supply. A generator installation should be performed by a competent electrical contractor, in accordance with relevant standards.

There are no circuit breakers fitted inside the HiVol. Motor current is limited by the internal variable speed drive.

The power connection to the sampler must include the orange weather-proof cap and this must be screwed into position whenever the sampler is in the field. The weather-proof cap ensures the desired water-proof rating is achieved and prevents loosening of the plug due to vibration. The weather-proof cap is designed to be inserted into the socket. A wirable 10A socket is supplied for this purpose.

Attach the HiVol to a power outlet that will not be needed for other purposes, so that the power supply to the sampler will not be disturbed.

2.4.2 Exhaust Connections

A 50mm PVC flap valve is provided to prevent wind blowing back through the pipes when the blower motor is not running. This prevents the filter paper being disturbed during non-sampling periods.

It is recommended that the sampler be operated with approximately 3m of exhaust tubing. The exhaust tubing prevents recycling of filtered air, and also assists in the reduction of noise.

A suitable exhaust duct may be constructed with a 50 mm BSP female connector, two 90° PVC elbows and 3.5m of 50 mm PVC tubing. The flap valve can be installed on the end of the duct. An alternative is to use a flexible hose attached to the HiVol with a 50 mm BSP female connector.

2.4.3 Muffler for Noise Reduction

An external muffler is available as an option. It may be connected to the exhaust outlet, by first removing the exhaust flap. The exhaust should then be ducted away from the sampler as described above.

2.4.4 Filter Selection for TSP Sampling

High volume filter media are available from a number of commercial suppliers. The choice will be dependent upon the specific analytical requirement on the collected particulate matter.

The most commonly employed filter medium is glass fibre. However, quartz and teflon-coated glass fibre filters are widely used because they are less prone to artefact formation than the standard glass fibre filters. Glass fibre filters being alkaline can react with acid gases in the atmosphere to form artefact sulphate and nitrate compounds on the filter.

It is important that the filter medium selected is capable of maintaining a flow rate of at least $1.0\text{m}^3/\text{min}$ ($60\text{m}^3/\text{hr}$) at all times throughout a typical 24 hour sampling period.

The minimum collection efficiency must be 99 percent as determined by the DOP test (ASTM-2986) for particles of $0.3\ \mu\text{m}$ diameter.

2.4.5 Filter Selection for PM₁₀ and PM_{2.5} Sampling

Filter selection for PM₁₀ and PM_{2.5} sampling is more critical than for TSP sampling. Any filter that is prone to artefact formation and adds substantially to the mass gain is not acceptable. This problem is greater for PM₁₀/PM_{2.5} sampling, due to the smaller mass of particulate matter collected and hence artefact formation becomes more significant.

If sampling in regions that may experience acid gases such as sulphur dioxide or nitrous oxides, then use of a neutral filter media such as quartz is recommended.

Teflon-coated glass fibre filters also have low artefact potential, however they may experience overloading in heavy particulate loading situations.

The major disadvantage of quartz filters is their poor tensile strength and poor handle-ability whereas teflon-coated glass fibre has excellent strength and handle-ability.

The integrity of the selected filter media should be assessed by handling, weighing and installing on an inoperative sampler (ie. field blank). The blank filters should be treated identically to sample filters except no air sample is passed through them.

High volume filter media are available from a number of commercial suppliers. The choice will depend upon the specific analytical requirement on the collected particulate matter.

It is important that the filter medium selected is capable of maintaining a flow rate of at least 1.13m³/min(67.8m³/hr) at all times throughout a 24 hour sampling period.

The minimum collection efficiency must be 99 percent as determined by the DOP test (ASTM-2986) for particles of 0.3 µm diameter.

2.4.6 Filter Preparation

Note: When handling filter papers, clean laboratory gloves should be worn. Only handle extreme edge of the filter paper.

1. Inspect each filter for defects such as loose material and discolouration. Use a light table to check for pinholes and non-uniformity. Discard any filters that are defective in any way.
2. Code each filter with a unique identification number. The number should be lightly stamped on the underside of the filter on an outside corner.

Note: If the collected particulate matter is to be chemically analysed, then a suitable number of filters should be set aside as controls or blanks from each batch of filters.

3. Filters must be equilibrated to conditions of the balance room for at least 24 hours before weighing.

Filter equilibration conditions for PM₁₀ (US EPA Appendix J Part 50, AS/NZS 3580.9.6:2003)

The filter conditioning environment must be within the temperature range of 15 to 30°C and controlled to within ± 3°C. Similarly the humidity range of the conditioning environment must be within the range of 20% to 45%* RH and controlled within ± 5% RH.

* AS/NZS 3580.9.6:2003 upper limit is 50% RH.

Re-weighing of exposed filters should be performed at similar conditions of temperature and humidity as the initial weighing.

4. Prior to weighing filters an analytical balance with a sensitivity of 0.1mg should be zeroed then checked using a standard weight (Class B working mass, stainless steel or nickel chromium alloy or Class S weights of NBS specification) of mass similar to the mass of the filter (nearest gram).
5. Weigh each filter to the nearest milligram. Record the weight and identification number of each filter on the laboratory data sheet. Weighed filters should be stored in a dust-proof container.

Note: Examine each exposed filter sample for damage and for signs of air leakage.

Leakage around the seals may be identified by diffuse edges on the boundary between the collected particulate matter and clean filter. Leak-free seals produce a sharp well defined boundary. Small holes in the filter will be characterised by a dark spot where the air has preferentially flowed.

2.4.7 Installation of Sample Filter

The filter cassette has two components, an upper and a lower section. The lower section has a mesh screen which supports the sample filter.

1. At the sampling site unlock and open the upper door. Undo the thumb-screws securing the front of the sampler inlet.
2. Raise the sampler inlet and remove the filter cassette. Separate the upper and lower parts of the cassette and install a filter in the centre of the lower cassette.
3. Re-assemble the cassette and install the loaded cassette on the top plate of the HiVol between the locating brackets.
4. The sampler inlet should then be lowered and secured using the thumb-screws. Apply slight downward pressure to the lid while tightening the thumb-screws. This ensures a good seal on the cassette.

Note: Filter installation should not be attempted during adverse weather conditions. Filters should be loaded into the cassette in a clean environment and must be handled with care.

Filters can be pre-loaded into the filter cassette (spares are available) and transported to the sampling site in a protective container eg zip-lock bag.



Figure 11 – Installing the loaded filter cassette

2.5 Transporting/Storage



CAUTION

The weight of the HiVol exceeds the OH&S limits for lifting by one person. Lifting should be performed by two people (one on either side) using the handles supplied.

1. Carefully transport the sampler to the monitoring site. The sampler should be transported in an upright position at all times, and the original packing should be used to prevent damage. The HiVol and inlet hood should be transported separately. Whenever the inlet hood is removed for transportation, re-fit the pivot bolts to the sampler to prevent them being misplaced. Remove the optional wind sensor and bracket if fitted.
2. On arrival at the monitoring site, the equipment should again be inspected for damage. Ensure the inlet hood (especially SSI type) is free from dents or deformation which may affect collection efficiency.
3. Fit the inlet hood to the sampler as described in Section 2.2.1 Inlet Hood – Assembly & Adjustment. Secure the sampler to prevent it falling over.

This page is intentionally blank.

3. Operation

3.1 Warm-up



CAUTION

When power is connected the blower motor may start-up immediately. Alternatively, the cooling fan may be heard. The cooling fan will run whenever power is connected and switched on. This is normal.

With a filter paper installed in the filter cassette, switch on the power at the supply. The HiVol has a power switch located inside the cabinet near the power socket (240V version). This is concealed by the lower door. The LCD display should now display the Main Screen.

The HiVol flow rate must be calibrated after installation at a new site. Refer to 3.6 for details.



Figure 12 – Power switch location

3.2 General Operational Information



Figure 13 – HiVol 3000 control panel

The HiVol 3000 is microprocessor based and features internal data logging of flow and meteorological parameters.

The internal data logger stores time based records at user-selectable intervals. The data includes Date and Time, flow-rate (volumetric), sample volume (uncorrected and corrected to Standard Temperature and Pressure conditions), average temperature, pressure, wind speed and wind direction or rainfall information. Values stored in the sampler may be downloaded via the RS-232C serial port.

The HiVol 3000 includes an input connector for wind speed and direction. These inputs are averaged and stored in the unit, and may be used as triggers for conditional sampling (eg. sampling when the wind direction is within a specified range). The HiVol also incorporates a time clock and programmable timer enabling multiple time-based sampling programs to be configured.

3.2.1 HiVol Sampling Protocol

The HiVol uses a number of logical (conditional) parameters to decide when it should switch the sample pump on.

The pump will be energised when all conditional parameters are satisfied. The conditional parameters can be summarised as follows:

- Is the current date after the specified Start Date and Time?
- Is the current date before the specified End Date and Time?
- Is the current time within one of the programmed Daily sampling times? (Between any of the 6 programmable On Time/ Off Time periods).
- Is the current Day Of Week a specified sampling day?
- Is the wind speed and direction sensor data within the programmed range?
- Is the internal power supply voltage above the lower limit (typically 11V)?

If all of the conditional parameters are satisfied (All 'YES' values displayed in the Status Menu), then the HiVol sample pump will operate, and a sample will be collected on the filter paper.

In order to make the HiVol pump operate continuously, it is possible to set the HiVol with parameter values that ensure all conditions are satisfied for long periods of time. The only exception is that of the internal power supply voltage, which should always be maintained above 11VDC. To set the HiVol 3000 to run continuously, enter the Setup menu:

Select Set-up Menu, then Times Menu

1. Select Start Date: Enter a date that is before the current date.
Example: Set the Start Date as yesterday's date or earlier.
2. Select End Date: Enter a date in the distant future.
Example: Set the End Date as tomorrows date or later.
3. Select Daily: Set On Time 1 to 00:00, Set Off Time 1 to 24:00.
4. Select Weekly: Set all days to YES.
5. Set Days/cycle to 1.

Select Set-up Menu, then Wind Menu

1. Set CCW W.Dir to 0
2. Set CW W.Dir to 360
3. Set LO W. Speed to 0
4. Set HI W. Speed to 100

The HiVol's data logger collects data even when the blower motor is not running. The data are collected at regular intervals, called the averaging period. The averaging period is set in the Logger Setup menu. The data that are logged are the average data value during the averaging period, with the data being written to memory at the end of that period.

Data from up to 150 averaging periods may be stored in the HiVol. Once the data logger memory is full, the HiVol stops collecting data. The HiVol begins collecting data when the logger accumulator is cleared. When setting the averaging period, keep this in mind. If you want to collect one day of data, it will be necessary to set the Logger Setup Averaging period to at least 12 minutes. If the averaging period is set to one hour, up to 150 hourly averages of data will be collected. This equates to almost 6 days of logged data.

The actual number of data points can vary depending on the number of characters being stored, which can change according to the values being stored.

Note: Data are also collected when the HiVol is in manual mode.

Set-up Major Faults Menu

When the flow from a HiVol drops considerably, an error occurs and the instrument stops sampling, then after a delay, it attempts to restart.

“Filter Blocked” error is displayed when a drop in flow occurs and indicates that the filter is full/saturated with particulates.

“Motor Drive Error or Major Blockage” error is displayed when the drop in flow is large and is caused by:

- The blower motor not working properly (motor not turning.).
- Either a high or low supply voltage to instrument.
- Large blockage within the instruments flow path.

When sampling with a Size Selective Inlet the instrument must remain at a specific flow for the SSI to take representative samples. When the blower motor is unable to reach the required flow rate for 2 minutes a filter blocked message is displayed and the unit stops sampling.

The instrument will attempt to reset itself a number of times (user definable) and if unsuccessful the instrument will shut down until an operator visits the instrument and repairs the fault/changes the filter and hits the exit key (refer to Section 3.5.2.3 for more details).

3.2.2 Menu Operation

The HiVol is equipped with a six-function keypad. The keys are:

- Exit
- Page up
- Select
- Enter
- Up arrow
- Down arrow

1. To enter the menu system press Select or Enter.
2. To move the cursor to a different menu item press the Up arrow or Down arrow. If the current menu is larger than four items then the screen will scroll up or down when necessary.
3. To select the menu item under the cursor press the Select or Enter key.
4. To exit to the previous menu press Page up.

3.2.3 To exit from the menu system press Exit.Changing Menu Settings

Each menu comprises a number of menu items. The menu item contains a description on the left and an operand on the right. The operand types are:

Type	Operand Text
Floating-point (FP) number	6 characters max.
Long floating-point number	8 characters max.
Integer	3
Long integer	8
Text	6 characters max.
Time	hh:mm:ss (24-hour format)
Date	dd/mm/yyyy (day/month/year) mm/dd/yyyy (optional format) yyyy/mm/dd (optional format)
Day	SUN, MON, TUE...
YesNo	YES, NO
Submenu	→

When an editable menu operand is selected, the following functions are available:

1. To move the cursor left or right, use:
←Page up or Select →
2. To change the character under the cursor press Up arrow or Down arrow.

Note: Some characters are fixed cannot be changed.

The order in which the characters appear is:

FP first character	.0123456789
FP other characters	.0123456789
Integer	0123456789
Time/Date	0123456789
Text	!"#\$%&'()*+,-./0123456789;<=>? @ABCDEFGHIJKLMNopqrstuvwxyz[\]^_ 'abcdefghijklmnopqrstuvwxyz
Day	SUN MON TUE WED THU FRI SAT
YesNo	YES, NO

3. To accept the edited value press Enter.
4. To discard the edited value press Exit.

3.3 Main Screen

The HiVol 3000 uses a menu system to organise the operating parameters and settings. The layout of the menu system is straightforward and easy to learn.

Note: Only four lines of text are displayed on the HiVol. Access other lines by pressing the up and down arrows.

Motor On

Table 2 – Main screen with motor on

Auto/Manual	20/09/2008	Displays current mode & date
Sampling	11:53:23	Displays current time
Flow	M3/H 67.80	Displays current flow-rate
Temp.	C 22.90	Displays current temperature
Press	mmHg 763.4	Displays current barometric pressure

Motor Off

Table 3 – Main screen with motor off

Ecotech	20/09/2008	Displays current date
HiVol	11:53:23	Displays current time
(A one-line status message is displayed)		Displays status message stating why pump is off

Status Messages

Manual Mode Off:	Manual mode active but no sampling occurring
Low Input Voltage:	Voltage received by instrument is too low (5v default)
No Days Enabled:	No day of the week is set to enabled (Section 3.5.2.1)
No Times Enabled:	All times are set to 00:00 (Section 3.5.2.1)
Next Sampling:	Displays time and date of next sampling event
Wind Out of Range:	Wind is outside range set within Section 3.5.2.2
Not Triggered:	Trigger is not activating sampling event (Section 3.5.2.3)

To enter the menu system press Select or Enter.

3.4 Sampling

3.4.1 Pre-Sampling

An important part of collecting and evaluating data is the quality of the results. Users of the U.S. EPA Reference Method for PM₁₀ must adopt quality assurance procedures consistent with those provided in the following documents. No U.S. EPA documents on PM_{2.5} sampling exist at time of publishing.

Quality assurance Handbook for Air pollution Measurement Systems, Volume II:Part I – Ambient Air quality Monitoring Program Quality System Development. EPA-454/R-98-004 (August 1998). Available at: <http://www.epa.gov/ttn/amtic/qabook.html>

Quality Assurance Guidance Document 2.11 – Monitoring PM¹⁰ in Ambient Air Using a High-Volume Sampler Method. (Draft) September 1997. Available at: <http://www.epa.gov/ttn/amtic/qabook.html>

Documentation is required for legal purposes and to ensure data reliability. A sample Field Data Record is included at the end of this manual. The following information must be recorded:

- Reference to the local Standard/ Method
- Filter serial number
- Sampling site identification number/location/address
- Sampler identification number
- Type of inlet (SSI manufacturer and model information)
- Starting time and date
- Initial sampling flow rate
- Final sampling flow rate
- Summary of conditions that may affect the results, such as weather conditions, construction activities, dust storms, etc.

- Operators initials or signature
- Runtime reading at start and end of sampling
- Corrected sample volume
- Comments concerning voided samples
- Estimate of uncertainty in method

3.4.2 Beginning Sampling

1. Install a pre-weighed and numbered filter into the filter cassette. Ensure the filter is centrally located on the support screen before placing the top section of the cassette on the filter.

Note: Check filter for pinholes or damage prior to installation in sampler. During adverse weather conditions filters should be pre-loaded into cassettes in a protected area prior to installation in a sampler.

Note: Filters are normally installed rough side up with identification number located on the bottom outer-most edge of the filter. Filters may be fragile and should be handled carefully. To prevent contamination filters should be handled on their outer edges using gloves.

2. Insert the loaded filter cassette into the locating stop on top of the sampler and close the inlet hood. The filter cassette is held in place and sealed by carefully lowering the inlet hood onto the top of the cassette. The filter cassette is clamped down by screwing the two thumb-screws above the control panel into the inlet hood.
3. Program the timer and check that the clock is on the correct time. Download the data from previous sample periods and clear the logger if required. Refer to Section 4 & 3.5.2.4 if required.

Note: If data is not cleared any CV (corrected volume) measurements will be void as they will encompass all temperature and pressure values since data was last cleared. If using CV measurements ensure data is downloaded and then cleared each time the filter is replaced.

4. Switch the sampler on and if necessary adjust the flow-rate. The flow rate through a sampler fitted with a SSI inlet hood must be maintained at $67.8 \text{ m}^3/\text{h}$ ($1.13 \text{ m}^3/\text{min}$) $\pm 10\%$ at existing temperature and pressure conditions throughout the sampling period to achieve the specified particle size cut-point. A flow-rate of $70 \text{ m}^3/\text{hr}$ is suitable for TSP sampling. In any case, do not operate the sampler outside the range of 45 to $96 \text{ m}^3/\text{hr}$, or its ability to compensate flow-rate will diminish.
5. Run the sampler for 5 minutes using Manual mode, to allow the control circuitry to stabilise, then record the flow-rate indicated on the digital display. The flow-rate should be stable.
5. Turn Manual mode off, then set the timer to operate on the desired day and for the period required. The POWER switch should be left on. If required, fill in a copy of the HiVol 3000 Program Record shown on the next page.
6. For routine particulate monitoring (TSP PM_{10} and $\text{PM}_{2.5}$), sampling is carried out for 24 hrs every sixth day from midnight to midnight. This can be set using the 1 in 6 day timer facility that is built in.

7. To determine the final flow-rate at the end of the sampling period, operate the sampler for 5 minutes and record the final flow rate.

Note: The difference between the initial and final flow rates should not be significantly different. Variations greater than 2m³/hour may indicate a particle overload situation which has exceeded the compensating ability of the flow controller.

3.4.3 Conclusion of the Sampling

1. Download the data using a laptop computer. Alternatively, from the Status Menu, record the Run time, Total volume and Corrected Volume and final flow rate (Manual mode). Check that the clock is on the correct time. Clear the logger. Refer to Section 3.5.2.4, Logger Set-up Menu.
2. Remove the exposed filter carefully from the filter cassette handling only the outer edges. Fold the filter in half so that the exposed surfaces are in contact. Place the sample in a dust proof container for transport to the laboratory.
3. Before installing a new filter remove any surface dust from the cassette and top of the funnel assembly with a damp lint-free cloth.

3.4.4 Recording Sample Corrected Volume & Clearing Logger

To record corrected volumetric measurements for use with filter mass measurements (for concentration calculations) and then to clear this number for next sampling cycle, follow the procedure below:

1. Press ENTER to bring up the main menu.
2. Press ENTER to select the STATUS menu.
3. Press the DOWN arrow to view COR. VOL M3 and record this value.
4. Press EXIT.
5. Press ENTER to bring up the main menu.
6. Press the DOWN arrow to select the SETUP menu then press ENTER.
7. Press the DOWN arrow to select the LOGGER SETUP then press ENTER to select.
8. Press the DOWN arrow to select the CLEAR ACCUMULATOR and then press
9. ENTER, press the DOWN arrow to choose YES then press ENTER to confirm.
10. Press EXIT.

The HiVol is now ready for another 6 day cycle.

3.5 Menus & Screens

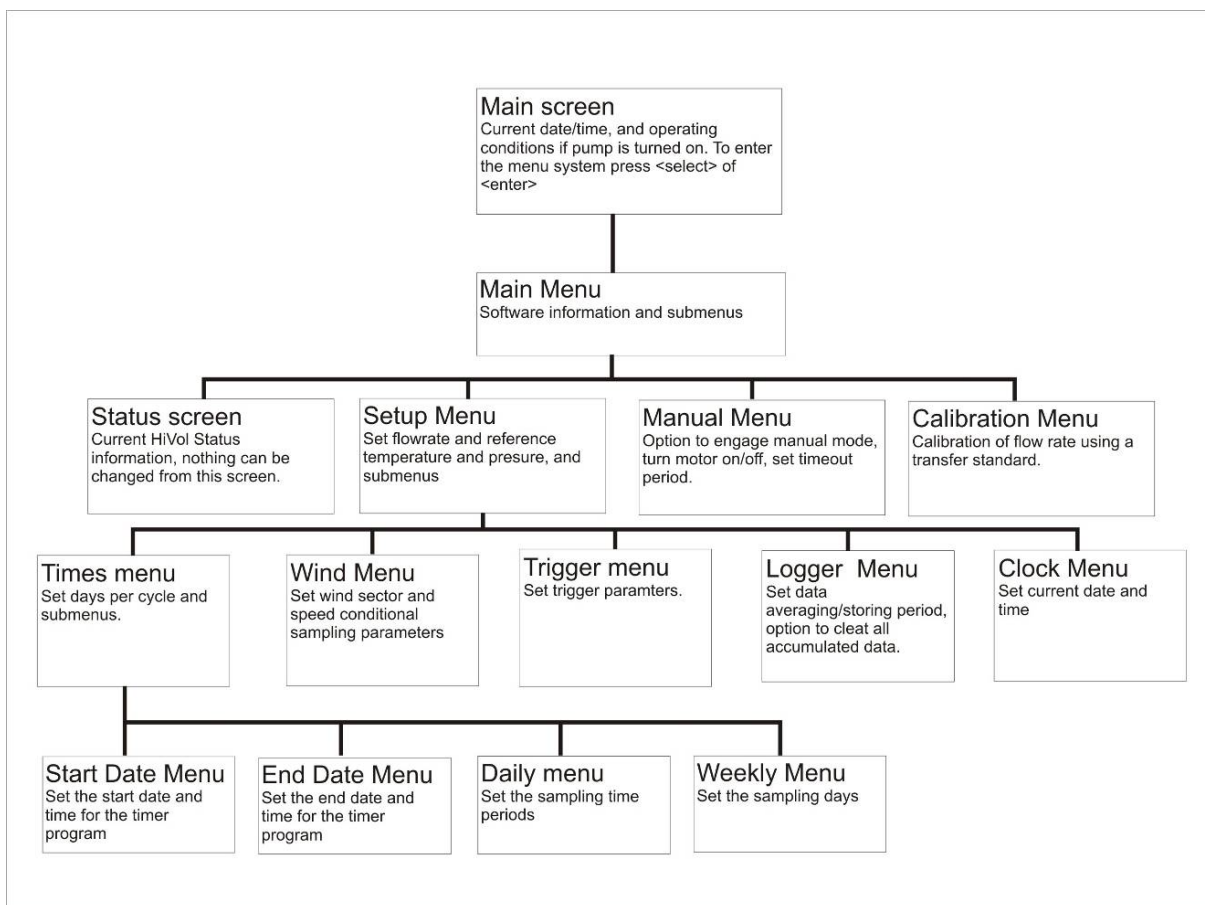

Figure 14 – Menu structure

Main Menu

Table 4 – Main menu

Status	→	To Status Screen
Set-up	→	To Set-up Menu
Manual	→	To Manual Menu
Calibration	→	To Calibration Menu
S/W version	V1.23	Displays software version information

3.5.1 Status Screen

The Status Screen displays current HiVol status information. The data cannot be changed from this screen. Sample volume and Corrected sample volume data are updated every minute, all other data updates instantly. Corrected sample volume is used to calculate particulate concentration and has been corrected to standard Reference conditions.

Note: All Yes/No conditions must be met before sampling takes place in AUTOMATIC sampling mode.

Flow

Displays current volumetric flow-rate

Tot. Vol.

Displays sample volume

Temp.

Displays current ambient temperature

Press.

Displays current barometric pressure

Wind Sp.

Displays current wind speed

Wind Dir.

Displays current wind direction*

Rain

Displays accumulated rainfall

Cor. Volume

Displays sample volume corrected to STP

RunTime

Displays sampling duration (pump running)

Pwr Supply

Displays current power supply voltage

M/S Ratio

Displays pump load (0.000-2.000)

Day of Week

Displays current day of the week

Start Dt OK?

Is current date after timer start date?

End Dt OK?

Is current date before timer end date?

DayOWeek OK?

Is this an active sampling day?

Time OK?

Is current time/date combination active?

Wind OK?

Is wind condition (sector/speed) active?

Power OK?

Is power supply voltage in range?

Wind OK?

Is wind condition (sector/speed) active?

Power OK?

Is power supply voltage in range?

* - if Wind Sp. Parameter is zero, wind direction displays zero data

Note: "Tot. Vol.", "Cor.Volume" and "RunTime" parameters may be reset to zero by Clearing Accumulated data in the Setup → Logger Set-up Menu.

3.5.2 Setup Menu

The Setup Menu contains a number of sub-menu items and some direct entry parameters, where the user can program various parameters.

Times menu

Refer to Section 3.5.2.1

Wind menu

Refer to Section 3.5.2.2

Trigger menu

Refer to Section 3.5.2.3

Logger menu

Refer to Section 3.5.2.4

Clock menu

Refer to Section 3.5.2.1

Flow Alarm menu

Refer to Section 3.5.2.2

Major fault

Refer to Section 3.5.2.3

Flow

Set sampler flow-rate, m³/hour

Ref.Temp.

Set STP standard temperature, °C

Ref. BP

STP standard pressure, mmHg

Size Select

Sets SSI flow rate limits active

Protection

Sets restrictions on changes to certain parameters

Note: Flow-rate should be set at 67.8m³/hour (based on 40ft³/min US EPA standard) when using size selective inlets. The size selective inlet particle cut-point will be most accurate when the flow-rate is set 67.8m³/h. Do not set the flow rate below 45 or above 96 m³/hour.

Note: Ref. Temp. and Ref BP: Ensure these are set to Standard Temperature and Pressure Conditions (varies between different countries).

Size Select Function

This function determines what happens when the filter blocks up and the flow rate can no longer be maintained at the set value. Setting this parameter to “YES” activates low flow-rate limits. If the flow rate drops below the set flow rate for more than about 45 seconds, the FILTER BLOCKED screen is displayed and the motor stops.

This feature means that the sample need not be discarded if a blocked filter causes the flow-rate to drop below the required value for the Size Selective Inlet. The RunTime, Total Volume and Corrected Volume will stop accumulating at this point.

Note: For US EPA regulatory PM₁₀ monitoring, sampling is generally required for 24h ± 1h.

If this feature is not required, it can be de-activated by setting Size Select parameter to NO. For example, TSP sampling can usually tolerate some decrease in the flow-rate without invalidating the sample.

If this parameter is set to NO, the Filter Blocked screen will not appear until the flow-rate drops to half of the set flow rate.

Filter Blocked:

Filter blocked screen

Replace Filter Before Restart:

Press Exit or PageUp to resume normal operation after replacing the filter.

3.5.2.1 Times Menu

The Times Menu contains programmable timer settings. Note that times should be entered in 24-hour format.

Start Date

To Start Date Menu

Date: Set the start date for the timer program

Time: Set the start time for the timer program

End Date

To End Date Menu

Date: Set the end date for the timer

Time: Set the end time for the timer

Daily

Up to six on and off periods can be programmed into the timer. If the current time is within any of the six programmed periods, then the Time condition will be satisfied. Note that times should be entered in 24-hour format. For a 24hour sample enter 00:00 to 24:00.

On Time 1	09:00
Off Time 1	17:00
On Time 2	00:00
Off Time 2	00:00
On Time 3	00:00
Off Time 3	00:00
On Time 4	00:00
Off Time 4	00:00
On Time 5	00:00
Off Time 5	00:00
On Time 6	00:00
Off Time 6	00:00

Above example shows 9.00am – 5.00pm program.

Weekly

The weekly menu allows the user to choose which days the HiVol sampler will take samples on.

Sunday	NO
Monday	YES
Tuesday	YES
Wednesday	YES
Thursday	YES
Friday	YES
Saturday	NO

Example above shows Monday to Friday program, with no sampling on Saturday or Sunday.

Days/Cycle

For regular sequence set this parameter to 1. To set a timed sequence of a different number of days, see below.

Days/cycle: It is possible to program a timer sequence that repeats after a fixed number of days. An example is to program a 6-day sequence for EPA sampling by setting the Days/Cycle parameter to 6. In this way, it is possible to program the HiVol 3000 to collect a sample on Friday, then the following Thursday, then the following Wednesday, etc. which commences at the programmed Start Date and will continue until the End Date is reached.

All conditions must be met for the sampling to commence, so make sure that the Start Date, End Date, Daily and Weekly parameters have the parameters set correctly. It is possible to program a 6 day sequence, which never samples on Sundays for example, by setting the Sunday parameter to NO in the Weekly Menu.

Example

To program a 6 day sequence, with the first run day as 21/06/2005 for a 24 hour sample period starting at 0000hrs:

Start date:	21/06/2005
Start time:	00:00
End date:	1/1/2100 (i.e. some point in the distant future)
Daily:	Set On Time 1 to 00:00 Off Time 1 to 24:00
Weekly:	all days to yes
Days/cycle:	6

Note: For an n-Days/Cycle sequence the Start Date is a sampling day. The HiVol determines subsequent run days based on the Start Date.

3.5.2.2 Wind Menu

The optional wind sensor may be used for conditional sampling. (See Section 2.2.4). The data logger automatically collects wind speed and direction data at the intervals set in the Logger Setup Menu.

The Wind Menu contains wind sector and speed conditional sampling parameters. When the wind direction angle has been greater than the counter-clockwise wind direction, but less than the clockwise wind direction, and has been greater than the Low wind speed limit but less than the High wind speed limit, for between 60 and 80 seconds, the Wind condition is satisfied.

If all other conditions are satisfied (eg. programmable timer settings), then the HiVol motor will operate and sampling will take place. Once this condition is satisfied, the HiVol will sample for at least 40 seconds. This time delay prevents rapid on/off cycling if the wind condition is borderline. To over-ride wind conditional sampling, or if there is no wind sensor connected, set the parameter values as shown so that the wind conditions are always satisfied.

CCW W. Dir

Set Counter-clockwise wind direction.

CW W. Dir

Set Clock-wise wind direction.

LO W. Speed

Set Low wind speed limit.

HI W. Speed

Set High wind speed limit.

Set CCW W.Dir

This is the compass direction of the counter-clockwise (CCW) end of the ACTIVE sector.

Set CW W.Dir

This is the compass direction of the clock-wise (CW) end of the ACTIVE sector.

Also set the Low and High wind speed limits for sampling.

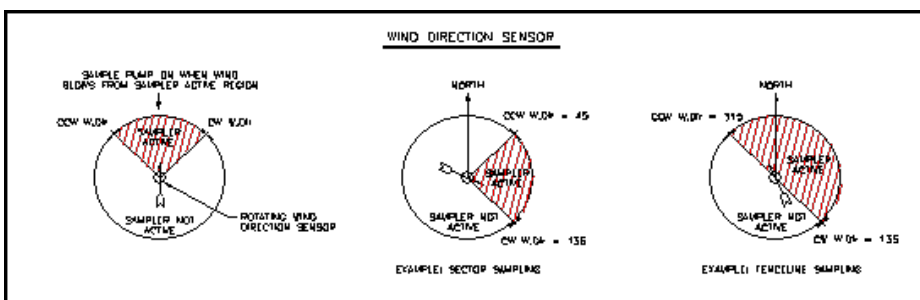

Figure 15 – Conditional sampling and wind direction sensor set-up

3.5.2.3 Trigger Setup Menu

Trigger Lo

Set trigger voltage range lower limit (V)

Trigger Hi

Set trigger voltage range upper limit (V)

OFF Delay

Set sampling period in hours:minutes

ReTrigger

Set retrigger mode YES/NO

The trigger works in conjunction with other conditional parameters. Check other Setup menu parameters to ensure they don't interfere with the Trigger program (for example Times and Wind settings.) Likewise, if external triggering is not required, set the trigger parameters so that they do not interfere with other programs.

The external trigger can be disabled by setting Trigger Lo and Trigger Hi to the same value (typically zero.) Setting OFF Delay to 00:00 will behave as if it were set to 00:01 - it does not disable the trigger function, and if triggered, the sampler will run for 1 minute. The RunTime parameter will also increase by 1 minute in this situation.

Note: It is necessary to disable the Wind function if using the Trigger function to control the HiVol. This is achieved by setting the wind direction range from 0 to 360 and wind speed from 0 to 100 as described in Section 3.5.2.2.

The Trigger Menu contains parameters for specifying an external trigger to start the HiVol sampling period.

Example

A separate gas analyser might be used to trigger the HiVol to start sampling when the gas concentration reaches a certain alarm level. You could also use a contact closure (switch or relay) to start and stop the HiVol when this level is reached.

The data logging features and parameters in the Status menu continue to function as normal. The triggering device must have either a contact closure or logic output signal (0-5VDC). A cable will be required to connect the triggering device to the HiVol.

For details of the electrical connections refer to Section 2.2.5.

1. External triggering uses the wind direction input connector and internal circuitry to monitor the external trigger, so wind control and external trigger cannot be used together.
2. The Trigger Lo and Trigger Hi parameters specify the voltages that the external trigger voltage must be between to trigger the HiVol. If these voltages are the same then external triggering is disabled.

3. If the external trigger is a contact closure then Trigger Lo should be 0.5V and Trigger Hi should be 6V.
4. To trigger above a set voltage, set Trigger Lo to that switching voltage and Trigger Hi to 6.
5. To trigger below a set voltage, set Trigger Lo to -1 and Trigger Hi to that switching voltage.
6. The OFF Delay specifies the time in hours and minutes that the HiVol continues to sample after triggering.
7. Unlike the wind sensor menu, the status of the trigger device is checked 'on the minute' (when the seconds of the HiVol clock reach "00" seconds.)
8. The HiVol switches on when a valid trigger is received. The HiVol will then sample for a set time duration, called the "OFF Delay". Trigger function uses a Trigger Time counter to count up to the OFF Delay value.
9. A parameter called ReTrigger controls how the HiVol deals with repeated trigger signals during the active sampling period.
10. If the ReTrigger parameter is set to YES, then each time the HiVol clock reaches :00 seconds, the Trigger Time counter resets to zero if the trigger condition is met, ie. The trigger operates from the end of the last valid trigger signal.
11. If the ReTrigger parameter is set to NO then the OFF Delay operates from the start of the trigger signal. The Trigger Time counter will reset only if the trigger goes off for a :00 crossing (HiVol clock reads hh:mm:00), and then retriggers at a later :00 crossing. This means that if the initial trigger is still active at the end of the OFF Delay period, then the HiVol will stop sampling until the trigger goes off and then on.

3.5.2.4 [Logger Set-up Menu](#)

AvPeriod

Set data averaging/storage period

Clear Accum

Clears all stored and logged data and totals (Runtime and volume parameters, as well as stored data) after confirming Yes or No.

Refer to 4 for details on collecting data from the sampler.

3.5.2.1 [Clock Menu](#)

The Clock Menu sets the HiVol clock. Note that times should be entered in 24-hour format.

Date

Set current date

Time

Set current time

3.5.2.2 Flow Alarm

The Flow alarm Menu allows the user to set the limits outside which a flow alarm is generated (only if outside these limits for more than 5 minutes). If either of the flow fields is set to 0 then the feature will be disabled. The flow alarm is sent out as a digital output on J2 terminal 12.

Max Flow

Set Maximum Flow

Min Flow

Set Minimum Flow

3.5.2.3 Major Fault

The major fault menu contains the controls for the HiVol restart. When the flow from a HiVol is insufficient for sampling purposes, resulting in an error (“Filter Blocked” or “Motor Drive Error or Major Blockage”) the instrument will stop sampling, then after a delay attempt to restart.

This resetting is controlled by the following fields:

Retry Delay

The number of minutes before the HiVol attempts a restart.

Max Retries

The maximum number of times to attempt retrying before giving up. When Max retries has been reached the operator must then visit instrument and repair the fault/change filter and hit the exit key.

No. Retries

Displays the number of retries that have occurred since everything was running fine. Once this number reaches that placed in the “Max Retries” field (above) the instrument will stop. When the instrument reaches the desired flow continuously for 5 minutes the “No. Retries” field will be reset to 0.

3.5.3 Manual Menu

Manual mode is useful for checking the flow-rate and verifying pump operation. The Manual Menu allows the HiVol to be switched on or off independent of other conditions such as programmable timer settings, wind speed and direction parameters. It is not intended for long-term sampling as it returns to Automatic mode after the time-out period. The time-out reverts to Automatic mode after a preset number of minutes, which can be set between 1 and 227 minutes.

Manual Mode

Set YES for Manual mode operation

Motor On

Once in Manual mode, set YES to turn pump motor on, or NO to turn it off.

Timeout

Timeout period in minutes, reverts to Automatic mode after this time.

Note: Setting the timeout out to 0 minutes will cancel timeouts and allow the HiVol to run indefinitely.

3.5.4 Calibration Menu

Start cal →

This Field will start the calibration as shown in 3.6.3



CAUTION

Do not place any objects on or in the circular hole on the top of the orifice plate. Any blockage can cause damage to the instrument and void warranty.

Calibration ensures that the values of various parameters indicated by the digital display (flow rate, temperature and barometric pressure) are representative of the true or actual flow rate through the sampler, and ambient temperature and pressure conditions. To comply with Australian or US EPA standards, regular flow rate calibration is required. The HiVol 3000 also has built-in temperature and barometric pressure sensors. Ambient temperature and barometric pressure calibration should also be carried out at regular intervals, which should form part of Quality Assurance procedures, along with other regular maintenance items.

A sample Field Calibration Record is included at the end of this manual.

3.6 Flow Rate Calibration

Note: Calibration of the HiVol samplers air flow rate measuring device shall be performed by the user after installation at a new site, following a site change, after significant maintenance or repair and in any event at intervals not exceeding two months, or as required by the regulatory authority.

The HiVol flow rate calibration is performed using a flow rate transfer standard, which mounts on top of the filter cassette. Flow rate transfer standards are typically top-loading Orifice Plates (as shown in figure 16), or electronic mass flow meters.

One simple method of calibrating the sampler is to use the optional Top-loading Orifice Plate (Part number: P-ECO-HVS3000-21) (This unit is specifically designed for the Ecotech HiVol samplers and each orifice plate has been calibrated against a certified reference standard. A manometer (water filled U-tube or digital) is connected to the orifice plate and gives a pressure drop across the orifice which is related to volumetric flow rate.

Note: The flow rate transfer standard (Orifice plate) must itself be calibrated against a traceable flow standard. According to Australian Standards, this should be done at least every 10 years, or sooner if damage or wear occurs. For top-loading orifice plates a roots-meter is commonly used for this primary calibration. Contact Ecotech for further details. It is imperative to take special care of the Orifice Plate and to inspect for damage before each use.

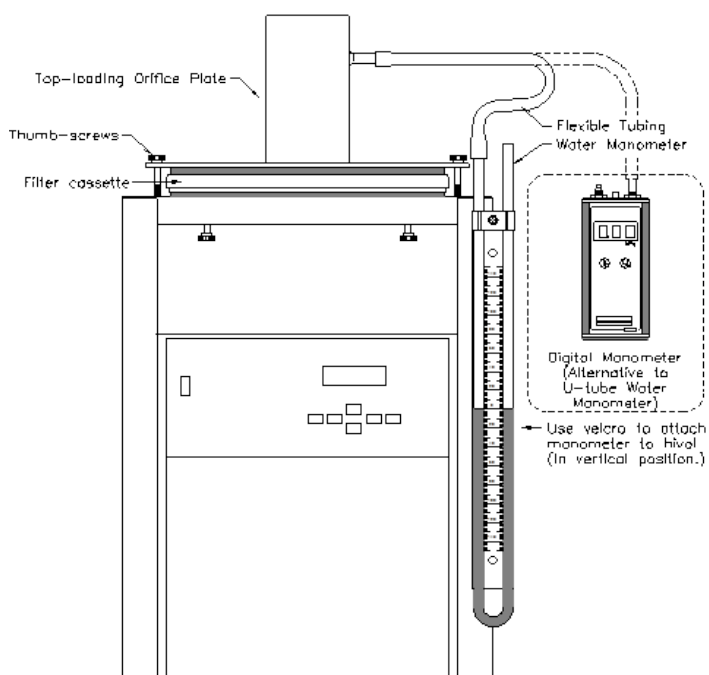

Figure 7 – Calibration set-up

3.6.1 Flow Rate Calibration – Temperature and Pressure Corrections

Calibration of flow rate with an Orifice Plate requires consideration to be given to current ambient temperature and barometric pressure conditions. A certified thermometer and digital barometric pressure indicator are recommended to obtain this data at the site where the calibration is to be performed.

Alternatively, the current ambient air temperature and pressure may be obtained from a local weather bureau. The average barometric pressure can be estimated from the altitude of the site either from altitude-pressure tables or by reducing the sea level pressure by 1.18kPa for each 100 metres of altitude (valid up to ~1000m).

Ideally, the ambient conditions during calibration should reflect the average ambient conditions during a typical sampling period. This will minimise errors due to drift in the electronics. If possible, choose a time of day when the temperature and barometric pressure are reasonably stable.

Note: Calibration of the HiVol 3000 is independent of the reference (STP) conditions, which are used only to calculate the corrected sample volume.

3.6.2 Using the Calibration Chart for Top Loading Orifice Plate

To obtain the data required to calibrate the HiVol air sampler, refer to the “Calibration Chart for Top Loading Orifice Plate”, supplied with the Orifice Plate. This chart eliminates the need for calculations.

For the HiVol 3000, use only the chart that says “USE FOR AMBIENT VOLUMETRIC FLOW DETERMINATION” in the top left corner. This chart is single sided.

Note: Earlier charts were double sided and apply to mass flow controlled HiVols such as the Model 2000. Do not use this chart for the HiVol 3000. These charts refer to 0°C or 25°C REFERENCE TEMPERATURE in the top left corner.

Obtain the ambient air temperature, to the nearest 5°C using a reference thermometer, and barometric pressure, to the nearest kPa (or 10 mbar) using a reference barometric pressure sensor (barometer). The temperature and barometric pressure displayed on the HiVol 3000 display should not be relied upon for this purpose.

Refer to the “Calibration Chart for Top Loading Orifice Plate”, supplied with the Orifice Plate. Locate the closest ambient temperature across the top edge of the chart, and the closest barometric pressure down the left-hand side of the chart.

Read down and across to obtain the current calibration data where the two intersect. An example is indicated with an “X” on the chart at 20°C and 96 kPa.

The data are in the following format:

Table 5 – Data displayed

Display reading on HiVol	Corresponding Manometer reading (U-tube Water Manometers)	Corresponding Manometer reading (Digital Manometers)
Display Flow m ³ /hour	ΔH mm H ₂ O	ΔH kPa
50	77	0.75
60	110	1.08
70	150	1.47
80	196	1.92
90	248	2.43

Note: ΔH Values shown in the above table are indicative only and will vary from one calibration plate to another.

If during calibration the ambient temperature and pressure are outside the range of the chart, the following formula may be used to calculate the pressure drop across the orifice plate for any flow-rate within the range of the sampler:

$$\Delta H = \left(\frac{Q_{DISPLAY}}{c} \right)^2 \times \frac{P_a}{T_a}$$

where

- ΔH = the difference in the level of water in the two manometer tubes (mm of H₂O)
- $Q_{DISPLAY}$ = the volumetric flow-rate reading on the air sampler digital display (m³/hour)
- P_a = the ambient pressure (in kPa)
- T_a = the ambient temperature (in degrees Kelvin)
- c = orifice constant given on Calibration Chart (for the particular orifice plate being used)

Eg. If the ambient temperature is 20°C (293K), ambient pressure is 100.8 kPa, and the orifice plate constant is 3.158, then the equation becomes:

$$\Delta H = \left(\frac{Q_{DISPLAY}}{c} \right)^2 \times \frac{P_a}{T_a}$$

First point (60m³/hour):

$$\Delta H = \left(\frac{60}{3.158} \right)^2 \times \frac{100.8}{293}$$

$$= 124mm$$

Second point (70m³/hour):

$$\Delta H = \left(\frac{70}{3.158} \right)^2 \times \frac{100.8}{293}$$

$$= 169mm$$

Third point (80m³/hour):

$$\Delta H = \left(\frac{80}{3.158} \right)^2 \times \frac{100.8}{293}$$

$$= 221mm$$

Note: The chart gives the same results and saves calculating each point.

The principle of flow rate calibration is that the air sampler displays a flow-rate, then the user adjusts the motor speed until the manometer reads the corresponding pressure drop (from the chart). The user then allows time for the signal to stabilise, then “locks-in” the point. This procedure is repeated at three flow rates – 60, 70, 80m³/hour. The HiVol then automatically fits a mathematical curve to the three points and the flow rate calibration is complete.

The HiVol 3000 uses three-point flow rate calibration, at 60, 70 and 80m³/hour. Points 50 and 90 can be checked (but not adjusted) after calibration, if required. The zero flow-rate point is not used as a calibration point in the HiVol 3000.

The three-point calibration ensures accuracy at any point within the range of the sampler. The HiVol fits a quadratic curve to linearise the signal to display conversion automatically. The flow-rate may be changed to a flow-rate other than the calibration flow-rate without introducing non-linearity errors.

After calibration of the HiVol, the flow rate indication should be checked at a minimum of 3 flow rates spaced over the range 61 to 75 m³/hour to comply with US EPA requirements.

3.6.3 Flow Rate Calibration Procedure

1. Where an Orifice Plate is being used to calibrate the HiVol 3000, use the Calibration Chart supplied with the Orifice Plate to obtain the manometer pressures, *H (mm of H₂O or kPa), at the three flow-rate used for calibration – 60, 70, 80m³/h.
2. Raise the inlet hood. Remove the filter from the filter cassette then install the orifice plate on top of the cassette. The assembly is fastened with two thumb screws, one on either side of the filter cassette.
3. Firmly finger tighten the two thumb screws to ensure a good seal (without bending the plate). Connect a U-tube water manometer to the port on the side of the orifice plate, with a length of flexible tubing. If necessary, add or remove water or slide the tube up and down until the water sits level in the tube and reads zero. See figure 16. Alternatively, a digital manometer may be used in place of the water manometer.

Note: Ensure the thumb screws are tightened firmly as the failure to do this will result in leaks through the seal and an invalid calibration.

4. Make sure there are no leaks between the sampler and orifice plate. Check that the flexible tube is connected securely.
5. From the Main Screen, go to the Main Menu → Calibration Menu → Start Cal then press Enter. The HiVol motor will automatically start up. Allow at least 5 minutes for the sampler to warm-up.
6. Use the arrow keys to go to the second line: MOTOR ADJUST. Press Select and the cursor will appear under ADJUST. Use the Up and Down arrows to adjust the motor speed until the manometer indicates the pressure that corresponds to the flow rate indicated on the first line. Allow the manometer a few seconds to stabilise between each adjustment.

Note: The HiVol remembers each point from previous calibrations so that the required adjustments are minimised.

7. Press Enter once the manometer is at the correct value. Now wait a few moments while the Flow Signal stabilises.

Note: The display will automatically indicate the amount of signal in Volts from the flow sensor. The actual value is not important but must be allowed to stabilise before selecting “Point x Done”.

8. Allow at least 30 seconds, then use the arrow keys to go to the bottom line “Point x Done”. Press Select and Enter. The second point will be displayed.
9. Repeat the previous three steps for the next two flow rates, using the new manometer readings. Each time, allow time for the signal to stabilise.
10. If the Exit key is pressed during calibration, the Manual mode is enabled which prompts the user that the HiVol calibration was not completed successfully.

11. Turn the sampler off and remove the orifice plate. The flow rate calibration procedure is complete.
12. If required, check the calibration at the operating flow rate. Use Equation 8-1 to calculate the corresponding *H pressure at flow rates other than those given on the chart. This is best done in the Manual menu rather than the Calibration menu.

Note: If you decide to re-check the flow rate calibration by going through the Calibration procedure again, always allow time for the flow rate signal to stabilise at each point, before selecting “Point x Done”.

3.7 Calibration of Temperature & Pressure Sensors

Check the temperature and pressure calibration at least every six months or when the barometric pressure or temperature data are suspect.

It is best to calibrate the pressure sensors with the blower motor not running and the temperature sensor with it running. Conditions should also be reasonably stable to prevent sudden environmental changes affecting calibrations. Refer to the calibration sheet for factory-calibrated values – these are different to the default values.

To change any of the calibration coefficients, it will be necessary to access the Hidden Menu. Refer to the Hidden Menu section for further information regarding accessing the calibration coefficients.

3.8 Temperature Sensor Calibration

1. Ensure blower motor is running with no filter installed in the cassette
2. Record the temperature displayed by the HiVol.
3. Record the actual temperature with a certified precision thermometer. If these measurements are significantly different, continue with the calibration as follows:

Calculate $x = \frac{\text{Actual temperature}}{\text{HiVol temperature}}$

4. Then:

Assign...	...the value of...
Temp coeff 2	$(\text{Temp coeff 2}) \div x^2$
Temp coeff 1	$(\text{Temp coeff 1}) \div x$
Temp coeff 0	Do not change

5. Repeat steps 1-4 (if necessary) until the HiVol temperature is close to the actual temperature.

3.9 Barometric Pressure Sensor Calibration

1. Record the barometric pressure displayed by the HiVol.
2. Record the actual barometric pressure with a certified pressure gauge or barometer. If these measurements are significantly different, continue with the calibration as follows:
3. Calculate the difference between the two values and adjust the barometric pressure coefficient 0 (Pres. coeff0) by this value. If the HiVol is reading high, decrease the value of the coefficient 0, and vice versa. Do not adjust coefficient 1 (Pres. coeff1).
4. Re-check the HiVol barometric pressure reading

3.10 Calculations

The HiVol 3000 flow-controller regulates the volumetric flow-rate of air when the pump is operating. In-built temperature and barometric pressure sensors collect ambient data, which are stored in the internal data logger. The HiVol 3000 uses the temperature and pressure data to determine the density of the gas.

All current data can be viewed in the Status menu. Historical data can be downloaded to a laptop computer via the serial port.

Note: Once the internal data logger memory is full, the HiVol stops collecting data. If the sample pump is still operating when the memory is full, then use the current data in the Status menu to read the uncorrected sample volume in m^3 (Tot. Vol. m^3) or the Corrected sample volume in standard m^3 (Cor.Volume m^3).

Using the ambient and Reference temperature and pressure information, the sample volume is automatically corrected to Standard Temperature and Pressure (STP) conditions. The HiVol's internal data logger stores both uncorrected and STP corrected sample volume data in the internal memory. The sample volume data are used to calculate the mass concentration.

The mass concentration may either be reported at STP corrected conditions, or at actual ambient conditions by using the relevant sample volume data in the calculation. Refer to local reporting standards.

The STP Reference conditions have been factory set, but may be changed via the Setup menu.

Mass concentration data are generally reported in $\mu\text{g}/\text{m}^3$ referenced to standard temperature and pressure (STP). There are, however, different accepted values of STP.

Table 6 – Standard temperature and pressure

HiVol Setup menu parameter	Standard Temperature °C (K)	Standard Barometric Pressure mmHg
	Ref. Temp	Ref. BP
Australia, Europe	0°C (273.18K)	760
USA	25°C (298.18K)	760
Japan	20°C (273.18K)	760

Note: 760mmHg = 760Torr = 101.325kPa = 1 standard atmosphere.

3.10.1 Sample Volume

The sample volume is automatically calculated and stored/updated in the HiVol. It is also automatically corrected to STP conditions and stored/updated in the HiVol.

3.10.2 Mass Concentration Calculation

Mass concentration (MC) is calculated using the formula:

$$MC = \frac{W_f - W_i}{V}$$

where

W_f = Final mass of filter element

W_i = Initial mass of filter element

V = Sample volume, either corrected or uncorrected

Calculate the TSP, PM₁₀ or PM_{2.5} concentration (depending on the inlet being used):

$$TSP \text{ or } PM_x = \left[\frac{W_f - W_i}{V_{STP}} \right] \times 10^3$$

TSP = mass concentration of TSP µg/std m³

PM_x = mass concentration of PM_x µg/std m³

W_i = initial mass of filter, mg.

W_f = final mass of exposed filter, mg

10³ = conversion of mg to µg.

If the corrected sample volume is used, the units for the concentration are standard $\mu\text{g}/\text{m}^3$ referenced to standard temperature and pressure conditions (STP). If the uncorrected sample volume is used, the units for the concentration are $\mu\text{g}/\text{m}^3$.

This page is intentionally blank.

4. Downloading Data

Data are collected from the HiVol via the RS-232C serial port. The serial port is a 9-way female D-connector on the HiVol control panel. A weatherproof cover is fitted to the connector to exclude dirt and moisture. This cover should be removed only when a cable is connected to the port.

The serial port operates at 9600 baud, eight data bits, one stop bit, no parity. This cannot be changed.

Data can be downloaded using the Windows-based Airodis Demo Version supplied on USB key or with the Ecotech WinCollect program.

Note: If using WinCollect, the HiVol uses the same command protocol as a 9400 Data Logger, and WinCollect should be setup to communicate with a 9400.

4.1 HiVol Connection

Connect a standard 9-pin serial cable to this port. This cable is also known as a Serial Mouse Extension cable. (The cable pinouts are straight-through connected.) Connect the other end of the cable to your computer. If your computer has a 25 pin male serial port, you may need to use a DB9 M/DB25 F adaptor or the appropriate 9-pin to 25-pin cable. On newer computers without a serial port, a USB serial port device may be required.

4.2 Using Downloader Software

The Downloader software is supplied with the HiVol on the Utilities CD. The software may be installed on any PC type computer running Microsoft Windows 95, Windows 98, or Windows 2000. It will not run under Windows 3.x.

A laptop computer is a practical way of downloading the data from a HiVol that is in service in the field. If your laptop does not contain a serial port then a U.S.B. – serial adaptor should be used. It is highly recommended that the easysync U.S.B. – serial adaptor be used for this function as it has been widely tested with all Ecotech products, works effectively and can be purchased from Ecotech.

Installation

1. Close any programs that are running on the computer (visible in the Windows task-bar).
2. Put CD in the computers CD rom drive.
3. A window will appear called Software Utilities.
4. Click on the Install software button.
5. Within this new window select xVol Communicator.
6. Now follow the prompts and windows to install the program.
7. The downloader program will open automatically ready for use.

Operation

1. Click on the “Start” button.
2. Select “Programs”, then click on “xVol Downloader”.
3. The program will run and a window will appear.
4. The program is simple to use.
5. In the “Output file:” box, type the directory pathname and filename for the data file to be created.
6. Select Com port from pulldown menu. Do not select a port that says “(In Use)”.
7. Click on “Collect Data” button.
8. The data will be collected. After a few seconds, a box will appear asking whether you want to clear the data from the HiVol memory. If this box does not appear, change the filename or delete the partially created file, then try again (previous step).
9. Select Yes or No. Selecting ‘Yes’ clears the data memory but not the Sample Total and Corrected volumes that are visible in the Status menu. To clear these, go to the Setup > Logger setup > Clear accumulator sub-menu.
10. The data should now appear on the screen.
11. To close program, click on the box (top right corner of the window).

The data will be stored in the directory and file specified. The data are separated by commas (the comma is called a delimiter). The data file may be imported into another program, such as Microsoft Excel, by specifying that the data are delimited, using comma delimiters. Using this method, the data will be formatted into individual cells.

The data are presented in the following format:

Report Date Time, Barometric Pressure (mmHg), Ambient Temperature (°C), Wind speed (m/s), Wind direction (°), Sigma Theta (standard deviation for wind direction), Rainfall (bucket tips), Flow-rate (m³/h), Corrected accumulated sample volume (standard m3), Uncorrected accumulated sample volume (m³).

Note: Wind direction average data will be zero if there has been no wind speed data for the entire averaging period.

If the data file already exists, any further downloading of data will be appended to the existing data in that file. If the data file does not exist, the Downloader software automatically creates the file.

Note: The Windows regional settings for time and date format should be set the same on the computer used to download the data and the computer used to process the data (if different computers are used.) The settings are located in the Windows menu system under Start, Settings, Control Panel, Regional Settings, Time and Date.

4.3 Communicating with the HiVol (Alternative Method)

An alternative (more complicated) way of downloading data is to use a terminal emulator. Send *****EA** command, then use terminal to download file using X-modem. Using this method the data will be in hexadecimal format and will need to be converted to ASCII format.

If required, it is possible to connect a modem to the HiVol to collect data. It is also possible to use a terminal program to communicate with the HiVol via the Serial port (RS-232C). This may be useful for remote interrogation or for connecting the HiVol to an external data logger.

Please contact Ecotech for optional modem installation.



Figure 17– HiVol serial port (RS-232C)

This page is intentionally blank.

5. Maintenance

Regular maintenance and inspections should be performed on the HiVol and associated equipment. Damage to the HiVol and electrical cord may jeopardise safety and cause potential fire hazards. Periodic statutory electrical safety checks are also required in most countries.

The HiVol sampler will normally spend its entire lifetime in the field exposed to the weather.

It is therefore important that the equipment is regularly inspected and maintained as this will assist in obtaining high quality data and reliable performance.

The frequency of cleaning and maintenance will depend on the site location and the sampling sequence selected for monitoring.

It is recommended that a plan is developed for regular maintenance and that any maintenance is recorded in the instrument log-book for the HiVol sampler.

A typical maintenance procedure for the Ecotech HiVol 3000 is contained in Table 7 – Maintenance schedule.

Note: The high volume sampler motor is equipped with sealed groove ball bearings, which do not need lubrication. The grease filling is sufficient for the whole service life of the bearings.

5.1 Maintenance Tools

To perform general maintenance on the HiVol 3000 the user will be required to carry the following equipment:

- Cloth
- Grease
- Dow Corning 316 Silicone Release Spray (or similar)
- Manometer
- #2 Philips-head screwdriver
- Knife
- Orifice plate

5.2 Maintenance Schedule

Table 7 – Maintenance schedule

Interval (samples)*	Item	Procedure	Page
Weekly	General Sampler components	Check	75
Weekly	Automatic Flow	Check	75
Weekly	Cassette	Clean	75
Weekly	SSI (PM ₁₀ or PM _{2.5})	Clean/Regrease	75
As Needed	Flow Sensor	Adjustment	77
As Needed	Flow Sensor	Replacement	78

* Suggested intervals for maintenance procedure may vary with sampling intensity and environmental conditions.

5.3 Maintenance Procedures

5.3.1 General Sampler Component Check

1. Check power cords for cracks, fraying, wear or brittleness, cuts or other damage.
2. Check tie-downs or attachment to fixed structure for security.
3. Inspect the filter holder and rubber gaskets*.
4. Ensure there is no damage to the inside or outside of the housing.

* When an exposed filter is removed from the cassette the particulate matter boundary should be clearly defined on the filter. If the boundary is diffuse or shows irregularities then the rubber gaskets may be leaking and require replacement.

5.3.2 Automatic Flow

1. Check operation of automatic flow compensation device by placing two filters in the filter cassette

5.3.3 Cassette

1. Clean the sampler and wipe the cassette and supporting structure with a damp cloth.

Note: Do not use solvents to clean plastic or rubber components, including labels, seals and electrical components.

5.3.4 Size Selective Inlet

The greased collection shim inside the size selective inlet must be periodically cleaned and regreased. To re-grease the collection shim, release the four catches that secure the plate and remove it from the size selective inlet. Wipe off the old grease before spraying with a thick coating of the correct grease.

Re-greasing of the greased collection shim located inside the size selective inlet should only be done using Dow Corning Silicone Release Spray (#316). Any other type of grease may affect the particle collection characteristics of the inlet and therefore should not be used.

When re-assembling the size selective inlet ensure that the hooks are aligned with the slots in the top section of the inlet.

It may be necessary to adjust the catch length periodically as the rubber seals compress.

Table 8 – SSI cleaning schedule

Maintenance Item	Frequency		
	Weekly	Quarterly* (Table 3)	Annually
Check the four inlet hook-catches for proper tension.	*		
Inspect all gaskets for wear and compression.	*		
Inspect and lubricate all catches.			*
Remove, clean and re-grease the collection shim	*		
Remove and clean the first stage plate.		*	
Clean all the internal surfaces with a damp lint-free cloth.	*		
Remove hood and clean the acceleration nozzles with a bottle brush. Wipe internal surfaces with a damp cloth.		*	

Note: If TSP (total suspended particulate) can be estimated from historical data to the site then Table 8 – SSI cleaning schedule, should be used as a guide to maintenance frequency of the size selective inlet, otherwise assume that TSP is twice the PM₁₀ concentration if PM₁₀ data are available.

Table 9 – TSP concentration and cleaning intervals

Average Estimated TSP at Site std $\mu\text{g}/\text{m}^3$	Number of Sampling Days	Interval, assuming 6-Day Sampling Schedule
40	30	6 months
75	15	3 months
150	10	2 months
200	5	1 month



Figure 18 – Application of grease

5.3.5 Flow Sensor Adjustment

It is possible that the flow sensor may need to be re-zeroed from time to time. This may be necessary if the HiVol is dropped during transportation, or for other reasons.

To find out if this adjustment procedure is required:

1. Calibrate the HiVol flow rate by carefully following the procedure in the User Manual supplied with the HiVol 3000.
2. During the calibration, record the average value of the three flow voltages (at 60, 70 and 80 m³/hour) from the HiVol display.
3. The average flow voltage should differ by approximately 0.3 Volts between 60 and 70 m³/hour and by approximately 0.3 Volts between 70 and 80 m³/hour.
4. The three flow voltages should be within the range 0.5V to 4.5V.
5. If the flow voltages are outside this range, the unit may not calibrate correctly – refer to table below.

Table 10 – Flow voltage values (examples of good and bad)

Flow	Good values	Bad values	Bad values
60 m ³ /hour	2.2V	2.20V	0.000V
70 m ³ /hour	2.5V	2.25V	0.000V
80 m ³ /hour	2.8V	2.30V	0.250V
		(much less than 0.3V between points = BAD)	(points outside the acceptable voltage range = BAD)

6. If this is the case, check that there are no leaks during the calibration. In particular, make sure the calibration plate is secured to the sampler with the thumb-screws provided and that the calibration plate is sitting flat.

5.3.6 Flow Sensor Replacement

5.3.6.1 Removing the Rear Panel

1. Switch off the power at the supply and remove the power connector from the side of the HiVol. The hinged inlet should be raised (or can be removed if necessary).
2. Using #2 Philips-head screwdriver, remove the two screws securing the rear panel (arrows shown in photo.) The panel will drop down slightly, allowing the base of the rear panel to be pulled outwards. The rear panel can then be carefully removed.



Figure 19 – Rear panel

3. Remove flow sensor using.



Figure 20 – Flow sensor

5.3.6.2 Refitting

1. Refit components in the reverse of the removal sequence.
2. When replacing the flow sensor , push the tubing against the fittings to ensure a good seal.
3. If necessary, apply good quality electrical insulation tape to the coupling between the Inlet pipe and the Inlet Funnel. Start with the tape around the pipe (at least 2 full turns) then continue to wrap the tape at least 2 full turns around the join, and finally 2 full turns around the Inlet Funnel, stretching the tape slightly as you go to ensure a good seal.
4. Tighten the Pipe Clamp on the Inlet Funnel. The tape provides the seal and the Pipe Clamp ensures the tape stays in position. Do not over-tighten the pipe clamp.



Figure 81 – Pipe clamp

5. Ensure all seals are good, then recalibrate the HiVol according to the procedure in the User manual. Depending on the Zero Flow flow voltage adjustment, the Flow Voltages during calibration should be in the order of:

60 m³/hour: 1.8-2.4V

70 m³/hour: 2.2-2.8V

80 m³/hour: 2.5-3.3V

If not, then you need to check for leaks.

6. Finally replace the rear panel.
7. Test the sampler for correct operation.
8. If necessary, take the HiVol out of Manual mode. Go to the Main Menu>Manual menu, then set Manual Mode to NO. Hit Exit to return to the Main screen.

5.3.7 Hidden Menu

The Hidden Menu is used to set parameters at the factory. It is not usually necessary to access the Hidden Menu.

Table 11 – Hidden menu

Test Menu	→	Diagnostics only
Voltages	→	Diagnostics only
ID	0	Enter a HiVol identification number
Date Format	1	0=mm/dd/yyyy (USA) 1=dd/mm/yyyy (common) 2=yyyy/mm/dd (Japan) dd: day, mm: month, yyyy: year
Flow coeff0	-2.62	Flow calibration coefficient 0
Flow coeff1	24.18	Flow calibration coefficient 1
Flow coeff2	1.95	Flow calibration coefficient 2
Temp coeff0	0.381	Temperature calibration coefficient 1
Temp coeff1	0.0192	Temperature calibration coefficient 2
Temp coeff2	0.0007	Baro. pressure calibration coefficient 0
Pres. coeff0	73.	Baro. pressure calibration coefficient 1
Pres. coeff1	168.7	Wind speed calibration coefficient 0
WS coeff0	0	Wind speed calibration coefficient 1
WS coeff1	0.7989	Wind direction calibration coefficient 0
WD coeff0	0	Wind direction calibration coefficient 1
WD coeff1	79.1	Power up voltage
Min 12V	12.	Resets all hidden menu parameters!
Default Prms	→	Rain gauge or Wind sensor selection
0=RG, 1=WS	1	Factory setting – do not adjust.
Inst. Type	1	

* Power down voltage is 90% of power up voltage value.

To access the Hidden Menu, hold down the secret key (the first letter C in the ECOTECH logo), then press the Select key at the same time.

This page is intentionally blank.

Appendix A. Noise Test

Manufacturer's Noise Test Model: HiVol 3000 High-Volume Air Sampler

HiVol 3000, muffler (production), TSP inlet

This report shows the effect of installing a muffler as noise reducing method to the HiVol 3000. The tests have not been performed in an anechoic chamber. They were performed in an area surrounded by concrete walls at a distance of about 5m from each side. The floor surface was concrete.

- Hivol sound level checks at 3m (20/07/02)
- Using Delta Ohm Integrating Sound Level Meter Model HD9020
- Meets IEC 821 & 651 Type 1
- All measurements in dB(A), Front / Rear /Outlet side
- All measurements averaged at 3m per EPA requirements
- Background 48dB(A)

Effect of muffler on test unit

Without muffler: 55dB(A) front and rear, 67dB(A) exhaust side

With muffler: 54dB(A) front and rear, 60dB(A) exhaust side

This page is intentionally blank.

Appendix B. References

5.4 Australian Standards

AS/NZS 3580.1.1:2007 Ambient Air – Guide for the siting of sampling units

AS 3580.9.3:2003 Methods for sampling and analysis of ambient air

Method 9.3: Determination of suspended particulate matter - Total suspended particulate matter (TSP) – High volume sampler gravimetric method

AS 3580.9.6:2003 Methods for sampling and analysis of ambient air

Method 9.6: Determination of suspended particulate matter – PM₁₀ high volume sampler with size selective inlet - Gravimetric method

5.5 US EPA Standards

40 CFR Parts 50,51, 52,53 and 58.

Reference Method for the Determination of Suspended Particulate Matter in the Atmosphere (High-Volume Method).

Reference Method for the Determination of Particulate Matter as PM₁₀ in the Atmosphere.

5.6 British Standards

BS EN 12341:1999

Air Quality – Determination of the PM₁₀ fraction of suspended particulate matter – Reference method and field test procedure to demonstrate reference equivalence of measurement methods.

This page is intentionally blank.

Appendix C. Accessories

Table 12 – Accessories

Part Number	Basic Instrument
ECO-HVS3000	HiVol 3000 High Volume Air Sampler Choose sample inlet from below Note: All configurations are 200-240 VAC 50/60 HZ unless otherwise requested
Part Number	Spare Size Selective Inlets
ECO-HVS3000-01	Total Suspended Particulates Sample Inlet
ECO-HVS3000-02	PM ₁₀ Size Selective Inlet
ECO-HVS3000-03	PM _{2.5} Size Selective Inlet
Part Number	Calibration Sets (Contact Ecotech for further details)
ECO-HVS3000-21	Calibration Orifice Plate for HVS3000 High Volume Air Sampler Choose manometer and other items as required from below
ECO-HVS3000-22	Transport case for field calibration equipment Note: Does not fit the U tube manometer
ATM-1000	300 mm U Tube Manometer
ECO-HVS3000-24	Battery Operated Digital Manometer
ECO-HVS3000-25	Battery Operated Digital Barometer
H030095	1 x 0-50 deg. C Max/Min Mercury Thermometer
ECO-HVS3000-27	1 x Digital Thermometer
Part Number	Filters
ECO-200010	100 x PTFE 200mm x 250mm Pallflex Filters
ECO-2000030-4	Pure Quartz Product P/No. 2500 QAT 203 x 254 mm, qty 25 filters per box
Part Number	Wind Direction Sampling Options
ECO-HVS3000-40	Wind Speed/Wind Direction Sensor (Model 034B) Includes Sensor, mounting support and 1.7 metre cable
Part Number	Other Accessories
ECO-HVS3000-51	Muffler for High Volume Air Sampler (Silencer)
ECO-HVS3000-52	Spare Filter Cassette

This page is intentionally blank.

Appendix D. " Field Operation Checklist

- Site meets the relevant siting criteria for jurisdiction in which monitoring are to be performed.
- Electrical connections and earth leakage circuit breaker have been installed and checked.
- Sampler has been securely fastened to supporting structure.
- When using the optional SSI, the impaction shim has been greased and installed in the size selective inlet.
- Field calibration has been performed and flow rate meets the inlet design flow rate requirement.
- A pre-weighed filter has been installed and details including the initial flow rate have been recorded in an appropriate log sheet.
- STP reference conditions have been entered in the Set-up Menu.
- The sampler timer has been programmed for the required start-time and sampling duration.

This page is intentionally blank.

Appendix E. High Volume Air Sampler Filter Papers Custody Record

LAB:

Sent (date): _____ Time: (24 hour): _____

By (name): _____ Signature (of sender): _____

Filter ID's: _____

Field Technician: _____

Company (name): _____ Project: _____

Name: _____

Location: _____ Received (date): _____ Time: (24 hour): _____

By (name): _____ Signature (of receiver): _____

Filter ID	Condition	Filter Run Date	Change Date	Initial Run Time ⁺	Final Run Time ⁺	Initial Flow [Nm ³]*	Final Flow [Nm ³]*	Total Volume [Nm ³] (Only HVS-3000)	Corrected Volume [Nm ³] (Only HVS-3000)	Changed by	Signature

LAB:

Received (date): _____

Time: (24 hour): _____

By (name): _____

Signature (of Receiver): _____

Filter ID	Condition (good/damaged)	Observations

This page is intentionally blank.

Appendix F. HiVol Field Calibration Record

SITE LOCATION:	HIVOL ID/SERIAL #:	DATE LAST CALIBRATED:
CALIBRATION DEVICE SERIAL #:	CALIBRATION DEVICE CONSTANT (c):	CALIBRATION DEVICE DATE CALIBRATED:

Date	Time	Operator	Ambient temperature (deg.K)	Ambient pressure (kPa)	Calibration flow-rate	ΔH , mm Manometer	Post Calibration Check	ΔH , mm Manometer	Comments & maintenance performed
					60		60		
					70		70		
					80		80		
					60		60		
					70		70		
					80		80		
					60		60		
					70		70		
					80		80		

Date	Time	Operator	Ambient temperature (deg.K)	Ambient pressure (kPa)	Calibration flow-rate	ΔH , mm Manometer	Post Calibration Check	ΔH , mm Manometer	Comments & maintenance performed
					60		60		
					70		70		
					80		80		
					60		60		
					70		70		
					80		80		
					60		60		
					70		70		
					80		80		
					60		60		
					70		70		
					80		80		

This is a suggested format only – photocopy form prior to use if needed.

This page is intentionally blank.



acoem.com

User manual subject to change without notice. Images used are for illustrative purposes only.
All trademarks and registered trademarks are the property of their respective owners.
© 2022 Acoem and all related entities. All rights reserved.