



# TSCU-R

## Tunnel Sensor Control Unit Rugged Version

TSCU-R is a central control unit, designed for installation and operation with compatible Tunnel Sensors instruments, such as VICONOX, AIRFLOW, and CROSSFLOW, within the tunnel environment itself.

All Tunnel Sensors instruments include a comprehensive range of output and communication options, allowing them to integrate with tunnel systems independently. However, in many applications there is a requirement for multiple instruments to interface with the tunnel through a common control unit, such as TSCU-R.

TSCU-R can connect with up to eight Tunnel Sensors instruments on a common RS485 communications bus, gathering and collating all the available instrument readings and data, in real time, using a single “daisy-chain” cable connection.

It can then present the gathered data to the tunnel SCADA or ventilation control system, using a range of on-board interface options including: isolated and scalable analogue outputs; programmable volt free relays; and Modbus RTU serial communications. All TSCU-R outputs can be mapped to any of the available instruments / parameters.

Two multipole bulkhead connectors provide power and comms in a format that allows pre-terminated instrument cables (available separately) to be used to quickly and easily connect up to two local instruments in a “plug and play” fashion. This is particularly convenient in the common gas / vis / flow monitoring configuration that typically requires two instruments to be installed alongside each other at a common location. These dedicated instrument connections avoid the need for separate PSU's and junction boxes etc., as well as significantly reducing installation time and wiring complexity.

TSCU-R is designed to be mounted within the tunnel bore itself, but at a level and location that is more easily accessible than most instrument installations, so that operators can gain access to it more readily.

An external USB connection allows operators to directly connect a laptop PC (running the supplied Utility software) to the TSCU-R, which then allows the operator to interrogate and control not only the TSCU-R itself, but also any connected instrument. This “walk up comms” feature is of great benefit during installation, commissioning and servicing.

Over-Voltage Protection (OVP) is offered as standard on the AC power supply and Modbus RTU connections, providing increased protection against voltage spikes and transient voltages. This helps protect not only the TSCU-R itself, but also any power connected instruments at the same location.

Some versions of the TSCU-R include additional OVP for analogue output connections, which further protects the unit against transient voltages induced in connected cables. The TSCU-R enclosure is manufactured from 316L stainless steel and achieves an IP67 protection rating, so it's well protected against the harsh tunnel environment.

The enclosure has been designed to be mounted against a wall, or other vertical surface, using four slotted mounting lugs that allow the unit to be fixed or removed easily. The enclosure lid employs a closed cell silicone sponge gasket for sealing, quick release catches, and a security lock nut to prevent unintended access.

Internal wiring connections are all clearly marked on industry standard DIN rail screw terminals. Internal labelling, detailing the wiring connections, is provided for quick reference and ease of installation.

Note that the OVP modules are sacrificial and that in protecting the TSCU-R and its connected instruments from an over-voltage event, individual OVP modules may be damaged and require replacement. However, all OVP modules are available from Acoem Dynoptic and are easily replaced on site.

The TSCU-R is available in seven variants which, between them, provide varying numbers of analogue outputs and relay contacts, as well as the option for additional OVP protection. These variants are summarised overleaf.

## Benefits

- Connect up to 8 instruments on a single RS485 daisy-chain connection
- Dedicated connectors, with power, for 2 local instrument connections
- Programmable digital outputs
- Enhanced over-voltage protection
- Isolated RS485 (Modbus RTU) output
- Isolated analogue outputs
- External USB and free PC software
- IP67 ingress protection
- IP67 ingress protection
- Clearly marked DIN rail screw terminals

Model	Analogue Qty.	Relay Qty.	Analogue OVP	Modbus OVP	AC OVP
TSCU-R-0	0	0		✓	✓
TSCU-R-4	4	4		✓	✓
TSCU-R-8	8	8		✓	✓
TSCU-R-12	12	12		✓	✓
TSCU-R-4-OVP	4	4	✓	✓	✓
TSCU-R-8-OVP	8	8	✓	✓	✓
TSCU-R-12-OVP	12	12	✓	✓	✓

## Example “Parent” Configuration Diagram:

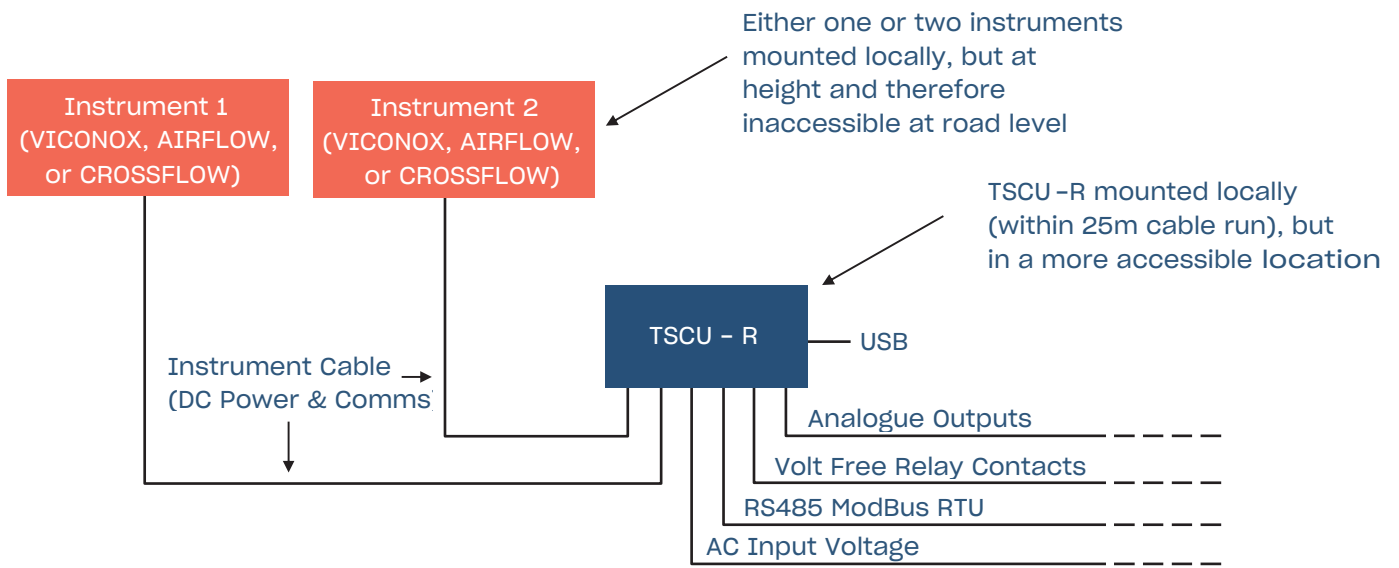

## Example “Manager” Configuration Diagram:

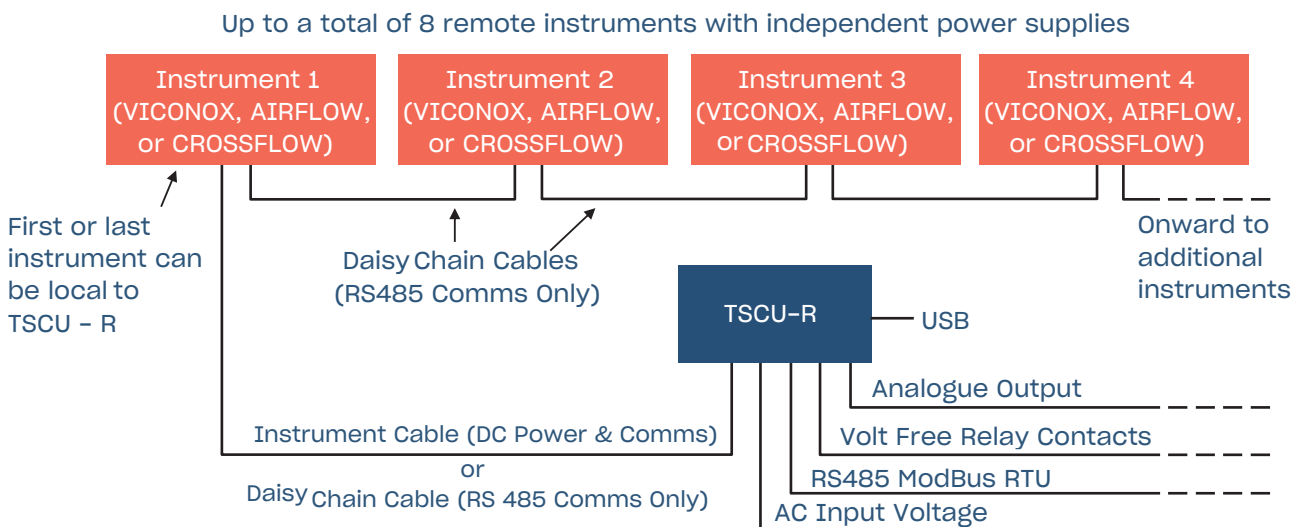

## Specification

### Instrument Interface

Item	Parameter	Units	Min	Max	Comment
1	Connected Instruments			8	RS485 serial bus comms. connection only
2	Instruments Powered by TSCU-R			2	24Vdc power and serial bus comms.
3	Connection Cable Length	km		1	Comms. only. Total daisy-chain length.
4	Connection Cable Length	m		25	Power and comms. to each instrument

### Tunnel Interface

5	Serial Comms.			1	Modbus RTU via isolated RS485
6	Analogue Outputs			12	Options for 0, 4, 8, or 12 analogue output channels
7	Analogue Output Current	mA	0/2/4	20	Isolated, scalable and programmable
8	Volt Free Relay Contacts			12	Options for 4, 8, or 12 relay contacts
9	Volt Free Relay Contacts Current	A	0	1	@ 30Vdc. Programmable.
10	USB			1	Pass through to all connected instruments

### Power

11	AC Supply Voltage	Vac	85	264	Nominal 100–240Vac.
12	AC Supply Frequency	Hz	47	63	Nominal 50–60Hz.
13	AC Supply Current	A	1.4		
14	AC OVP Limit	Vac		264	Standard
15	RS485 (ModBus) OVP Limit	Vac		12	Optional OVP version
16	Analogue Output OVP Limit	Vac		24	Optional OVP version
17	Terminal Wire Gauge	AWG	24	12	
18	Terminal Wire Conductor Area	mm <sup>2</sup>	0.2	2.5	
19	Cable Gland Quantity			5	
20	Cable Gland Size	mm	6	12	Acceptable cable diameter. Thread: M20

## Physical

Item	Parameter	Units	Min	Max	Comment
21	Ingress Protection			IP67	
22	Operating Temperature	°C	-40	+50	
23	Operating Humidity	%		100	
24	Materials				AISI/SAE 316L stainless steel
25	Dimensions	mm	375 x 246 x 145		
26	Weight	kg		6	

## Compliance & Design

27	Design Life	Years	20		
28	MTBF	Hours	100,000		
29	Warranty	Months	24		Return to base warranty. Extensions available

Dimensions (mm):

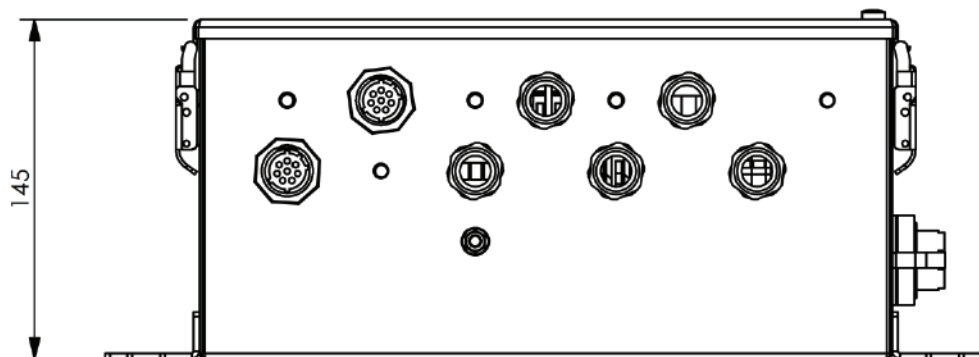
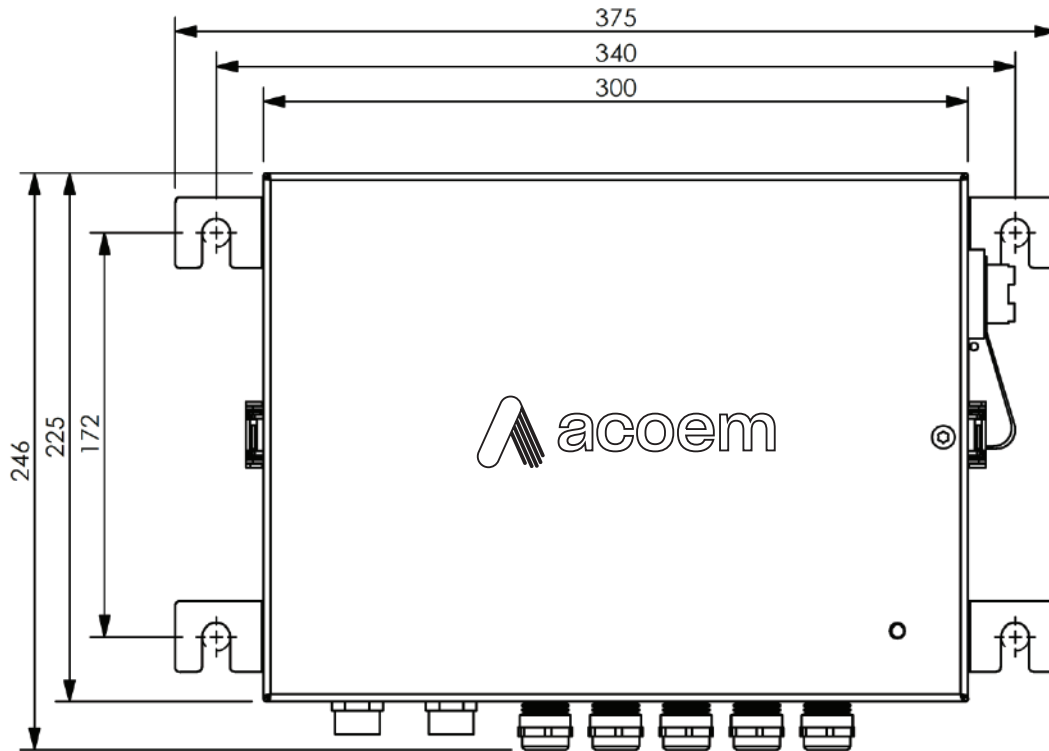

## Options & Accessories:

Description	Order Code	Notes
 <p>TSCU-R Variants</p>	TSL-TSCU-R-0	0 analogue / digital outputs
	TSL-TSCU-R-4	4 analogue / digital outputs
	TSL-TSCU-R-8	8 analogue / digital outputs
	TSL-TSCU-R-12	12 analogue / digital outputs
	TSL-TSCU-R-4-OVP	4 analogue / digital outputs with OVP
	TSL-TSCU-R-8-OVP	8 analogue / digital outputs with OVP
	TSL-TSCU-R-12-OVP	12 analogue / digital outputs with OVP
 <p>Cable Assemblies</p>	CBL-185	5m instrument cable (power & comms)
	CBL-186	10m instrument cable (power & comms)
	CBL-187	15m instrument cable (power & comms)
	CBL-188	20m instrument cable (power & comms)
	CBL-189	25m instrument cable (power & comms)

Note that the actual part may differ from the above representative pictures.

