



*Visibility measurement using established forward scatter principles for compact design and extended measurement range*

*Present weather monitoring using exclusive backscatter sensor gives unparalleled ability to identify frozen precipitation*

*Wide range of applications from aviation to road weather and national weather service networks*

## KEY FEATURES & BENEFITS

- Wide measurement range 10m to 75km
- WMO 4680 present weather codes
- Compact forward scatter design
- Window contamination monitoring and compensation
- Direct connection of the ALS-2 Ambient Light Sensor for use in Runway Visual Range (RVR) applications
- Digital, analogue and switching relay outputs
- Comprehensive self-test and maintenance data
- 3 Years warranty

The SWS-200 is the sensor of choice where extended visibility range measurement combined with reliable present weather identification in a compact package is required. The use of a backscatter receiver, exclusive to Biral, significantly improves the accuracy of present weather reports especially when distinguishing frozen from liquid precipitation. The SWS-200 is easily integrated into monitoring and logging systems using the serial communication interface whilst analogue output options and alarm relays can be used for legacy systems and activation of local warnings.

## Visibility & Present Weather Measurement

The measurement of visibility by forward scatter as used by the SWS-200 is now widely accepted and seen as having significant advantages over more traditional techniques such as the use of transmissometers or backscatter sensors. Backscatter sensors share the SWS-200's advantage of being compact however, the backscatter signal is strongly dependent on the type of obstruction to vision resulting in poor accuracy and limited upper range. Transmissometers were once considered the standard method of visibility measurement due to their direct measurement of visibility. However, their limited measurement range, high cost of acquisition, large size and significant maintenance costs have resulted in their use being limited to a few specialist applications. The SWS-200 by contrast is

compact, requires little maintenance and has a visibility range of 10m to 75km, whilst its measurement performance is proven to be comparable to that of a transmissometer. The calibration of the SWS sensor family was undertaken in accordance with the recommendations of ICAO 9328 and is traceable to a national weather service transmissometer.

Forward scatter sensors are able to determine precipitation type by observing the intensity of scattered light and the transit time for each precipitation particle as it passes through the sample volume. These parameters are used to estimate the particle size and determine if it is liquid or frozen using well established relationships, unfortunately in anything other than still conditions the relationships become unreliable, resulting in poor classification accuracy. Biral sensors are the only ones to solve this problem through the use of a backscatter receiver. The ratio of forward to backscatter is significantly different for liquid and frozen particles, allowing the SWS-200 to report the correct precipitation code reliably even in the most challenging conditions. Accurate reporting of precipitation type, especially the ability to discriminate liquid from frozen precipitation, is very important in many applications and especially important in aviation.

## Applications

### Aviation

Airports need to monitor visibility across the airfield to ensure the safety of taxiing aircraft, for Runway Visual Range (RVR) calculation and for transmission to aircraft as part of the METAR. The SWS-200 can fulfil all of these roles and also provides present weather information for inclusion in METAR reports.



*Suitable for a range of applications.*

### National Observation Networks

Whilst the models used for forecasting continue to improve there remains a need for accurate measurement of current weather conditions to provide the model's input. Improvements to forecast accuracy can also be gained by increasing the number of monitoring sites but there is always a trade-off between forecast quality and cost. The accuracy and repeatability of the SWS-200's visibility and present weather measurements combined with its ability to be deployed in large numbers make it an attractive solution for national weather services.

### Road Weather Information Systems

Road Weather Information Systems (RWIS) monitoring sites often use lower specification sensors with the addition of a

simple visibility sensor. More recently the demands of increasing traffic flows and the economic impacts of congestion has led to the use of higher specification sensors and the reporting of present weather conditions. The roadside is an unusually harsh environment with corrosive chemicals and spray from passing vehicles to contend with. The ability of the SWS-200 to correct for window contamination whilst reporting the build-up of dirt as part of its data message allows roadside maintenance to be kept to a minimum whilst preserving system performance.

### Wind Turbines

The SWS-200 is used in many other applications including weather stations and the control of aviation obstacle light intensity on wind farms. When wind turbines are concentrated together their warning lights can constitute a significant nuisance to local residents, the SWS-200 allows the intensity of the light to be reduced in conditions of good visibility reducing the impact on the wind farm's neighbours. The measurement accuracy and extended range offered by the SWS-200 are important factors in their selection for this role, whilst the present weather capability offers the wind farm operator additional information that can be used to protect the turbine from adverse weather conditions.

## Interfacing, Connectivity and Cost of Ownership

The SWS sensor family is designed for easy installation by a single person and has an interface which simplifies system integration. The ASCII text data message is transmitted at user defined time periods or in response to a polled request using a RS232, RS422 or RS485 interface. The standard data message provides averaged and instantaneous Meteorological Optical Range (MOR) along with present weather codes according to WMO Table 4680. An optional interface to the ALS-2 Ambient Light Sensor simplifies use in aviation applications where both METAR and RVR information is required. The ALS-2 Ambient Light Sensor data is appended to the standard sensor data message simplifying both installation and data processing.

To allow connection to older legacy systems the visibility measurement is available as an analogue voltage or optionally as a 4-20mA current. Three volt free contact change over relays offer user configurable outputs including visibility threshold, precipitation or snow detection and sensor fault.

### Advanced Diagnostics

To keep track of the operational status of the sensor abbreviated self-test information is included in every data message with a full self-test report available on request. Self-test features include window contamination monitoring which automatically corrects the output data and provides two stage warnings allowing maintenance to be performed most efficiently. Calibration checks and recalibration are simple and quickly accomplished in the field by a single person. The need for such procedures is limited however as the stability of the light source and receiver circuitry is such that recalibration intervals are typically measured in years.

The SWS-200 is DC powered with the capability to accept separate supplies for sensor electronics and the hood heaters. Hood heating is only required in regions where blowing snow is encountered. To conserve power the heaters are fully automatic and only operate when the temperature drops below 4°C.

## Sensor Configuration Information

For a detailed explanation of the configuration options please refer to the table below.

### 20 – SWS-200 Sensor

#### Hood Heating:

**HV** – With heating

**NH** – Without heating

#### Data Output:

**J** – Standard outputs

**K** – 0-20 mA as well as standard output

**L** – 4-20 mA as well as standard output

#### Self-Test and Monitoring:

**S** – Standard self-test and monitoring

**A** – Advanced self-test and monitoring

#### Cable Glands:

**PG** – Standard plastic cable glands

**MG** – Single metal cable gland

#### Ambient Light Sensor Interface (ALS-2):

**NA** – Without ALS-2 Interface

**WA** – With ALS-2 Interface

#### Precipitation Definitions:

**XX** – Country code

#### Configuration:

**RC** –Regular configuration

**SC** –Special configuration

20								
----	--	--	--	--	--	--	--	--

**Example:** 20.HV.J.A.PG.NA.UK.RC (Please use this code when ordering your sensor).

**Default visibility range: 10m to 20km.** If a different range is required please order a 'special configuration' (SC) and state the required range on your order from the options below:

10m to 10km  10m to 32km  10m to 50km  10m to 75km

## Configuration Options Explained

Option	Description
Heating Options	Heated hoods are available to stop snow from accumulating around the optical windows. The hood heating option is only required in regions where snow is experienced. Option <b>HV</b> : Hood heating included Option <b>NH</b> : No hood heating
Data Output	The sensor has RS232, RS422 and RS485 serial output capabilities as well as a 0-10V analogue output representing visibility (MOR) in the standard configuration. A current output is available as an option. Option <b>J</b> : Standard outputs Option <b>K</b> : Standard outputs plus 0-20mA Option <b>L</b> : Standard outputs plus 4-20mA
Self-Test & Monitoring	The sensor may be configured for either Standard or Advanced Self-Test. The standard self-test option provides monitoring of all the essential sensor functions and contamination of the transmitter window. The advanced self-test option adds receiver window contamination monitoring and receiver sensitivity monitoring. Monitoring of receiver contamination is useful in applications where different levels of contamination may occur on the sensor windows, for example where strong or gusty winds are experienced. Option <b>S</b> : Standard Self-Test Option <b>A</b> : Advanced Self-Test
Cable Glands	The sensor may be supplied with either four plastic cable glands or a single metal cable gland for user cable entry. The plastic glands accommodate cables from 3.5mm to 10mm Ø. The metal gland is suitable for cables from 9mm to 16mm Ø Option <b>PG</b> : Four plastic cable glands Option <b>MG</b> : Single metal cable gland
ALS-2 Interface	The sensor may be configured to allow direct connection of the ALS-2 Ambient Light Sensor. The Ambient Light Sensor is typically used in airport applications where Runway Visual Range must be calculated. Option <b>NA</b> : Without Ambient Light Sensor Interface Option <b>WA</b> : With Ambient Light Sensor Interface
Precipitation Codes	Biral present weather sensors report precipitation and visibility according to predefined intensity values. As no universal definition for intensity values is available, sensors can be supplied configured to the requirements of a range of countries or the customer may supply their own definitions. Where custom definitions are required please complete a Custom Present Weather Definition Form, available from our Sales Department (enquiries@biral.com). For a full list of the currently available country codes please refer to the Present Weather Sensor Country Code List, available from our Sales Department (enquiries@biral.com) or as a download from the SWS-200 product page of our website (www.biral.com).
Configuration	Reserved for customer specific configurations. Option <b>RC</b> : No customer specific configuration Option <b>SC</b> : Special customer specific configuration

# SWS-200

## Visibility & Present Weather Sensor Specifications



### Visibility & Present Weather Measurement

Measures	Visibility and present weather	
Output	Digital, analogue and switching relays	
Range (visibility) (Fixed, select at time of order)	Default 10m to 20km Select 10m to 10km, 10m to 20km, 10m to 32km, 10m to 50km or 10m to 75km	
Measurement Error	≤ 4.5% at 600m, ≤ 5.1% at 2km, ≤ 20% at 30km	≤ 5.0% at 1,500m, ≤ 12.5% at 15km, ≤ 20% at 30km
Measurement principle	Forward scatter meter with 39° to 51° angle	
Precipitation detection threshold	Rain: 0.015mm/hr (0.0006 in/hr)	Snow: 0.0015mm/hr (0.00006 in/hr)
Maximum rain rate	~ 500 mm/hr (20 in/hr)	
Rain intensity accuracy	≤ 15%	

### Outputs and Reports

Output rate (seconds)	10 to 300 (selectable)	
Serial outputs	RS232, RS422 and RS485	
Analogue outputs	0-10V (0-20mA or 4-20mA optional)	
Switching Relay (user programmable)	Relay 1 = Fault Relay 2 = Visibility (user selectable value) Relay 3 = Precipitation yes/no or snow yes/no or visibility (user selectable)	
Present Weather	WMO Table 4680 codes	

### Power Requirements

Sensor power	9-36 VDC (Optional mains adaptor)
Hood heating power	24 V AC or DC
Basic sensor	3.5 W
Window heaters	2.5 W
Hood heaters	36 W

### Additional Features

Hood heaters	Optional
Window contamination monitoring	Fitted as standard to the transmitter window. Optional on receivers
Window heaters	Fitted as standard

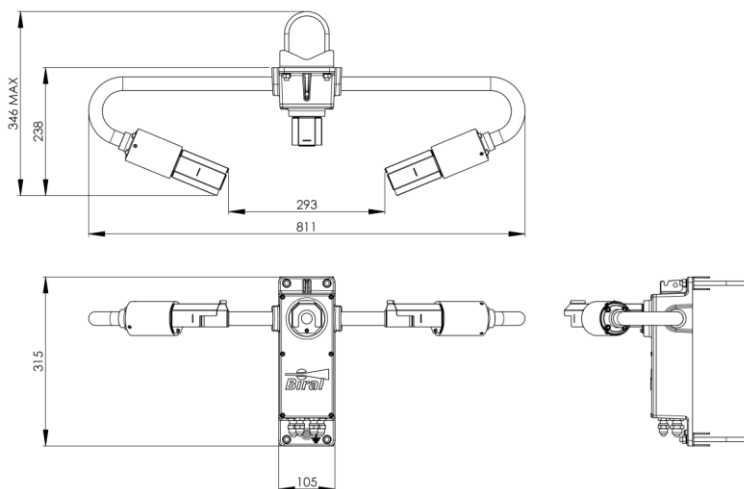

Dimensions in mm

### Environmental

Operating temperature	-40°C to +60°C
Operating humidity	0 – 100% RH
Protection rating	IP66/IP67

### Certification & Compliance

CE Certified
EMC compliance with EN61326-1997, 1998, 2001
RoHS and WEEE compliant

### Physical

Material	Powder paint coated aluminium
Weight (incl. mounting kit)	4.5 kg
Length	0.81 m
Warranty	3 Years
Lifetime	>10 Years

### Maintenance

Self-test capability	As standard
User confidence check	6 months recommended
Window cleaning	Automatic compensation and warnings
Field calibration	With optional calibration kit

### Included with Sensor

The SWS sensor is delivered in sturdy recyclable foam filled packaging with:
- Pole mounting kit (2 x U-bolt and saddles)
- User manual and calibration certificates

### Accessories – Optional

Part No.	Description
00.SWS.CABLE-D	SWS Series Data Cable per metre
00.SWS.CABLE-P	SWS Series Power Cable per metre
SWS.CAL	SWS Series Calibration Kit
SWS.CASE	SWS Series Transit Case
SWS.SK.200	SWS 200 Spares Kit
SWS.WTY200	1 Year extended warranty
PW.CODE	User defined precipitation definitions. Per definition set
PW.MAINS	Mains Power Adaptor

Specifications are subject to review and change without notice. E&OE.